

Problem T7

Consider the following common source JFET amplifier circuit. Notice that it includes an additional bias resistor, R_1 , compared to the usual self-biasing circuit.

Assume that transistor achieves the desired transconductance with $V_{GS} = -0.5$ V. However, due to design constraints, the voltage drop across R_S must be 7.8 V. In this case, the self-biasing approach for V_{GS} cannot work.

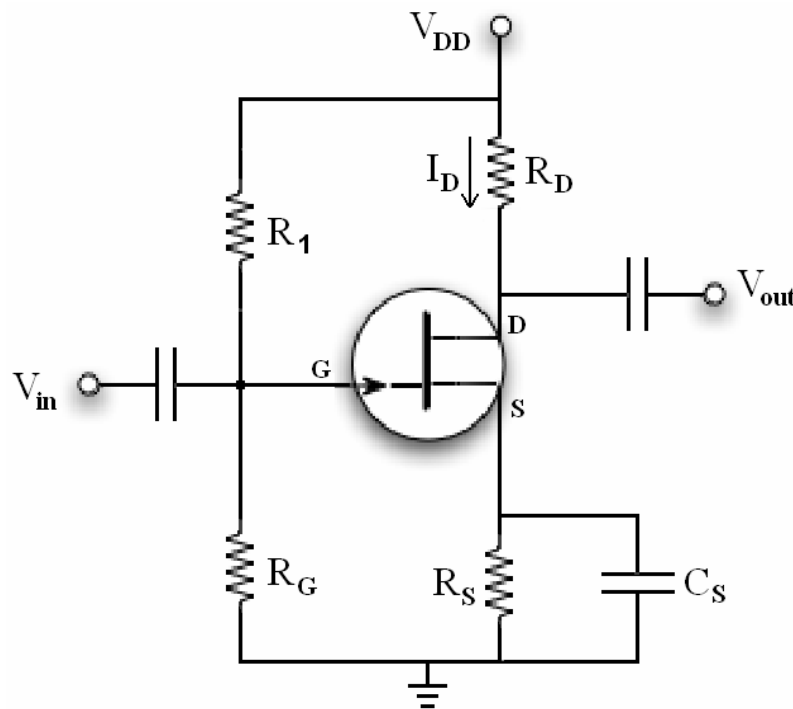

- If $V_{DD} = 10.0$ V and $R_G = 1$ M Ω , what value of R_1 is required to bring V_{GS} to -0.5 V?
- Is the input impedance compromised (i.e. smaller) as a result of the additional bias resistor?
- What is the input impedance with and without the inclusion of R_1 ?