

Phy 440 Lab 9: Bipolar Transistors II

Transistor circuits can be used to obtain stable sources of constant voltage. The following sections trace the development of a simple voltage source using a single transistor.

The pass transistor

Build the emitter follower circuit below, called the “pass-transistor” circuit.

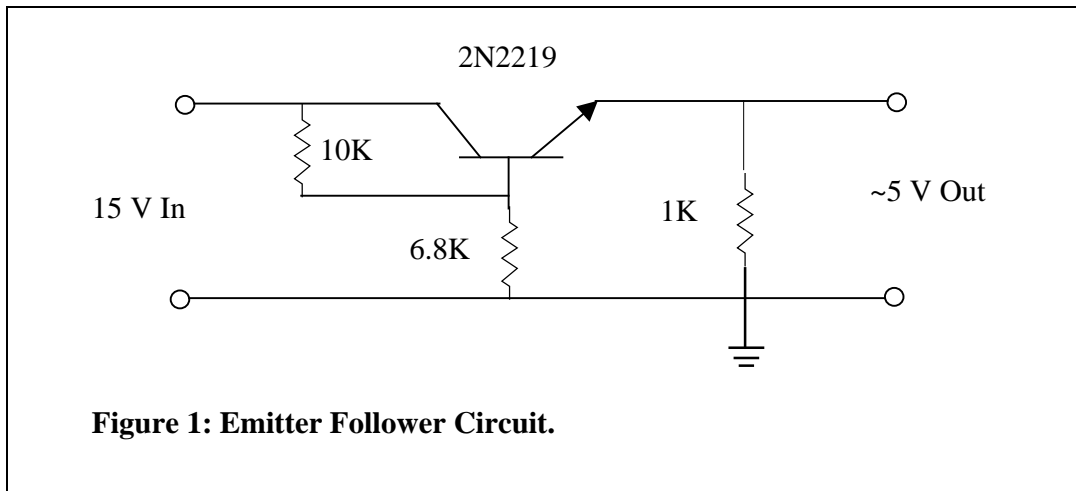
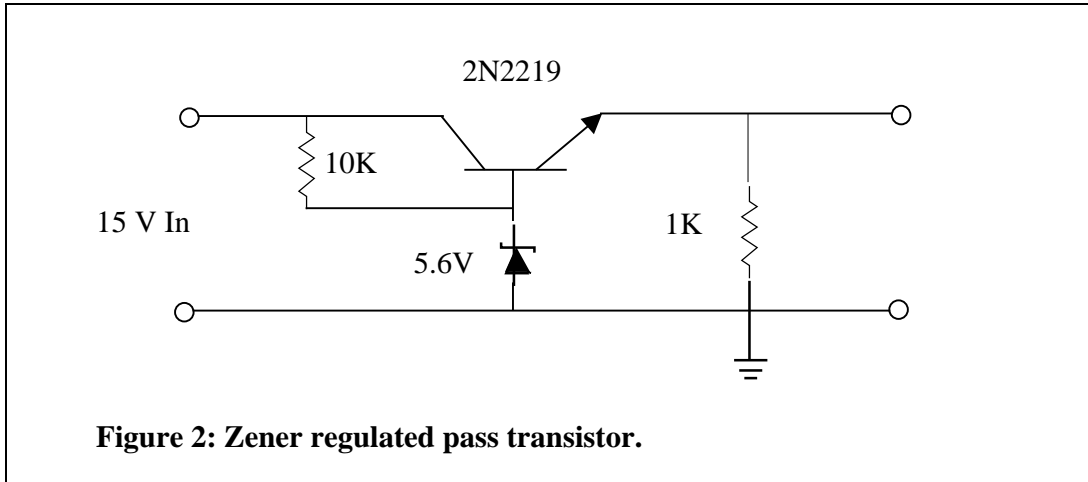

Figure 1: Emitter Follower Circuit.

- (a) Calculate the output impedance. (Hint: It is approximately equal to the output impedance of the circuit that supplies the base current divided by β .)
 - (b) Measure the output impedance by finding the change in voltage when the circuit is loaded by 150 ohms.
 - (c) Reduce the input voltage from 15 volts to 10 volts, a 33% change. What is the percentage change in the output voltage?
1. *The Zener-regulated pass transistor*
 Replace the 6.8K resistor by a reversed-biased 5.6 volt Zener diode.



- Measure the output impedance as above.
- Find the change in output voltage when the input voltage changes from 15 to 10 volts.
- Calculate the current in the 10K resistor and zener diode. Is this enough current to drive the zener beyond the knee in the V-I characteristic? Can you improve the circuit by reducing the 10K resistor?

Construction of a power supply

On a piece of perforated board solder together the following circuit:

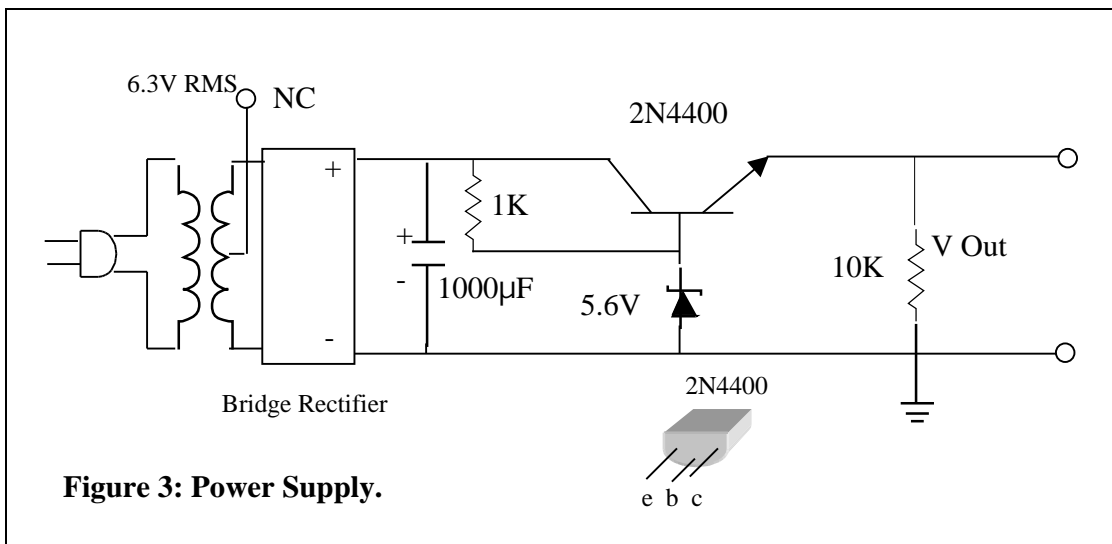

The output should be about 5 volts.

“NC” means no connections to the center tap on the transformer.

Plot I vs. V for this supply by loading it.

Note: The zener-regulated pass transistor developed in this lab is an acceptable source of stable voltage to be used when circumstances are not demanding. Transistorized power supplies with two or three transistors in a fast negative feedback circuit are used when the load conditions are variable. These can give output impedances less than an ohm and high stability against temperature variation. Figure 4 below is a common example of a negative-feedback circuit. Transistor Q_1 is normally conducting because of the bias current through R_1 . When the output voltage reaches 10 volts, Q_2 begins to conduct, shunting current away from the base of Q_1 and preventing further rise of the output voltage.

