

## PHY 440 Lab3: Light Emitting Diodes and Digital Circuits I

### The Light Emitting Diode:

The light emitting diode (LED) is used as a probe in the digital experiments below. We begin by studying the properties of the LED.

The LED is first of all a diode. It passes current in one direction but not in the other.

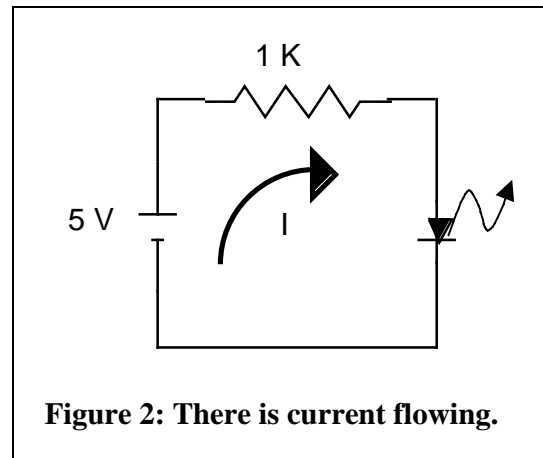
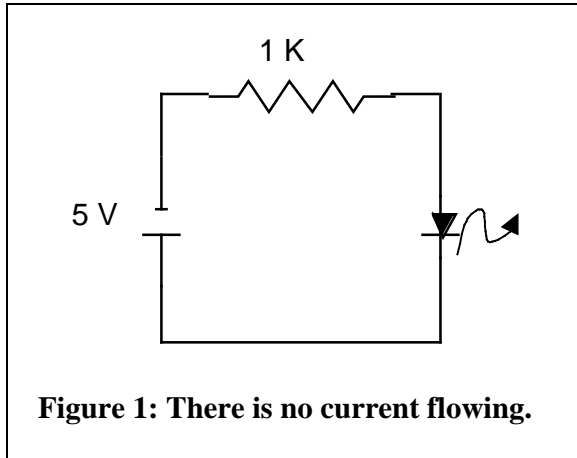

In Figure 1 the diode is biased in the backward direction or “reverse biased” and there is no current flowing through it whereas in Figure 2 the diode is “forward biased” and there is current flowing.

The LED gives off light when it is *forward* biased. The symbol for the LED is:



or

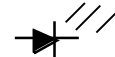

### Experiment 1:

Build the two circuits shown above and observe that the LED glows in only one orientation. Use a variable voltage power supply and watch the LED intensity increase with increasing supply voltage.

### Experiment 2:

Set up the forward-biased circuit. Use the oscilloscope to measure the voltage across the LED as the power supply voltage is increased. You should find that when the LED is glowing normally the voltage is saturated at about 2 volts, as sketched below in Figure 4.

### Experiment 3:

Set up the forward-biased circuit in Figure 3. It is the same circuit as far as the LED is concerned, but it enables you to measure the voltage across the resistor without worrying

about ground connections. Measure the current in the circuit by using an oscilloscope to measure the voltage across the 1 K resistor. (With  $R = 1\text{ K}$ , the current in milliamperes (mA) is directly equal to the voltage in volts). Observe the increasing brightness as a function of current as you increase the supply voltage. You should find that a current between 5 and 10 mA gives a normal glow.

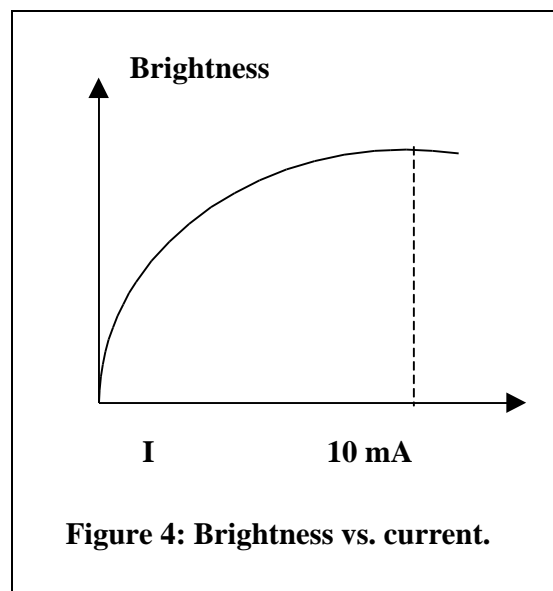
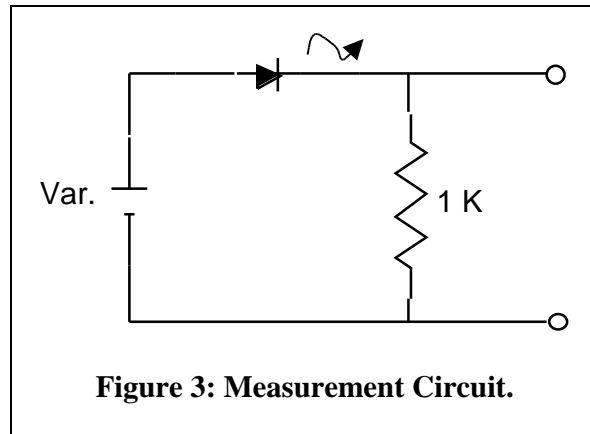

**Experiment 4:**

Calculate the current in the circuit in Figure 5 below.

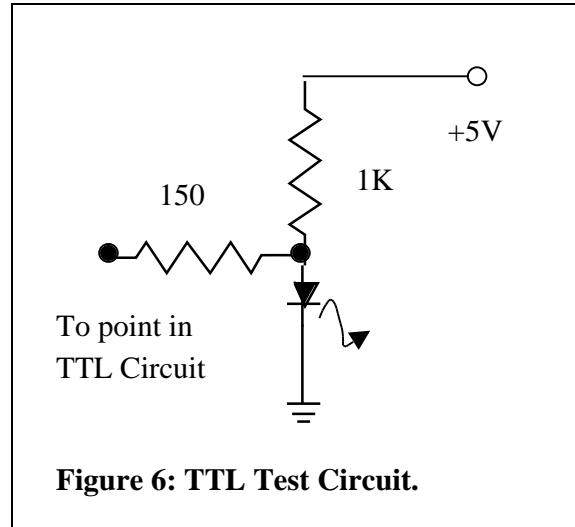
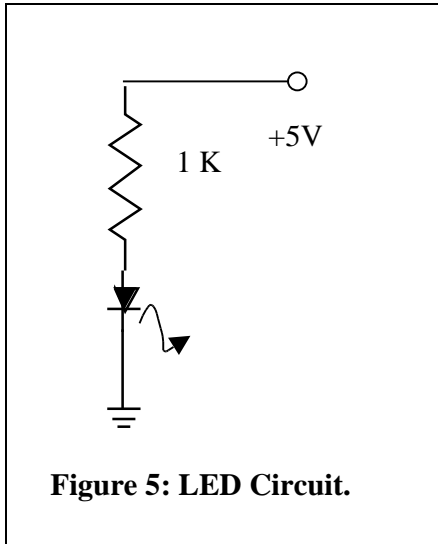

The answer to the question on Figure 5 is about 3 mA. We use the circuit shown in Figure 6 to determine whether a point in a TTL circuit is logically high or logically low. If it is high then this point will not cause much voltage drop on the 1K resistor and the LED will glow. If the point is low then it will sink current, causing a voltage drop on the 1K resistor, and the LED will not glow.

### **7400 Quad Two-input NAND Gate**

Before doing this lab you should review the truth tables for AND, NAND, OR and NOR gates, on page 238 of DH.

We consider the TTL (transistor-transistor logic) device called the 7400. It is part of the TTL family of digital logic devices whose names all begin with 74. All members of this family operate from a power supply of + 5V. The members are all compatible in that outputs from one will serve as inputs for another.

Most members of the family come in 14-pin DIPs (dual inline packages). Pin 14 is supposed to be connected to +5V and pin 7 is supposed to be connected to ground. These connections are so standard that we don't even bother to draw them in the circuits below.

The pin connections for the 7400 are shown below. Pin 1 is marked by a dimple on the case. Looking at the chip from the top, the pins are then numbered in a counterclockwise direction.

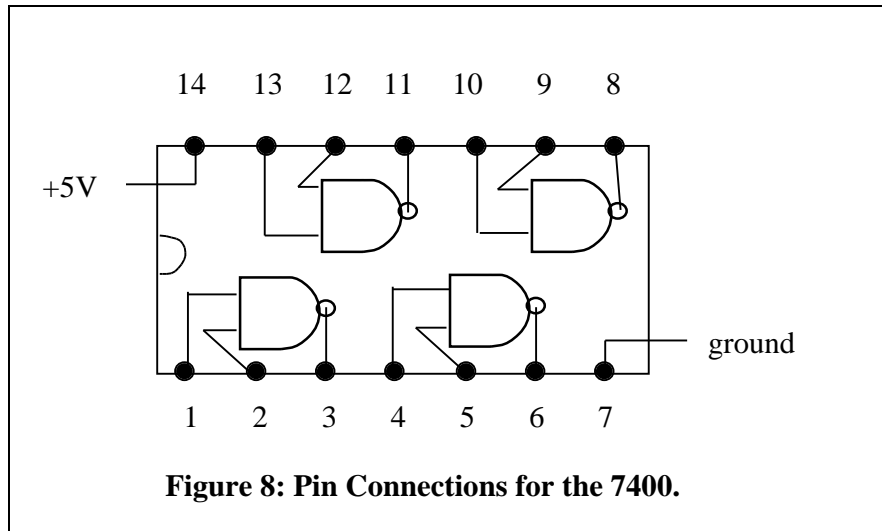

In Figure 9 below is shown a circuit that illustrates the basic principle of the two-input NAND gate. Note the LED indicator on the output.

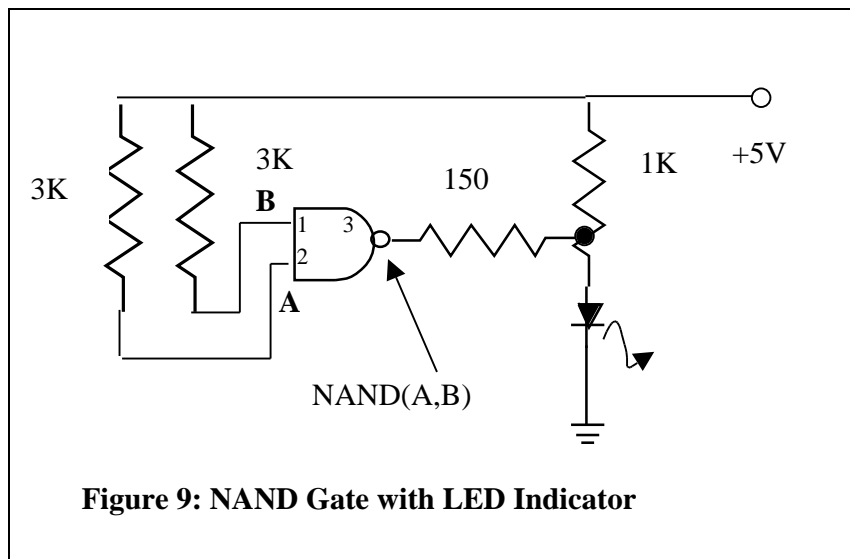

The 3K resistors pull the two inputs to a high state. According to the NAND truth table this is the only input configuration where the output is low and the LED is off. Points A and B may be grounded by means of a wire going to ground to bring them to a low state. In this way you can create a zero on the input.

A	B	NAND(A,B)
0	0	1
0	1	1
1	0	1
1	1	0

### Experiment 5:

Build the NAND circuit in Figure 9 and verify its operation for all choices of the inputs A and B.

### Inverter Turns NAND into AND

You can make a logical inverter (turns 1's into 0's and 0's into 1's) by connecting the two inputs of a NAND together. Begin by proving this fact logically by verifying the truth table.

A	B	AND(A,B)
0	0	0
0	1	0
1	0	0
1	1	1

### Experiment 6:

Convert your NAND circuit into an AND as shown below in Figure 10 and verify its proper operation.

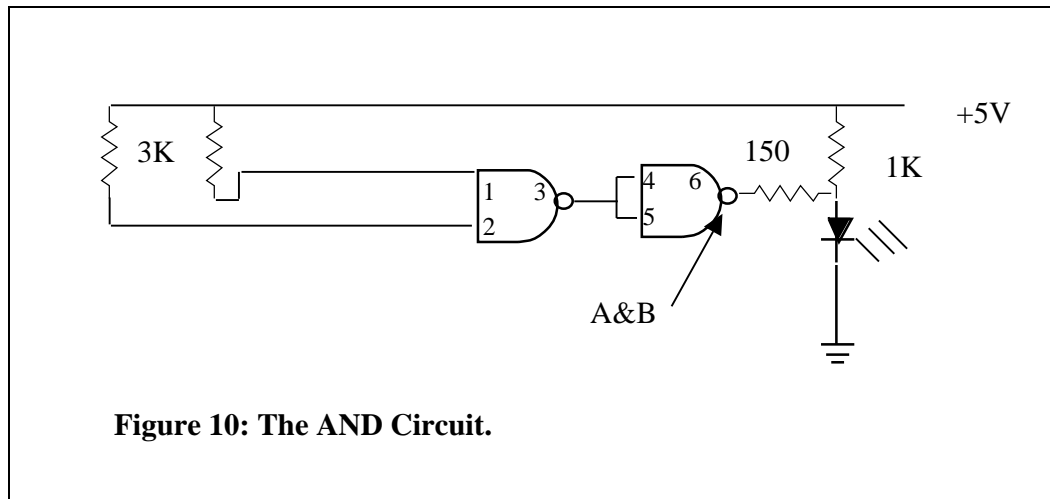

### Three NANDs can make an OR.

The circuit in Figure 11 inverts the two inputs to convert a NAND into an OR.

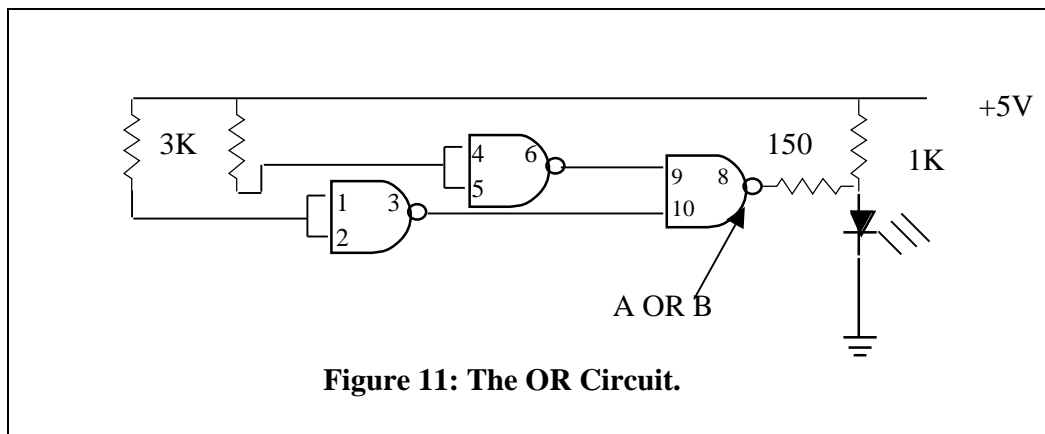

### Experiment 7:

Make the OR as shown and verify its proper operation according to the truth table.

#### Four NANDs can make a NOR

The circuit in Figure 12 below inverts the output to convert an OR into a NOR. A much simpler way of getting a NOR circuit is by using a 7402, which is, in fact, a quad two-input NOR gate.

A	B	OR(A,B)
0	0	0
1	0	1
0	1	1
1	1	1

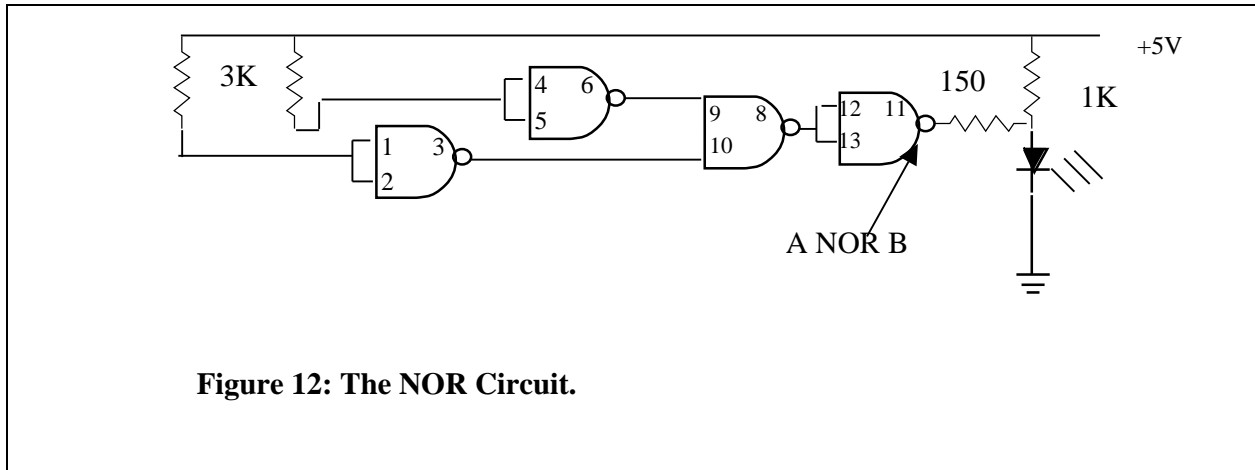

Figure 12: The NOR Circuit.

### Experiment 8:

Construct the NOR circuit in Figure 12 above and verify its operation relative to its truth table.

#### The Flip-flop

The circuit in Figure 13 below is a flip-flop made from two NAND gates. It has two stable states. By momentarily grounding input A you make output X go high and output Y go low. By momentarily grounding input B you make output Y go high and output X go low.

A	B	NOR(A,B)
0	0	1
0	1	0
1	0	0
1	1	0

### Experiment: 9

Explain why the flip-flop states are stable. That is, explain why the states remain unchanged after the momentary ground is removed.

Build the flip-flop and test it.

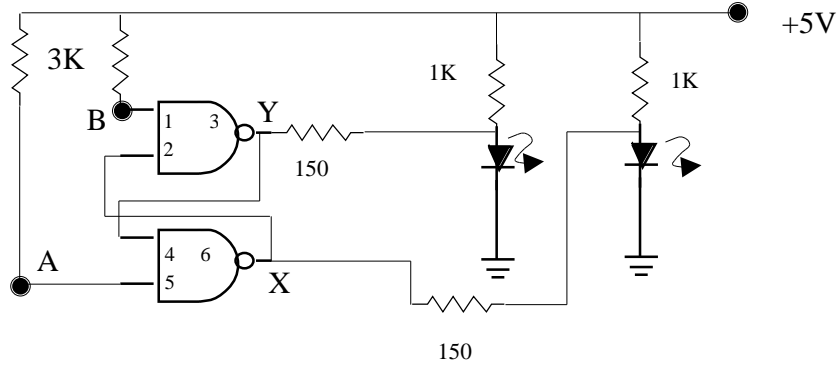

**Figure 13: The Flip-flop.**