

ADC, FFT, and Noise

Analog to digital conversion and the FFT

A LabView program, “Acquire&FFT_Nscans.vi”, is available on your pc which (1) captures a waveform and digitizes it using an analog-to-digital converter (ADC), (2) takes the fast Fourier transform (FFT) of a specified number samples of the waveform, and (3) displays the Fourier transform on the monitor. For the number of samples always use a number that is a power of 2, i.e. 2^n , because the FFT program works much more efficiently on such a sample.

1. Digitize low-frequency waves from the function generator, sine, triangle, and square. Observe the power spectra on the monitor and compare with expected power spectra. (Note: Because there is no anti-aliasing filter in front of the ADC, some components of the triangle and square are bound to be above the Nyquist frequency (component frequencies greater than half the sample rate) and lead to aliasing. But if the fundamental frequency is low, the components should be small.)
2. Digitize a sine wave with frequency f_0 greater than half the sample rate f_{SR} . Compare the frequency of the FFT peak with the calculated frequency of the alias, $f_{SR} - f_0$.

Noise

The best way to build a noise generator is to use a zener diode, reverse biased, and a high-gain amplifier. Figure 1 below shows how.

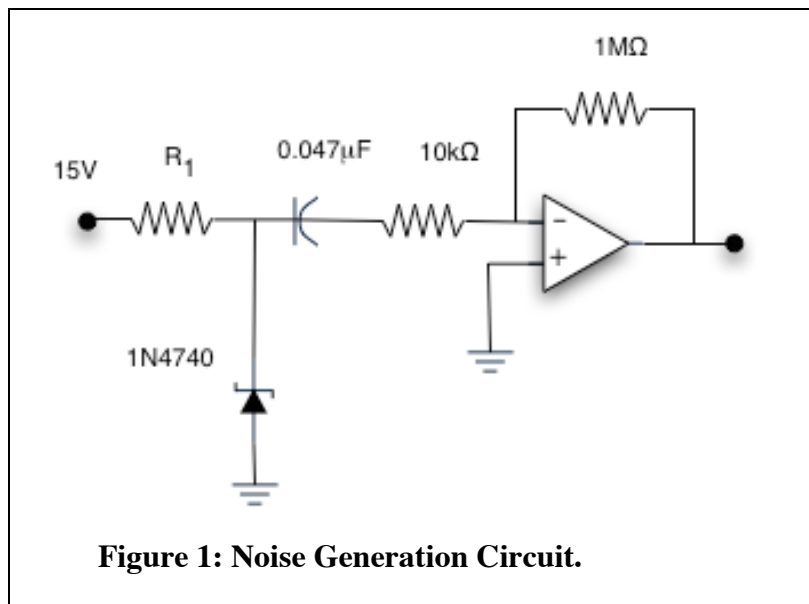

The strength and quality of the noise depends upon the diode and upon the current limiting resistor R_1 . As a rule, high-voltage zeners work best. Because the power supply is 15 volts, a zener with breakdown voltage between 10 and 13 volts is recommended.

Different zeners behave differently as noise sources. Even if they come from the same production lot they behave differently. The noise output from each zener is

maximized by a different value of R_1 . Some zeners don't make much noise for any value of R_1 . Some zeners make a lot of noise but only for a rather specific value of R_1 . Other zeners make a lot of noise for a wide range of values of R_1 . In the end, if you want to make a noise source, buy ten high-voltage zeners and select the best one.

For this lab you will receive a 10-volt zener, type 1N4740. The optimum value of R_1 is in the range 30 to 50 Ω k. Try a couple of resistors in this range selecting the one that gives the most noise.

A. Make the noise source using a TL084 quad op amp. Observe the noise on the oscilloscope. Can you use the oscilloscope to estimate a typical frequency of the noise? (The expected answer is NO.)

The Color of Noise

White noise has equal power per unit frequency. That is, the spectral density measured in watts per Hertz is the same for all frequencies. The zener diode noise source makes noise that is white over a very broad frequency range.

- (1) Show that noise cannot be absolutely white by showing that if the spectral density is constant over an infinite frequency range then the total power is infinite.
- (2) Examine your noise power spectrum using the LabView program supplied. Extend your measurements to the highest frequencies permitted by the data acquisition hardware. Your program will complain if you exceed the maximum data acquisition rate. Use a logarithmic scale for your plot.
- (3) Is your noise spectrum consistent with white noise? If not, at what frequency does it start to deviate from it?
- (4) Observe your noise spectrum at the highest frequencies carefully and try to characterize its dependence on the frequency.
- (5) Besides white noise, which has a flat frequency spectrum, there are other kinds of noise encountered in electronic systems. Shot noise has a Gaussian frequency dependence and flicker noise varies like $1/f$. Does your measured spectrum show the presence of either of these kinds of noise? Justify your conclusions.

Probability density function

Thermal noise is "Gaussian." That means that the distribution of instantaneous values is a normal (Gaussian) distribution. Implicit here is a thought experiment in which you make a lot of measurements of the instantaneous noise voltage and plot a histogram (PDF) showing the frequency with which each voltage value occurs. The histogram turns out to be a normal distribution, as shown in Fig. 2 below.

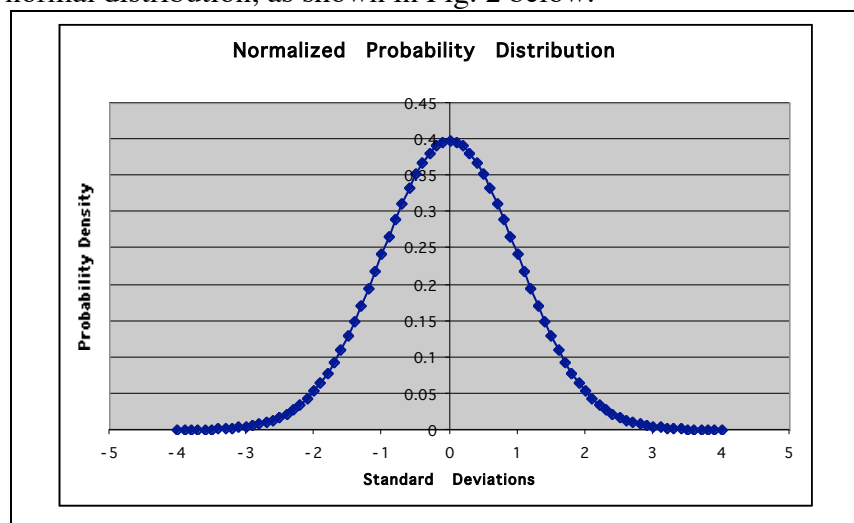

Other distributions of interest to us include a rectangular distribution where the probability is approximately constant between two limits and rapidly fall to zero outside of them and a bimodal distribution where the noise probability would have two peaks in its distribution.

You can get a rough idea of the PDF from looking at the noise on an oscilloscope.

Most 1N4740 diodes will show at least two of these PDF's, depending upon the values of R_1 .

Cumulative Probability Distribution

Another way to describe the PDF is by the cumulative distribution. The cumulative distribution is the answer to the question, "What is the probability that an instantaneous value of the voltage is less than voltage x . For Gaussian noise, the cumulative distribution is the Cumulative Normal, shown in Figure 3. This is the area under the normal distribution, integrating from minus infinity up to voltage x .

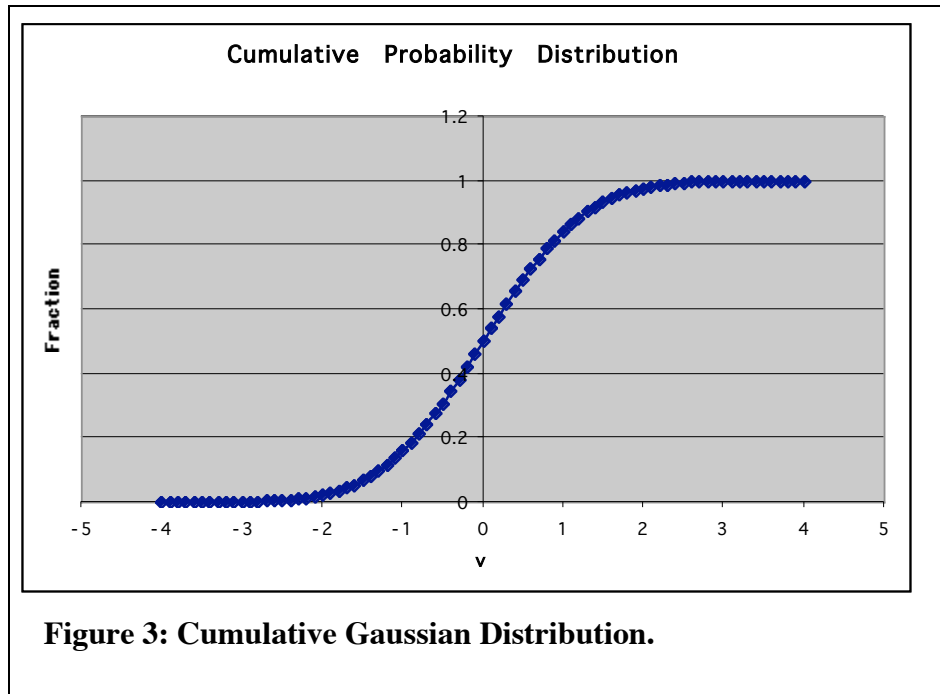

You can find the PDF using the circuit below.

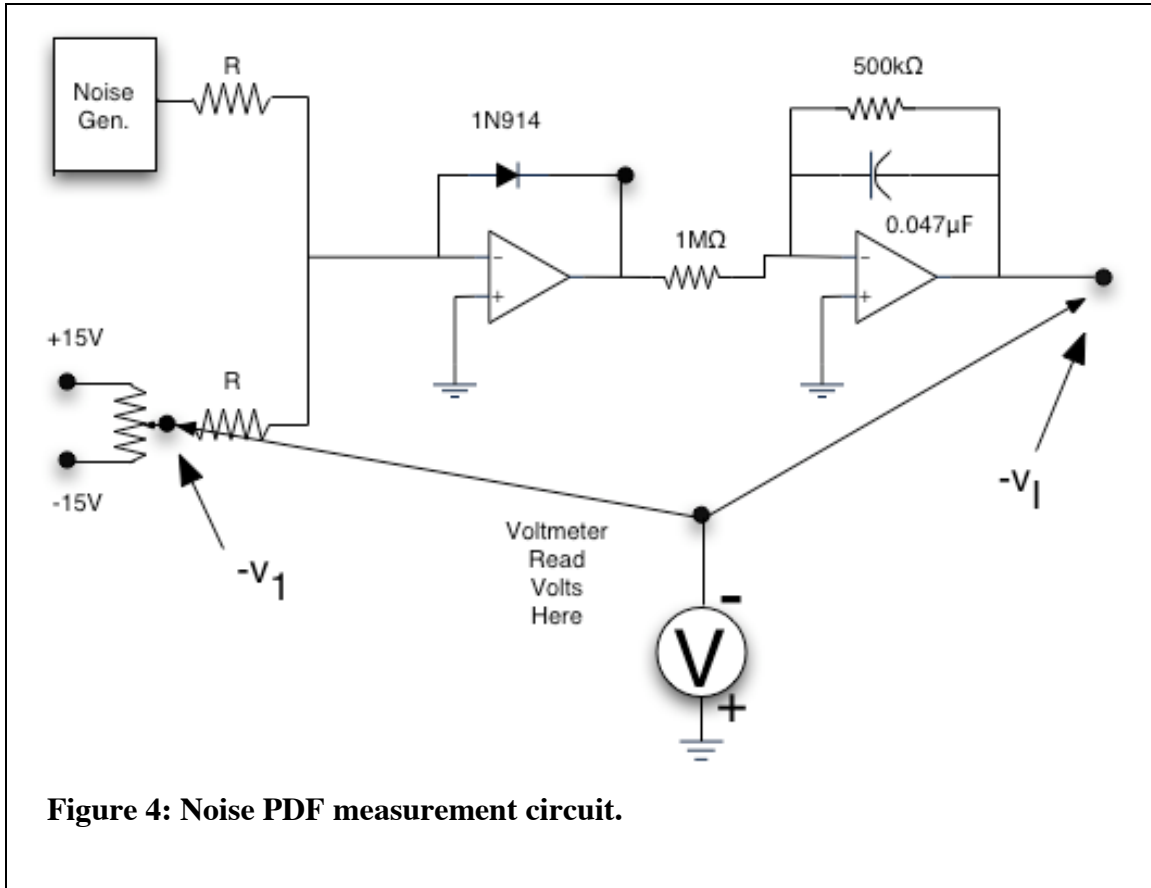

Figure 4: Noise PDF measurement circuit.

Analysis: When the sum of the noise voltage and the voltage called $-v_1$ is negative the output of the comparator goes to a high state. When the sum is positive the output of the comparator goes to zero (or something close to zero). The leaky integrator integrates the rectangular output from the comparator. It is an inverting integrator. Because the input pulses are positive the output will be negative. The absolute value of the integrator output voltage is proportional to the total time that the comparator output is high. It is therefore proportional to the time that

$$v_{noise} + (-v_1) < 0$$

namely, the time for which

$$v_{noise} < v_1$$

The latter equation defines the PDF.

1. Build the comparator/integrator circuit using the same TL084 as for the noise source.
2. Using the oscilloscope determine the points where the comparator is just barely firing (0% point) and just barely not firing (100% point). Integrator outputs are called $v_{I,\min}$ and $v_{I,\max}$ respectively.
3. Find lots of other points to find the PDF. As a function of v_1 , the probability is

$$P(v_1) = \frac{(v_1 - v_{I,\min})}{(v_{I,\max} - v_{I,\min})}$$