

## Op Amps II

### Op-amp relaxation oscillator

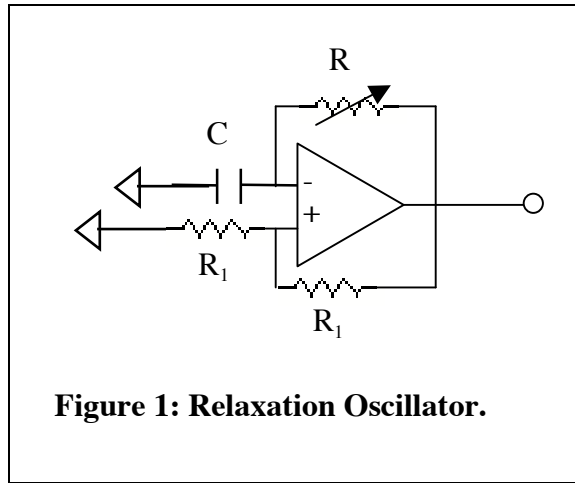

Build the relaxation oscillator shown in Figure 1 above. The output should be a square wave with a frequency about  $1/(2RC)$ . Resistor  $R_1$  can be any value between 1K and 1 M. Resistor R is one side of a potentiometer. Examine the voltages at (+) and (-) inputs and at the output and follow the action of the switching. It is useful to display  $v_+$  and  $v_-$  simultaneously on the same scale to illustrate that the switching occurs at the crossover of  $v_+$  and  $v_-$ . Note that the small triangular symbols indicate connections to ground.

### Low-pass resonant filter

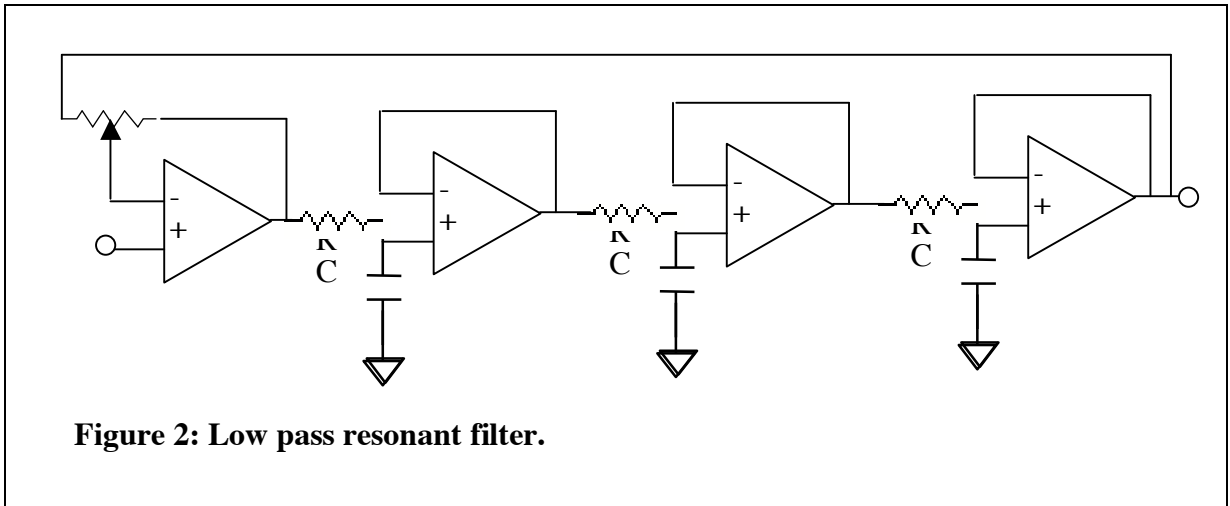

Show that the transfer function for the low pass resonant filter, shown in Figure 2, is given by:

$$H(\omega) = \frac{1}{1 - x + x(1 + j\omega\tau)^3}$$

where  $\tau = RC$  and  $x$  is the ratio of  $R_1$  to the total pot resistance  $R_1 + R_2$ . Here  $R_1$  is the part of the pot resistance between the output and the inverting input of the first opamp

and  $R_2$  is the part of the pot resistance between the inverting input and output of the first opamp.

[Hint: Begin by naming the output voltages of each op amp, from left to right, as  $v_1$  through  $v_4$ . Then use the infinite gain assumption to show that:

$$\frac{(v_4 - v_{in})}{R_1} = \frac{(v_{in} - v_1)}{R_2}$$

Next, use what you know about RC filters to find  $v_4$  in terms of  $v_1$ .]

When you understand the equation for the transfer function, build the circuit. It is convenient to use a TL084 with four op amps in a package.

Choose  $RC$  so that the resonant frequency is 2 to 5 kHz. Tune the pot until the circuit nearly oscillates. See how close you can get. Notice how oscillations grow and die exponentially. Find the resonant frequency by feeding in a sine signal from a function generator. (You may need to decrease the input voltage considerably to avoid saturating the filter near resonance.) Check the high frequency roll off. It should be proportional to  $1/\omega^3$ . Estimate the gain at resonance. Observe how the phase shift changes at resonance. Observe that the phase shift is not zero at the frequency where the gain is maximum. Make a Bode plot of the transfer function. (Spend your time wisely here by starting with a survey to find the frequencies where important features occur. Important features include resonance, high-frequency roll off and low-frequency constant region.)