

## Bessel, Henderson, & Struve—3 Oct

- You are a young astronomer in 1814. What problem do you want to study?
  - In 1814, Madison evacuated Washington, DC before the British attack.
  - Napoleonic Wars
- Measuring distances to stars enabled astronomers to study the physics of stars.



Friedrich Bessel  
1784-1846  
[hsci.cas.ou.edu/images/thumbnail/19thCentury/Bessel/](http://hsci.cas.ou.edu/images/thumbnail/19thCentury/Bessel/)



F G Wilhelm Struve  
1793-1864  
[www.obs.ee/obs/pildid.html](http://www.obs.ee/obs/pildid.html)

Thomas Henderson (1798-1844).

## Bessel, Henderson, & Struve Measure Distances of Nearest Stars

- Parallactic angle  
angle = baseline / distance
  - For the great distances of the stars, the angles are small and difficult to measure
- You are a young astronomer in 1825. What baseline should you choose?

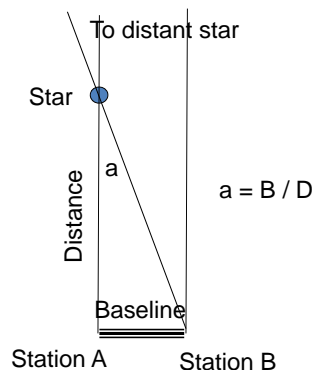

## Bessel, Henderson, & Struve Measure Distances of Nearest Stars

- Parallax angle  
angle = baseline / distance
  - For the great distances of the stars, the angles are small and difficult to measure
1. You are a young astronomer in 1825. What baseline should you choose?
    - A. London to South Africa
    - B. Paris to Cayenne
    - C. Earth and Earth 6 months later

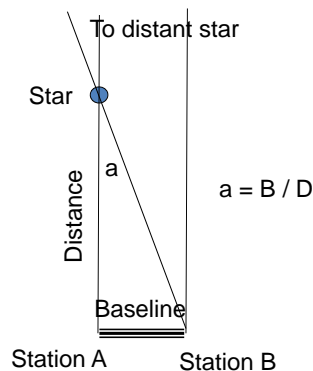

## Definition of arcsec and parsec

- Small angles are measured in arcsec
    - Arcsec=1/60 of an arcmin
    - Arcmin=1/60 °
  - Distances to stars are measured in parsec
    - For a star at 1 parsec, the parallax angle  $a$  is 1 arcsec for a baseline of 1 AU.
    - Nearest stars are about 1 parsec.
  - In general,  $a = B/D$
1. With a baseline of \_\_\_ and a distance in parsec, the  $a = 1/D$  is in \_\_\_\_\_.
    - A. 1AU; arcsec
    - B. 2AU; radians
    - C. 1AU; radians
    - D. 2AU; arcsec

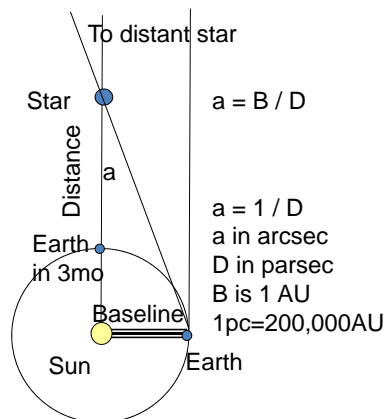

## Picking a star

2. You are a young astronomer in 1825. Measuring the distance to one star requires years of work. What type of star should you choose to likely get a close one? Bright/faint? Fast/slow? (A fast star is one that moves across the sky a few arc per year. Motion across the sky is called “proper motion.”)
- Bright or fast
  - Bright or slow
  - Faint or fast
  - Faint or slow

## First distances of stars 1837

- Thomas Henderson in South Africa
- Wilhelm Struve in Dorpat, now in Estonia
- Frederich Bessel in Königsberg, now in Russia

	Star	Char	Parallactic angle [arcsec]	Dist [pc]
Bessel	61 Cyg	Proper motion 5arcsec/yr	0.29	3.4
Struve	Vega	Bright	0.12	8.3
Henders on	$\alpha$ Cen	Bright	0.75	1.3

1. Which is the most distant star?
- 61 Cygni
  - Vega
  - $\alpha$  Centauri

## F G Wilhelm Struve

- Born in Altona (Denmark, now Germany)
- Educated at U Dorpat (Russia, now Estonia)
- Petition to Prince Lieven, Chancellor of University of Dorpat
  - “The opportunity to acquire this instrument, the possession of which would raise our observatory to one of the first in Europe, perhaps will never return.”
- The Great Refractor built by Fraunhofer arrived in 22 crates in 1824, and the city of Dorpat celebrated.
- Czar Alexander I sent diamond rings to Struve & Fraunhofer.



## Friedrich Bessel

- 61 Cyg was difficult because there is no nearby reference star.
- Fraunhofer built a telescope with a split lens to show two separate images.
  - By moving the two lens pieces, Bessel could offset the two images and bring 61 Cyg close to reference star.

Fraunhofer's heliometer with split lens

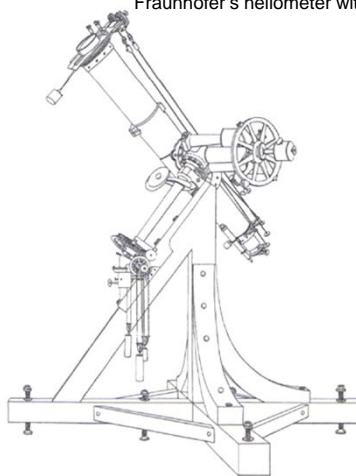

Lens pieces moved slightly



Lens pieces moved to align 61 Cyg & ref.

[pluslucis.univie.ac.at/FBA/FBA99/Neho/3\\_1\\_1\\_.htm](http://pluslucis.univie.ac.at/FBA/FBA99/Neho/3_1_1_.htm)

## Questions

- The parallactic angle  $a$  changes over the year because
  - the distance to the star changes.
  - the length of the baseline changes.
  - both A and B are important.
- You want to measure the distance of a star at right ascension 0hr. When are two times of the year between which the change in the parallactic angle is the greatest?
  - March & June
  - March & Sept
  - June & Sept
  - June & Dec

