

Figure 1.1

The development of optics, showing many of the interactions. Notice that there was little development in the eighteenth century, mainly because of Newton's erroneous idea of light particles. The numbers in square brackets indicate the chapters where the topics are discussed.

Light: Rays or Waves?

Geometry Optics is used when objects \gg wavelength (λ) of light.

$\lim_{\lambda \rightarrow 0}$ {physical optics} = {geometrical optics}

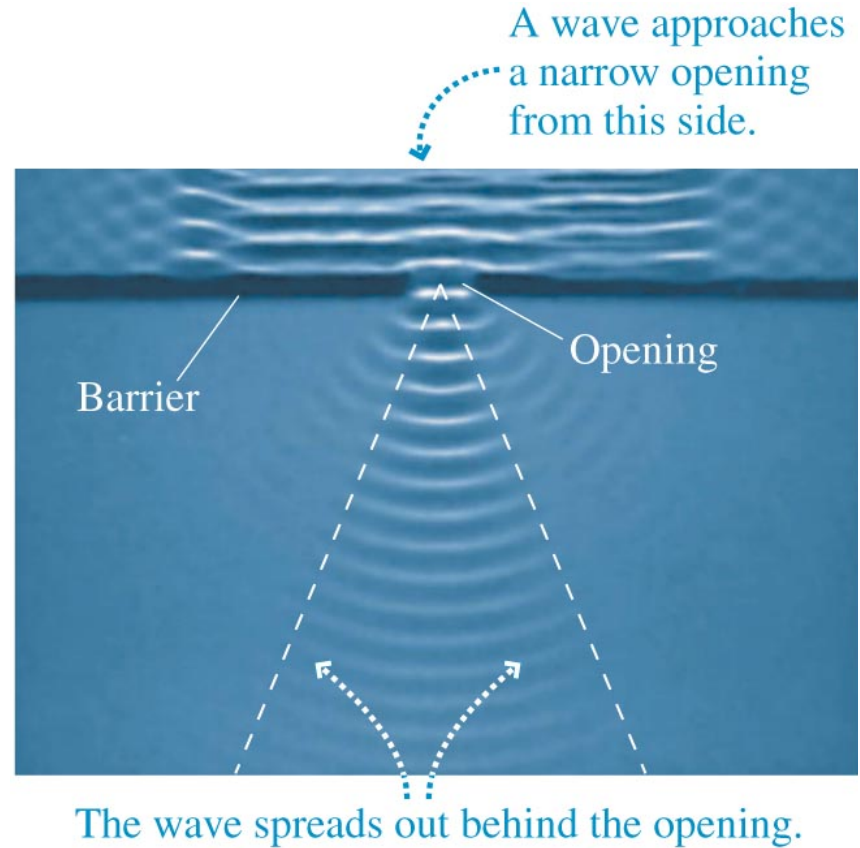
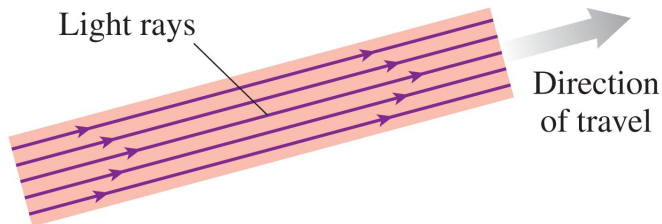
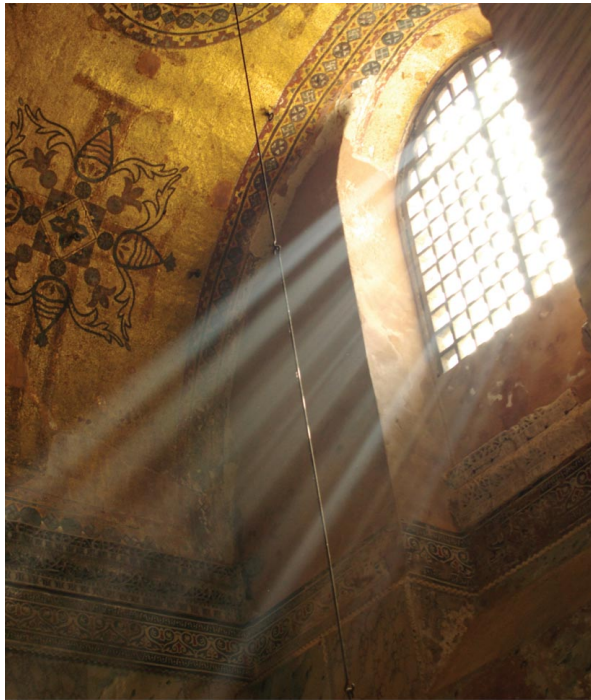

Wave Picture & Geometrical Optics

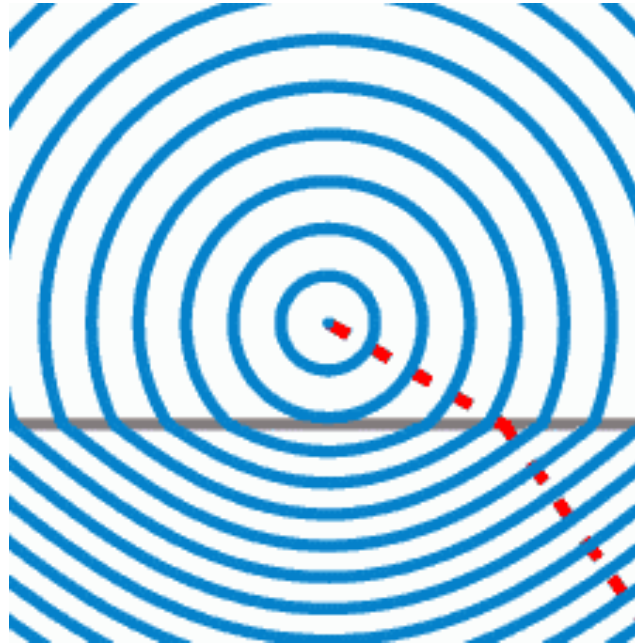

The domain of geometrical optics, as distinct from physical optics , is limited to situations where diffraction effects arising from the inherent wave nature of light are negligible.
-- that is, **rays are assumed to traverse straight lines.**

The Ray Model of Light

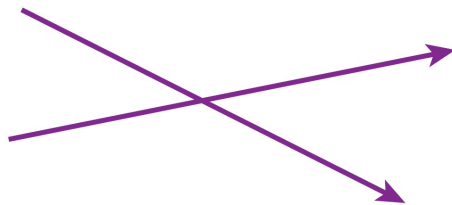

Light rays can cross.

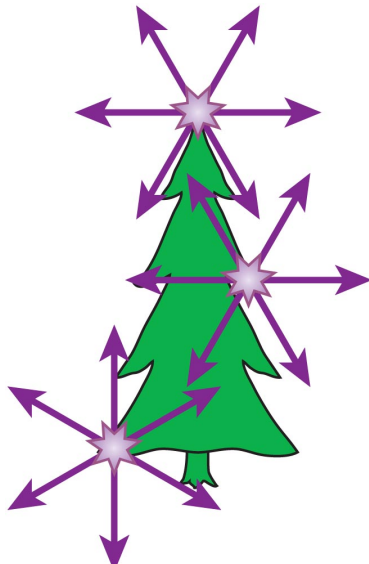

An object is a source of light rays.

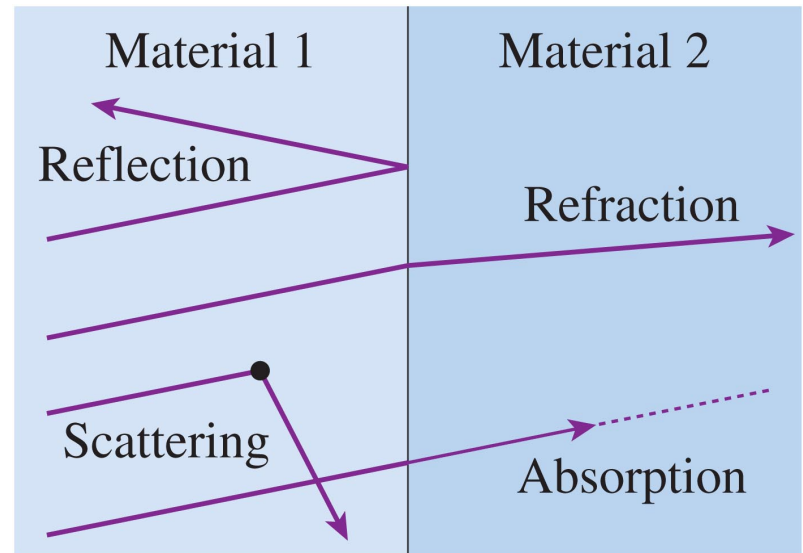

A light ray travels forever unless it interacts with matter.

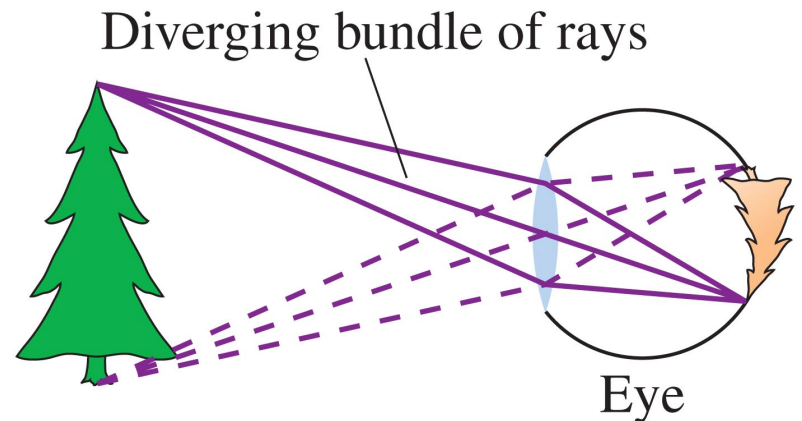

The eye sees by focusing a bundle of rays.

The Ray Model of Light

- Light travels through a transparent medium in straight lines, called light rays, at speed $v = c/n$, where n is the index of refraction of the medium.
- Light rays do not interact with each other.
- A light ray continues forever unless it has an interaction with matter that causes the ray to change direction or to be absorbed.
- At an interface between two media, light can be *reflected* or *refracted*. Within a medium, light can be *scattered* or *absorbed*.
- An *object* is a source of light rays. Rays originate from every point on the object, and each point sends rays in *all* directions. To simplify the picture, we use a *ray diagram* that shows only a few important rays.
- The eye “sees” an object when bundles of *diverging* rays from each point on the object enter the pupil and are focused to an *image* on the retina.

Index of refraction and ‘speed’ of light

The speed of light in vacuum is a physical constant.

$$c = 299\,792\,458 \text{ m/s (exact)} \sim 3 \times 10^8 \text{ m/s}$$

In a medium, light *generally* propagates more slowly.

- in air: $v = c/1.0003$ $n_{\text{air}} = 1.00$
- in water: $v = c/1.33$ $n_{\text{water}} = 1.33$
- in glass: $v = c/1.52$ $n_{\text{glass}} = 1.52$

In general:

$v = c/n$ is the “*phase velocity*”

wavelength/n

frequency is the same (in linear optics)

n also depends on the wavelength → **dispersion**.

Indices of refraction

The speed of light in vacuum is a physical constant.

$c = 299\,792\,458$ m/s (exact) $\sim 3 \times 10^8$ m/s

$$n = \frac{\text{speed of light in a vacuum}}{\text{speed of light in the material}} = \frac{c}{v}$$

A transparent material in which light travels slower, at speed $v = c/n$

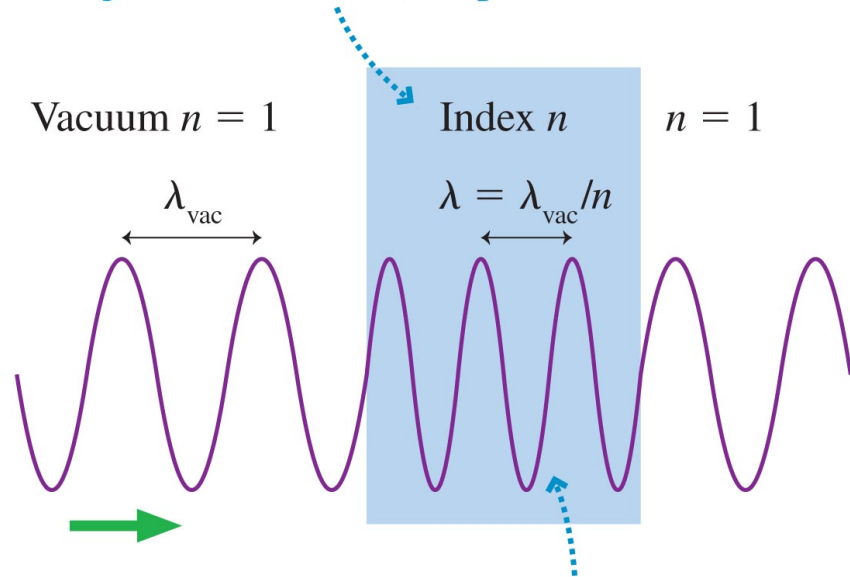

The wavelength inside the material decreases, but the frequency doesn't change.

Medium	n
Vacuum	1 exactly
Air (actual)	1.0003
Air (accepted)*	1.00
Water	1.33
Ethyl alcohol	1.36
Oil	1.46
Glass (typical)	1.50
Polystyrene plastic	1.59
Cubic zirconia	2.18
Diamond	2.42
Silicon (infrared)	3.50

*Use this value in problems.

Reflection and Transmission at an Interface

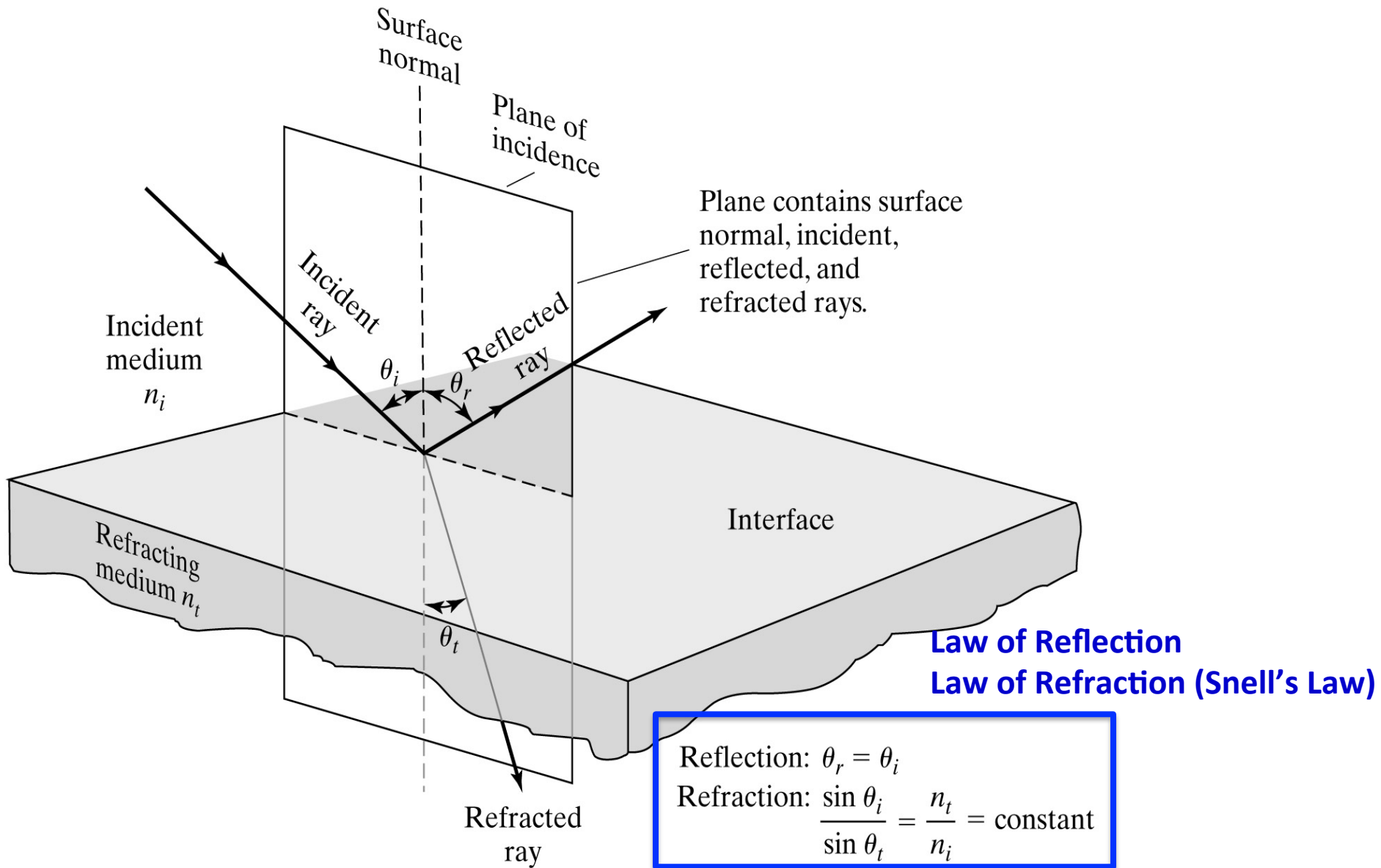

Law of Reflection

Both the incident and reflected rays lie in a plane that is perpendicular to the surface.

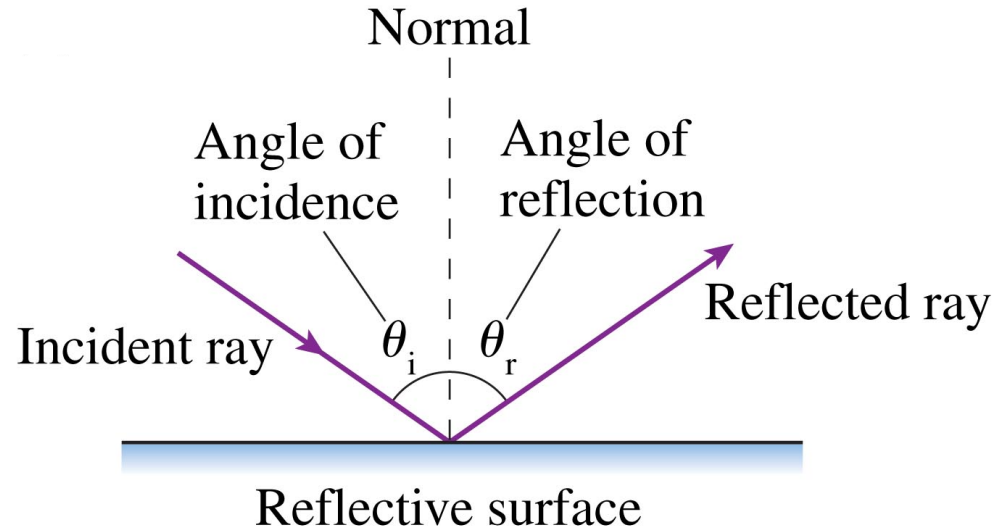
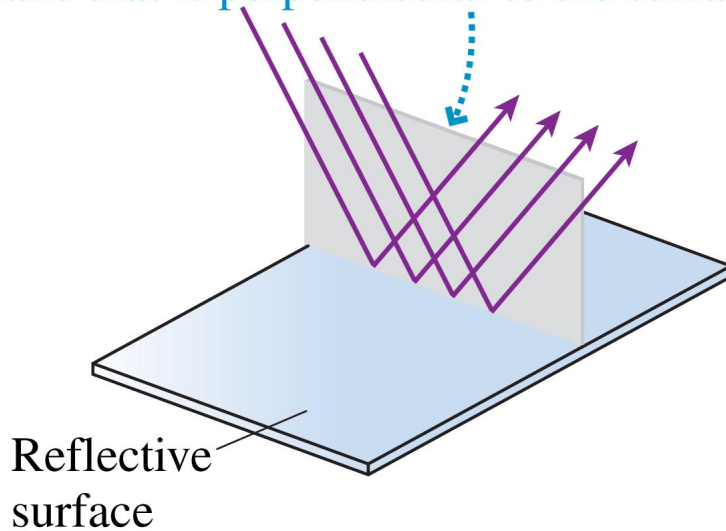

Optics calculations always use the angle measured from the normal not the angle between the ray and the surface.

1. The incident ray and the reflected ray are in the same plane normal to the surface, and
2. The angle of reflection equals the angle of incidence: $\theta_r = \theta_i$.

Reflection in Plane Mirrors

(a) Virtual Image

(b) The image position is independent of the position of the eye.

A right-handed object appears left-handed in its image.

(c) The mirror plane may be extended to determine the position of the image.

(d) Multiple images formed by sequential reflections.

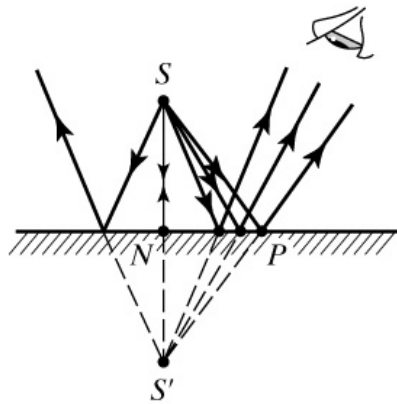

(a)

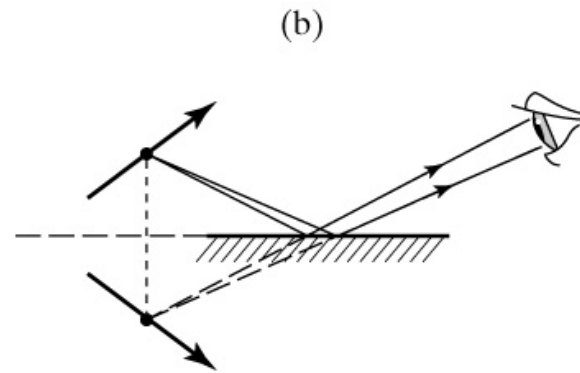

(b)

(c)

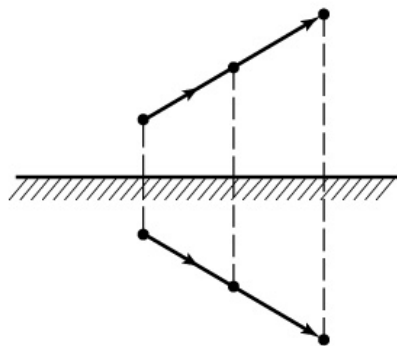

(b)

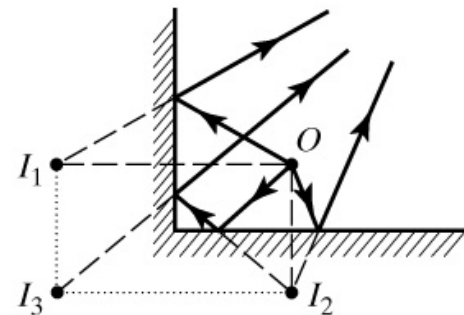

(d)

Specular Reflection vs Diffuse Reflection

Seeing an object by scattered light

Each ray obeys the law of reflection at that point, but the irregular surface causes the reflected rays to leave in many random directions.

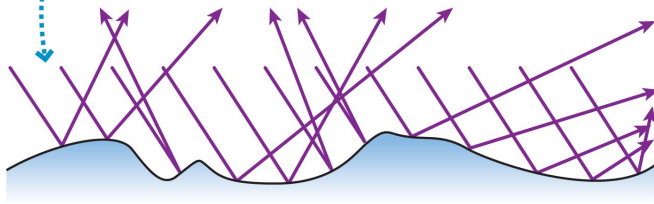

Magnified view of surface

An incident ray breaks into many weaker rays that scatter from this point in every direction.

Some scattered rays enter the eye, so the point is visible.

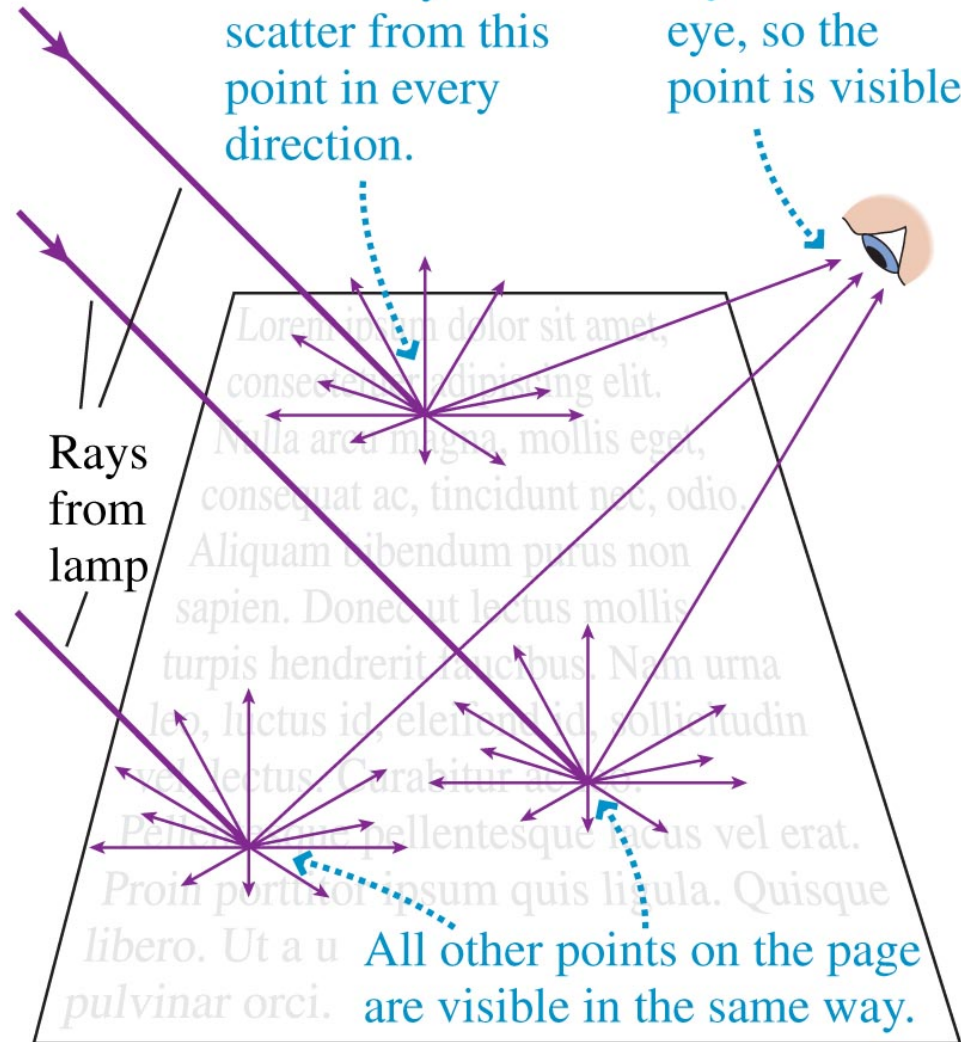

All other points on the page are visible in the same way.

Seeing Objects

Seeing a point or extended source

A point source

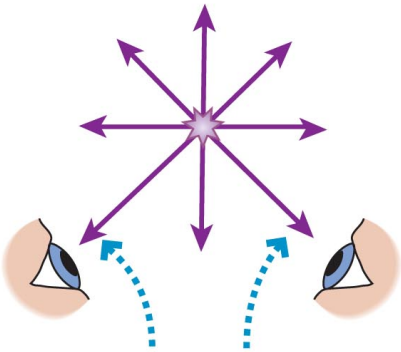

Everyone can see a point source.

An extended source

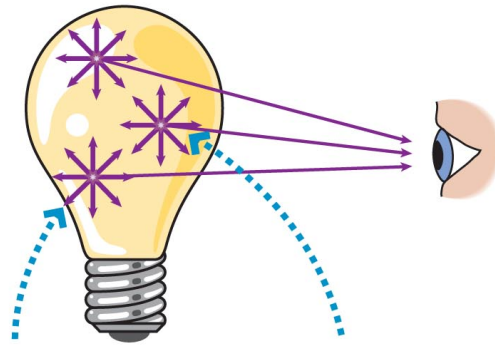

All points of an extended source are visible.

Seeing a ray source

Rays scatter in every direction from each smoke particle.

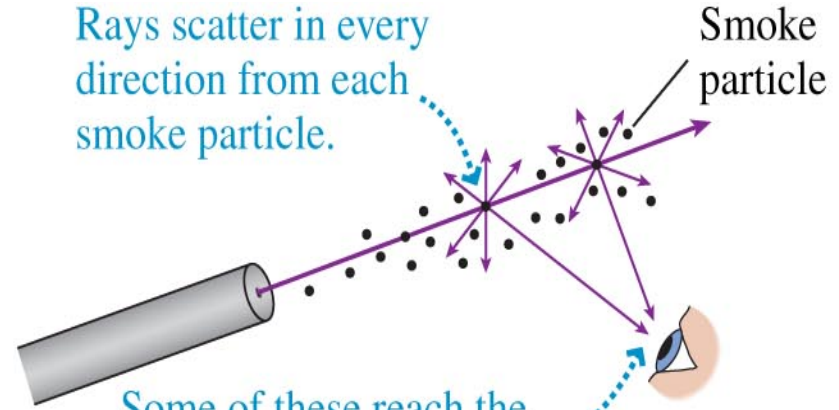

Some of these reach the eye, making the path of the laser beam visible.

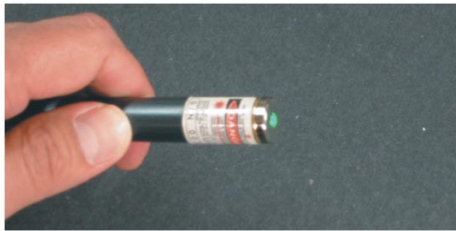

You can't see a laser beam crossing the room because no light ray enters your eye.

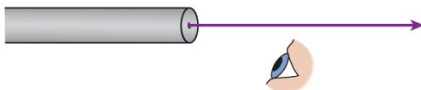

Huygens' Principle

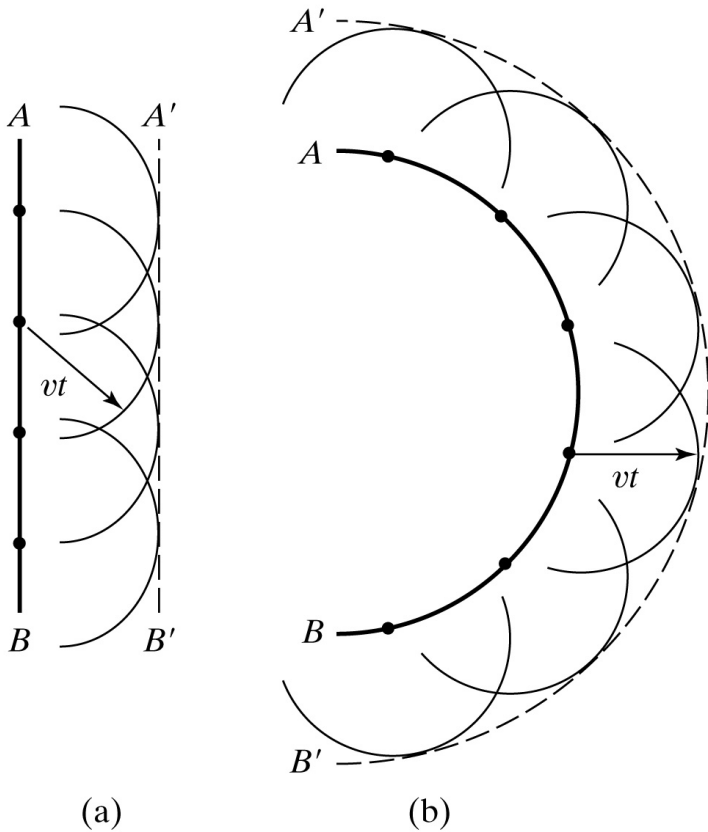

© 2007 Pearson Prentice Hall, Inc.

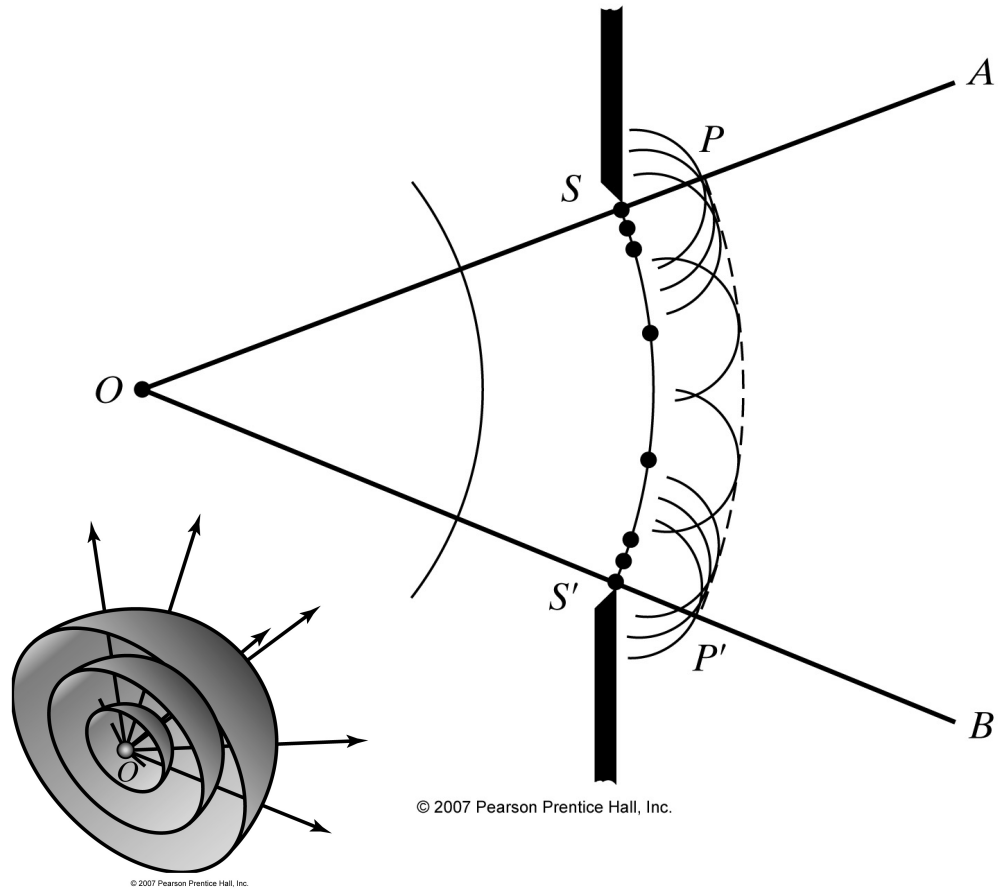

$$U(r_0) = \frac{U_0 e^{ikr_0}}{r_0} \quad U(P) = \frac{iU(r_0)}{\lambda} \int_S \frac{e^{iks}}{s} K(\chi) dS$$

See also http://en.wikipedia.org/wiki/HuygenFresnel_principle

Fermat's Principle & Principle of Reversibility

The ray of light travels the path of least time from A to B.

Any actual ray of light in an optical system, if reversed in direction, will retrace the same path backward.

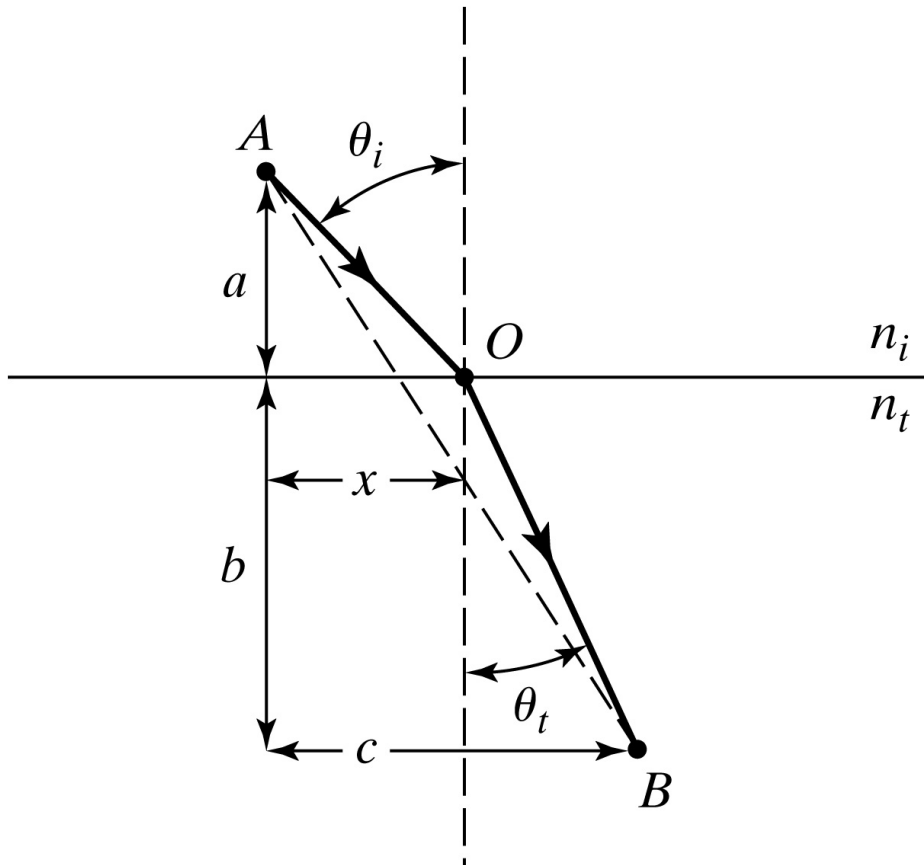

© 2007 Pearson Prentice Hall, Inc.

$$n_i \sin \theta_i = n_t \sin \theta_t$$

Snell's Law

$$n_1 \sin \theta_1 = n_2 \sin \theta_2 .$$

Frequency is the same.

$$\frac{\sin \theta_1}{\sin \theta_2} = \frac{v_1}{v_2} = \frac{n_2}{n_1}$$

$$\frac{\sin \theta_1}{\sin \theta_2} = \frac{v_1}{v_2} = \frac{\lambda_1}{\lambda_2}$$

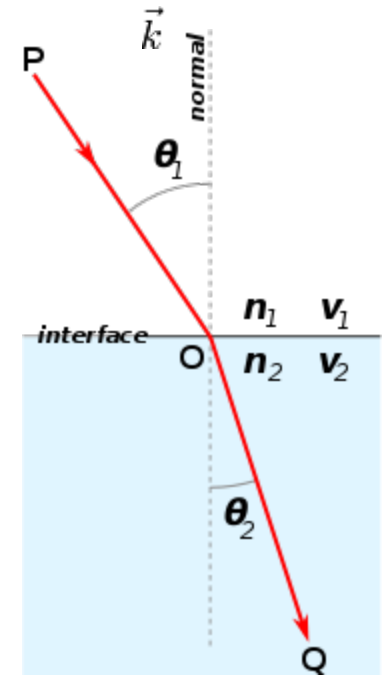

1. Huygens' principle
2. Fermat's principle
3. Interference of all possible paths of light wave from source to observer — it results in destructive interference everywhere except extrema of phase (where interference is constructive)—which become actual paths.
4. Application of the general **boundary conditions of Maxwell equations** for electromagnetic radiation. → amplitude of reflected and refractive waves [Chapter 23]
5. Conservation of momentum based on translation symmetry considerations

Wave Number, Wave Vector, and Momentum

Chapter 4, Pedrotti^3)

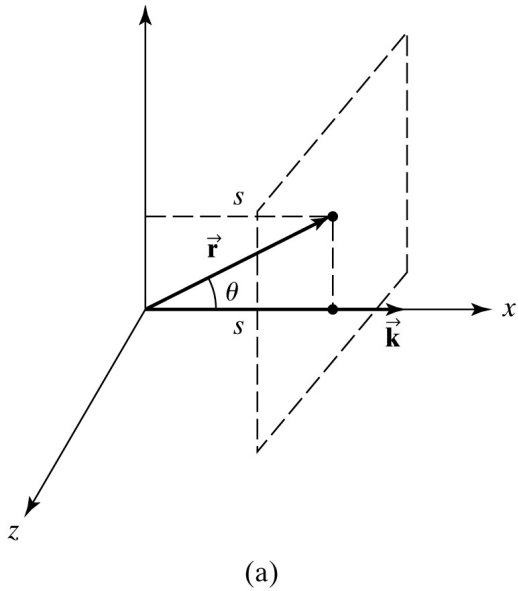

(a)

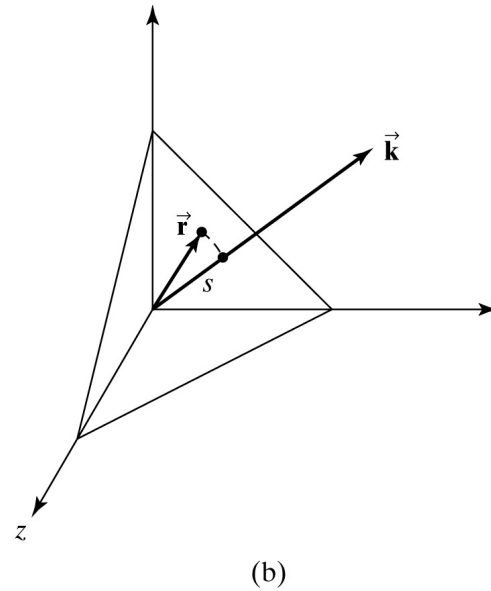

(b)

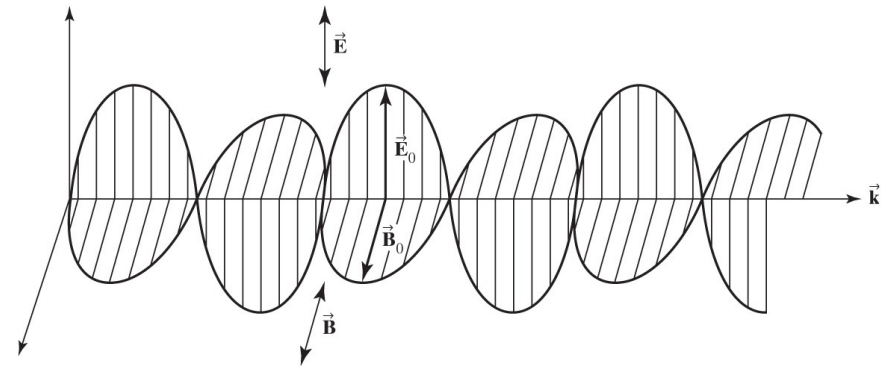

(a)

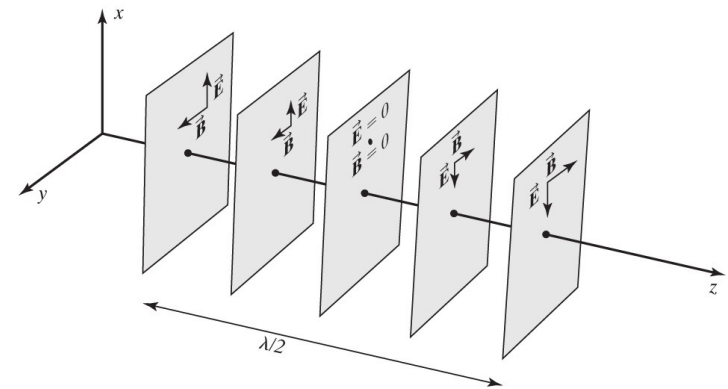

(b)

Derive Snell's Law by Translation Symmetry

A *homogeneous* surface can not change the transverse momentum.
The propagation vector is proportional to the photon's momentum.

$$E = pc$$

$$p = \hbar k$$

The transverse wave number must remain the same.

$$\vec{k}_1 \cdot \hat{x} = \vec{k}' \cdot \hat{x} = \vec{k}_2 \cdot \hat{x}$$

$$k_1 \sin \theta_1 = k' \sin \theta' = k_2 \sin \theta_2 \quad \hat{x}$$

$$k_1 = k' = \frac{2\pi}{\lambda_1} = \frac{2\pi}{\lambda_0 / n_1} = \frac{2\pi}{\lambda_0} n_1 = k_0 n_1$$

$$k_2 = \frac{2\pi}{\lambda_2} = \frac{2\pi}{\lambda_0} n_2$$

$$k_0 = \frac{2\pi}{\lambda_0} = \frac{\omega}{c}$$

$$n_1 k_0 \sin \theta_1 = n_2 k_0 \sin \theta_2$$

$$n_1 \sin \theta_1 = n_2 \sin \theta_2$$

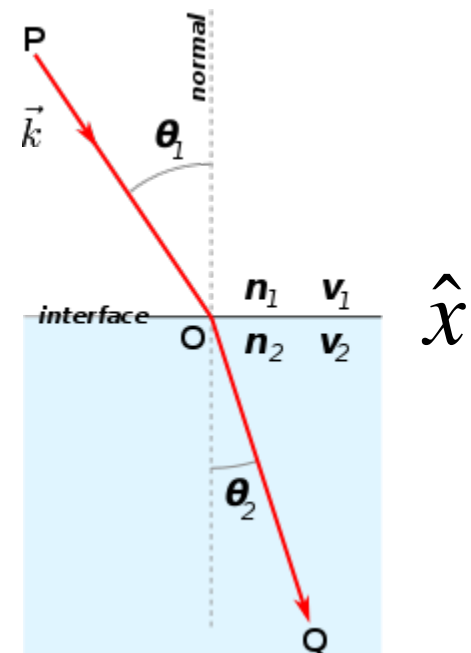

Refraction through Plane Surfaces

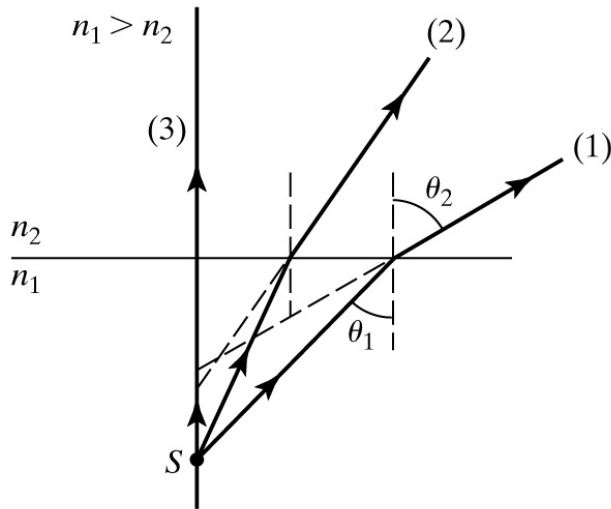

(a)

$n_1 > n_2$: The refracted rays bend away from the normal.

$n_1 < n_2$: The refracted rays bend toward the normal

A source point S below an interface emerge into an upper medium of lower refractive index.

➔ No unique image point is determined. These rays have no common intersection of virtual image point below the surface.

Small angle approximation, i.e. consider only *Paraxial Rays (making small angles with the optical axis)*

$$\sin \theta \cong \tan \theta \cong \theta \quad (\text{in radians})$$

Snell's law can be approximated by

$$n_1 \tan \theta_1 \cong n_2 \tan \theta_2$$

$$n_1 \left(\frac{x}{s} \right) = n_2 \left(\frac{x}{s'} \right)$$

s' : the image distance

s : the depth of the object

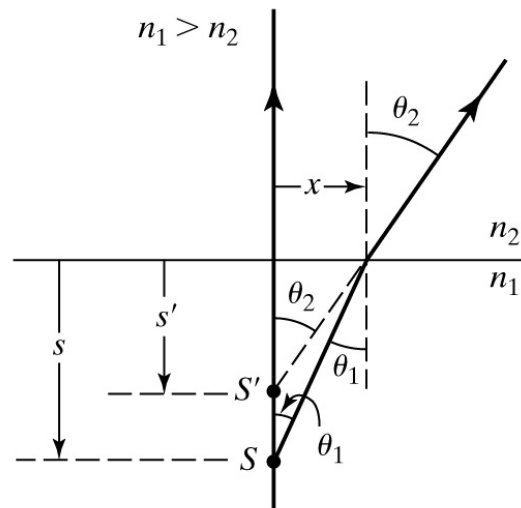

(b)

$$s' = \left(\frac{n_2}{n_1} \right) s \quad \text{for a small viewing angle } \theta_2; \text{ vary with the angle of viewing}$$

The fish problem ...

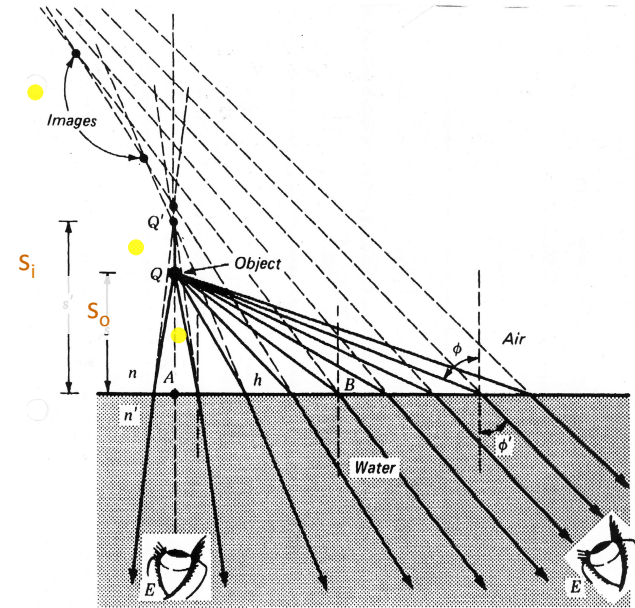
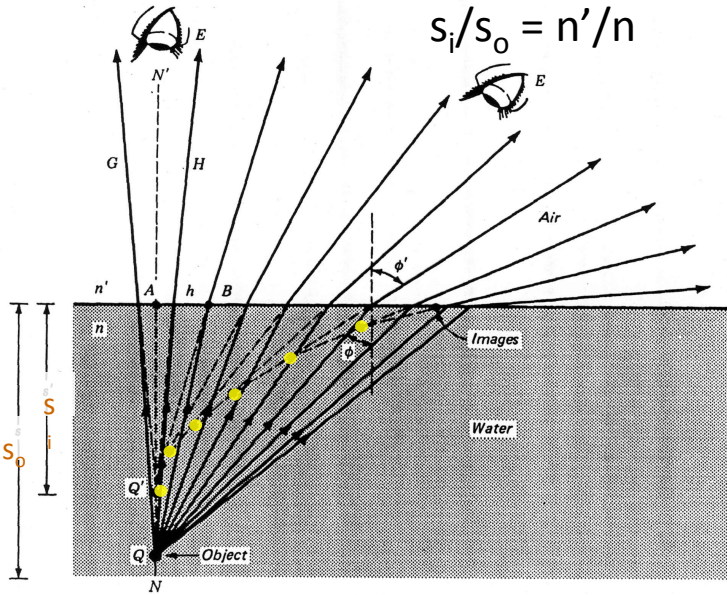

Displacement by a glass plate

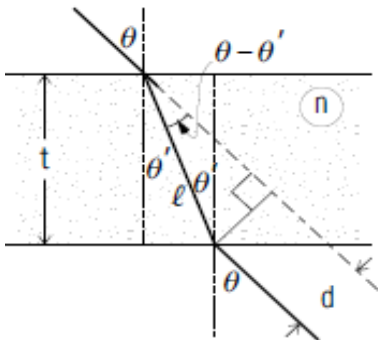

$$d = \frac{t \sin(\theta - \theta')}{\cos(\theta')}$$

Plane parallel plate placed in between a lens and its focus:

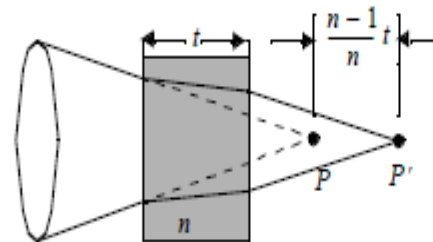

A simple calculation based on the paraxial approximation shows that the focus is displaced by amount $\frac{n-1}{n}t$. However, at steeper incidence angles, the focal shift becomes a function of the incidence angle, which leads to spherical aberration.

Total Internal Reflection

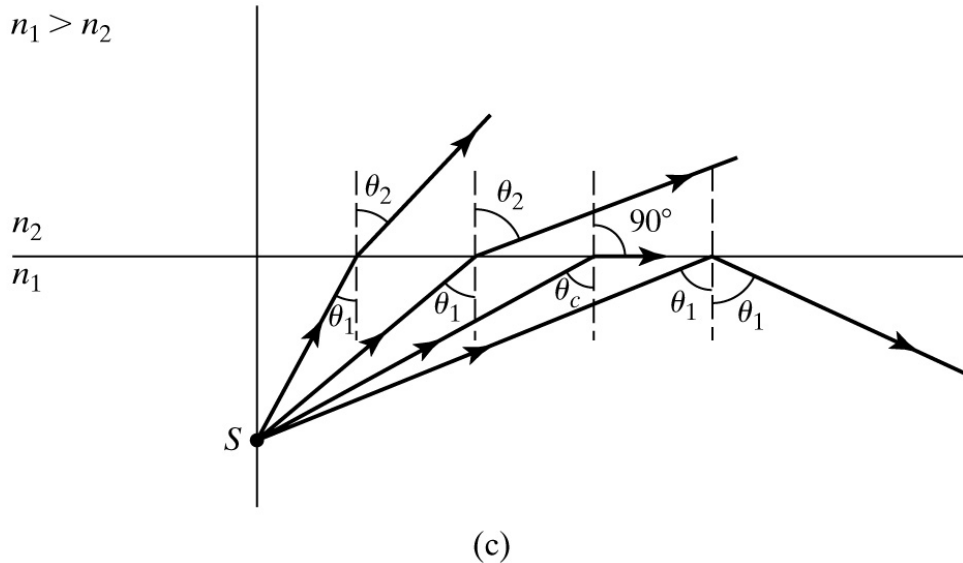

The critical angle θ_{crit} is the value of θ_1 for which θ_2 equals 90° :

Example : Water $n_2 = 1.33 (=4/3)$
Air $n_1 = 1.00$

$$\theta_{\text{crit}} = \arcsin \left(\frac{n_2}{n_1} \sin \theta_2 \right) = \arcsin \frac{n_2}{n_1} = 48.6^\circ.$$

Assignments:

Glass $n = 1.52$

Diamond $n = 2.42$

The largest possible angle of incidence which still results in a refracted ray is called the **critical angle**; in this case the refracted ray travels along the boundary between the two media.

For example, consider a ray of light moving from water to air with an angle of incidence of 50° . The refractive indices of water and air are approximately 1.333 and 1, respectively, so Snell's law gives us the relation

$$\sin \theta_2 = \frac{n_1}{n_2} \sin \theta_1 = 1.333 \cdot 0.766 = 1.021,$$

which is impossible to satisfy.

Reflection and refraction at a flat dielectric interface

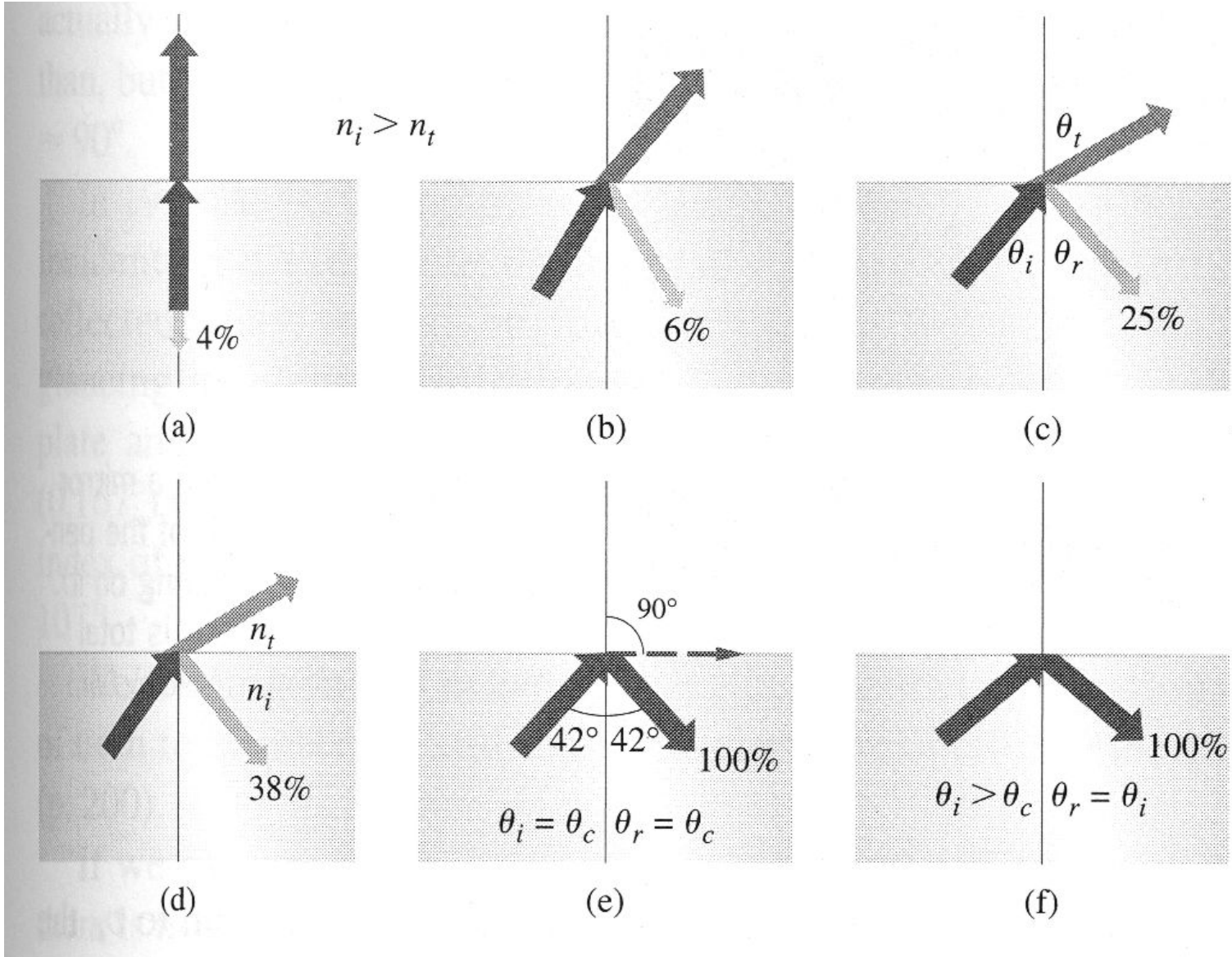

Imaging by an Optical System

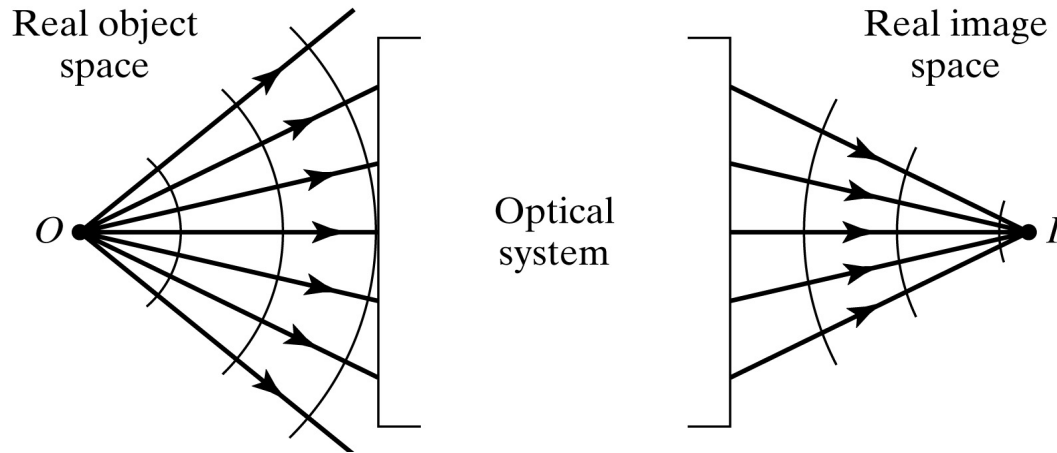

Key words: object point, image point, object space, image space, wavefronts.

Rays spread out radially in all directions from object point O . A Ray diagram deals with selected major rays.

Nonideal images are formed in practice because of

- (1) light scattering,
- (2) aberrations, and
- (3) diffraction.

Trading off *fabrication (grinding)* and *spherical aberrations*.

Molded aspheric lenses are more commonly nowadays.

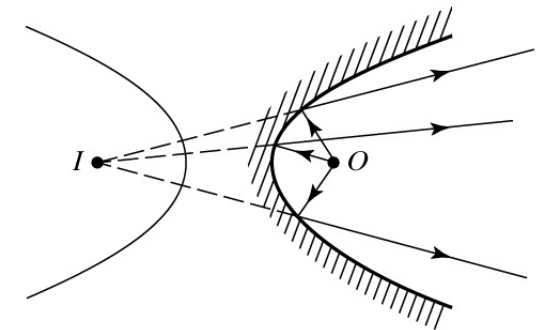
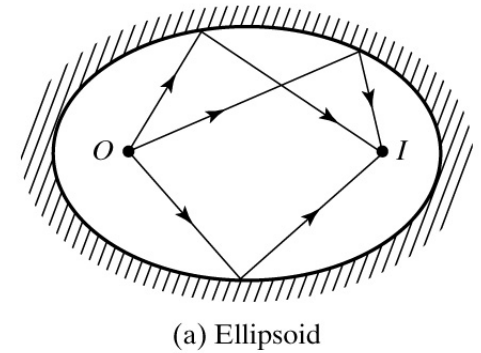

(b) Hyperboloid

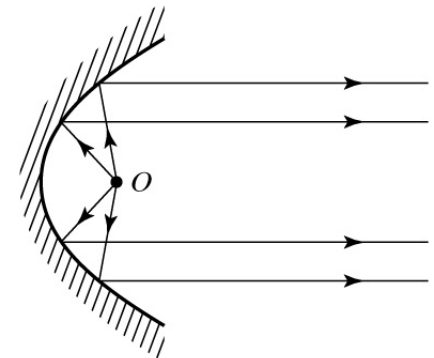

(c) Paraboloid

Reflection at a Spherical Surface

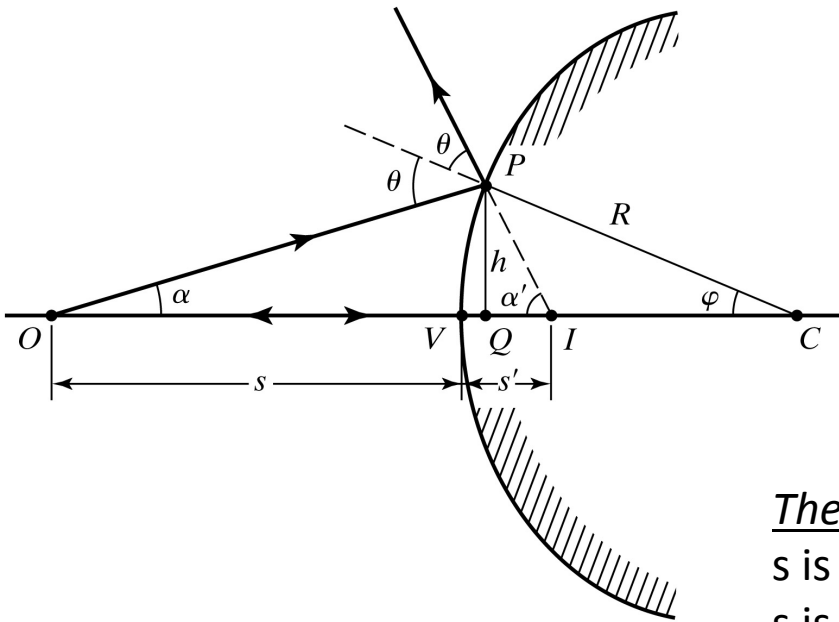

© 2007 Pearson Prentice Hall, Inc.

$$\frac{1}{s} + \frac{1}{s'} = -\frac{2}{R}$$

Sing Convention

(assuming the light propagates from left to right)

The object distance

s is positive when O is to the left of V (real object).
 s is negative when O is to the right of V (virtual object).

The image distance

s' is positive when I is to the left of V (real image).
 s' is negative when I is to the right of V (virtual image).

The radius of curvature

R is positive when C is to the right of V (a convex mirror).
 R is negative when C is to the left of V (a concave mirror).

positive object and image distances → real objects and real images
 convex mirrors → positive radii of curvature (example: a spoon)

Ray Diagrams for Spherical Mirrors

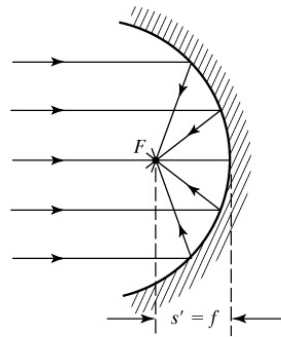

(a)

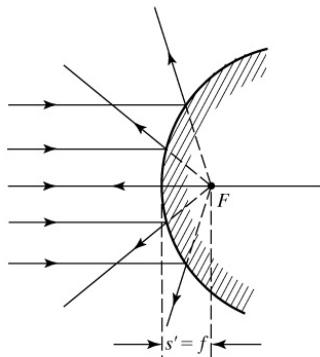

(b)

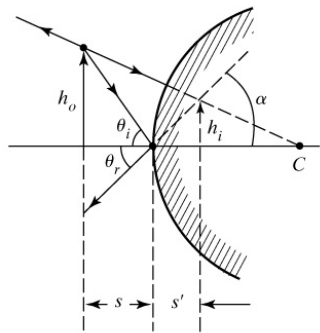

(c)

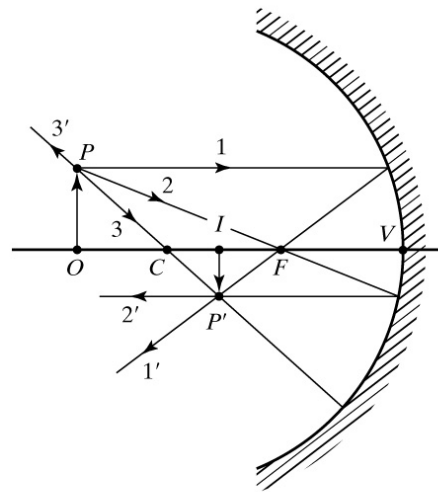

(a)

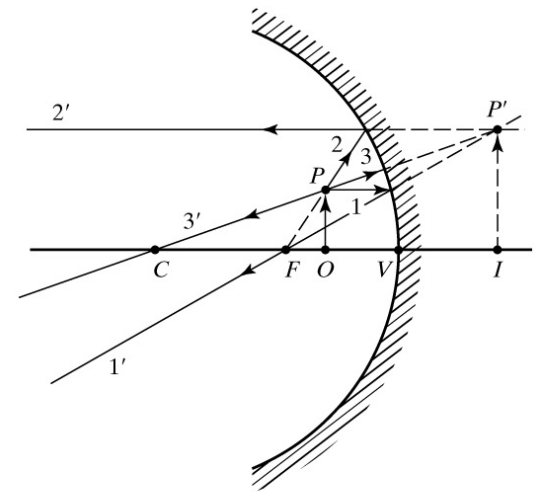

(b)

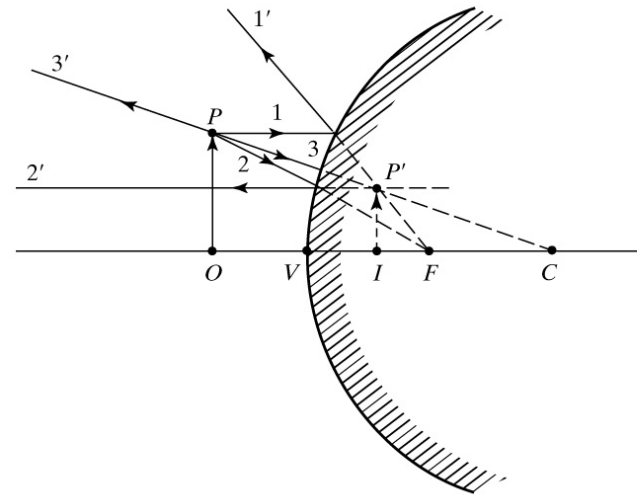

(c)