

Exam II Difficult Problems

Exam II Difficult Problems

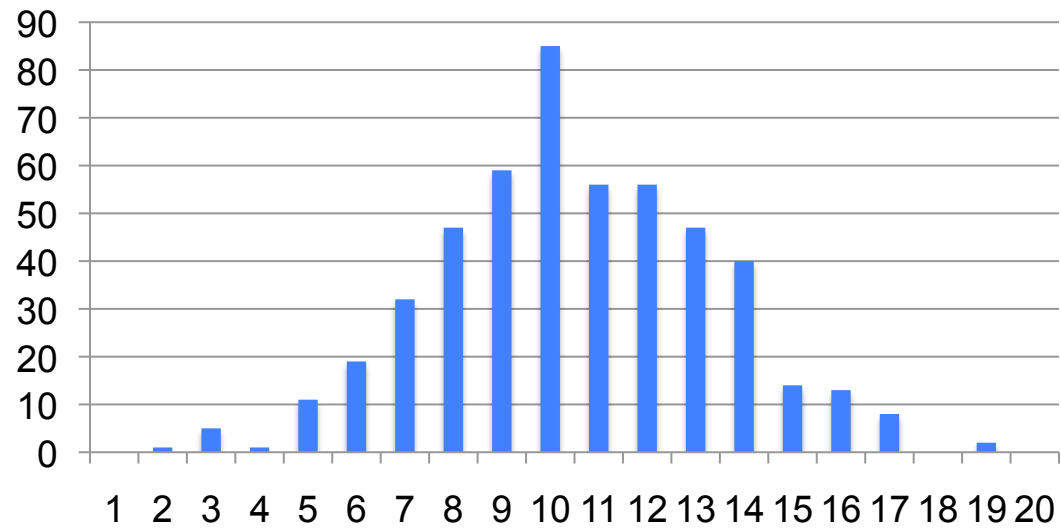

- Two boxes are connected to each other as shown. The system is released from rest and the 1.00-kg box falls through a distance of 1.00 m. The surface of the table is frictionless. What is the kinetic energy of box B just before it reaches the floor?

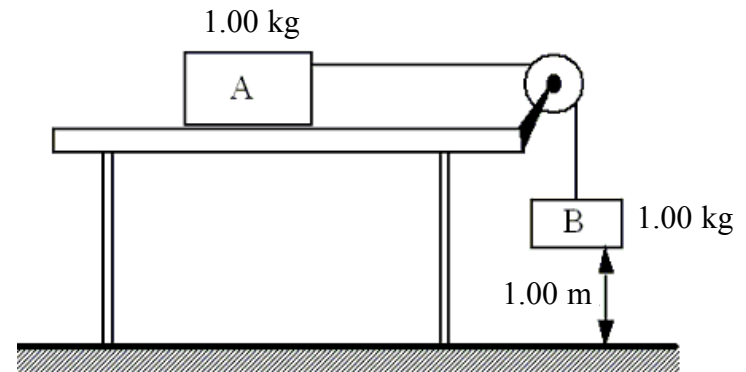

Both masses have the same v . Both masses gain KE.

The PE of mass A does not change, $PE_{Af} = PE_{A0}$

Use energy conservation: $KE_{Af} + KE_{Bf} = PE_{B0} = m_B gh$

Determine velocity of the two masses.

$$KE_f + PE_f = KE_0 + PE_0$$

$$\frac{1}{2}(m_A + m_B)v^2 + 0 = 0 + PE_{B0}$$

$$v^2 = \frac{2}{m_A + m_B} PE_{B0}$$

Use the velocity in KE_B .

$$KE_f = \frac{1}{2} m_B v^2 = \frac{m_B}{m_A + m_B} PE_{B0}$$

$$= \frac{1}{2} 9.8 \text{ J} = 4.90 \text{ J}$$

A block of mass m is released from rest at a height R above a horizontal surface. The acceleration due to gravity is g . The block slides along the inside of a frictionless circular hoop of radius R

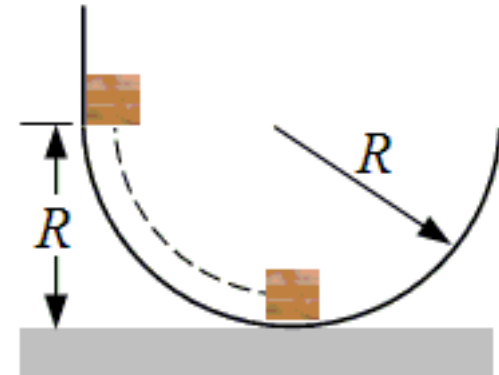

- Which one of the following expressions gives the speed of the mass at the bottom of the hoop?

Use energy conservation, $KE_f + PE_f = KE_0 + PE_0$

$$\frac{1}{2}mv^2 + 0 = 0 + mgR$$

$$v^2 = 2gR$$

- For the mass in the problem above, what is the magnitude of the normal force exerted on the block by the hoop when the block reaches the bottom of the hoop?

F_{\perp} supports weight and provides centripetal force for circular motion.

Centripetal $F_c = ma_c = m\frac{v^2}{R} = m\frac{2gR}{R} = 2mg$

Normal force: $F_{\perp} = F_c + mg = 2mg + mg = 3mg$

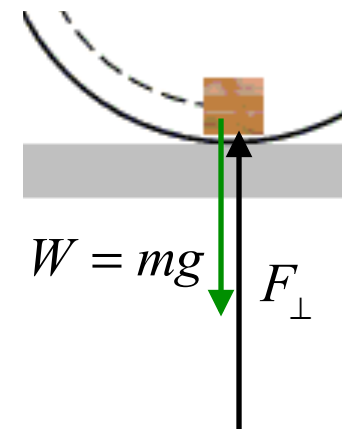

- A tennis ball has a velocity of 12 m/s downward just before it strikes the ground and bounces up with a velocity of 12 m/s upward. Which statement is true concerning this situation?

Momentum is a vector! Ball collides with Earth.
 Momentum of the system is conserved in collisions.

Momentum of ball alone
 is NOT conserved

Momentum of ball & Earth is conserved

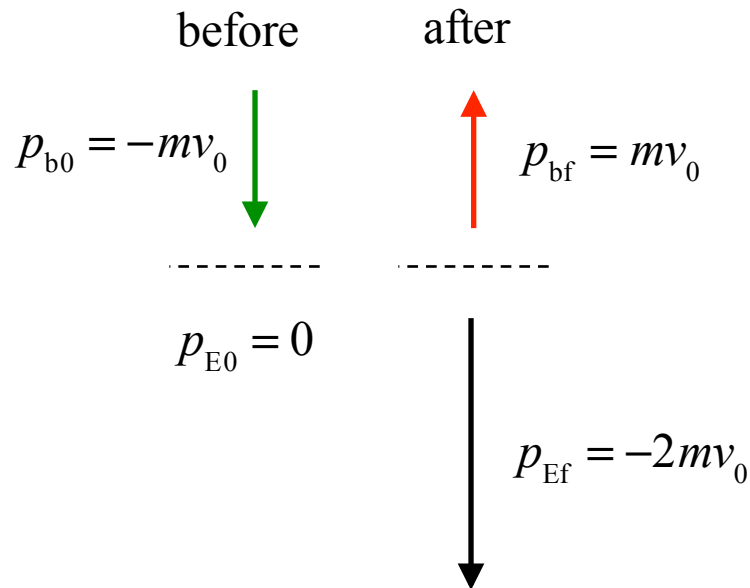

Before: $P_0 = p_{b0} + p_{E0} = -mv_0$
 After: $P_f = p_{bf} + p_{Ef} = +mv_0 + p_{Ef}$

Momentum Conservation

$$P_f = P_0$$

$$+mv_0 + p_{Ef} = -mv_0$$

$$p_{Ef} = -2mv_0$$

- At a specific time, an object moving on a circle of radius 5.0 m, experiences a centripetal acceleration of 2.0 m/s², and an angular acceleration of 0.70 rad/s². What is the total linear acceleration of the object?

Centripetal and Tangential acceleration vectors are perpendicular to each other!

$$a_C = 2.0 \text{ m/s}^2, \alpha = 0.7 \text{ rad/s}^2, r = 5.0 \text{ m}$$

$$a_T = \alpha r = 3.5 \text{ m/s}^2$$

$$a = \sqrt{a_T^2 + a_C^2} = \sqrt{(3.5)^2 + (2.0)^2} \text{ m/s} = 4.0 \text{ m/s}$$

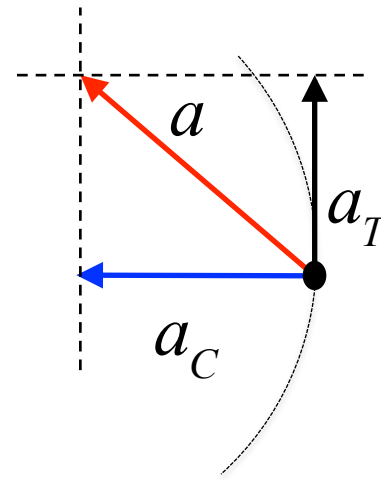

- Three objects are attached to a *massless* rigid rod that has an axis of rotation as shown. Assuming all of the mass of each object is located at the point shown for each, calculate the moment of inertia of this system.

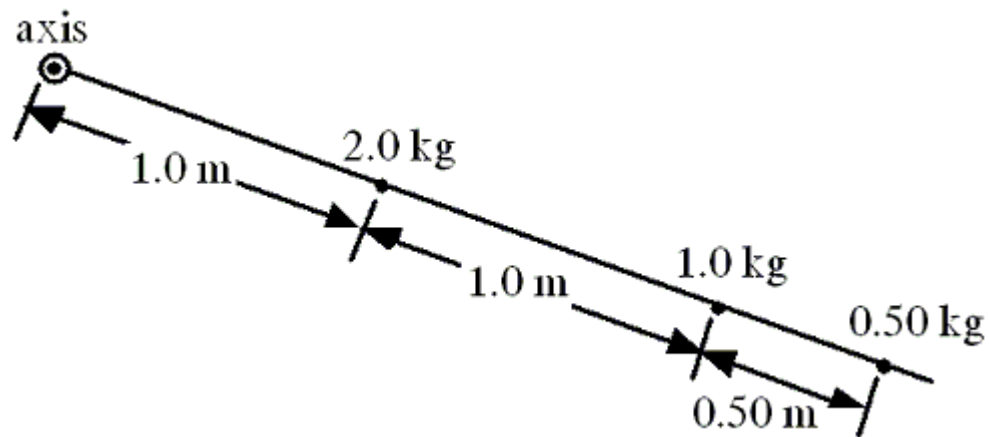

$$I = \sum mr^2 = (2.0 \text{ kg})(1.0 \text{ m})^2 + (1.0 \text{ kg})(2.0 \text{ m})^2 + (0.5 \text{ kg})(2.5 \text{ m})^2$$
$$= (2 + 4 + 3.1) \text{ kg} \cdot \text{m}^2 = 9.1 \text{ kg} \cdot \text{m}^2$$

- A rock is dropped from a high tower and falls freely under the influence of gravity. Which one of the following statements concerning the rock as it falls is true? Neglect the effects of air resistance.

Momentum changed by Impulse

$$\Delta p = F \Delta t = (mg) \Delta t$$

- A) The rock will gain an equal amount of momentum during each second.
- B) The rock will gain an equal amount of kinetic energy during each second.
- C) The rock will gain an equal amount of speed for each meter through which it falls.
- D) The rock will gain an equal amount of momentum for each meter through which it falls.
- E) The amount of momentum the rock gains will be proportional to the amount of potential energy that it loses .

- Which one of the following statements concerning kinetic energy is true?
 - A) Kinetic energy can be measured in watts.
 - B) Kinetic energy is always equal to the potential energy.
 - C) Kinetic energy is always positive.
 - D) Kinetic energy is a quantitative measure of inertia.
 - E) Kinetic energy is directly proportional to velocity.

• A child standing on the edge of a freely spinning merry-go-round moves quickly to the center. Which one of the following statements is necessarily true concerning this event and why?

A) The angular speed of the system decreases because the moment of inertia of the system has increased.

B) The angular speed of the system increases because the moment of inertia of the system has increased.

C) The angular speed of the system decreases because the moment of inertia of the system has decreased.

D) The angular speed of the system increases because the moment of inertia of the system has decreased.

E) The angular speed of the system remains the same because the net torque on the merry-go-round is zero $\text{N} \cdot \text{m}$.

No external torque: angular momentum conserved

$$I_0 \omega_0 = I_f \omega_f; \quad \omega_f = (I_0 / I_f) \omega_0$$

Moment of inertia decreases: $I_0 > I_f \Rightarrow$ speed increases: $\omega_f > \omega_0$

Next 8 chapters use all concepts developed in the first 9 chapters, applying them to physical systems.

	3/22	Th	Midterm Exam 2	Ch. 1-9
12	3/27	T	Simple Harmonic Motion	Ch. 10, Sec. 1-9
	3/29	Th	Fluids	Ch. 11, Sec. 1-12
13	4/3	T	Temperature Heat	Ch. 12, Sec. 1-11
	4/5	Th	Heat Transfer	Ch. 13, Sec. 1-5
14	4/10	T	Ideal Gas Law/Kinetic Theory	Ch. 14, Sec. 1-5
	4/12	Th	Thermodynamics & the 1st Law	Ch. 15, Sec. 1-6
15	4/17	T	2nd Law of Thermodynamics	Ch. 15, Sec 7-13
	4/19	Th	Waves and Sound	Ch. 16, Sec 1-12
16	4/24	T	Diffraction & Interference	Ch. 17, Sec 1-8
	4/26	Th	Review	Ch. 1-17
17	5/3	Th	Final Exam 8:00-10:00 pm, Rm TBD	Ch. 1-17

Chapter 10

Simple Harmonic Motion and Elasticity

10.1 The Ideal Spring and Simple Harmonic Motion

$$F_x^{Applied} = kx$$

spring constant

Units: N/m

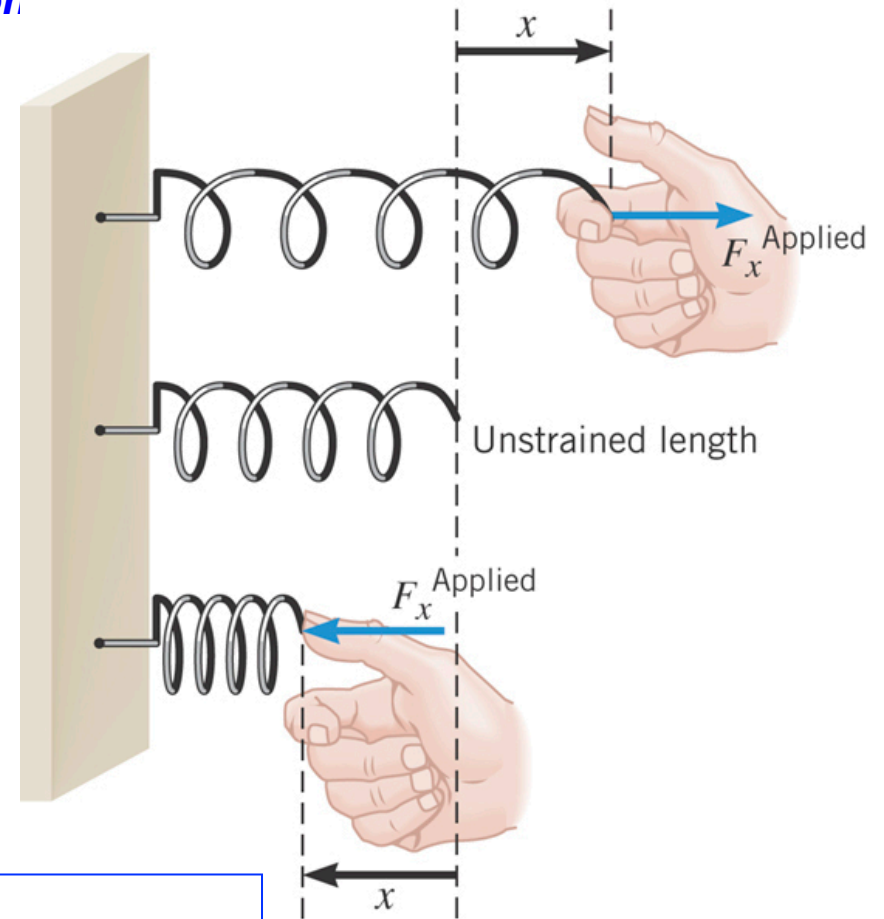

This is a scalar equation

$F_x^{Applied}$ is magnitude of **applied force**.

x is the magnitude of the spring displacement

k is the spring constant (strength of the spring)

10.1 The Ideal Spring and Simple Harmonic Motion

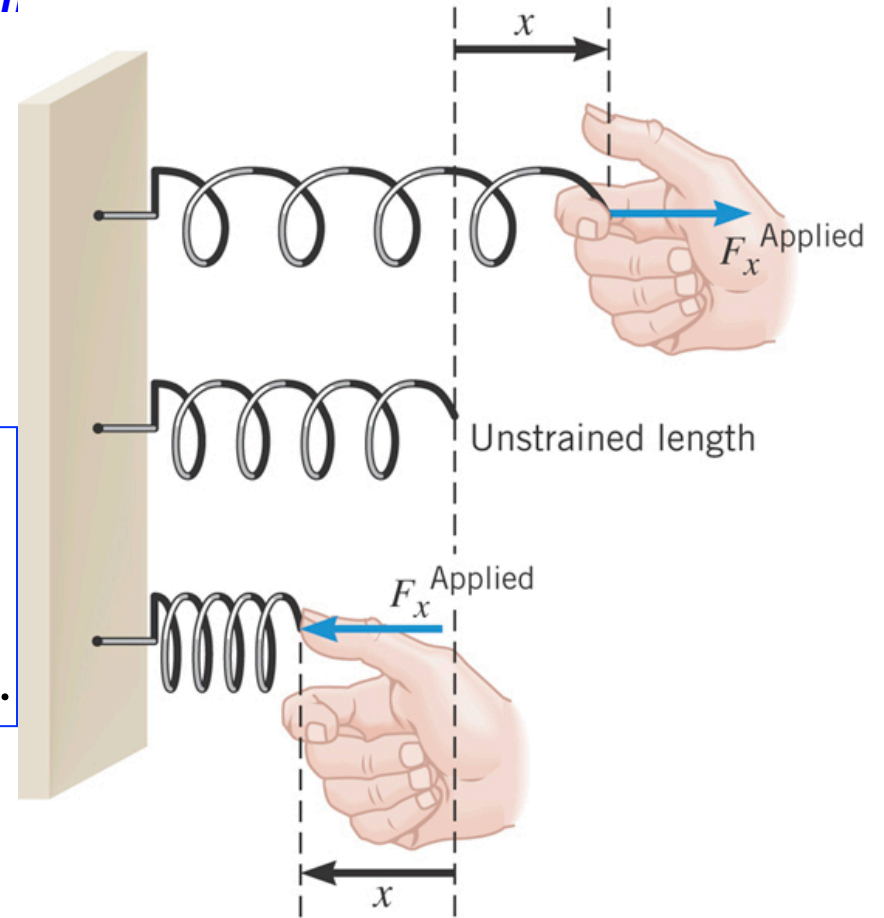
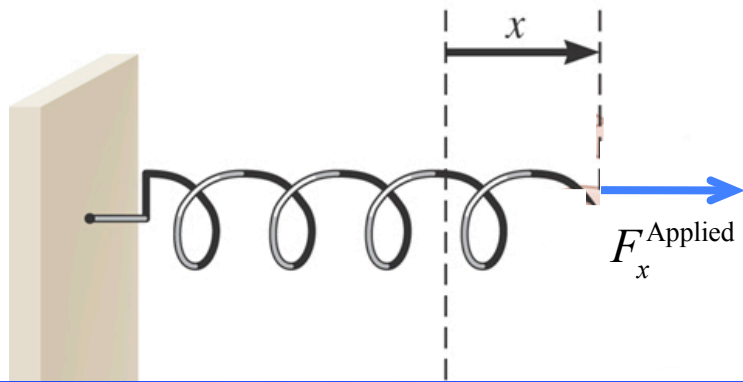

F_x^{Applied} is applied to the spring.
This force can come from anywhere.
The wall generates a force on the spring.

F_x^{Applied} acts ON the SPRING
NOT on the HAND

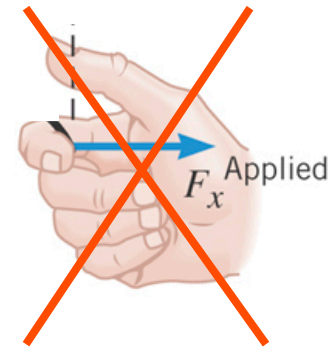

10.1 The Ideal Spring and Simple Harmonic Motion

Example 1 A Tire Pressure Gauge

The **spring constant** of the spring is 320 N/m and the bar indicator extends 2.0 cm. What force does the air in the tire apply to the spring?

$$\begin{aligned} F_x^{Applied} &= kx \\ &= (320 \text{ N/m})(0.020 \text{ m}) = 6.4 \text{ N} \end{aligned}$$

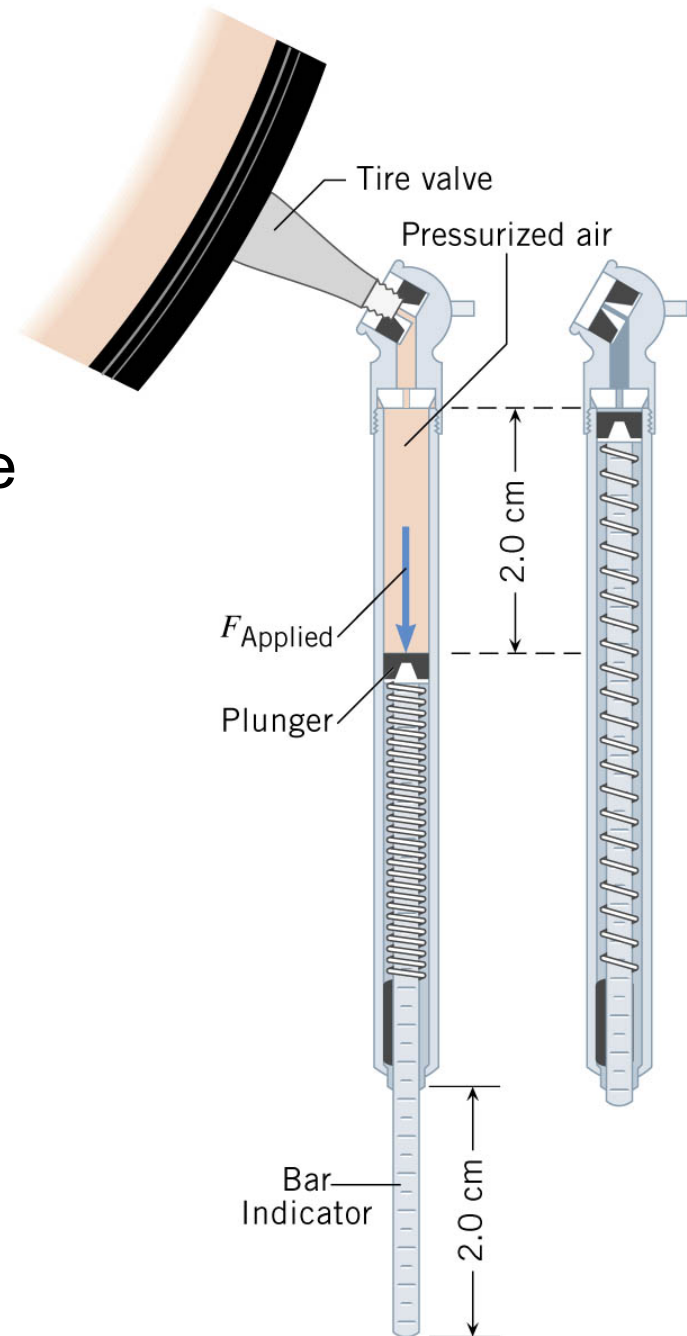

Clicker Question 10.1 Spring constants

$$F = kx$$

A spring with spring constant, k_0 , is stretched by an applied force, F . Another spring, spring constant k_1 , stretches twice as much by the same applied force. What is true about k_1 ?

- a) $k_1 = k_0$
- b) $k_1 = 2k_0$
- c) $k_1 = \frac{1}{2}k_0$
- d) $k_1 = \sqrt{2} k_0$
- e) $k_1 = k_0^2$

Clicker Question 10.1 Spring constants

$$F_A = kx$$

A spring with spring constant, k_0 , is stretched by an applied force, F . Another spring, spring constant k_1 , stretches twice as much by the same applied force. What is true about k_1 ?

- a) $k_1 = k_0$
- b) $k_1 = 2k_0$
- c) $k_1 = \frac{1}{2}k_0$
- d) $k_1 = \sqrt{2}k_0$
- e) $k_1 = k_0^2$

$$\begin{aligned}k_0 &= \frac{F_A}{x} \\k_1 &= \frac{F_A}{x'}; \quad x' = 2x \\&= \frac{F_A}{2x} = \frac{1}{2} \left(\frac{F_A}{x} \right) \\&= \frac{1}{2}k_0\end{aligned}$$

new spring stretches twice as much.
spring is WEAKER, $k_1 = \frac{1}{2}k_0$

10.1 The Ideal Spring and Simple Harmonic Motion

Conceptual Example 2 Are Shorter Springs Stiffer?

A 10-coil spring has a spring constant k . If the spring is cut in half, so there are two 5-coil springs, what is the spring constant of each of the smaller springs?

$$F_A = kx; \quad k = \frac{F_A}{x}$$

Each piece $x' = x/2$. Same force applied.

New spring constant of each piece

$$\begin{aligned} k' &= \frac{F_A}{x'} = \frac{F_A}{x/2} \\ &= 2 \left(\frac{F_A}{x} \right) = 2k \text{ (twice as strong)} \end{aligned}$$

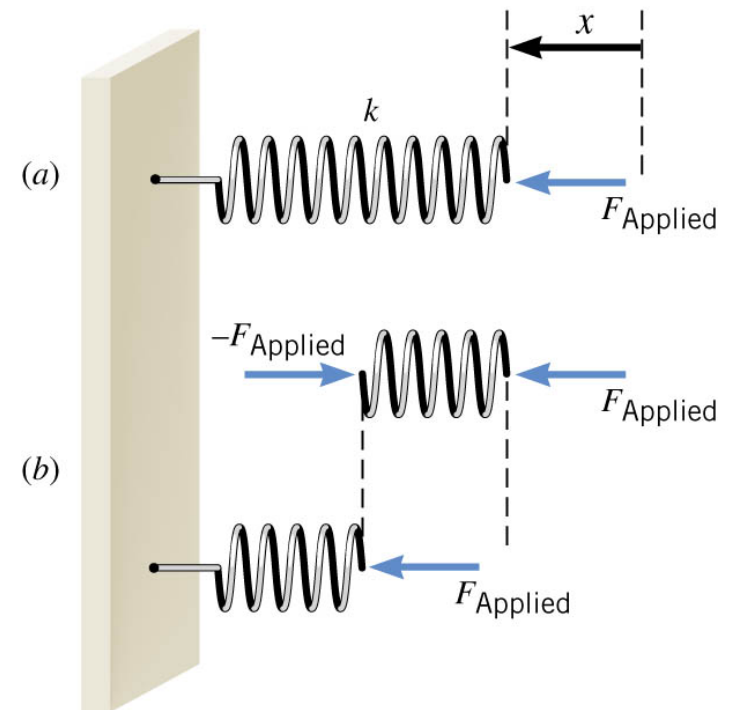

10.1 The Ideal Spring and Simple Harmonic Motion

HOOKE'S LAW: RESTORING FORCE OF AN IDEAL SPRING

The **restoring force** of an ideal spring is $F_x = -kx$

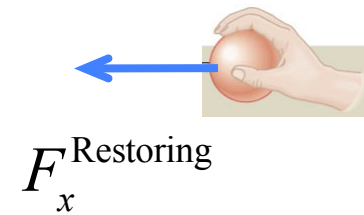
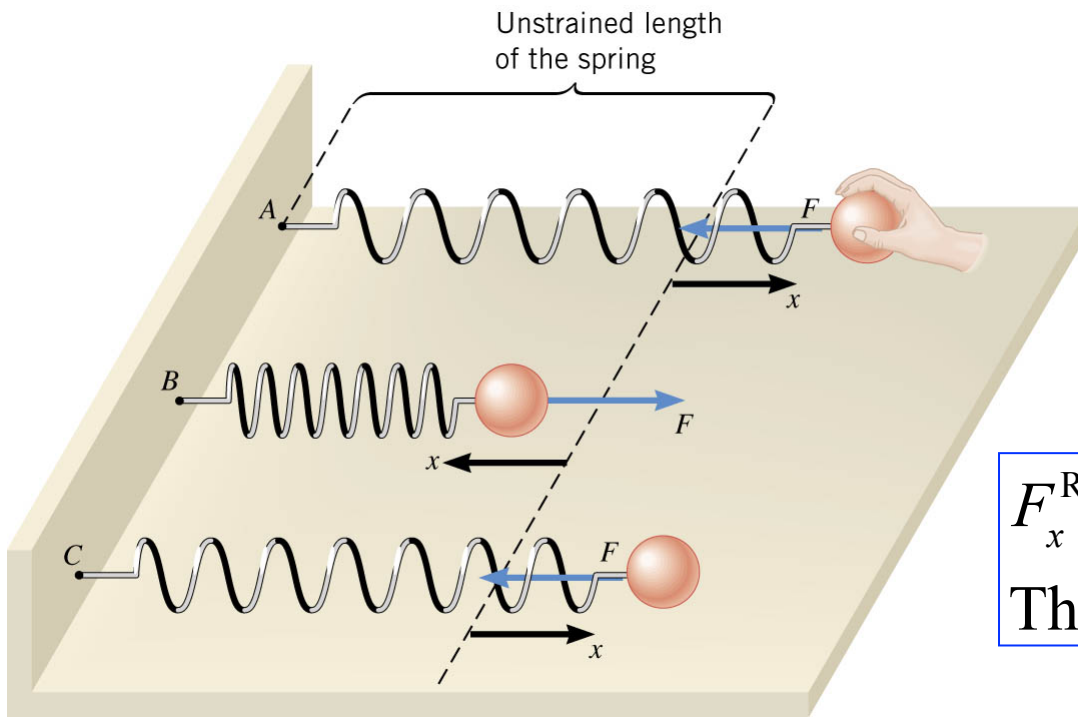

$F_x^{\text{Restoring}}$ generated by the spring.
This force acts on the ball & hand

10.2 Simple Harmonic Motion and the Reference Circle

DISPLACEMENT

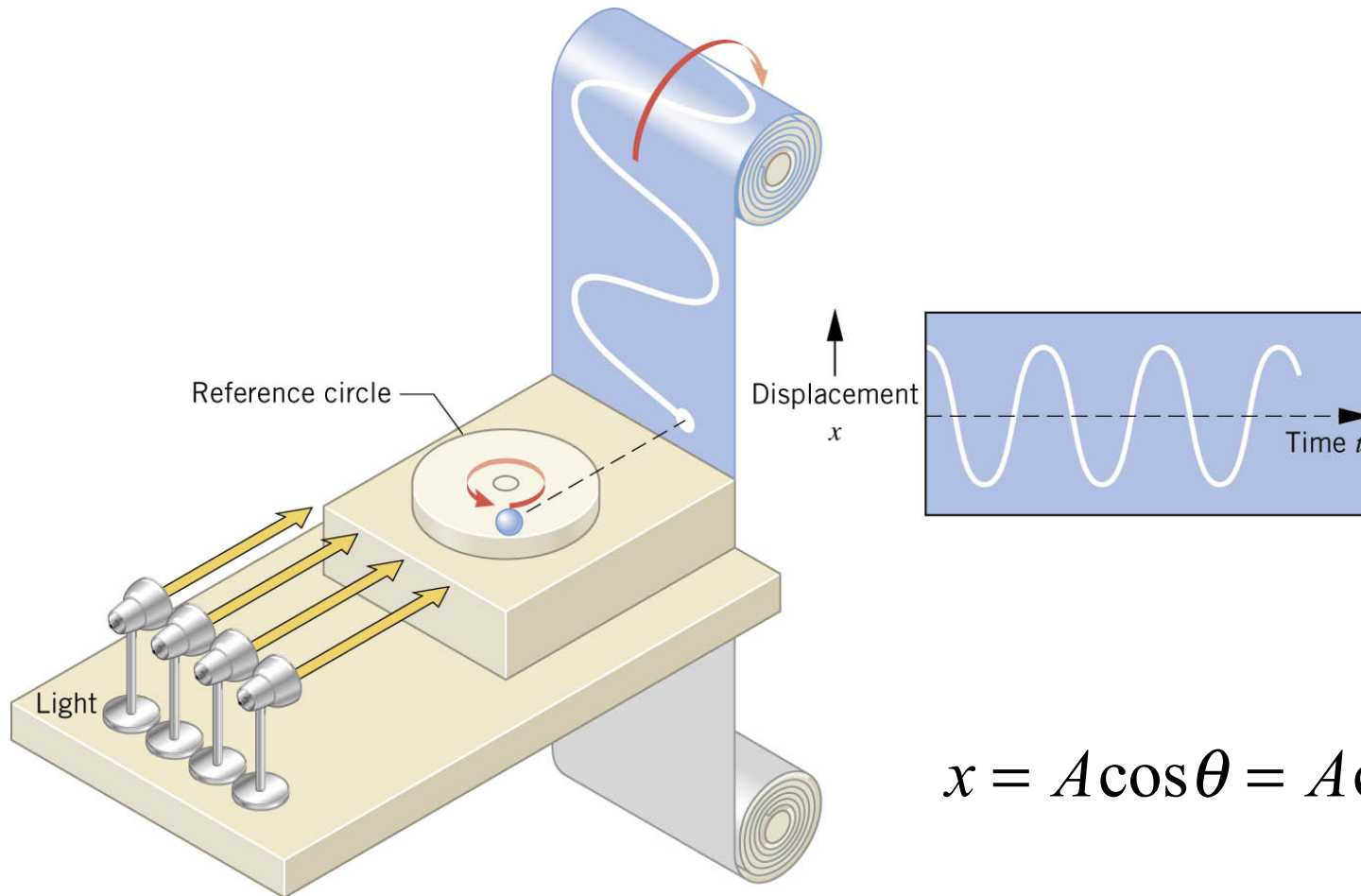

$$x = A \cos \theta = A \cos \omega t$$

Angular velocity, ω (unit: rad/s)

Angular displacement, $\theta = \omega t$ (unit: radians)

10.2 Simple Harmonic Motion and the Reference Circle

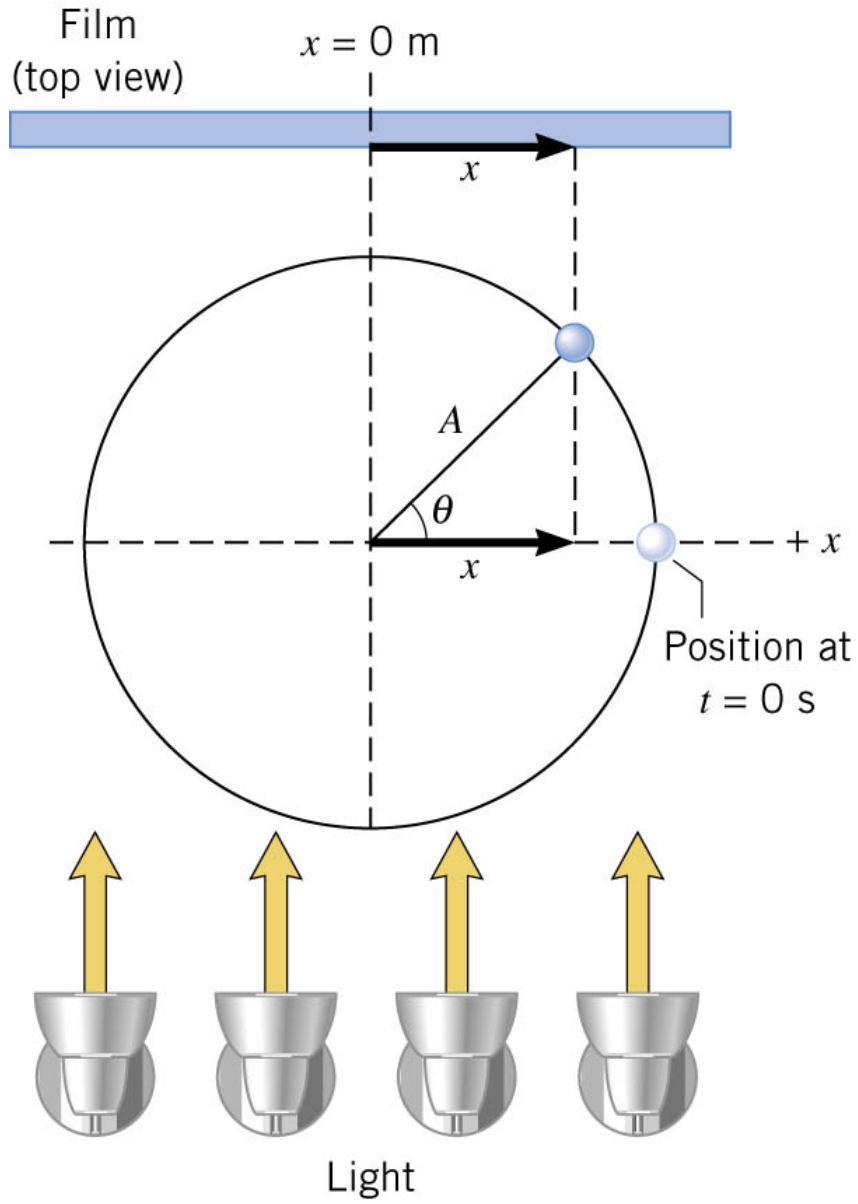

$$x = A \cos \theta = A \cos(\omega t)$$

10.2 Simple Harmonic Motion and the Reference Circle

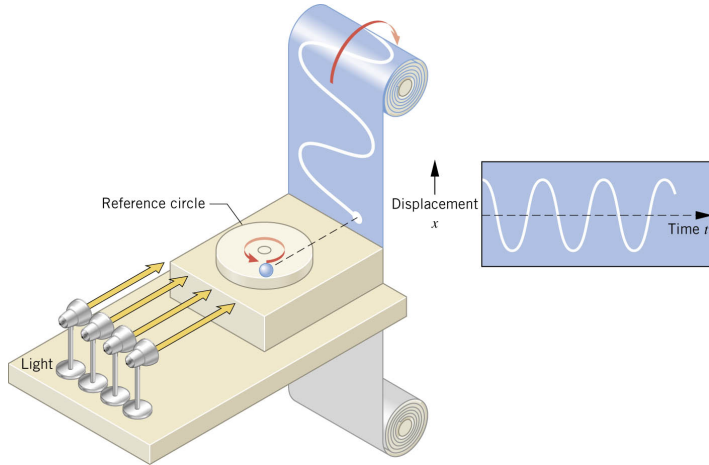

amplitude A:

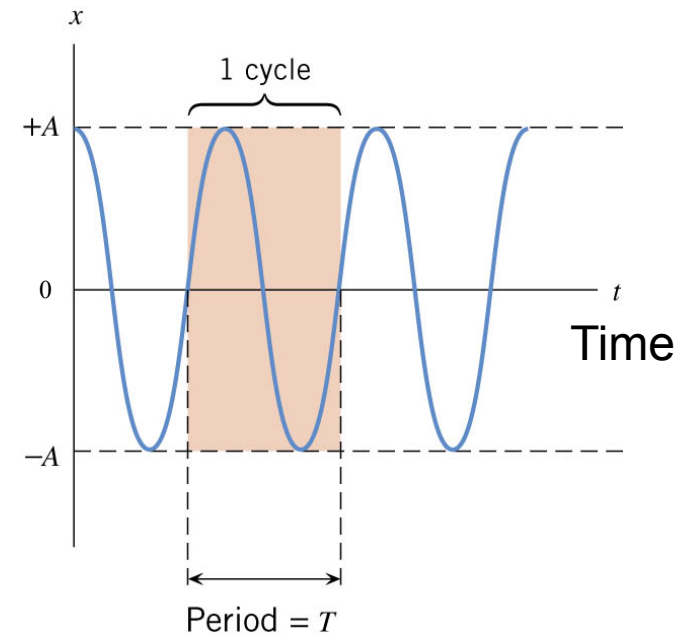

amplitude A: the maximum displacement

period T: the time required to complete one "cycle"

frequency f: the number of "cycles" per second (measured in Hz = 1/s)

frequency f: $f = \frac{1}{T}$

$\omega = 2\pi f = \frac{2\pi}{T}$ (Radians per second)

10.2 Simple Harmonic Motion and the Reference Circle

VELOCITY

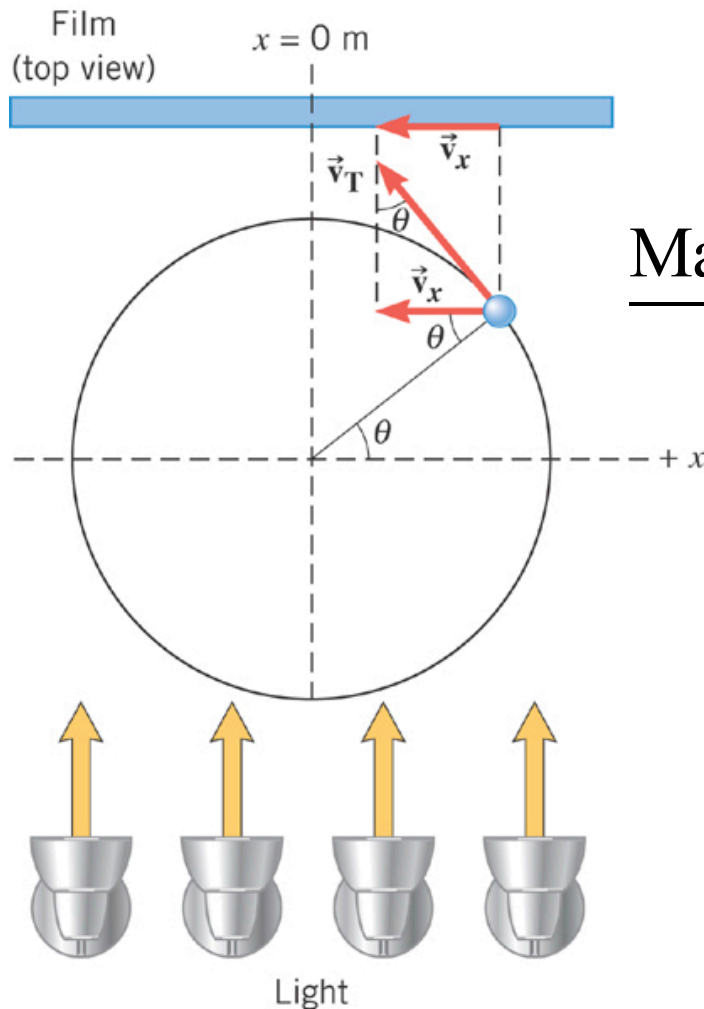

$$v_x = -v_T \sin \theta = -\underbrace{A\omega}_{v_{\max}} \sin(\omega t)$$

Maximum velocity: $\mp A\omega$ (units, m/s)

$$v_x = A\omega \sin(\omega t) = \mp A\omega$$

when $\omega t = \pi/2, 3\pi/2$ radians

Maximum velocity occurs at

$$\begin{aligned} x &= A \cos(\omega t) \\ &= A \cos(\pi/2) = 0 \end{aligned}$$

10.2 Simple Harmonic Motion and the Reference Circle

Example 3 The Maximum Speed of a Loudspeaker Diaphragm

The frequency of motion is 1.0 KHz and the amplitude is 0.20 mm.

(a) What is the maximum speed of the diaphragm?

(b) Where in the motion does this maximum speed occur?

$$v_x = -v_T \sin \theta = -\underbrace{A\omega}_{v_{\max}} \sin \omega t$$

$$\begin{aligned} \text{a) } v_{\max} &= A\omega = A(2\pi f) \\ &= (0.20 \times 10^{-3} \text{ m})(2\pi)(1.0 \times 10^3 \text{ Hz}) \\ &= 1.3 \text{ m/s} \end{aligned}$$

b) The maximum speed occurs midway between the ends of its motion.

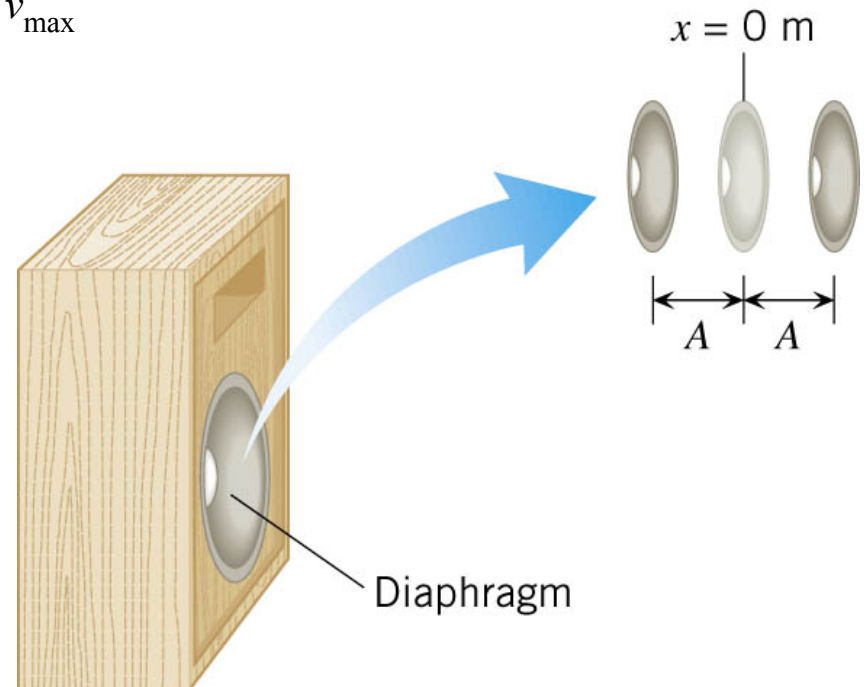

10.2 Simple Harmonic Motion and the Reference Circle

ACCELERATION

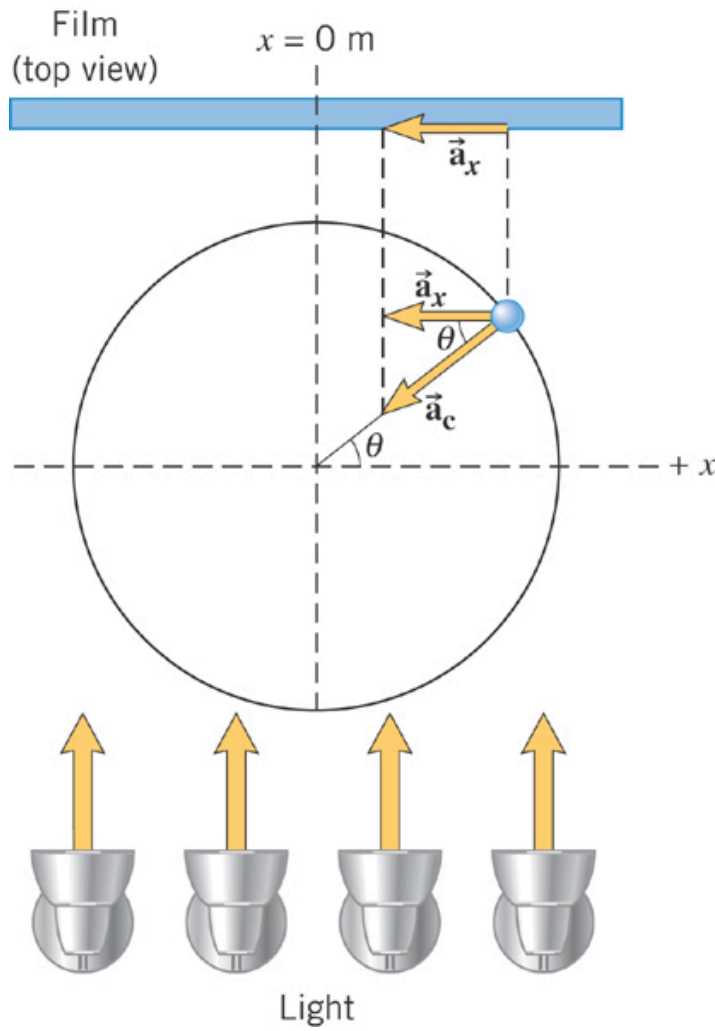

$$a_x = -a_c \cos \theta = -\underbrace{A}_{a_{\max}} \omega^2 \cos \omega t$$

Maximum a_x : $\mp A\omega^2$ (units, m/s^2)

$$a_x = A\omega^2 \cos(\omega t) = \mp A\omega^2$$

when $\omega t = 0, \pi$ radians

Maximum a_x occurs at

$$x = A \cos(\omega t)$$

$$= A \cos(0) = A$$

$$= A \cos(\pi) = -A$$

10.2 Simple Harmonic Motion and the Reference Circle

FREQUENCY OF VIBRATION

$$x = A \cos \omega t$$

$$a_x = -A\omega^2 \cos \omega t$$

$$\sum F = -kx = ma_x$$

$$-kA = -mA\omega^2$$

$$\omega = \sqrt{\frac{k}{m}}$$

10.2 *Simple Harmonic Motion and the Reference Circle*

Example 6 A Body Mass Measurement Device

The device consists of a spring-mounted chair in which the astronaut sits. The spring has a spring constant of 606 N/m and the mass of the chair is 12.0 kg . The measured period is 2.41 s . Find the mass of the astronaut.



10.2 Simple Harmonic Motion and the Reference Circle

$$\omega = \sqrt{\frac{k}{m_{\text{total}}}} \quad \longrightarrow \quad m_{\text{total}} = k/\omega^2$$

$\omega = 2\pi f = \frac{2\pi}{T}$

$$m_{\text{total}} = \frac{k}{(2\pi/T)^2} = m_{\text{chair}} + m_{\text{astro}}$$

$$m_{\text{astro}} = \frac{k}{(2\pi/T)^2} - m_{\text{chair}}$$

$$= \frac{(606 \text{ N/m})(2.41 \text{ s})^2}{4\pi^2} - 12.0 \text{ kg} = 77.2 \text{ kg}$$