

Mass of the Electron

Motivation for the Experiment

The aim of this experiment is to measure the mass of the electron. The mass will be deduced from a measurement of the charge to mass ratio, e/m , combined with a value for the charge taken from elsewhere.

Table I gives the values for the mass and charge of the electron for comparison purposes. They are known to much higher accuracy than we can hope to measure in our experiments and, therefore, they will be considered to be exact.

Table I
Electron Charge and Mass

<u>Quantity</u>	<u>Symbol</u>	<u>Value</u>	<u>Units</u>
Mass	m_e	9.109×10^{-31}	kg
Charge	e	1.602×10^{-19}	C

I. The Charge to Mass Ratio (e/m) for the Electron

Introduction

In 1897 J. J. Thompson discovered the first "elementary particle", the electron, by measuring the ratio of its charge to mass in a manner similar to the experiment that we will perform. Given the mass and charge in Table I we expect to measure a value that is close to:

$$\frac{e}{m_e} = \frac{1.602 \times 10^{-19} \text{C}}{9.109 \times 10^{-31} \text{kg}} = 1.759 \times 10^{11} \frac{\text{C}}{\text{kg}} \quad (\text{I-1})$$

Theory

Both conceptually and experimentally this part of the experiment is quite simple. A hollow glass sphere is evacuated to a high vacuum and filled with a small amount of Neon gas or Mercury vapor at a pressure of about 1 millitorr. Inside the sphere, a heated wire (a "filament") emits a large number of electrons which are accelerated by a potential difference V , to acquire kinetic energy:

$$\frac{1}{2} m_e v^2 = e \cdot V \quad (\text{I-2})$$

and, therefore, a velocity:

$$v = \sqrt{\left[2V \cdot \frac{e}{m_e} \right]} \quad (\text{I-3})$$

The moving electrons strike and ionize the Ne atoms which give off light when they recombine, producing a visible beam along the electron track. The sphere is placed in a region where a magnetic field, \mathbf{B} , is produced by a current in two coils of wire. \mathbf{B} is applied perpendicular to the velocity vector of the electrons resulting in a magnetic force:

$$\mathbf{F} = e \mathbf{v} \times \mathbf{B} \quad (\text{I-4})$$

The force is perpendicular to both the velocity and the magnetic field vectors and produces an acceleration \mathbf{a} , whose magnitude is given by:

$$|a| = \frac{|F|}{m_e} = \frac{v^2}{r} \quad (\text{I-5})$$

where r is the radius of the circular path of the electron. (Recall that such a force is called a **centripetal** force and the corresponding acceleration a **centripetal** acceleration with both vectors directed toward the center of the circle.)

Therefore:

$$m_e \frac{v^2}{r} = e \cdot v \cdot B \quad (\text{I-6})$$

which yields:

$$\frac{e}{m_e} = \frac{v}{B \cdot r} \quad (\text{I-7})$$

Substituting for v from Eq. 3, we obtain:

$$\frac{e}{m_e} = \frac{1}{B \cdot r} \sqrt{\frac{2eV}{m_e}} \quad (\text{I-8})$$

which simplifies to:

$$\frac{e}{m_e} = \frac{2V}{(B \cdot r)^2} \quad (\text{I-9})$$

This equation is correct **IF** V and B are both constant in space and time so that all the electrons have the same velocity v , and follow the same circular path of radius r .

V is applied between two conducting equipotential surfaces by a stable power supply and is therefore well defined.

Two coils of radius R , separated by a distance d , each having N turns with current I passing through them in the same sense, generate a magnetic field on their common axis, half way between them, equal to:

$$B_0 = \frac{\mu_0 N I}{R} \left[\frac{1}{1 + \left(\frac{d}{2R}\right)^2} \right]^{\frac{3}{2}} \quad (\text{I-10})$$

here $\mu_0 = 4\pi \times 10^{-7}$ henries/per meter is the permeability constant. You should verify that when $d = R$, this expression reduces to that for a Helmholtz pair, $(4/5)^{3/2} \mu_0 NI/R$. This configuration provides a rather uniform field, especially on the mid-plane between the coils.

Extra Credit: correction for field variation. Equation I-10 gives the field at midpoint of the central axis of the coils. There are corrections of a few % to the field seen by the electron in its orbit as it moves in the plane equidistant from the coils, because the field changes once you move away from the center. To avoid large corrections, confine your measurements to radii less than about 70% of the radius of the coils thereby limiting corrections to 5% or less.

To correct for the effects of the field away from the center, we need to know how the field varies as a function of the radius s in the mid plane between the two coils. Figure 1 shows this variation as a function of the fractional radius, s/R , where s is the distance from the central axis of the Helmholtz pair to the point of interest. Note that in each case the field is normalized to the value at $s = 0$. Note that because our electrons travel in a circle starting from the accelerating electrode (which has a fixed position), these

orbits are not at a constant s , except for one particular value of r . Thus, using this correction is approximate, and requires estimating an average value of s for the orbit. To do so will require a good sketch of the apparatus.

EC Questions: Explain the systematic errors due to neglecting this correction: would e/m be too low or too high? Can you give an upper bound for how large the effect might be in your data? How would this vary with the orbit radius r ?

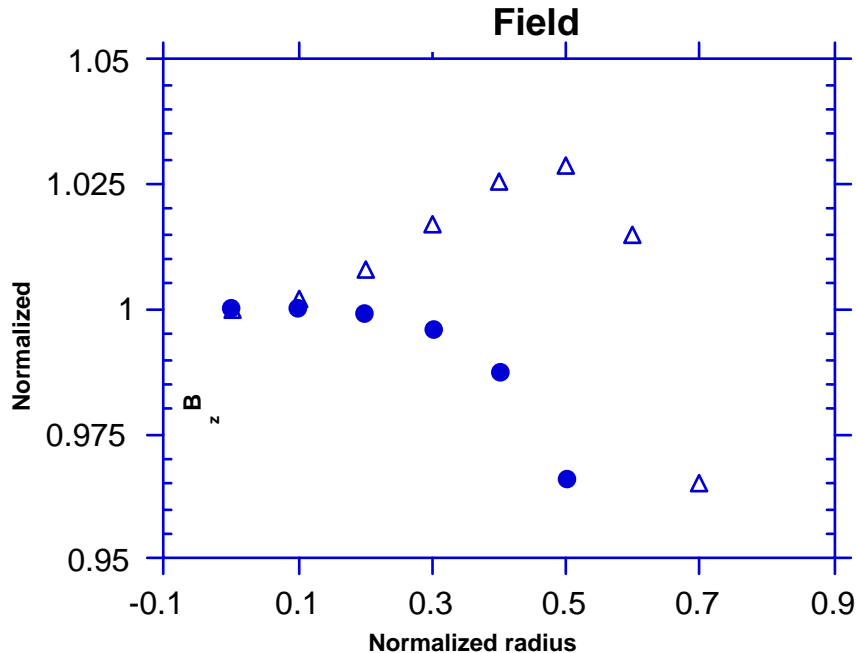

Fig. I-1: Normalized magnetic field in mid plane for Helmholtz pair (closed circles) and a different configuration (open triangles) as a function of the normalized distance from the axis, s/R .

Apparatus

e/m tube

Magnetic field coils with 124 turns per coil: $N = 124$.

Power supplies and meters

The Experiment

The e/m tube consists of the glass bulb, the hot wire filament, the accelerating electrodes and a set of reference marks to indicate the diameter of the electron path which is made visible by ionization of the Neon gas.

The Kepco power supply provides the current for the magnet coils while the Heathkit power supply provides the accelerating voltage. The Pasco power supply provides the ac voltage to heat the filament.

Measure the radius of one of the coils as well as their separation in order to calculate the central magnetic field from Eq. I-10. Think about exactly what distance you should measure, i.e. how to deal with the thickness of the coils.

The power supplies are connected as shown in the schematic (Fig. I-2 below). The two coils are in series with each other so that each coil has exactly the same current. There is an ammeter in series with the coils, and a voltmeter in parallel with the accelerating voltage and across the heater voltage. Use an

AC frequency different from 60 Hz to avoid beat frequency oscillations in the beam. Record the heater voltage used.

Turn down all the voltages to their minimum, then turn on the power supplies. Let the heater voltage (marked “amplitude” on the Pasco supply) warm up a few minutes and then apply about +150 V accelerating voltage (on the Heathkit supply). Adjust the heater voltage so that you obtain a fairly sharp beam of electrons (not too fuzzy). This controls the intensity of the beam. You may have to raise it a fair bit to get a beam started and then you can lower it back down. In any case, stop raising the voltage when the orbit stops changing (we do not understand the coupling!). Once you’re satisfied with the electron beam, don’t touch the heater current knob until the end of the experiment.

Adjust the current creating the magnetic field until the electron beam forms a circular path. Adjust the bulb orientation in the magnetic field so that the electron path is circular and not spiral.

Compute the actual magnetic field at each radius using Eq I-10 and I-9.

Collect data for several different voltages and magnet currents. The “rungs” on the ladder in the tube are 2 cm apart; the top tick is 10cm above beam. The easiest way to take data is to set the accelerating voltages to 150V, 200V and 250V and then to adjust the magnetic field currents so that the top of the electron beam is either level with one of the rungs, or halfway between two rungs. Take as many readings (magnetic field currents) for each accelerating voltage as possible.

Turn down all the voltages, and then turn off the power supplies: this helps the tubes live longer.

Calculate your e/m value before leaving the lab!

Plot your values for e/m_e as a function of the radius using different symbols for the different accelerating voltages. Do a simple statistical analysis to (mean, standard deviation for each voltage) determine the errors in your measurement and put these as error bars on your plot.

Question 1: Which of your input measured quantities (I, V, beam radius, coil dimensions, etc) has the largest fractional uncertainty?

Question 2: Estimate your fractional uncertainty in e/m by finding the fractional error contribution due to your largest fractional uncertainty (identified in Question 1), and discuss whether this uncertainty does a reasonable job of predicting the standard deviation of your e/m measurements. *Hint: if you need the uncertainty of the magnetic field, estimate it by considering the expression in brackets in Eq I-10 to be a constant.*

Question 3: Do your data vary by more than the statistical error bars? If so, these variations may indicate the presence of a systematic error in your measurements. Do your data suggest the presence of such a systematic error? If they do, you will need to assign a reasonable value to these systematic errors based on your data and take them into account when you compute your value for m_e at the conclusion of this lab.

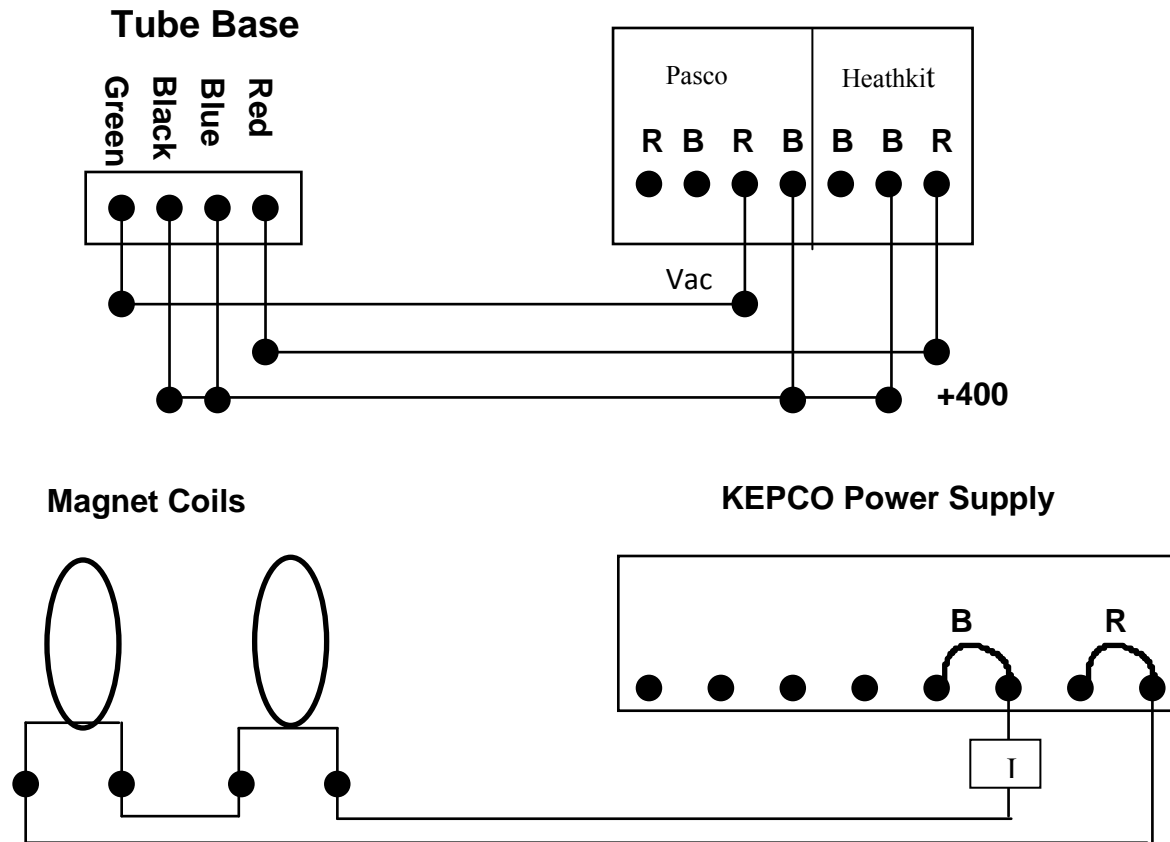

Fig. I-2: Schematic Circuit Diagram

- Notes: 1) The coils are connected “in series” but the correct direction of current flow is chosen to ensure the right direction of beam deflection.
- 2) In the upper part of the diagram, lines entering a black circle represent wires connected at that point, but lines that cross each other at 90 degrees represent non-intersecting wires.

II. The Charge of the Electron

The classic method for measuring electron charge is described in the appendix (so you know what you’re missing), but we won’t be performing the measurement ourselves. The essence of the method is that small droplets of liquid may carry a net charge. By observing their motion in an electric field, the net charge can be deduced, and by observing many droplets, the smallest difference in charge between two droplets can be calculated. This smallest charge difference is the unit of charge, the charge of an electron.

For the purposes of changing your e/m value into a measurement of the electron mass, **let us assume you did a measurement of the electron charge, with the result of $1.71 \text{ E-19 Coulomb}$, with a fractional uncertainty of 5%.**

The Combined analysis

Using the best estimate for e/m (mean, std dev, sdm) from part I of the experiment and your best estimate of e from part II, compute the mass of the electron, m_e , and the uncertainty in the mass, δm_e . Indicate whether or not your measurement agrees with the known value.

The Write-up

Include tables and graphs where appropriate. Give a summary table including your final results for the charge and mass of the electron, including an error analysis. Compare with the given values and discuss discrepancies, if any.