

Experiment 8

Rotational Motion: Moment of Inertia

8.1 Objectives

- Familiarize yourself with the concept of moment of inertia, I , which plays the same role in the description of the rotation of a rigid body as mass plays in the description of linear motion.
- Investigate how changing the moment of inertia of a body affects its rotational motion.

8.2 Introduction

In physics, we encounter various types of motion, primarily linear or rotational. Today we will investigate rotational motion and measure one of the most important quantities pertaining to that: the moment of inertia. The way mass is distributed greatly affects how easily an object can rotate. For example, if you are sitting in a spinning office chair and extend your arms out away from your body, your rotation speed will slow down. If you then pull your arms back in as close as possible, you will start to rotate much faster than when your arms were extended. This illustrates that not only mass but also how it is distributed (i.e. moment of inertia) affects rotational motion.

8.3 Key Concepts

You can find a summary on-line at Hyperphysics.¹ Look for keywords: moment of inertia, torque, angular acceleration

8.4 Theory

If we apply a single unbalanced force, F , to an object, the object will undergo a linear acceleration, a , which is determined by the unbalanced force acting on the object and the mass, m , of the object. Newton's Second Law expresses this relationship:

$$F = ma$$

where the mass is a measure of an object's **inertia, or its resistance to being accelerated**.

In rotational motion, torque (represented by the Greek letter τ), is the rotational equivalent of force. Torque, roughly speaking, measures how effective a force is at causing an object to rotate about a pivot point. Torque, τ is defined as:

$$\tau = rF\sin(\theta) \tag{8.1}$$

where r is the lever arm, F is the force and θ is the angle between the force and the lever arm. In this lab the lever arm, r , will be the radius at which the force is applied (i.e. the radius of the axle). The force will be applied tangentially (i.e. perpendicular) to the radius so θ is 90° and $\sin(90^\circ) = 1$ making Eq. 8.1 become $\tau = rF$.

Newton's Second law applied to rotational motion says that a single unbalanced torque, τ , on an object produces an *angular* acceleration, α , which depends not only on the mass of the object but on how that mass is *distributed*, called the moment of inertia, I . The equation which is analogous to $F = ma$ for an object that is accelerating rotationally is

$$\tau = I\alpha \tag{8.2}$$

where the units of τ are in Newton-meters (N*m), α is in radians/sec² and I is in kg-m².²

¹<http://hyperphysics.phy-astr.gsu.edu/hbase/hph.html>

²A radian is an angle measure based upon the circumference of a circle $C = 2\pi r$ where r is the radius of the circle. A complete circle (360°) is said to have 2π radians. Therefore, a 1/4 circle (90°) is $\pi/2$ radians.

The moment of inertia, I , is a measure of the way the mass is distributed on the object and determines its resistance to angular acceleration. Every rigid object has a definite moment of inertia about a particular axis of rotation. The moment of inertia of a collection of masses is given by:

$$I = \sum m_i r_i^2 \quad (8.3)$$

If there is only one mass (as shown in Fig. 8.1) then Eq. 8.3 becomes $I = mr^2$. (In order to simplify the calculation we have assumed that the mass m is a point at the end of the lever arm r and the rod it is attached to is massless.) To illustrate, we will calculate the moment of inertia for a mass of 2 kg at the end of a massless rod that is 2 m in length:

$$I = mr^2 = (2 \text{ kg})(2 \text{ m})^2 = 8 \text{ kg m}^2$$

If a force of 5 N were applied to the mass *perpendicular* to the rod (to make the lever arm equal to r) the torque is given by:

$$\tau = rF = (2 \text{ m})(5 \text{ N}) = 10 \text{ N m}$$

By Eq. 8.2 we can now calculate the angular acceleration:

$$\alpha = \frac{\tau}{I} = \frac{10 \text{ N m}}{8 \text{ kg m}^2} = 1.25 \text{ rad/sec}^2$$

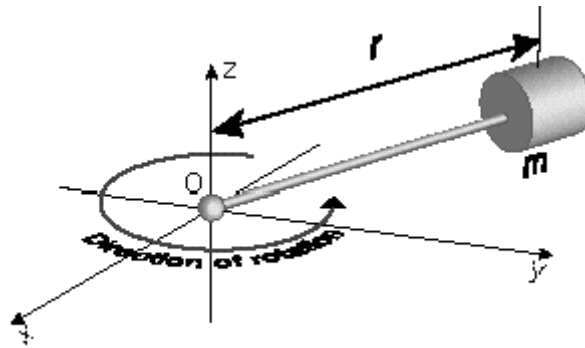

Figure 8.1: One point mass m on a massless rod of radius r ($I = mr^2$).

8. ROTATIONAL MOTION: MOMENT OF INERTIA

The moment of inertia of a more complicated object is found by adding up the moments of each individual piece. For example, the moment of inertia of the system shown in Fig. 8.2 is found by adding up the moments of each mass so Eq. 8.3 becomes $I = m_1r_1^2 + m_2r_2^2$. (Note that Fig. 8.2 is equivalent to the sum of two Fig. 8.1 components.)

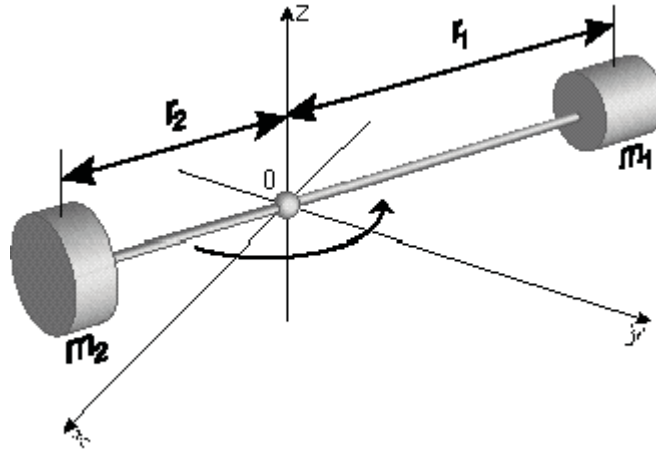

Figure 8.2: Two point masses on a massless rod ($I = m_1r_1^2 + m_2r_2^2$).

8.5 In today's lab

Today you will measure the moment of inertia for several different mass distributions. You will make a plot of the moment of inertia, I , vs. r^2 , the radii that your masses were placed at, and determine if the moment of inertia does indeed depend on both mass and its distribution. Your setup will resemble Fig. 8.2 where the rigid body consists of two cylinders, which are placed on a metallic rod at varying radii from the axis of rotation. You will assume the rod is massless and will place the masses, m_1 and m_2 , an equal distance from the center pivot point so that $r_1 = r_2 = r$. For this case Eq. 8.3 then becomes:

$$I = m_1r_1^2 + m_2r_2^2 = (m_1 + m_2)r^2 \quad (8.4)$$

A schematic of the equipment you will be using today is shown in Fig. 8.3. The masses and rod are supported by a rotating platform attached to a central pulley and nearly frictionless air bearings. If the two masses are placed on the axis of rotation (so $r = 0$), then the measured moment of inertia I is the moment of inertia of the rotating apparatus *alone* plus the moment of inertia of each of the two cylinders about an axis through their own centers of mass, which we'll call I_0 . So when the masses are placed at $r = 0$, $I = I_0$. Now if the two masses are each placed a distance r from the axis of rotation Eq. 8.4 becomes:

$$I = (m_1 + m_2)r^2 + I_0 \quad (8.5)$$

Compare Eq. 8.5 to the equation for a straight line:

$$y = mx + b$$

Notice that a plot of I vs. r^2 should be a straight line. The slope of this line is the sum of the masses ($m_1 + m_2$) and the y -intercept is I_0 .

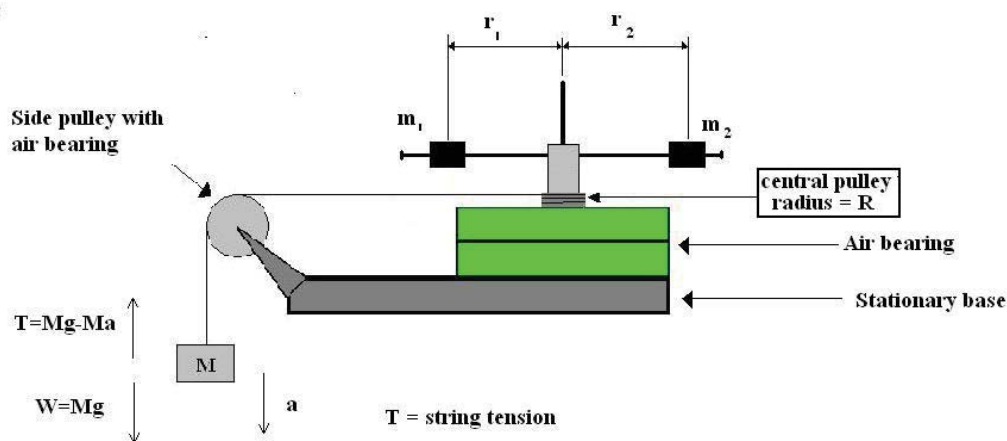

Figure 8.3: Schematic of the moment of inertia apparatus.

To verify that the moment of inertia, I , does indeed depend on how the masses are distributed you will use the apparatus shown in Fig. 8.3 to calculate the angular acceleration, α , and torque, τ , of the rotating masses and then use Eq. 8.2 to calculate I . You will plot your measured I vs. r^2

8. ROTATIONAL MOTION: MOMENT OF INERTIA

and check that your slope is consistent with your mass value ($m_1 + m_2$) thus verifying Eq. 8.5. The Excel spreadsheet requires several calculations to arrive at values for the angular acceleration and torque that are used to calculate the moment of inertia. The needed formulas are outlined below.

In order to get your rigid body to rotate you will wrap a string around the central axle (also called the central pulley) and run it over the side pulley to a known weight, M , as shown in Fig. 8.3. When you release the weight from rest just below the side pulley and let it fall to the floor, the tension, T , in the string will exert a torque, τ , on the rigid body causing it to rotate with a constant angular acceleration, α . **NOTE:** Be careful to not mix up the symbol for tension (T) with the symbol for torque (τ) and the symbol for linear acceleration (a) with the symbol for angular acceleration (α) in the following equations.

The angular acceleration (α) of your rigid body is related to the linear acceleration (a) of your falling mass by:

$$\alpha = \frac{\text{Linear acceleration}}{\text{Radius of axle}} = \frac{a}{R} \quad (8.6)$$

where R is the radius of the central axle at shown in Fig. 8.4.

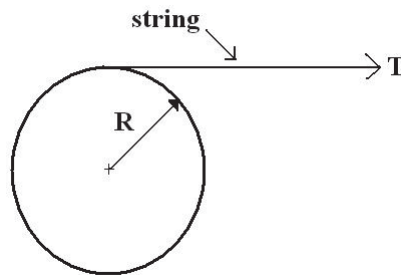

Figure 8.4: A top view of the central axle with radius R and the string providing the tension T .

You will use your knowledge of the equations of motion to find the linear acceleration a of the weight as it falls to the floor. Remember that the position, y , of an object released from rest ($v_i = 0$) with an initial position y_0 (in your case $y_0 = h$, the starting height h above the floor) is found using:

$$y = h - \frac{1}{2}at^2 \quad (8.7)$$

where the floor is defined to be at a height of $y = 0$. Since the final position of your mass will be the floor, $y = 0$, and Eq. 8.7 can be rearranged to find the linear acceleration, a :

$$a = \frac{2h}{t^2} \quad (8.8)$$

where t is the time it takes the weight to fall to the floor. Using your measured values for the time and height you can calculate the linear acceleration a which can then be used to calculate the angular acceleration α that will be used in Eq. 8.2.

Next you need to find the torque τ so you can calculate I using Eq. 8.2. Remember that torque was defined in Eq. 8.1 as the force applied times the lever arm when the force is applied tangentially:

$$\tau = rF \quad (8.9)$$

In this lab the force (F) comes from the tension (T) in the string that is acting perpendicular to the lever arm r , which here is the radius of the central axle (R), as shown in Fig. 8.4. So for this experiment Eq. 8.9 becomes:

$$\tau = R \times T \quad (8.10)$$

The tension in the string, T , comes from the weight which is hanging off the side pulley (see Fig. 8.3). By drawing the free-body diagram acting on the hanging mass and using Newton's Second Law, the tension in the string is:

$$T = Mg - Ma \quad (8.11)$$

where M is the amount of mass hanging below the side pulley, g is the acceleration due to gravity and a is the linear acceleration given in Eq. 8.8. Now you have all of the pieces to calculate the moment of inertia I of the rigid body using Eq. 8.2 ($I = \tau/\alpha$).

8.6 Equipment

- Two cylindrical masses
- Hanger with mass
- Air bearing with central pulley
- String

8.7 Procedure

In this experiment, you will change the moment of inertia of the rotating body by changing how the mass is distributed on the rotating body. You will place two cylindrical masses at four different radii, such that $r = r_1 = r_2$ in each case, on a metallic rod. You will then use your measurements to calculate the moment of inertia (I) for each of the four radial positions of the cylindrical masses (r). The sum of the two cylindrical masses ($m_1 + m_2$) can then be found from a graph of I versus r^2 .

1. Measure and record the masses of the hanging mass, M , and the two cylinders, m_1 and m_2 .
2. Place the cylinders on the horizontal rod such that the axes of the cylinders are along the horizontal rod as far away from the center as possible (as shown in Fig. 8.5). Make sure the thumbscrew on each cylinder is tightened. The center of mass of each cylinder MUST be the same distance (r) from the axis of rotation (i.e. $r_1 = r_2$ in Fig. 8.3).

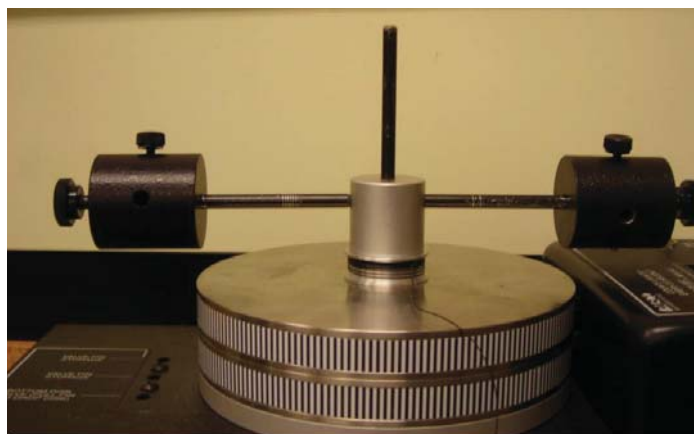

Figure 8.5: View of the apparatus with 2 masses at the same radius r .

3. Estimate the uncertainty in r (called δr). This should include both the uncertainty in reading your ruler and the uncertainty in locating the cylinder's center of mass.

4. With the air supply on, attach the hanging mass (M) to one end of a string and wind the other end around the central axle (pulley). The string should also pass over the side pulley such that the hanging mass is just below the side pulley as shown in Fig. 8.3. Hold the hanging mass stationary and measure its height (h) using the floor as your reference point. Record this elevation in your spreadsheet and assign an appropriate uncertainty to this measurement. **Make sure to return your mass to this same height for each of your trials.**
5. Release the hanging mass and simultaneously start the desktop timer. When the mass hits the floor, stop the timer and enter your value in the spreadsheet under t . For the uncertainty in this time (δt), use the standard deviation (denoted by s) from your reaction time which you measured in Lab #2 Reaction Time. (If you don't have your reaction time value then ask your TA for a reasonable value.)
6. Calculate the linear acceleration of the falling mass (M) using Eq. 8.8. Use $\delta a = a \left(2\frac{\delta t}{t} + \frac{\delta h}{h} \right)$ to calculate its uncertainty.
7. Use Eq. 8.11 to calculate the tension in the string (T) and $\delta T = T \left(\frac{\delta M}{M} + \frac{\delta a}{g-a} \right)$ to calculate its uncertainty.
8. Use Eq. 8.6 and the given radius of $R = 1.27 \pm 0.01$ cm for the central pulley to calculate the angular acceleration of the rotating apparatus. Use $\delta \alpha = \alpha \left(\frac{\delta a}{a} + \frac{\delta R}{R} \right)$ to calculate its uncertainty.
9. Use Eq. 8.10 to calculate the torque on the rotating apparatus and use $\delta \tau = \tau \left(\frac{\delta T}{T} + \frac{\delta R}{R} \right)$ to calculate its uncertainty. (**Note:** in this equation the Greek letter τ is the torque and T is the tension in the string.)
10. Use Eq. 8.2 to calculate the moment of inertia I of the rotating apparatus. Its uncertainty is given by $\delta I = I \left(\frac{\delta \tau}{\tau} + \frac{\delta \alpha}{\alpha} \right)$.
11. Calculate r^2 and its uncertainty, $\delta r^2 = 2r\delta r$.
12. Repeat the above steps for 2 additional, non-zero values of r . Make sure that the values of r for each trial differ by at least 2 cm.

8. ROTATIONAL MOTION: MOMENT OF INERTIA

- For the last trial you will place the two cylinders at $r = 0$. To do this, you will use the vertical bar on the support (see Fig. 8.6). When you place the cylinders on the vertical bar, make sure they are oriented the same way as in your previous trials, i.e. with the axes of the two cylinders perpendicular to the vertical bar. As before, make sure to tighten the thumbscrews on the cylinders. Follow the above procedure to calculate the moment of inertia of the body with the two cylinders at $r = 0$. Include this data in your data table.



Figure 8.6: View of apparatus with 2 masses at radius $r = 0$.

- Transfer your data into KaleidaGraph and make a plot of I vs. r^2 . Your data points should have both horizontal and vertical error bars. Fit your data with a best fit line making sure to display the fit values for slope and y -intercept with their uncertainties.

8.8 Checklist

- Excel spreadsheets (both data and formula views)
- Plot of I vs. r^2 with both horizontal and vertical error bars, a best fit line and observations.
- Answers to questions

8.9 Questions

1. The moment of inertia of a body depends not only on its mass, but also on how the mass is distributed. Does your data support this? Why or why not?

2. In your plot of I vs. r^2 , why did you use r^2 and not r in the plot? What are the units of the slope of I vs. r^2 ?

8. ROTATIONAL MOTION: MOMENT OF INERTIA

3. Discuss the consistency of the slope of the plot of I vs. r^2 with the value you measured for $(m_1 + m_2)$. If they are not consistent, suggest possible reasons why. The uncertainty in your measured mass is given by:
- $$\delta(m_1 + m_2) = \delta(m_1) + \delta(m_2)$$

4. In the procedure, you were given that $R = 1.27 \pm 0.01$ cm. Using only the experimental apparatus and a meter stick, how would you verify this radius with an uncertainty of less than or equal to 0.01 cm?
(**Hint:** You cannot get this uncertainty by holding the meter stick next to the axle and measuring the diameter. Also note that the string is a part of the apparatus.)

	A	B	C	D	E	F	G	H	I	J	K	L	M	N
1	<i>Moment of Inertia</i>													
2														
3														
4	Measure grey fields			Calculate yellow fields			Use standard deviation from exp. 2							
5														
6					Value	Uncertainty	Units							
7	Rotating mass m_1 :						gm							
8	Rotating mass m_2 :						gm							
9	Falling mass M :						gm							
10	Radius of axle R :				1.270	0.01	cm							
11	Gravitational acceleration g :				980		cm/sec^2							
12	Starting elevation of M h :						cm							
13	Uncertainty in time						sec							
14														
15	Determination of the moment of inertia													
16														
17	Mount the masses on the rod and measure the time it takes the mass M to fall to the floor for 4 different positions of the masses along the rod. Calculate the linear acceleration a , the angular acceleration α , the tension in the string, the torque and the moment of inertia (I) and their associated uncertainties for each configuration from the angular acceleration using equation using equations 1 through 4 in the tables below													
18														
19														
20														
21														
22														
23	Trial	r	δr	t	a	δa	T	δT	α	$\delta \alpha$	Torque	$\delta(Torque)$		
24		cm	cm	sec	cm/sec^2	cm/sec^2	dyne	dyne	rad/sec^2	rad/sec^2	dyne-cm	dyne-cm		
25	1													
26	2													
27	3													
28	4	0.00												
29														
30														
31		Trial	r^2	δr^2	I	δI								
32			cm^2	cm^2	$gm \cdot cm^2$	$gm \cdot cm^2$								
33		1												
34		2												
35		3												
36		4	0.00	0.00										
37														
38														