

## *Experiment 10*

---

# **Heat Equivalent of Mechanical Energy**

---

### **10.1 Objectives**

- Observe the conversion of mechanical energy into heat.
- Learn how to convert the units traditionally used to measure heat (calories) into the units appropriate to mechanical energy (joules).

### **10.2 Introduction**

In the previous labs, we have been using friction as a reason for energy loss, but how does that happen? When you have friction on an object, the object begins to heat up. You can try this by simply rubbing your hands together really quickly. You can feel your hands heat up due to the motion you are imparting by rubbing them together! The exact same thing happens with everything else in nature. Whenever something is in contact with something else and they are moving relative to each other, the friction between the two objects will heat them up, and without any external forces, the objects will lose energy.

### 10.3 Key Concepts

As always, you can find a summary on-line at Hyperphysics.<sup>1</sup> Look for keywords: heat, specific heat, heat transfer

### 10.4 Theory

In your physics course on mechanics, you saw the **Law of Conservation of Mechanical Energy** expressed this way:

$$\text{Work Done on a System} = \Delta\text{PE} + \Delta\text{KE} \quad (10.1)$$

where KE is **kinetic energy** and PE is **potential energy**. If there are frictional forces present, we can divide up the total work done on the system into the work done by external forces and the work done by friction:

$$\text{External Work} + \text{Friction Work} = \Delta\text{PE} + \Delta\text{KE} \quad (10.2)$$

Remember that **Friction Work** is negative, because the frictional force on a moving object always points in the direction *opposite* to the direction of motion.

There is another way to think about friction. Instead of treating the friction as an external force that does work on the system, we can expand our definition of the system to include the source of friction. (For example, if our original system were a block sliding across the floor, our new system would be the block *and* the floor together.) Then we have to recognize that the energy in the system may be converted from mechanical energy into other forms of energy, such as heat or thermal energy. From this more general point of view, the **Law of Conservation of Energy** takes this form:

$$\text{External Work} = \Delta\text{PE} + \Delta\text{KE} + \Delta(\text{Thermal Energy}) \quad (10.3)$$

Comparing Eqs. 10.2 and 10.3 leads us to the conclusion that

$$-\text{Friction Work} = \Delta(\text{Thermal Energy}) \quad (10.4)$$

---

<sup>1</sup><http://hyperphysics.phy-astr.gsu.edu/hbase/hph.html>

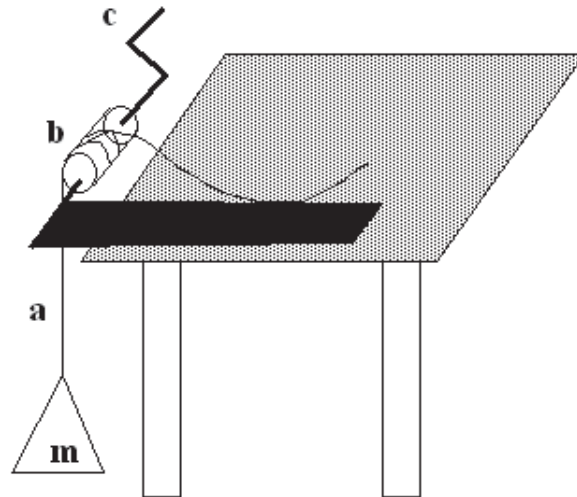
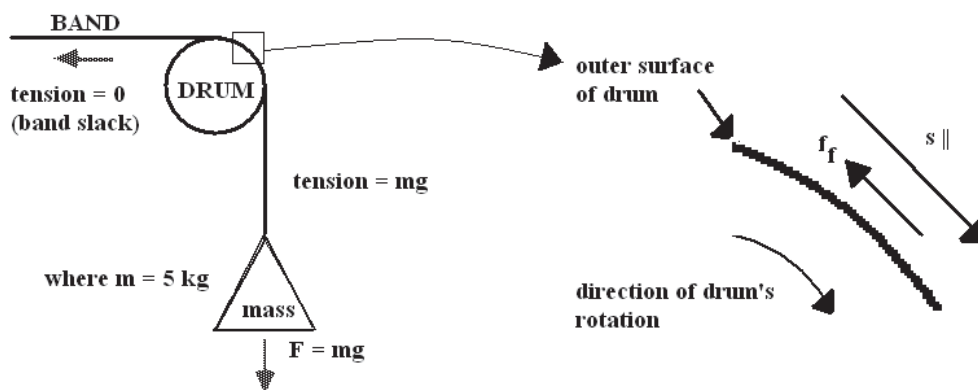

Figure 10.1: Schematic of the apparatus.

Remember that Friction Work is negative, so both sides of this equation are positive. Equation 10.4 says that the loss in mechanical energy due to friction equals the gain in thermal energy of the system. Equation 10.4 is the relation you will test in this Lab.

A nylon rope (a) is wrapped around an aluminum drum (b) and is held by hand at one end. At the other end of the band dangles a 5 kg mass (m). The aluminum drum is turned beneath the rope by means of a crank (c) turned by a student, and the 5 kg mass remains stationary. As the drum turns it rubs against the band, and the resulting friction generates heat, which causes the temperature of the band and of the drum to rise. The rise in temperature is a measure of the heat energy generated. To test equation 10.4 we must calculate the **friction work**, measure the **change in heat energy**, and see whether they are *equal*. We will now discuss how this can be done.

You may be wondering, “Where did the thermal energy come from?” It didn’t just appear magically. Going back to Equation 10.2 or 10.3, you can see that it comes from the external work that you do by turning the crank. In fact, in this experiment the block starts and ends in the same place, so  $\Delta PE = \Delta KE = 0$ , and the work you do should be exactly equal

Figure 10.2: Diagram of  $f_f$  and  $s_{||}$ .

to the increase in thermal energy. But it is hard to measure the work you do. It is much easier to measure the work done by friction, as we show below.

### Work Done by Friction

Friction work is given by the equation

$$\text{Friction Work} = -f_f s_{||} \quad (10.5)$$

where  $f_f$  is the force of friction, and  $s_{||}$  is the distance parallel to  $f_f$  over which the force of friction acts. The work done by friction is negative because  $f_f$  always points in the direction opposite to the direction of motion of the body. To see what  $f_f$  and  $s_{||}$  are, we refer to Fig. 10.2.

We see in Figure 10.2 that the 5 kg mass is being pulled down by gravity with a force  $mg$ , with  $m = 5$  kg. Since the mass isn't accelerating, the rope must be pulling up on it with the same force. So the **tension** in the vertical part of the rope is equal to  $mg$ . The other end of the rope, however, is slack. How did that happen? The frictional force between the drum and the rope must exactly equal  $mg$ , because that is the difference in tension of the vertical and horizontal sections of the rope. That frictional force is distributed along the whole length of the rope that is wrapped around the drum 4 or 5 times. The distance  $s_{||}$  is the total distance the outer edge of the drum moves against the rope. That is equal to the **circumference of**

the drum,  $c_D$ , times the **number of times the crank is turned**,  $n$ . So we have  $s_{\parallel} = nc_D$ . Putting all this together, we get:

$$\text{Friction Work} = -(mg)(nc_D) \quad (10.6)$$

### Change in Heat Energy

When heat is added to a system, it causes the temperature of the system to rise. The heat energy added,  $\Delta H$ , is related to the temperature rise,  $\Delta T$ , by the equation:

$$\Delta H = CM(\Delta T) \quad (10.7)$$

where  $C$  is the **specific heat capacity** of the system and  $M$  is the **mass** of the system. To calculate  $\Delta H$  you need to know  $C$  and you need to measure  $M$  and  $\Delta T$ .

Although heat is just another form of energy, and can therefore be measured in Joules, for historical reasons it is measured in terms of different units, called calories. One calorie is defined as the amount of heat needed to raise the temperature of *one gram of water by one degree Celsius*. The conversion factor between calories and joules is:

$$1 \text{ calorie} = 4.18 \text{ joules} \quad (10.8)$$

In the present experiment,  $C$  is made up of contributions from two different components, the aluminum drum and the nylon rope. We will neglect the heating of the rope. The heat capacity is given by the product of the mass of the component times the *specific heat capacity* of the material of which the component is composed. Water has a specific heat capacity of  $1 \text{ cal/g}^\circ \text{C}$  and aluminum has a specific heat capacity of  $0.215 \text{ cal/g}^\circ \text{C}$ . The contribution of the drum is  $(0.215 \text{ cal/g}^\circ \text{C}) M_D$  where  $M_D$  is the mass of the drum. The nylon band has negligible heat capacity. With these values, equation 10.6 takes the form:

$$\Delta H(\text{in calories}) = [0.215M_D]\Delta T \quad (10.9)$$

If all the mechanical work goes into heat, then using equation 10.8,

$$|\Delta W| = 4.18\Delta H \quad (10.10)$$

This is the relationship we will test in this experiment.

## 10.5 In today's lab

Today we will cool down an aluminium drum to  $3^{\circ}$  C below room temperature. We will then attempt to use friction to heat the drum to  $3^{\circ}$  above room temperature using a calculated number of cranks. Finally, we will see if our calculation was correct using a consistency check.

## 10.6 Equipment

- Aluminum Drum
- Nylon Rope
- Thermocouple
- 5 kg Hanging Mass
- Crank
- Calipers

## 10.7 Procedure

1. Determine the mass of the aluminum drum and record it in your spreadsheet.
2. Using the thermocouple, determine the room temperature by inserting the probe into the heat measurement hole of the drum. Do this by setting the thermocouple to mV and by pressing the yellow button to set it to Celsius. Record this in your spreadsheet.
3. Measure the circumference,  $c_D$ , of the aluminum drum using the vernier calipers. Record this in your spreadsheet.
4. To compensate for heat loss during the experiment, we will cool the drum in the refrigerator. Carefully remove the aluminum drum from the crank and place it in the refrigerator until it is at least  $3^{\circ}$  C below room temperature.

5. While the drum is cooling, calculate the number of cranks needed to raise the drum's temperature by  $6^\circ\text{C}$  using equations 10.6, 10.9 and 10.10.
6. When the drum is sufficiently cooled, place it back onto your crank and be sure to lock it down securely, making sure that the pin on the crank lines up with the slot on the cylinder.
7. Wrap the nylon string around the drum 4 or 5 times, and have one partner elevate the 5 kg mass off approximately 2–3 inches off of the ground. Be sure that they hold on to the loose end of the string to help support the weight. Please make sure your feet are not under the 5 kg mass.
8. When the drum is exactly  $3^\circ\text{C}$  below room temperature, begin cranking the crank the designated number of times that you calculated. Be sure to crank fast enough that the 5 kg mass remains suspended in the air without additional force. The partner holding the loose end of the string can easily adjust the height of the mass while the crank is being turned by pulling on or loosening the string.
9. After cranking the designated number of times, measure the final temperature of the drum and record it in excel.
10. Calculate  $\Delta W$  (the Friction Work) and  $\Delta H$  (the change in Heat Energy in calories). Use Eq. 10.10 to convert from calories to Joules. Compare the change in Heat Energy to the work done (the formulae for the uncertainties are in the excel spreadsheet for this lab).

## 10.8 Checklist

1. Excel Sheets
2. Sample Calculations
3. Questions







## 10. HEAT EQUIVALENT OF MECHANICAL ENERGY

---

3. The available energy contents of various kinds of food are often listed in “Calories” charts. One of these food “Calories” is actually 1000 calories of the type defined in this experiment, i.e. 1 food Calorie = 1 kcal or kilocalorie. Assuming the human body is 50% efficient in the conversion of food Calories into mechanical work, how many turns of the crank would have been necessary to work off an average breakfast of about 600 food Calories? An efficiency of 50% means that only 50% of the food energy intake can be used for mechanical work. The other 50% is wasted in the form of heat (sweating).

## *Experiment 10*

---

# **Heat Equivalent of Mechanical Energy**

---

### **10.1 Objectives**

- Observe the conversion of mechanical energy into heat.
- Learn how to convert the units traditionally used to measure heat (calories) into the units appropriate to mechanical energy (joules).

### **10.2 Introduction**

In the previous labs, we have been using friction as a reason for energy loss, but how does that happen? When you have friction on an object, the object begins to heat up. You can try this by simply rubbing your hands together really quickly. You can feel your hands heat up due to the motion you are imparting by rubbing them together! The exact same thing happens with everything else in nature. Whenever something is in contact with something else and they are moving relative to each other, the friction between the two objects will heat them up, and without any external forces, the objects will lose energy.

### 10.3 Key Concepts

As always, you can find a summary on-line at Hyperphysics.<sup>1</sup> Look for keywords: heat, specific heat, heat transfer

### 10.4 Theory

In your physics course on mechanics, you saw the **Law of Conservation of Mechanical Energy** expressed this way:

$$\text{Work Done on a System} = \Delta\text{PE} + \Delta\text{KE} \quad (10.1)$$

where KE is **kinetic energy** and PE is **potential energy**. If there are frictional forces present, we can divide up the total work done on the system into the work done by external forces and the work done by friction:

$$\text{External Work} + \text{Friction Work} = \Delta\text{PE} + \Delta\text{KE} \quad (10.2)$$

Remember that **Friction Work** is negative, because the frictional force on a moving object always points in the direction *opposite* to the direction of motion.

There is another way to think about friction. Instead of treating the friction as an external force that does work on the system, we can expand our definition of the system to include the source of friction. (For example, if our original system were a block sliding across the floor, our new system would be the block *and* the floor together.) Then we have to recognize that the energy in the system may be converted from mechanical energy into other forms of energy, such as heat or thermal energy. From this more general point of view, the **Law of Conservation of Energy** takes this form:

$$\text{External Work} = \Delta\text{PE} + \Delta\text{KE} + \Delta(\text{Thermal Energy}) \quad (10.3)$$

Comparing Eqs. 10.2 and 10.3 leads us to the conclusion that

$$-\text{Friction Work} = \Delta(\text{Thermal Energy}) \quad (10.4)$$

---

<sup>1</sup><http://hyperphysics.phy-astr.gsu.edu/hbase/hph.html>

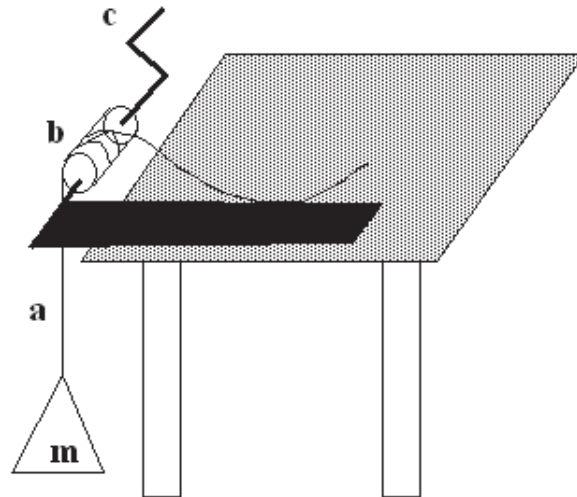
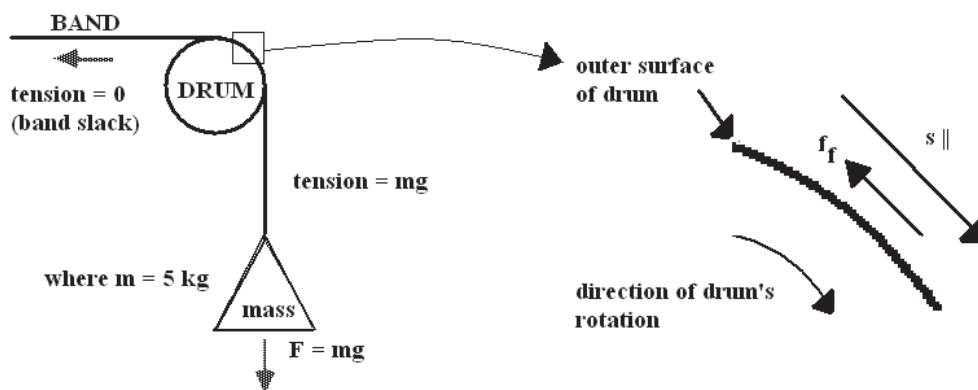

Figure 10.1: Schematic of the apparatus.

Remember that Friction Work is negative, so both sides of this equation are positive. Equation 10.4 says that the loss in mechanical energy due to friction equals the gain in thermal energy of the system. Equation 10.4 is the relation you will test in this Lab.

A nylon rope (a) is wrapped around an aluminum drum (b) and is held by hand at one end. At the other end of the band dangles a 5 kg mass (m). The aluminum drum is turned beneath the rope by means of a crank (c) turned by a student, and the 5 kg mass remains stationary. As the drum turns it rubs against the band, and the resulting friction generates heat, which causes the temperature of the band and of the drum to rise. The rise in temperature is a measure of the heat energy generated. To test equation 10.4 we must calculate the **friction work**, measure the **change in heat energy**, and see whether they are *equal*. We will now discuss how this can be done.

You may be wondering, “Where did the thermal energy come from?” It didn’t just appear magically. Going back to Equation 10.2 or 10.3, you can see that it comes from the external work that you do by turning the crank. In fact, in this experiment the block starts and ends in the same place, so  $\Delta PE = \Delta KE = 0$ , and the work you do should be exactly equal

Figure 10.2: Diagram of  $f_f$  and  $s_{\parallel}$ .

to the increase in thermal energy. But it is hard to measure the work you do. It is much easier to measure the work done by friction, as we show below.

### Work Done by Friction

Friction work is given by the equation

$$\text{Friction Work} = -f_f s_{\parallel} \quad (10.5)$$

where  $f_f$  is the force of friction, and  $s_{\parallel}$  is the distance parallel to  $f_f$  over which the force of friction acts. The work done by friction is negative because  $f_f$  always points in the direction opposite to the direction of motion of the body. To see what  $f_f$  and  $s_{\parallel}$  are, we refer to Fig. 10.2.

We see in Figure 10.2 that the 5 kg mass is being pulled down by gravity with a force  $mg$ , with  $m = 5$  kg. Since the mass isn't accelerating, the rope must be pulling up on it with the same force. So the **tension** in the vertical part of the rope is equal to  $mg$ . The other end of the rope, however, is slack. How did that happen? The frictional force between the drum and the rope must exactly equal  $mg$ , because that is the difference in tension of the vertical and horizontal sections of the rope. That frictional force is distributed along the whole length of the rope that is wrapped around the drum 4 or 5 times. The distance  $s_{\parallel}$  is the total distance the outer edge of the drum moves against the rope. That is equal to the **circumference of**

the drum,  $c_D$ , times the **number of times the crank is turned**,  $n$ . So we have  $s_{||} = nc_D$ . Putting all this together, we get:

$$\text{Friction Work} = -(mg)(nc_D) \quad (10.6)$$

### Change in Heat Energy

When heat is added to a system, it causes the temperature of the system to rise. The heat energy added,  $\Delta H$ , is related to the temperature rise,  $\Delta T$ , by the equation:

$$\Delta H = CM(\Delta T) \quad (10.7)$$

where  $C$  is the **specific heat capacity** of the system and  $M$  is the **mass** of the system. To calculate  $\Delta H$  you need to know  $C$  and you need to measure  $M$  and  $\Delta T$ .

Although heat is just another form of energy, and can therefore be measured in Joules, for historical reasons it is measured in terms of different units, called calories. One calorie is defined as the amount of heat needed to raise the temperature of *one gram of water by one degree Celsius*. The conversion factor between calories and joules is:

$$1 \text{ calorie} = 4.18 \text{ joules} \quad (10.8)$$

In the present experiment,  $C$  is made up of contributions from two different components, the aluminum drum and the nylon rope. We will neglect the heating of the rope. The heat capacity is given by the product of the mass of the component times the *specific heat capacity* of the material of which the component is composed. Water has a specific heat capacity of  $1 \text{ cal/g}^\circ \text{C}$  and aluminum has a specific heat capacity of  $0.215 \text{ cal/g}^\circ \text{C}$ . The contribution of the drum is  $(0.215 \text{ cal/g}^\circ \text{C}) M_D$  where  $M_D$  is the mass of the drum. The nylon band has negligible heat capacity. With these values, equation 10.6 takes the form:

$$\Delta H(\text{in calories}) = [0.215M_D]\Delta T \quad (10.9)$$

If all the mechanical work goes into heat, then using equation 10.8,

$$|\Delta W| = 4.18\Delta H \quad (10.10)$$

This is the relationship we will test in this experiment.

## 10.5 In today's lab

Today we will cool down an aluminium drum to  $3^{\circ}$  C below room temperature. We will then attempt to use friction to heat the drum to  $3^{\circ}$  above room temperature using a calculated number of cranks. Finally, we will see if our calculation was correct using a consistency check.

## 10.6 Equipment

- Aluminum Drum
- Nylon Rope
- Thermocouple
- 5 kg Hanging Mass
- Crank
- Calipers

## 10.7 Procedure

1. Determine the mass of the aluminum drum and record it in your spreadsheet.
2. Using the thermocouple, determine the room temperature by inserting the probe into the heat measurement hole of the drum. Do this by setting the thermocouple to mV and by pressing the yellow button to set it to Celsius. Record this in your spreadsheet.
3. Measure the circumference,  $c_D$ , of the aluminum drum using the vernier calipers. Record this in your spreadsheet.
4. To compensate for heat loss during the experiment, we will cool the drum in the refrigerator. Carefully remove the aluminum drum from the crank and place it in the refrigerator until it is at least  $3^{\circ}$  C below room temperature.



5. While the drum is cooling, calculate the number of cranks needed to raise the drum's temperature by  $6^\circ\text{C}$  using equations 10.6, 10.9 and 10.10.
6. When the drum is sufficiently cooled, place it back onto your crank and be sure to lock it down securely, making sure that the pin on the crank lines up with the slot on the cylinder.
7. Wrap the nylon string around the drum 4 or 5 times, and have one partner elevate the 5 kg mass off approximately 2–3 inches off of the ground. Be sure that they hold on to the loose end of the string to help support the weight. Please make sure your feet are not under the 5 kg mass.
8. When the drum is exactly  $3^\circ\text{C}$  below room temperature, begin cranking the crank the designated number of times that you calculated. Be sure to crank fast enough that the 5 kg mass remains suspended in the air without additional force. The partner holding the loose end of the string can easily adjust the height of the mass while the crank is being turned by pulling on or loosening the string.
9. After cranking the designated number of times, measure the final temperature of the drum and record it in excel.
10. Calculate  $\Delta W$  (the Friction Work) and  $\Delta H$  (the change in Heat Energy in calories). Use Eq. 10.10 to convert from calories to Joules. Compare the change in Heat Energy to the work done (the formulae for the uncertainties are in the excel spreadsheet for this lab).

## 10.8 Checklist

1. Excel Sheets
2. Sample Calculations
3. Questions





## 10. HEAT EQUIVALENT OF MECHANICAL ENERGY

---

3. The available energy contents of various kinds of food are often listed in “Calories” charts. One of these food “Calories” is actually 1000 calories of the type defined in this experiment, i.e. 1 food Calorie = 1 kcal or kilocalorie. Assuming the human body is 50% efficient in the conversion of food Calories into mechanical work, how many turns of the crank would have been necessary to work off an average breakfast of about 600 food Calories? An efficiency of 50% means that only 50% of the food energy intake can be used for mechanical work. The other 50% is wasted in the form of heat (sweating).

	A	B	C	D	E	F	G	H	I
1	<b><i>Heat Equivalent of Mechanical Energy</i></b>								
2									
3									
4	Measured								
5	Calculated								
6				<b>Value</b>			<b>Errors</b>	<b>Units</b>	
								<b>fill in</b>	
7	Diameter of drum	D=	<input type="text"/>		$\delta D=$	<input type="text"/>	<input type="text"/>	<input type="text"/>	
8	Circumference of drum	$C_d=$	<input type="text"/>		$\delta C_d=$	<input type="text"/>	<input type="text"/>	<input type="text"/>	
9	Mass of calorimeter/drum	$M_D=$	<input type="text"/>		$\delta M_D=$	<input type="text"/>	<input type="text"/>	<input type="text"/>	
10	Suspended mass	m=	<input type="text"/>		$\delta m=$	<input type="text"/>	<input type="text"/>	<input type="text"/>	
11									
12									
13	Calculated number of turns to use	n=	<input type="text"/>						
14									
15	Room temperature	$T_{room}$	<input type="text"/>						
16									
17	Starting temperature	$T_1=$	<input type="text"/>		$\delta T_1=$	<input type="text"/>	<input type="text"/>	<input type="text"/>	
18	Final temperature	$T_2=$	<input type="text"/>		$\delta T_2=$	<input type="text"/>	<input type="text"/>	<input type="text"/>	
19									
20	Temperature difference	$\Delta T=$	<input type="text"/>		$\delta \Delta T=$	<input type="text"/>	<input type="text"/>	<input type="text"/>	
21									
22									
23									
24	Friction Work	$ \Delta W =$	<input type="text"/>		$\delta \Delta W=$	<input type="text"/>	<input type="text"/>	Joules	
25	Heat energy	$\Delta H=$	<input type="text"/>		$\delta \Delta H=$	<input type="text"/>	<input type="text"/>	calories	
26	Heat energy	$\Delta H=$	<input type="text"/>		$\delta \Delta H=$	<input type="text"/>	<input type="text"/>	Joules	
27									
28	Summary of errors:								
29	$\delta C_d = \pi * \delta D$		$\delta(\Delta T) = \delta T_1 + \delta T_2$						
30									
31	$\delta(\Delta W) = \Delta W * \{ \delta m/m + \delta C_d/C_d \}$								
32	$\delta(\Delta H) = \Delta H * \{ \delta M/M + \delta \Delta T/\Delta T \}$								
33									
34									