

FPT-100P-M06

<p>100-pin plastic QFP</p>  <p>(FPT-100P-M06)</p>	Lead pitch	0.65 mm
	Package width × package length	14.00 × 20.00 mm
	Lead shape	Gullwing
	Sealing method	Plastic mold
	Mounting height	3.35 mm MAX
	Code (Reference)	P-QFP100-14×20-0.65

100-pin plastic QFP  
(FPT-100P-M06)

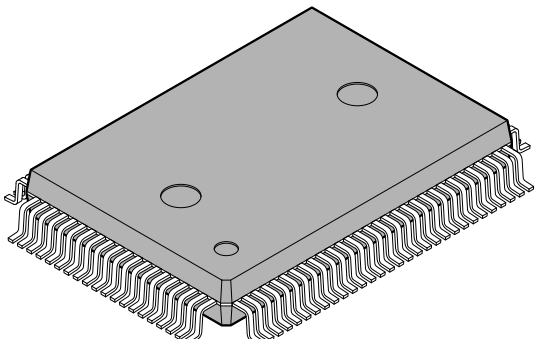
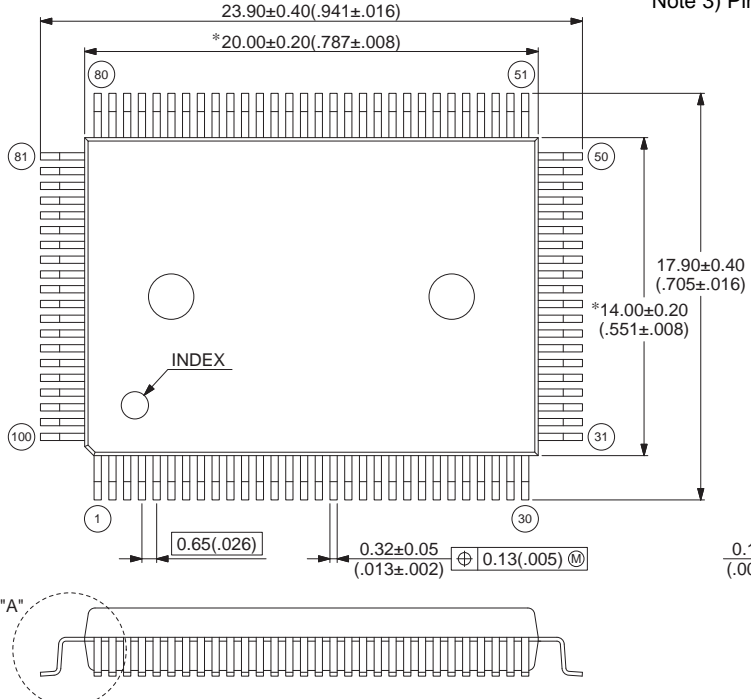

Note 1) \* : These dimensions do not include resin protrusion.  
 Note 2) Pins width and pins thickness include plating thickness.  
 Note 3) Pins width do not include tie bar cutting remainder.

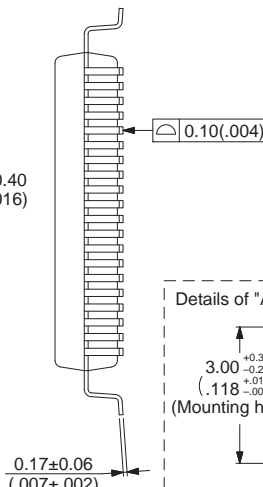

Details of "A" part

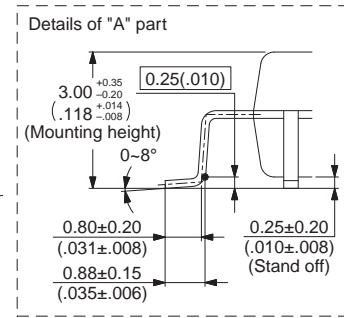

© 2002-2010 FUJITSU SEMICONDUCTOR LIMITED F100008S-c-5-7

Dimensions in mm (inches).  
Note: The values in parentheses are reference values.

The contents of this document are subject to change without notice.  
 Customers are advised to consult with FUJITSU SEMICONDUCTOR sales representatives before ordering.  
 FUJITSU SEMICONDUCTOR is unable to assume responsibility for infringement of any patent rights or other rights of third parties arising from the use of the information or package dimensions in this document.