

DS90LV031A

3V LVDS Quad CMOS Differential Line Driver

General Description

The DS90LV031A is a quad CMOS differential line driver designed for applications requiring ultra low power dissipation and high data rates. The device is designed to support data rates in excess of 400 Mbps (200 MHz) utilizing Low Voltage Differential Signaling (LVDS) technology.

The DS90LV031A accepts low voltage LVTTTL/LVCMOS input levels and translates them to low voltage (350 mV) differential output signals. In addition the driver supports a TRI-STATE® function that may be used to disable the output stage, disabling the load current, and thus dropping the device to an ultra low idle power state of 13 mW typical.

The EN and EN* inputs allow active Low or active High control of the TRI-STATE outputs. The enables are common to all four drivers. The DS90LV031A and companion line receiver (DS90LV032A) provide a new alternative to high power psuedo-ECL devices for high speed point-to-point interface applications.

Features

- >400 Mbps (200 MHz) switching rates
- 0.1 ns typical differential skew
- 0.4 ns maximum differential skew
- 2.0 ns maximum propagation delay
- 3.3V power supply design
- ±350 mV differential signaling
- Low power dissipation (13mW at 3.3V static)
- Interoperable with existing 5V LVDS devices
- Compatible with IEEE 1596.3 SCI LVDS standard
- Compatible with TIA/EIA-644 LVDS standard
- Industrial operating temperature range
- Available in SOIC and TSSOP surface mount packaging

Connection Diagram

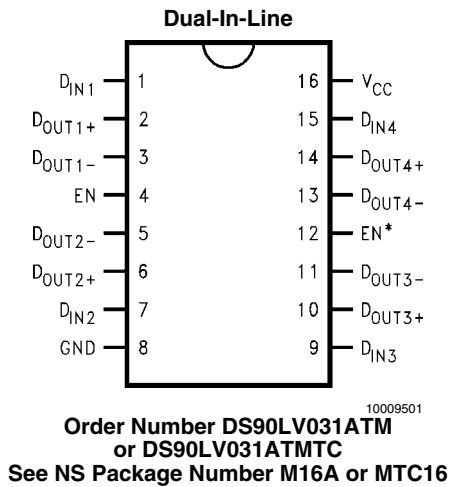

Functional Diagram

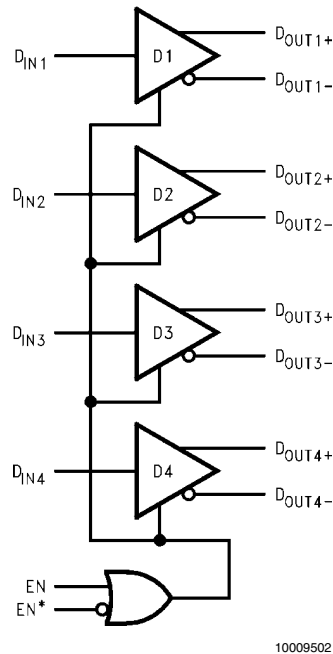

Truth Table

Enables		Input	Outputs	
EN	EN*	D _{IN}	D _{OUT+}	D _{OUT-}
L	H	X	Z	Z
All other combinations of ENABLE inputs		L	L	H
		H	H	L

TRI-STATE® is a registered trademark of National Semiconductor Corporation.

Absolute Maximum Ratings *(Note 1)*

If Military/Aerospace specified devices are required, please contact the National Semiconductor Sales Office/ Distributors for availability and specifications.

Supply Voltage (V_{CC})	-0.3V to +4V
Input Voltage (D_{IN})	-0.3V to ($V_{CC} + 0.3V$)
Enable Input Voltage (EN, EN*)	-0.3V to ($V_{CC} + 0.3V$)
Output Voltage (D_{OUT+} , D_{OUT-})	-0.3V to +3.9V
Short Circuit Duration (D_{OUT+} , D_{OUT-})	Continuous
Maximum Package Power Dissipation @ +25°C	
M Package	1088 mW
MTC Package	866 mW
Derate M Package	8.5 mW/°C above +25°C
Derate MTC Package	6.9 mW/°C above +25°C

Storage Temperature Range	-65°C to +150°C
Lead Temperature Range Soldering (4 sec.)	+260°C
Maximum Junction Temperature	+150°C
ESD Rating <i>(Note 10)</i> (HBM, 1.5 kΩ, 100 pF)	≥ 6 kV

Recommended Operating Conditions

	Min	Typ	Max	Units
Supply Voltage (V_{CC})	+3.0	+3.3	+3.6	V
Operating Free Air Temperature (T_A)				
Industrial	-40	+25	+85	°C

Electrical Characteristics

Over supply voltage and operating temperature ranges, unless otherwise specified. *(Note 2, Note 3, Note 4)*

Symbol	Parameter	Conditions	Pin	Min	Typ	Max	Units
V_{OD1}	Differential Output Voltage	$R_L = 100\Omega$ <i>(Figure 1)</i>	D_{OUT-} D_{OUT+}	250	350	450	mV
ΔV_{OD1}	Change in Magnitude of V_{OD1} for Complementary Output States				4	35	lmVl
V_{OS}	Offset Voltage			1.125	1.25	1.375	V
ΔV_{OS}	Change in Magnitude of V_{OS} for Complementary Output States				5	25	lmVl
V_{OH}	Output Voltage High				1.38	1.6	V
V_{OL}	Output Voltage Low			0.90	1.03		V
V_{IH}	Input Voltage High		D_{IN} , EN, EN*	2.0		V_{CC}	V
V_{IL}	Input Voltage Low			GND		0.8	V
I_{IH}	Input Current	$V_{IN} = V_{CC}$ or 2.5V		-10	±1	+10	µA
I_{IL}	Input Current	$V_{IN} = GND$ or 0.4V		-10	±1	+10	µA
V_{CL}	Input Clamp Voltage	$I_{CL} = -18$ mA		-1.5	-0.8		V
I_{OS}	Output Short Circuit Current	ENABLED, <i>(Note 11)</i> $D_{IN} = V_{CC}$, $D_{OUT+} = 0V$ or $D_{IN} = GND$, $D_{OUT-} = 0V$	D_{OUT-} D_{OUT+}		-6.0	-9.0	mA
I_{OSD}	Differential Output Short Circuit Current	ENABLED, $V_{OD} = 0V$ <i>(Note 11)</i>			-6.0	-9.0	mA
I_{OFF}	Power-off Leakage	$V_{OUT} = 0V$ or 3.6V, $V_{CC} = 0V$ or Open		-20	±1	+20	µA
I_{OZ}	Output TRI-STATE Current	EN = 0.8V and EN* = 2.0V $V_{OUT} = 0V$ or V_{CC}		-10	±1	+10	µA
I_{CC}	No Load Supply Current Drivers Enabled	$D_{IN} = V_{CC}$ or GND	V_{CC}		5.0	8.0	mA
I_{CCL}	Loaded Supply Current Drivers Enabled	$R_L = 100\Omega$ All Channels, $D_{IN} = V_{CC}$ or GND (all inputs)			23	30	mA
I_{CCZ}	No Load Supply Current Drivers Disabled	$D_{IN} = V_{CC}$ or GND, EN = GND, EN* = V_{CC}			2.6	6.0	mA

Switching Characteristics - Industrial

$V_{CC} = +3.3V \pm 10\%$, $T_A = -40^\circ C$ to $+85^\circ C$ (Note 3, Note 9, Note 12)

Symbol	Parameter	Conditions	Min	Typ	Max	Units
t_{PHLD}	Differential Propagation Delay High to Low	$R_L = 100\Omega$, $C_L = 10$ pF (Figure 2 and Figure 3)	0.8	1.18	2.0	ns
t_{PLHD}	Differential Propagation Delay Low to High		0.8	1.25	2.0	ns
t_{SKD1}	Differential Pulse Skew $ t_{PHLD} - t_{PLHD} $ (Note 5)		0	0.07	0.4	ns
t_{SKD2}	Channel-to-Channel Skew (Note 6)		0	0.1	0.5	ns
t_{SKD3}	Differential Part to Part Skew (Note 7)		0		1.0	ns
t_{SKD4}	Differential Part to Part Skew (Note 8)		0		1.2	ns
t_{TLH}	Rise Time			0.38	1.5	ns
t_{THL}	Fall Time			0.40	1.5	ns
t_{PHZ}	Disable Time High to Z	$R_L = 100\Omega$, $C_L = 10$ pF (Figure 4 and Figure 5)			5	ns
t_{PLZ}	Disable Time Low to Z				5	ns
t_{PZH}	Enable Time Z to High				7	ns
t_{PZL}	Enable Time Z to Low				7	ns
f_{MAX}	Maximum Operating Frequency (Note 14)			200	250	

Note 1: "Absolute Maximum Ratings" are those values beyond which the safety of the device cannot be guaranteed. They are not meant to imply that the devices should be operated at these limits. The table of "Electrical Characteristics" specifies conditions of device operation.

Note 2: Current into device pins is defined as positive. Current out of device pins is defined as negative. All voltages are referenced to ground except: V_{OD1} and ΔV_{OD1} .

Note 3: All typicals are given for: $V_{CC} = +3.3V$, $T_A = +25^\circ C$.

Note 4: The DS90LV031A is a current mode device and only functions within datasheet specifications when a resistive load is applied to the driver outputs typical range is (90 Ω to 110 Ω)

Note 5: t_{SKD1} , $|t_{PHLD} - t_{PLHD}|$ is the magnitude difference in differential propagation delay time between the positive going edge and the negative going edge of the same channel.

Note 6: t_{SKD2} is the Differential Channel-to-Channel Skew of any event on the same device.

Note 7: t_{SKD3} , Differential Part to Part Skew, is defined as the difference between the minimum and maximum specified differential propagation delays. This specification applies to devices at the same V_{CC} and within 5 $^\circ C$ of each other within the operating temperature range.

Note 8: t_{SKD4} , part to part skew, is the differential channel-to-channel skew of any event between devices. This specification applies to devices over recommended operating temperature and voltage ranges, and across process distribution. t_{SKD4} is defined as $I_{Max} - I_{Min}$ differential propagation delay.

Note 9: Generator waveform for all tests unless otherwise specified: $f = 1$ MHz, $Z_O = 50\Omega$, $t_r \leq 1$ ns, and $t_f \leq 1$ ns.

Note 10: ESD Ratings:

HBM (1.5 k Ω , 100 pF) ≥ 6 kV

Note 11: Output short circuit current (I_{OS}) is specified as magnitude only, minus sign indicates direction only.

Note 12: C_L includes probe and jig capacitance.

Note 13: All input voltages are for one channel unless otherwise specified. Other inputs are set to GND.

Note 14: f_{MAX} generator input conditions: $t_r = t_f < 1$ ns, (0% to 100%), 50% duty cycle, 0V to 3V. Output Criteria: duty cycle = 45%/55%, $V_{OD} > 250$ mV, all channels switching.

Parameter Measurement Information

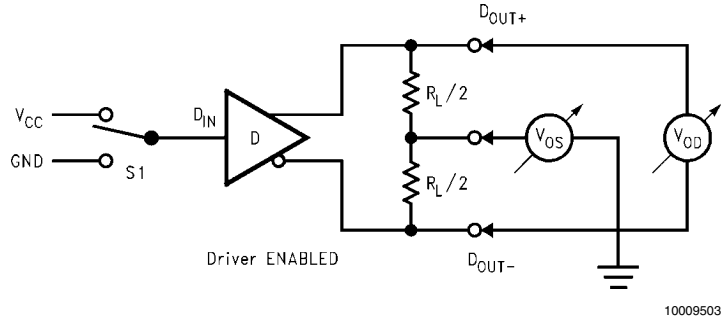

FIGURE 1. Driver V_{OD} and V_{OS} Test Circuit

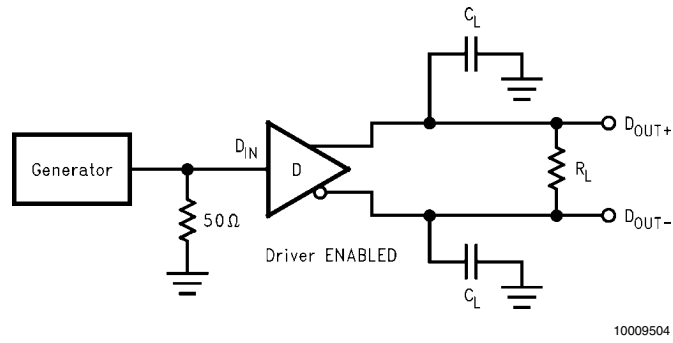

FIGURE 2. Driver Propagation Delay and Transition Time Test Circuit

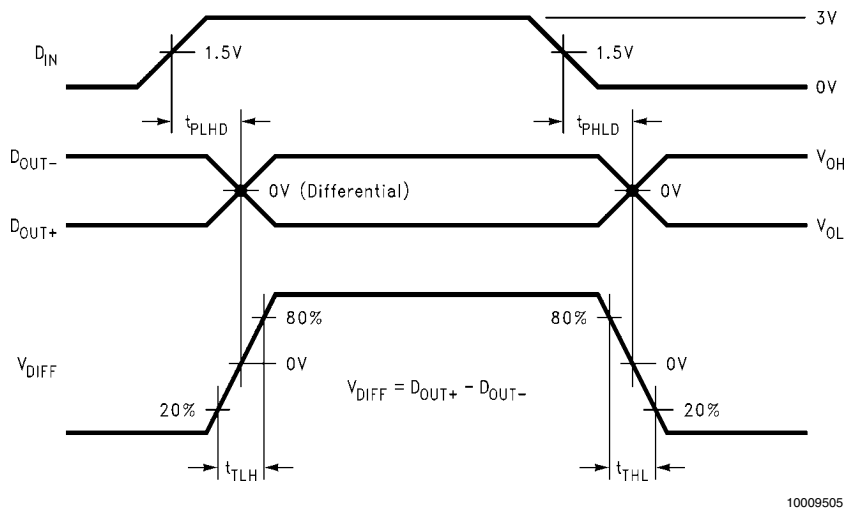
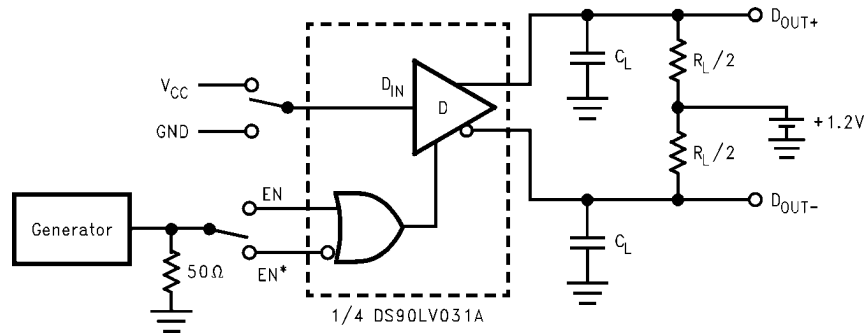
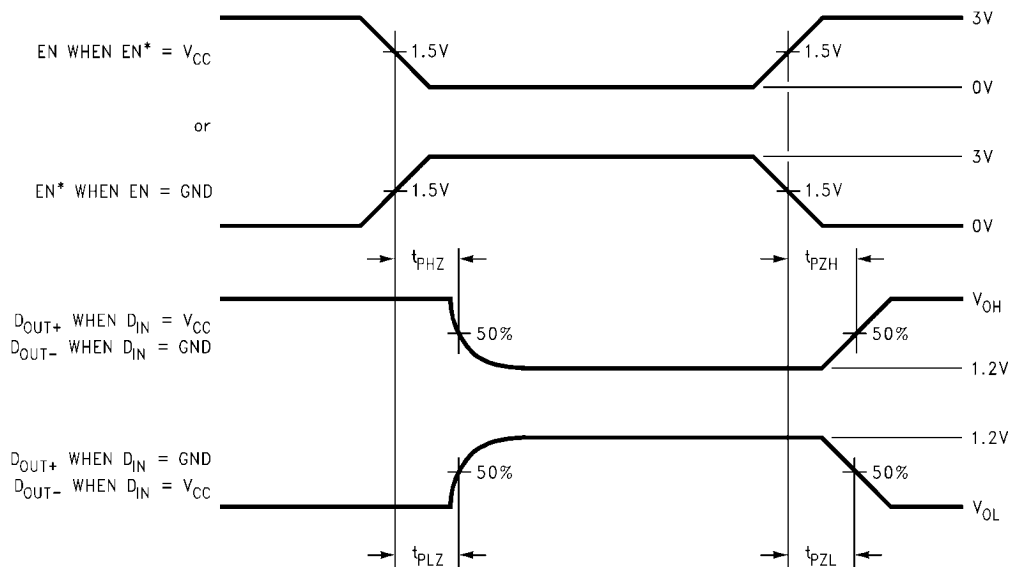

FIGURE 3. Driver Propagation Delay and Transition Time Waveforms



10009506

FIGURE 4. Driver TRI-STATE Delay Test Circuit



10009507

FIGURE 5. Driver TRI-STATE Delay Waveform

Applications Information

General application guidelines and hints for LVDS drivers and receivers may be found in the following application notes: LVDS Owner's Manual (lit #550062-001), AN808, AN1035, AN977, AN971, AN916, AN805, AN903.

LVDS drivers and receivers are intended to be primarily used in an uncomplicated point-to-point configuration as is shown in [Figure 7](#). This configuration provides a clean signaling environment for the quick edge rates of the drivers. The receiver is connected to the driver through a balanced media which may be a standard twisted pair cable, a parallel pair cable, or simply PCB traces. Typically, the characteristic differential impedance of the media is in the range of 100Ω. A termination resistor of 100Ω should be selected to match the media, and is located as close to the receiver input pins as possible. The termination resistor converts the current sourced by the driver into a voltage that is detected by the receiver. Other configurations are possible such as a multi-receiver configuration, but the effects of a mid-stream connector(s), cable stub(s), and other impedance discontinuities as well as ground shifting, noise margin limits, and total termination loading must be taken into account.

The DS90LV031A differential line driver is a balanced current source design. A current mode driver, generally speaking has a high output impedance and supplies a constant current for a range of loads (a voltage mode driver on the other hand supplies a constant voltage for a range of loads). Current is switched through the load in one direction to produce a logic state and in the other direction to produce the other logic state. The output current is typically 3.5 mA, a minimum of 2.5 mA, and a maximum of 4.5 mA. The current mode **requires** (as discussed above) that a resistive termination be employed to terminate the signal and to complete the loop as shown in [Figure 7](#). AC or unterminated configurations are not allowed. The 3.5 mA loop current will develop a differential voltage of 350 mV across the 100Ω termination resistor which the receiver detects with a 250 mV minimum differential noise margin neglecting resistive line losses (driven signal minus receiver threshold (350 mV – 100 mV = 250 mV)). The signal is centered around +1.2V (Driver Offset, V_{OS}) with respect to ground as shown in [Figure 6](#). Note that the steady-state voltage (V_{SS}) peak-to-peak swing is twice the differential voltage (V_{OD}) and is typically 700 mV.

The current mode driver provides substantial benefits over voltage mode drivers, such as an RS-422 driver. Its quiescent current remains relatively flat versus switching frequency. Whereas the RS-422 voltage mode driver increases exponentially in most case between 20 MHz–50 MHz. This is due to the overlap current that flows between the rails of the device when the internal gates switch. Whereas the current mode driver switches a fixed current between its output without any substantial overlap current. This is similar to some ECL and PECL devices, but without the heavy static I_{CC} requirements of the ECL/PECL designs. LVDS requires > 80% less current than similar PECL devices. AC specifications for the driver are a tenfold improvement over other existing RS-422 drivers. The TRI-STATE function allows the driver outputs to be disabled, thus obtaining an even lower power state when the transmission of data is not required.

The footprint of the DS90LV031A is the same as the industry standard 26LS31 Quad Differential (RS-422) Driver and is a step down replacement for the 5V DS90C031 Quad Driver.

Power Decoupling Recommendations:

Bypass capacitors must be used on power pins. High frequency ceramic (surface mount is recommended) 0.1μF in parallel with 0.01μF, in parallel with 0.001μF at the power supply pin as well as scattered capacitors over the printed circuit board. Multiple vias should be used to connect the decoupling capacitors to the power planes. A 10μF (35V) or greater solid tantalum capacitor should be connected at the power entry point on the printed circuit board.

PC Board considerations:

Use at least 4 PCB layers (top to bottom); LVDS signals, ground, power, TTL signals.

Isolate TTL signals from LVDS signals, otherwise the TTL may couple onto the LVDS lines. It is best to put TTL and LVDS signals on different layers which are isolated by a power/ground plane(s).

Keep drivers and receivers as close to the (LVDS port side) connectors as possible.

Differential Traces:

Use controlled impedance traces which match the differential impedance of your transmission medium (ie. cable) and termination resistor. Run the differential pair trace lines as close together as possible as soon as they leave the IC (stubs should be < 10mm long). This will help eliminate reflections and ensure noise is coupled as common-mode. Lab experiments show that differential signals which are 1mm apart radiate far less noise than traces 3mm apart since magnetic field cancellation is greater with the closer traces. Plus, noise induced on the differential lines is much more likely to appear as common-mode which is rejected by the receiver.

Match electrical lengths between traces to reduce skew. Skew between the signals of a pair means a phase difference between signals which destroys the magnetic field cancellation benefits of differential signals and EMI will result. (Note the velocity of propagation, $v = c/Er$ where c (the speed of light) = 0.2997mm/ps or 0.0118 in/ps). Do not rely solely on the auto-route function for differential traces. Carefully review dimensions to match differential impedance and provide isolation for the differential lines. Minimize the number of vias and other discontinuities on the line.

Avoid 90° turns (these cause impedance discontinuities). Use arcs or 45° bevels.

Within a pair of traces, the distance between the two traces should be minimized to maintain common-mode rejection of the receivers. On the printed circuit board, this distance should remain constant to avoid discontinuities in differential impedance. Minor violations at connection points are allowable.

Termination:

Use a resistor which best matches the differential impedance of your transmission line. The resistor should be between 90Ω and 130Ω. Remember that the current mode outputs need the termination resistor to generate the differential voltage. LVDS will not work without resistor termination. Typically, connect a single resistor across the pair at the receiver end.

Surface mount 1% to 2% resistors are best. PCB stubs, component lead, and the distance from the termination to the receiver inputs should be minimized. The distance between the termination resistor and the receiver should be < 10mm (12mm MAX).

Probing LVDS Transmission Lines:

Always use high impedance ($> 100k\Omega$), low capacitance ($< 2pF$) scope probes with a wide bandwidth (1GHz) scope. Improper probing will give deceiving results.

Cables and Connectors, General Comments:

When choosing cable and connectors for LVDS it is important to remember:

Use controlled impedance media. The cables and connectors you use should have a matched differential impedance of about 100Ω . They should not introduce major impedance discontinuities.

Balanced cables (e.g. twisted pair) are usually better than unbalanced cables (ribbon cable, simple coax.) for noise reduction and signal quality. Balanced cables tend to generate less EMI due to field canceling effects and also tend to pick up electromagnetic radiation as common-mode (not differen-

tial mode) noise which is rejected by the receiver. For cable distances $< 0.5M$, most cables can be made to work effectively. For distances $0.5M \leq d \leq 10M$, CAT 3 (category 3) twisted pair cable works well, is readily available and relatively inexpensive.

Fail-safe of an LVDS Interface

If the LVDS link as shown in [Figure 7](#) needs to support the case where the Line Driver is disabled, powered off, or removed (un-plugged) and the Receiver device is powered on and enabled, the state of the LVDS bus is unknown and therefore the output state of the Receiver is also unknown. If this is of concern, please consult the respective LVDS Receiver data sheet for guidance on Failafe Biasing options for the LVDS interface to set a known state on the inputs for these conditions.

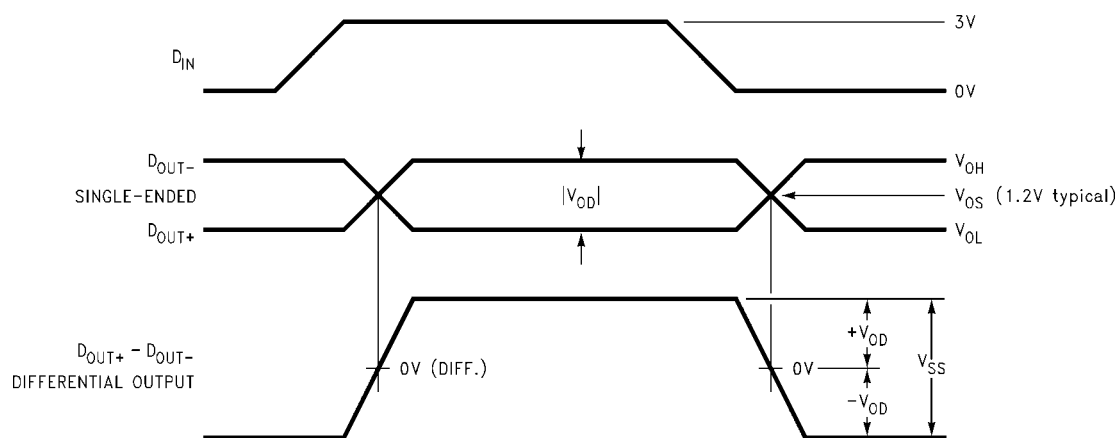

10009509

FIGURE 6. Driver Output Levels

Typical Application

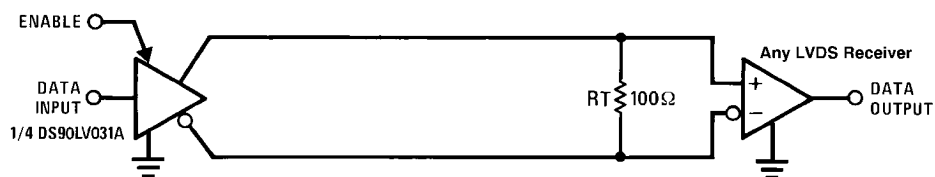

10009508

FIGURE 7. Point-to-Point Application

Typical Performance Curves

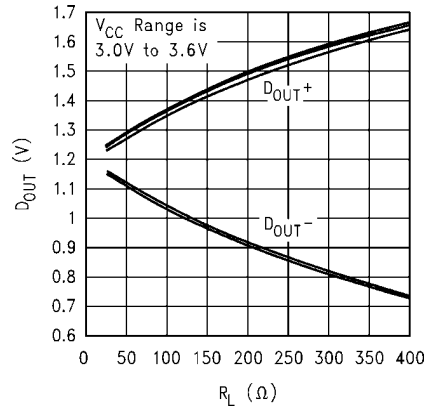

10009510

FIGURE 8. Typical DS90LV031A, D_{OUT} (single ended) vs R_L , $T_A = 25^\circ\text{C}$

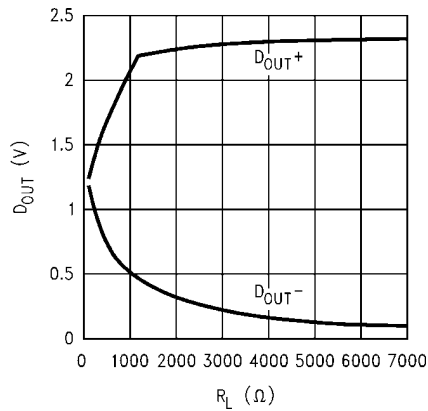

10009511

FIGURE 9. Typical DS90LV031A, D_{OUT} vs R_L ,
 $V_{CC} = 3.3\text{V}$, $T_A = 25^\circ\text{C}$

Pin Descriptions

Pin No.	Name	Description
1, 7, 9, 15	D_{IN}	Driver input pin, TTL/CMOS compatible
2, 6, 10, 14	D_{OUT+}	Non-inverting driver output pin, LVDS levels
3, 5, 11, 13	D_{OUT-}	Inverting driver output pin, LVDS levels
4	EN	Active high enable pin, OR-ed with EN*
12	EN*	Active low enable pin, OR-ed with EN
16	V_{CC}	Power supply pin, $+3.3\text{V} \pm 0.3\text{V}$
8	GND	Ground pin

Ordering Information

Package Type	Package Number	Order Number
SOP	M16A	DS90LV031ATM
TSSOP	MTC16	DS90LV031ATMTC

Physical Dimensions inches (millimeters) unless otherwise noted

DS90LV031A

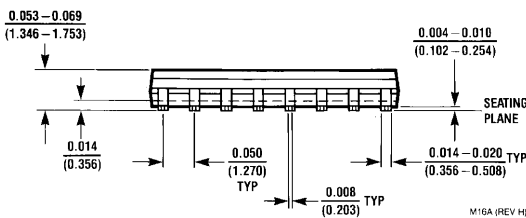
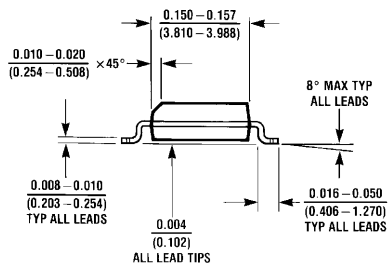
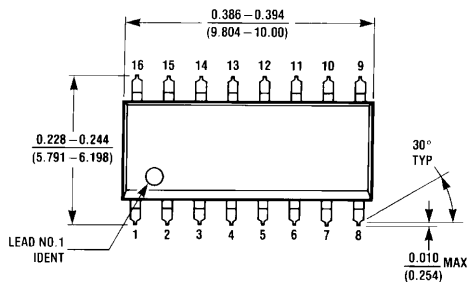

M16A (REV H)

16-Lead (0.150 Wide) Molded Small Outline Package, JEDEC
Order Number DS90LV031ATM
NS Package Number M16A

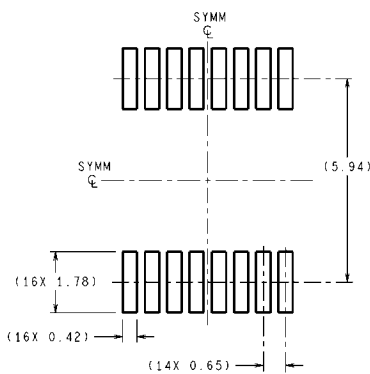
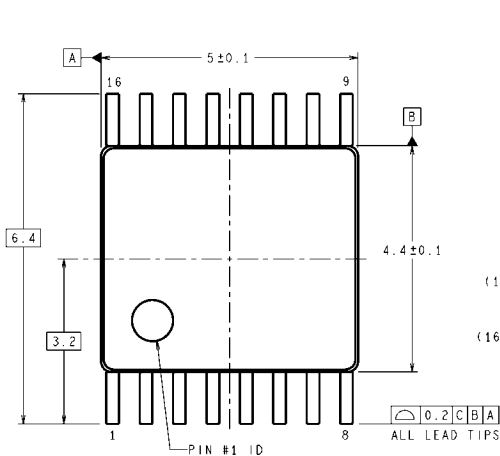

RECOMMENDED LAND PATTERN

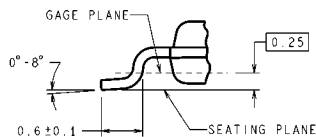

DETAIL A
TYPICAL

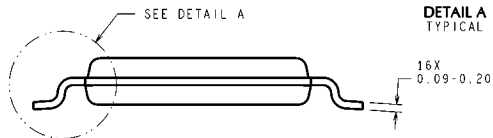
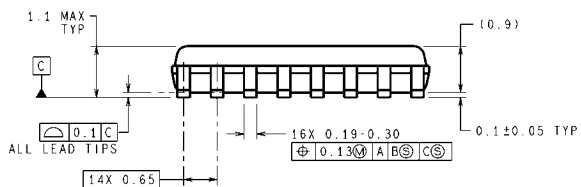

DIMENSIONS ARE IN MILLIMETERS
 DIMENSIONS IN () FOR REFERENCE ONLY

MTC16 (Rev D)

16-Lead (0.100 Wide) Molded Thin Shrink Small Outline Package, JEDEC
Order Number DS90LV031ATMTC
NS Package Number MTC16

Notes

For more National Semiconductor product information and proven design tools, visit the following Web sites at:
www.national.com

Products		Design Support	
Amplifiers	www.national.com/amplifiers	WEBENCH® Tools	www.national.com/webench
Audio	www.national.com/audio	App Notes	www.national.com/appnotes
Clock and Timing	www.national.com/timing	Reference Designs	www.national.com/refdesigns
Data Converters	www.national.com/adc	Samples	www.national.com/samples
Interface	www.national.com/interface	Eval Boards	www.national.com/evalboards
LVDS	www.national.com/lvds	Packaging	www.national.com/packaging
Power Management	www.national.com/power	Green Compliance	www.national.com/quality/green
Switching Regulators	www.national.com/switchers	Distributors	www.national.com/contacts
LDOs	www.national.com/ldo	Quality and Reliability	www.national.com/quality
LED Lighting	www.national.com/led	Feedback/Support	www.national.com/feedback
Voltage References	www.national.com/vref	Design Made Easy	www.national.com/easy
PowerWise® Solutions	www.national.com/powerwise	Applications & Markets	www.national.com/solutions
Serial Digital Interface (SDI)	www.national.com/sdi	Mil/Aero	www.national.com/milaero
Temperature Sensors	www.national.com/tempensors	SolarMagic™	www.national.com/solarmagic
PLL/VCO	www.national.com/wireless	PowerWise® Design University	www.national.com/training

THE CONTENTS OF THIS DOCUMENT ARE PROVIDED IN CONNECTION WITH NATIONAL SEMICONDUCTOR CORPORATION ("NATIONAL") PRODUCTS. NATIONAL MAKES NO REPRESENTATIONS OR WARRANTIES WITH RESPECT TO THE ACCURACY OR COMPLETENESS OF THE CONTENTS OF THIS PUBLICATION AND RESERVES THE RIGHT TO MAKE CHANGES TO SPECIFICATIONS AND PRODUCT DESCRIPTIONS AT ANY TIME WITHOUT NOTICE. NO LICENSE, WHETHER EXPRESS, IMPLIED, ARISING BY ESTOPPEL OR OTHERWISE, TO ANY INTELLECTUAL PROPERTY RIGHTS IS GRANTED BY THIS DOCUMENT.

TESTING AND OTHER QUALITY CONTROLS ARE USED TO THE EXTENT NATIONAL DEEMS NECESSARY TO SUPPORT NATIONAL'S PRODUCT WARRANTY. EXCEPT WHERE MANDATED BY GOVERNMENT REQUIREMENTS, TESTING OF ALL PARAMETERS OF EACH PRODUCT IS NOT NECESSARILY PERFORMED. NATIONAL ASSUMES NO LIABILITY FOR APPLICATIONS ASSISTANCE OR BUYER PRODUCT DESIGN. BUYERS ARE RESPONSIBLE FOR THEIR PRODUCTS AND APPLICATIONS USING NATIONAL COMPONENTS. PRIOR TO USING OR DISTRIBUTING ANY PRODUCTS THAT INCLUDE NATIONAL COMPONENTS, BUYERS SHOULD PROVIDE ADEQUATE DESIGN, TESTING AND OPERATING SAFEGUARDS.

EXCEPT AS PROVIDED IN NATIONAL'S TERMS AND CONDITIONS OF SALE FOR SUCH PRODUCTS, NATIONAL ASSUMES NO LIABILITY WHATSOEVER, AND NATIONAL DISCLAIMS ANY EXPRESS OR IMPLIED WARRANTY RELATING TO THE SALE AND/OR USE OF NATIONAL PRODUCTS INCLUDING LIABILITY OR WARRANTIES RELATING TO FITNESS FOR A PARTICULAR PURPOSE, MERCHANTABILITY, OR INFRINGEMENT OF ANY PATENT, COPYRIGHT OR OTHER INTELLECTUAL PROPERTY RIGHT.

LIFE SUPPORT POLICY

NATIONAL'S PRODUCTS ARE NOT AUTHORIZED FOR USE AS CRITICAL COMPONENTS IN LIFE SUPPORT DEVICES OR SYSTEMS WITHOUT THE EXPRESS PRIOR WRITTEN APPROVAL OF THE CHIEF EXECUTIVE OFFICER AND GENERAL COUNSEL OF NATIONAL SEMICONDUCTOR CORPORATION. As used herein:

Life support devices or systems are devices which (a) are intended for surgical implant into the body, or (b) support or sustain life and whose failure to perform when properly used in accordance with instructions for use provided in the labeling can be reasonably expected to result in a significant injury to the user. A critical component is any component in a life support device or system whose failure to perform can be reasonably expected to cause the failure of the life support device or system or to affect its safety or effectiveness.

National Semiconductor and the National Semiconductor logo are registered trademarks of National Semiconductor Corporation. All other brand or product names may be trademarks or registered trademarks of their respective holders.

Copyright© 2010 National Semiconductor Corporation

For the most current product information visit us at www.national.com



**National Semiconductor
Americas Technical
Support Center**
Email: support@nsc.com
Tel: 1-800-272-9959

**National Semiconductor Europe
Technical Support Center**
Email: europe.support@nsc.com

**National Semiconductor Asia
Pacific Technical Support Center**
Email: ap.support@nsc.com

**National Semiconductor Japan
Technical Support Center**
Email: jpn.feedback@nsc.com