	TYPE	NUMBER	
	PRODUCT SPECIFICATION	GS-12-100	
TITLE	MEG-Array™ 81, 100, 200, 240, 300, 400 & 528 Positions	PAGE	REVISION
		1 of 15	K
		AUTHORIZED BY	DATE
		D. Harper	04 Dec 09
CLASSIFICATION			
UNRESTRICTED			

1.0 OBJECTIVE

This specification defines the performance, test, quality, and reliability requirements of the MEG-Array™ .050" x.050" Grid High Density Connector System for Eutectic Sn Pb BGA as well as Lead Free BGA product that meets the requirements of the European Union Directive of Restrictions for Hazardous Substances (Directive 2002/95/EC).

2.0 SCOPE

This specification applies to the MEG-Array™ 0.50" x .050" Grid High Density Connector System which provides for parallel interconnection of printed wiring boards in low power applications.

3.0 GENERAL

<u>PARAGRAPH</u>	<u>TITLE</u>
1.0	Objective
2.0	Scope
3.0	General
4.0	Applicable Documents
5.0	Requirements
5.1	Qualification
5.2	Material
5.3	Finish
5.4	Design and Construction
6.0	Electrical Characteristics
7.0	Mechanical Characteristics
8.0	Environmental Conditions
9.0	Quality Assurance Provisions
9.1	Equipment Calibration
9.2	Inspection Conditions
9.3	Sample Quantities and Description
9.4	Qualification Testing
9.5	Requalification Testing

4.0 APPLICABLE DOCUMENTS

4.1 DRAWINGS & APPLICATION NOTE

4.1.3	81 Position 4.0mm mated height	
	55714	Plug
	55715	Receptacle
4.1.4	100 Position 4.0mm mated height	
	84512	Plug
	84513	Receptacle
4.1.5	200 Position 4.0mm mated height	
	84516	Plug
	84517	Receptacle
4.1.6	200 Position 8.0mm mated height	
	84516	Plug
	84535	Receptacle

	TYPE	NUMBER	
	PRODUCT SPECIFICATION	GS-12-100	
TITLE	MEG-Array™ 81, 100, 200, 240, 300, 400 & 528 Positions	PAGE	REVISION
		2 of 15	K
		AUTHORIZED BY	DATE
		D. Harper	04 Dec 09
		CLASSIFICATION	
		UNRESTRICTED	

4.1.7	200 Position 10.0mm mated height	
	84530	Plug
	84517	Receptacle
4.1.8	200 Position 12.0mm mated height	
	84530	Plug
	84535	Receptacle
4.1.9	240 Position 3.4mm mated height	
	74213	Plug
	74215	Receptacle
4.1.10	240 Position 4.0mm mated height	
	74213	Plug
	74217	Receptacle
4.1.11	240 Position 6.0mm mated height	
	74213	Plug
	55755	Receptacle
4.1.12	300 Position 4.0mm mated height	
	84500	Plug
	84501	Receptacle
4.1.13	300 Position 5.5mm mated height	
	84500	Plug
	84502	Receptacle
4.1.14	300 Position 8.0mm mated height	
	84500	Plug
	84553	Receptacle
4.1.15	300 Position 10.0mm mated height	
	84578	Plug
	84501	Receptacle
4.1.16	300 Position 11.5mm mated height	
	84578	Plug
	84502	Receptacle
4.1.17	300 Position 14.0mm mated height	
	84578	Plug
	84553	Receptacle
4.1.18	400 Position 4.0mm mated height	
	84740	Plug
	74221	Receptacle
4.1.19	400 Position 6.0mm mated height	
	84740	Plug
	74388	Receptacle
4.1.20	400 Position 8.0mm mated height	
	84740	Plug
	74390	Receptacle
4.1.21	400 Position 10.0mm mated height	
	84520	Plug
	74221	Receptacle

	TYPE	NUMBER	
	PRODUCT SPECIFICATION	GS-12-100	
TITLE	MEG-Array™ 81, 100, 200, 240, 300, 400 & 528 Positions	PAGE	REVISION
		3 of 15	K
		AUTHORIZED BY	DATE
		D. Harper	04 Dec 09
		CLASSIFICATION	
		UNRESTRICTED	

4.1.22	400 Position 12.0mm mated height	
	84520	Plug
	74388	Receptacle
4.1.23	400 Position 14.0mm mated height	
	84520	Plug
	74390	Receptacle
4.1.24	528 Position 6.0mm mated height	
	10022671	Plug
	10026846	Receptacle
4.1.25	Application Note	GS-20-033

4.2 OTHER STANDARDS AND SPECIFICATIONS

- 4.2.1 UL-94: Flammability
- 4.2.2 EIA 364: Electrical Connector/Socket Test Procedures Including Environmental Classifications
- 4.2.3 ASTM B122: Copper-Nickel-Tin Alloy
- 4.2.4 ASTM B194: Beryllium Copper Alloy
- 4.2.5 ASTM D5138: Std Specification for Liquid Crystal Polymers
- 4.2.6 ANSI/J-STD-005: Requirements for Soldering Pastes
- 4.2.7 ANSI/J-STD-004: Requirements for Soldering Fluxes
- 4.2.8 IEC 68-2-60 Ke: Flowing mixed gas Corrosion Test
- 4.2.9 ANSI-J-002: Solderability Tests for Component Leads, Terminations, Lugs, Terminals & Wires (paragraph 3.4.2 Steam Aging)
- 4.2.10 EIA-638 - Surface Mount Solderability Test

4.3 FCI SPECIFICATIONS

- 4.3.1 BUS-15-002/M: Nickel Plating
- 4.3.2 BUS-15-005/H: Gold Plating
- 4.3.3 GES-14-455: Packaging of MEG-Array Product
- 4.3.4 BUS-19-124: Solderball to Terminal Tensile Test Procedure
- 4.3.5 BUS-19-125; MEG Array Conn. 3 Point Bend Test Procedure

	TYPE	NUMBER	
	PRODUCT SPECIFICATION	GS-12-100	
TITLE	MEG-Array™ 81, 100, 200, 240, 300, 400 & 528 Positions	PAGE	REVISION
		4 of 15	K
		AUTHORIZED BY	DATE
		D. Harper	04 Dec 09
		CLASSIFICATION	
		UNRESTRICTED	

- 4.3.6 BUS-03-108: Crosstalk Test Methods
- 4.3.7 BUS-03-109: Rise Time Degradation Measurement
- 4.3.8 BUS-03-110: Characteristic Impedance
- 4.3.9 BUS-03-111: Propagation Delay Measurements
- 4.3.10 BUS-03-113: Inductance Measurement
- 4.3.11 GS-18-015: Product Quality Plan
- 4.3.12 BUS-03-601: Current Rating

4.4 FCI LAB REPORTS - SUPPORTING DATA

- 4.4.1 EL-97-12-057: MEG Array Connector Qualification
- 4.4.2 EL-97-08-085: MEG Array Impedance, propagation delay, crosstalk
- 4.4.3 EL-98-03-007A: 400 Pos. MEG Array Recept. Development Testing
- 4.4.4 EL-98-02-072: 3.4mm 240 Pos Recept. Durability & Hi Temp Life
- 4.4.5 EL-98-02-102: 4.0mm 400 Pos Recept. 3-Point Bend
- 4.4.6 EL-98-04-031^{CR}: 4.0mm 240 Pos Temp Cycle
- 4.4.7 EL-98-05-079: 240, 4.0mm Zipper Mating Forces
- 4.4.8 EL-98-12-069: 4.0mm, 400 Position Temp Cycling
- 4.4.9 SI-2002-03-001: Signal Integrity of 10mm, 12mm, & 14mm Stacked Height
- 4.4.10 EL-2003-10-09: Mating/Unmating Forces of 80, 81, 100 & 528 Positions
- 4.4.11 EL-2004-01-003CLead Free BGA Temperature cycling

5.0 REQUIREMENTS

- 5.1 QUALIFICATION Connectors furnished under this specification shall be products that are capable of meeting the qualification test requirements specified herein.

NOTE: 1) LLCR(Initial) for bulk resistance for 10mm, 12mm, and 14mm is in-progress.
2) Thermal cycling testing to include complete product line coverage with regards to position, size, and mated height is in-progress.
3) Electrical Characteristics – Signal Integrity (Capacitance, Propagation Delay, Characteristic Impedance, Crosstalk, Inductance)- Testing is in-progress for the 10mm, 12mm, and 14mm mated heights.

- 5.2 MATERIAL The material for each part shall be as specified herein, or equivalent. Substitute material shall meet the performance requirements of this specification.

5.2.1 Receptacle Terminal. The base material shall be beryllium copper alloy strip.

	TYPE	PRODUCT SPECIFICATION		NUMBER	GS-12-100			
	TITLE	MEG-Array™ 81, 100, 200, 240, 300, 400 & 528 Positions			PAGE	5 of 15	REVISION	K
				AUTHORIZED BY	D. Harper		DATE	04 Dec 09
				CLASSIFICATION	UNRESTRICTED			

5.2.2 Plug Terminal. The base material shall be copper-nickel-tin alloy strip.

5.2.3 Plug and Receptacle Insulator Housing. The insulators shall be molded of liquid crystal polymer that is rated 94V-0 or better in accordance with UL-94.

5.2.4 Solder Balls. Solder alloy 63 Tin/37 Lead or Lead Free 95.5Sn/4Ag/.5Cu

5.2.5 Solder Paste. Modified low resin content, no clean, with 63SN/37PB solder or Lead Free 95.5Sn/4Ag/.5Cu solder.

5.3 FINISH

5.3.1 The plug and receptacle terminals shall be plated in the contact area with 0.4 micrometers min. gold over 0.8 micrometers nickel.

5.4 DESIGN AND CONSTRUCTION. The connector shall be a multi-piece assembly having an array of contacts with solder balls attached, for installation on surface mount printed wiring boards or flexible circuits.

5.4.1 Mating. The connector shall be capable of mating and unmating manually without the use of special tools.

6.0 Electrical Characteristics

6.1 Contact Resistance, Low Level (LLCR) - The initial low level contact resistance shall not exceed (See Table) milliohms, with a max. 10 milliohms change after environmental exposure, when measured in accordance with EIA 364-23. The following details shall apply:

- | | | |
|----|----------------------|--|
| a) | 3.4mm mated height | 20 milliohms |
| | 4mm mated height | 20 milliohms |
| | 5.5mm mated height | 22 milliohms |
| | 6mm mated height | 23 milliohms |
| | 8mm mated height | 25 milliohms |
| | 10mm mated height | 30 milliohms |
| | 12mm mated height | 33 milliohms |
| | 14mm mated height | 37 milliohms |
| b) | Method of Connection | Attach current and voltage leads as shown in Figure 1. |
| c) | Test Voltage | 20 millivolts DC max open circuit |
| d) | Test Current | Not to exceed 100 milliamperes. |

8.0 Insulation Resistance – The insulation resistance of mated connectors shall not be less than 1000 megohms (1000 megohms after environmental exposure) when measured in accordance with EIA 364-21. The following details shall apply:

- Test Voltage – 200 volts DC.
- Electrification Time – 2 minutes, unless otherwise specified.
- Points of Measurement – Between adjacent and opposing contacts.

8.0 Dielectric Withstanding Voltage – There shall be no evidence of arc-over, insulation breakdown, or excessive leakage current (> 1 milliamperes) when mated connectors are tested in accordance with EIA 364-20. The following details shall apply:

	TYPE	NUMBER	
	PRODUCT SPECIFICATION	GS-12-100	
TITLE	MEG-Array™ 81, 100, 200, 240, 300, 400 & 528 Positions	PAGE	REVISION
		6 of 15	K
		AUTHORIZED BY	DATE
		D. Harper	04 Dec 09
		CLASSIFICATION	
		UNRESTRICTED	

- a) Test Voltage – 200 volts (DC RMS or AC, 60Hz).
- b) Test Duration – 60 seconds.
- c) Test Condition – 1 (760 Torr – sea level).
- d) Points of Measurement – Between adjacent and opposing contacts.

8.0 Current Rating – The temperature rise above ambient shall not exceed 30 °C at any point in the system when all contacts are powered at 0.45 ampere(s) or one contact is powered at 2.0 amperes. The following details shall apply:

- a) Ambient Conditions – Still air at 25 °C.
- b) Reference – BUS-03-601.
- c) A plug and receptacle were soldered to 38mm x 82 mm single sided board with solid layer of 3 oz. Copper. Power applied to connectors through wires screwed to corner of boards. Thermocouple located in center of connectors. See Figure 2.

8.0 Capacitance – The capacitance between adjacent and opposing contacts in a mated connector shall not exceed 1.0 picofarads when measured in accordance with EIA-364-30. The following details shall apply:

- a) Test frequency: 100 khz
- b) Preparation: The connectors shall be mated but not soldered to a P.C. board.
- c) Measurement points: The capacitance shall be measured across a minimum of 10 adjacent contacts.

6.6 Propagation Delay – The specification requirement shall be satisfied when evaluated in accordance with FCI Test Specification BUS-03-111 and the following details:

- a) Specification requirement 35ps. Max.(3.4 & 4mm mated height)
 - 5.5mm-mated height 60ps. Max estimated
 - 6mm-mated height 60ps.max.
 - 8mm-mated height 60ps.max.
 - 10mm mated height 60ps.max.
 - 12mm mated height 60ps.max.
 - 14mm mated height 63ps.max.

8.0 Characteristic Impedance – The specification requirement shall be satisfied when evaluated in accordance with FCI Test Specification BUS-03-110 and the following details:

- a) Input Rise Time (10% to 90%) = 100ps
- b) Specification requirement 50 ± 5 for 3.4 & 4.0mm mated height
Specification requirement 55 ± 5 for 5.5, 6 & 8mm mated height
In-progress- Specification requirement 55 ± 5 for 10, 12, 14mm mated height
- c) All signal contacts terminated with 50 ohm resistors.
- d) Connector terminated in a 4:1 signal to ground ratio

8.0 Crosstalk – The specification requirement shall be satisfied when evaluated in accordance with FCI Test Specification BUS-03-108 and the following details:

- a) Input Rise Time (10% to 90%) = 100ps

	TYPE	NUMBER	
	PRODUCT SPECIFICATION	GS-12-100	
TITLE	MEG-Array™ 81, 100, 200, 240, 300, 400 & 528 Positions	PAGE	REVISION
		7 of 15	K
		AUTHORIZED BY	DATE
		D. Harper	04 Dec 09
CLASSIFICATION			
UNRESTRICTED			

- b) Near End Crosstalk: 5% max.(4mm)
 - 5.5mm- 7.5% max estimated
 - 6mm- 7.5% max.
 - 8mm- 9% max.
 - 10mm 9% max.
 - 12mm 10% max.
 - 14mm 10% max.
- c) All signal contacts terminated with 50 ohm resistors.
- d) 4:1 Signal to Ground Ratio

8.0 Inductance – The specification requirement shall be satisfied by simulation:

- a) Specification requirement.

Product Mated Height	Partial Loop Inductance
4.0mm	1.48nH
5.5mm	2.48nH
6mm	2.88nH.
8mm	4.39nH
10mm	5.80nH
12mm	7.88nH
14mm	9.60nH

	TYPE PRODUCT SPECIFICATION	NUMBER GS-12-100	
TITLE MEG-Array™ 81, 100, 200, 240, 300, 400 & 528 Positions		PAGE 8 of 15	REVISION K
		AUTHORIZED BY D. Harper	DATE 04 Dec 09
CLASSIFICATION UNRESTRICTED			

FIGURE 1

Termination Resistance Measurement Points

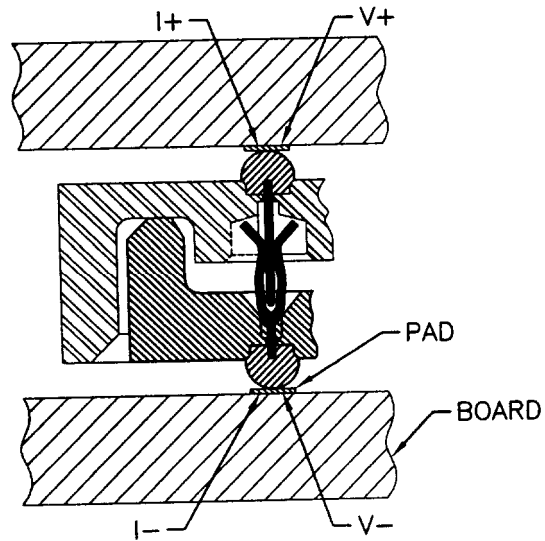

Note: If ambient temperature varies by more than 4° between measurements, all values shall be corrected to a standard ambient temperature.

	TYPE	NUMBER		
	PRODUCT SPECIFICATION		GS-12-100	
TITLE	MEG-Array™ 81, 100, 200, 240, 300, 400 & 528 Positions		PAGE	REVISION
			9 of 15	K
	AUTHORIZED BY	DATE	CLASSIFICATION	
D. Harper	04 Dec 09	UNRESTRICTED		

FIGURE 2

Maximum Current Set-up

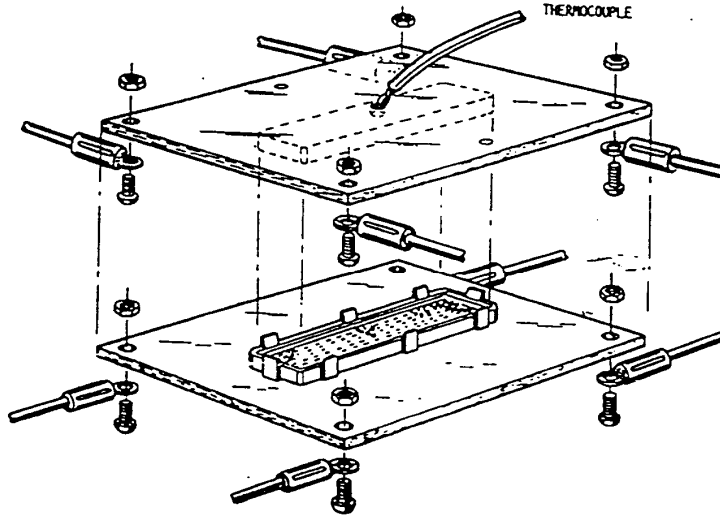

7.0 MECHANICAL CHARACTERISTICS

8.0 Mating/Unmating Force – Both plug and receptacle shall be soldered onto boards and the boards held in place by adequate fixturing to prevent cocking or misalignment, and shall be fully mated. Measurements are recorded for 3 mate/unmate cycles. Connectors are mated first on one end then the other end(zippered). See Figure 4

- a) Cross Head Speed – 5mm per minute.
- b) Lubrication – None

7.1.1 Total Mating Force

The max total mating force shall be:	<u>81 Pos.</u>	<u>100 Pos.</u>	<u>200 Pos.</u>
	7 Kgms*	14.5Kgms *	9Kgms*
	<u>240 Pos.</u>	<u>300 Pos.</u>	<u>528 Pos.</u>
	8 Kgms	10.5Kgms (est.)	20.5Kgms

7.1.2 Withdrawal Force

The max. withdrawal force shall be:	<u>81 Pos.</u>	<u>100 Pos.</u>	<u>200 Pos.</u>
	3.5 Kgms*	7.3Kgms*	6Kgms*
	<u>240 Pos.</u>	<u>300 Pos.</u>	<u>528 Pos.</u>
	8 Kgms	8Kgms (est.)	9Kgms

*Due to size of connector system, the zipper method was not used. All pins were mated and unmated at the same time.

	TYPE PRODUCT SPECIFICATION	NUMBER GS-12-100	
TITLE MEG-Array™ 81, 100, 200, 240, 300, 400 & 528 Positions		PAGE 10 of 15	REVISION K
		AUTHORIZED BY D. Harper	DATE 04 Dec 09
CLASSIFICATION UNRESTRICTED			

- 7.2 Solderball Pull Strength – The solderball pull strength in “Z” axis shall not be less than 1000gms per contact when tested in accordance with BUS-19-124. Connectors are not soldered onto board. The housing is held in a fixture while each terminal is gripped in a vise and pulled vertically out of the housing. The terminal is stripped out of the ball, leaving the ball on the housing bottom.
- 8.0 3-Point Bend – The connectors are soldered onto FR-4 bd. With pad geometry and footprint per FCI Customer drawing and Application Note 950554-002. The board is fixtured and bowed 20 mils/inch of board support distance (see Figure 3). Dye penetrant is applied to solder joints and dried. Conn. Is pried off board and solder joints are visually inspected for cracks that occurred during bending. Per BUS-19-125 3-Point Bend Procedure.

FIGURE 3 – 3-Point Bend Test

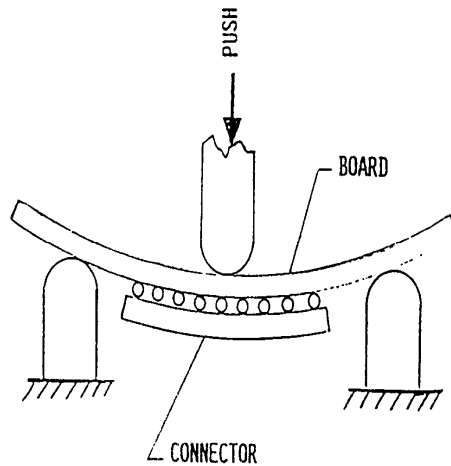



FIGURE 4

	TYPE PRODUCT SPECIFICATION	NUMBER GS-12-100	
TITLE MEG-Array™ 81, 100, 200, 240, 300, 400 & 528 Positions	PAGE 11 of 15	REVISION K	
	AUTHORIZED BY D. Harper	DATE 04 Dec 09	
CLASSIFICATION UNRESTRICTED			

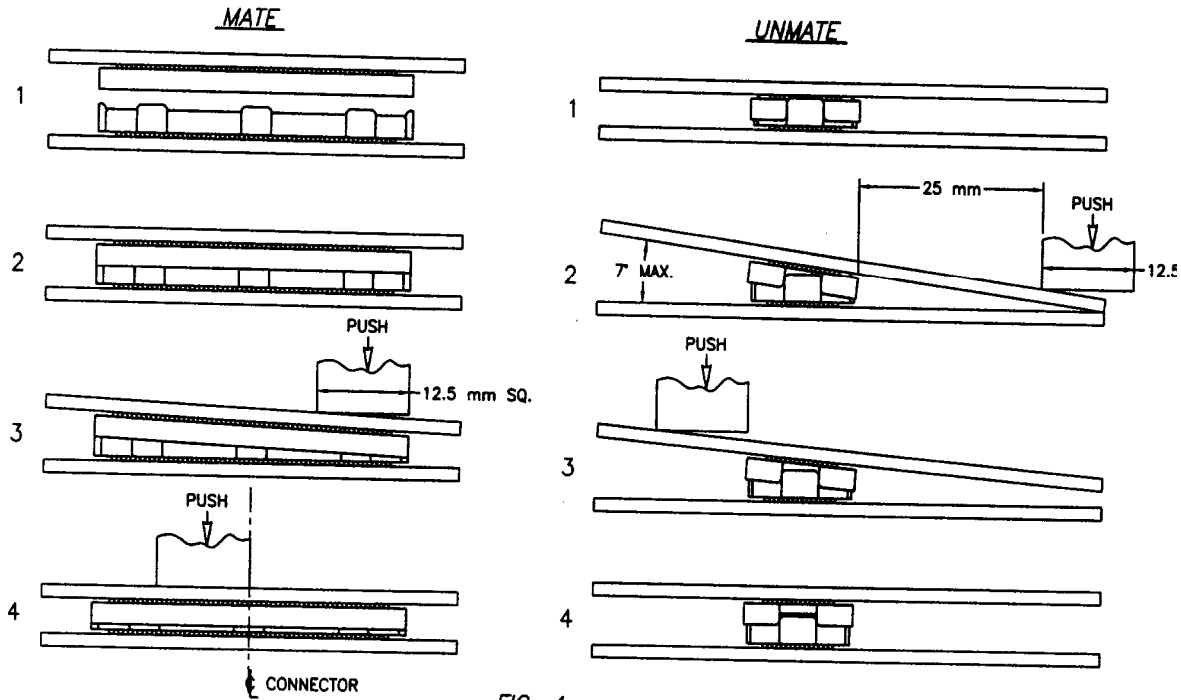



FIG. 4

VIEWS FOR MEG-Array Prod. Spec. GES-12-100
 Cad File: SJ9681c1 3-16-08
 REVD: 6-15-08

	TYPE	NUMBER	
	PRODUCT SPECIFICATION	GS-12-100	
TITLE	MEG-Array™ 81, 100, 200, 240, 300, 400 & 528 Positions	PAGE	REVISION
		12 of 15	K
		AUTHORIZED BY	DATE
		D. Harper	04 Dec 09
		CLASSIFICATION	
		UNRESTRICTED	

8.0 ENVIRONMENTAL CONDITIONS

After exposure to the following environmental conditions in accordance with the specified test procedure and/or details, the product shall show no physical damage and shall meet the electrical and mechanical requirements per sections 6.0 and 7.0 as specified in the Table 1 test sequences. Unless specified otherwise, assemblies shall be mated during exposure.

8.1. Temperature Cycling – At increments of 300 temp. cycles, contact resistance shall pass the requirements of Paragraph 6.1. Optionally, samples may be wired in series, with less than 100% increase in total resistance from initial value (recorded at hot temperature).

- a) Number of Cycles – 1000
- b) Temperature Range – Between -40 and 85 °C
- c) Time for Each Cycle – 30 minutes (approx. 24 days to total)

8.2 Humidity – EIA 364-31, Method II.

Connectors shall be tested at accelerated humidity. Upon completion of exposure period, they shall be conditioned at room ambient for a period of four hours.

- a) Relative Humidity 95%
- b) Temperature 40°C
- c) Test Condition A (96 hours)

8.0 High Temperature Life – EIA 364-17.

- a) Test Temperature – 85 °C ± 5 °C
- b) Test Duration – 500 hours

8.0 Durability – EIA 364-09

The connector halves shall be mated/unmated 50 times. After cycling, the contacts shall meet the requirements of paragraphs 6.1, 7.1 & 8.5 of this specification. The test shall be performed with plug & receptacle soldered to board.

8.0 Corrosive Atmosphere – IEC 68-2-60 Ke

Connectors shall be mated when exposed to the environment. Upon completion of the exposure, the contacts shall pass the requirements of paragraph 6.1 of this specification. The mated connectors shall not be disturbed during this test.

Using connectors mounted to the appropriate printed wiring board, they shall be exposed to a mixed gas atmosphere, to be placed in the test chamber of a sufficient volume to result in saturation of the test chamber.

- a) Relative humidity: 75%
- b) Exposure time: 96 hours
- c) Temperature: 40 ° ± 5 °C
- d) H2S: 3 ± 1 ppm
- e) SO2: 10 ± 3 ppm

	TYPE PRODUCT SPECIFICATION	NUMBER GS-12-100	
TITLE MEG-Array™ 81, 100, 200, 240, 300, 400 & 528 Positions		PAGE 13 of 15	REVISION K
		AUTHORIZED BY D. Harper	DATE 04 Dec 09
CLASSIFICATION UNRESTRICTED			

8.0 Solderability – EIA-638

Solder paste is deposited on a ceramic plate via stencil in the pattern per customer drawing. The connectors are steam aged and placed onto the solder paste print. The substrate is processed through a forced hot air convection oven with nitrogen blanket. The connectors are removed from the ceramic and solder balls inspected for bridging and wetting.

- a) Steam age 1 hour per ANSI-J-STD-002 (paragraph 3.4.2)
- b) Solder paste Alpha LR735 no clean
- c) Ceramic plate .9mm thick
- d) Temperature profile;
 - Eutectic: 230 ° C max., over 183 ° C, 45 -90 seconds, 60 – 120 ° C/min ramp until 110 ° to 130 ° C soak, soak 1.5 to 2.0 min.
 - Lead Free; 260 ° C max., over 218 ° C, 40 -70 seconds, 60 – 120 ° C/min ramp until 140 ° to 160 ° C soak, soak 1.5 to 2.0 min.

9.0 QUALITY ASSURANCE PROVISIONS

8.0 Equipment Calibration

All test equipment and inspection facilities used in the performance of any test shall be maintained in a calibration system in accordance with ANSI/NCSL Z-540-1

8.0 Inspection Conditions

Unless otherwise specified herein, all inspections shall be performed under the following ambient conditions:

- a) Temperature: 25 ± 5° C.
- b) Barometric pressure: Local ambient



	TYPE	PRODUCT SPECIFICATION		NUMBER	GS-12-100			
	TITLE	MEG-Array™ 81, 100, 200, 240, 300, 400 & 528 Positions			PAGE	14 of 15	REVISION	K
				AUTHORIZED BY	D. Harper		DATE	04 Dec 09
				CLASSIFICATION	UNRESTRICTED			

TABLE 1 – QUALIFICATION TESTING

TEST	PA	TEST GROUP									
		1	2	3	4	5	6	7	8	9	10
		TEST SEQUENCE									
Examination of Product	5.4	1	1	1	1	1	1	1	1	1	1
Contact Resistance Low Level	6.1	3 5 8	2 4		2 5						
Insulation Resistance	6.2			2 6							
Dielectric Withstanding Voltage	6.3			3 7							
Current Rating	6.4					2					
Capacitance	6.5			4 8							
Propagation Delay	6.6						2				
Characteristic Impedance	6.7						3				
Crosstalk	6.8						4				
Inductance	6.9						5				
Rise Time Degradation	6.1						6				
Mating/Unmating Force	7.1	2 6			3 6						
Solderball Pull Strength	7.2									2	
3-Point Bend	7.3										2
Temperature Cycling	8.1							2			
Humidity	8.2		3	5							
Hi Temperature Life	8.3				4						
Durability	8.4	4									
Corrosive Atmosphere	85	7									
Solderability	8.6								2		
Qty. Conns./Group		3		3	3	1	3	30	3	3	3

8.1 - Refer to EIA-540B000 for Sample Quantities

	TYPE	PRODUCT SPECIFICATION		NUMBER	GS-12-100			
	TITLE	MEG-Array™ 81, 100, 200, 240, 300, 400 & 528 Positions			PAGE	15 of 15	REVISION	K
				AUTHORIZED BY	D. Harper		DATE	04 Dec 09
				CLASSIFICATION	UNRESTRICTED			

REVISION RECORD

REV	PAGE	DESCRIPTION	EC #	DATE
1	All	Preliminary	V70712	04/21/97
2	ALL	Add dwg. Numbers, ref. Berg specs., add cleanliness, add Figures 2 & 3, and 7.2 & 7.3 and renumber	V71445	10/06/97
3	1-12	Update 4.1.1,4.1.2 & 4.1.3. Change 4.3.7,4.3.9,6.1,6.4, 7.1.1,7.1.2,7.3,8.1,8.5,8.6,9.1& 9.2	V80007	01/06/98
4	All	Delete 4.1.1,4.5.1. Change 4.1.2,4.1.3,4.5.2,&4.5.3.	V80262	03/17/98
5	3,5,6,8,9	Pg. 3, 6.1 a change 12 to 20, 16 to 25. Pg. 5 change 6.8.b ,change 75% to 7.5. Pg. 8 , 8.3 b change 240 to 500 hours. 6.9 add test in process. Add (d) to 8.1.	V81012	07/09/98
6	9	8.0 change b) from -25 and 100 to -40 and 85.	V81066	09/22/98
A	All	New Release	V90413	03/31/99
B	ALL	Revised format to be consistent with GS-01-001, and change BERG, Dupont, etc. references to FCI. Change document number prefix from GES to GS.	V01949	08/16/00
C	ALL	Add Products	V10218	3/12//01
D	ALL	Add Products	V21506	4/02/03
E	ALL	Add Products	V03-1179	10/27/03
F	3	Add Inductance Simulation Values	V03-1244	11/19/03
G	All	Add Lead Free BGA information	V04-0883	9/17/04
H	All	Change logo	V06-0539	6/2/06
J	All	Removed 80 Position information and add 200 position mating and un-mating force information	V06-0858	8/28/06
K	Page 5	Section 6.1 LLCR for 10, 12, 14mm	V09-0562	12/04/09