

RS-232 Interface to the CAN-Bus Micro-Controller

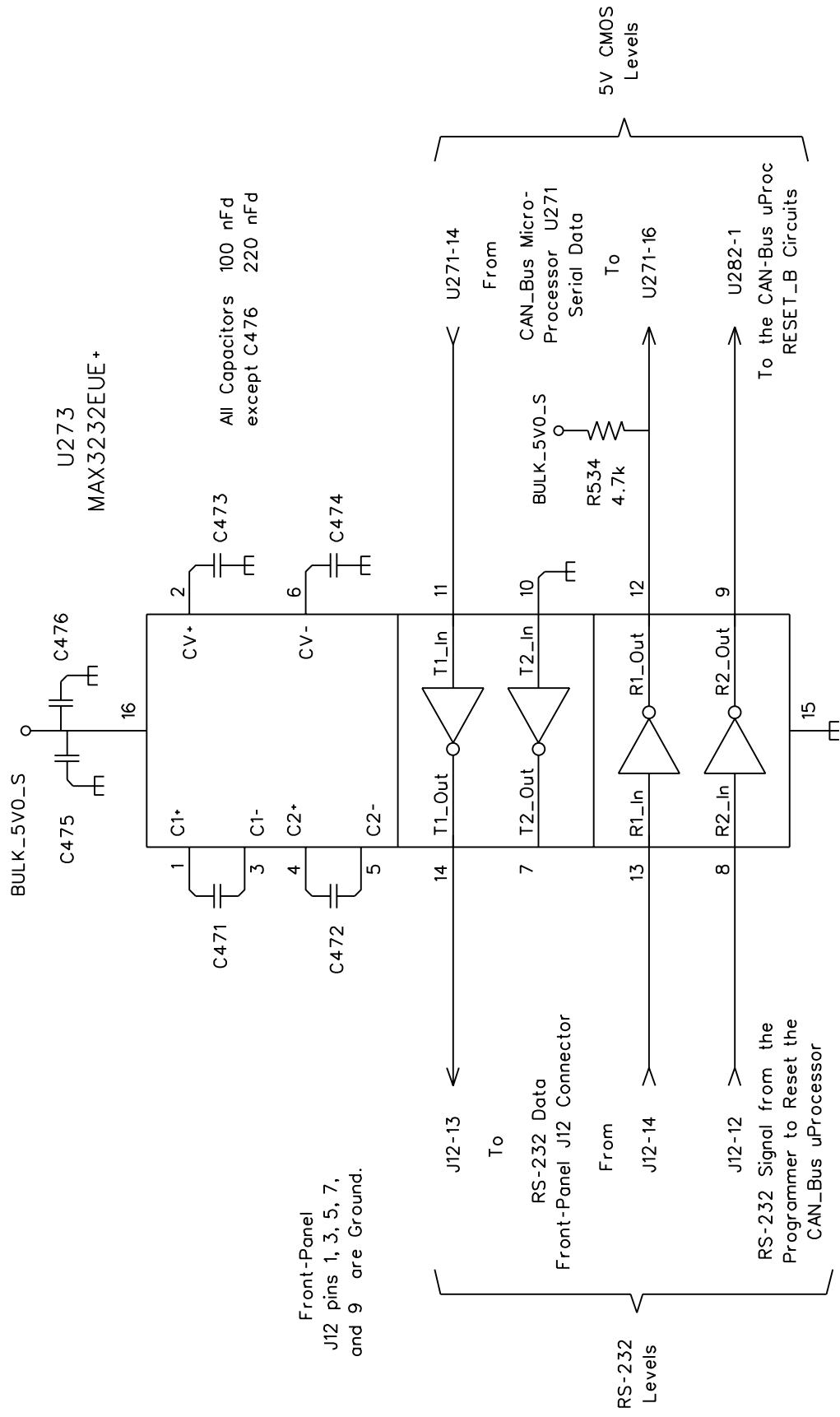

Both the transmitters and receivers are level inverting.
The receiver inputs have internal 5k Ohm pull-down resistors.