

© CBT TECHNOLOGY, INC. IN THIS DRAWING IS THE PROPRIETARY AND CONFIDENTIAL PROPERTY OF CBT. ANY REPRODUCTION OR DISCLOSURE IN PART OR WHOLE WITHOUT PRIOR WRITTEN CONSENT OF CBT TECHNOLOGY, INC. IS PROHIBITED.

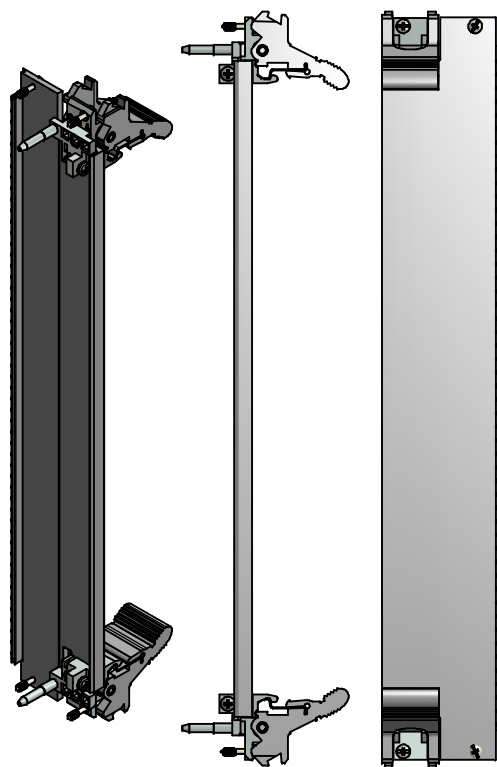

6U 8HP  
Ejector PCB Mounts

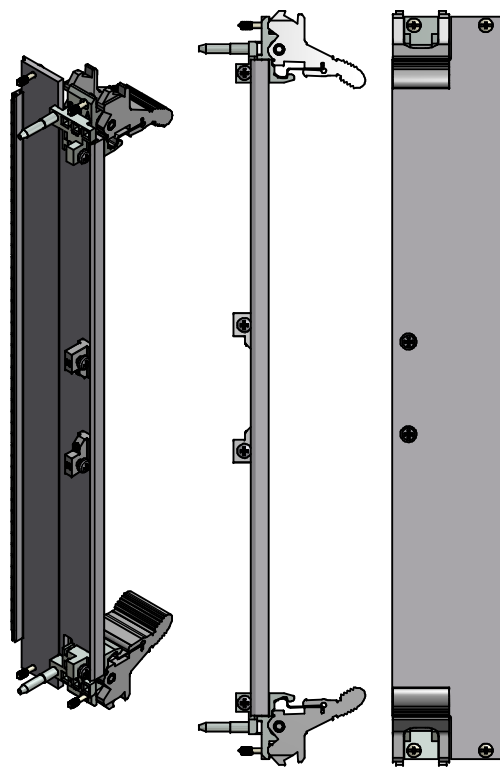

6U 8HP  
Ejector and Attached  
Center PCB Mounts

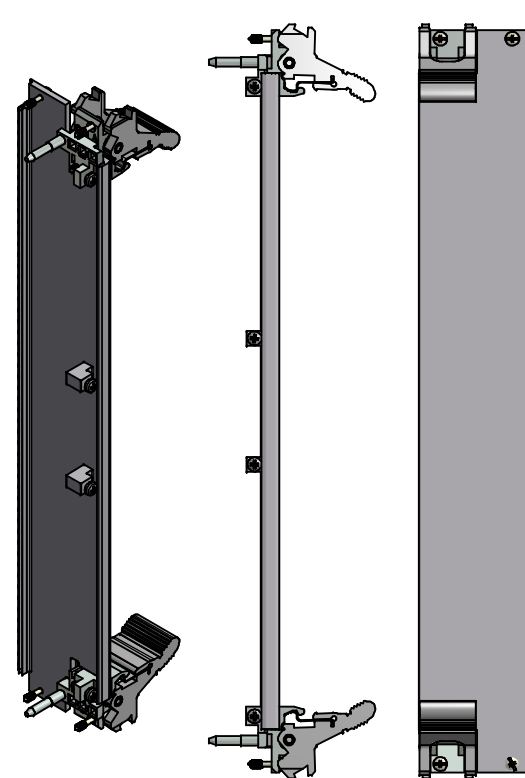

6U 8HP  
Ejector and Integral  
Center PCB Mounts

**PANELS ARE COMPATIBLE  
WITH EJECTORS SHOWN**  
(Rittal compatible front panels also available)

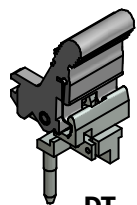

**DT**  
Standard  
Aluminum  
Standard Finish Black Powder Coat

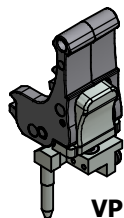

**VP**  
VPX Locking  
Stainless Steel  
Standard Finish Black Powder Coat

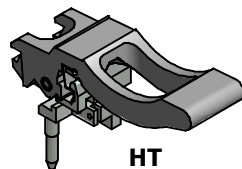

**HT**  
High Torque  
Aluminum  
Standard Finish Black Powder Coat

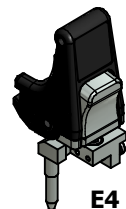

**E4**  
"Patriot" Locking  
Plastic

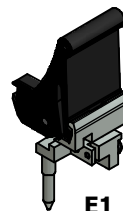

**E1**  
Standard  
Plastic

See our CBT Direct store for information on availability, lead time, and ordering. Front panels can be customized for your I/O configurations on request. Silk screening and other finishing options available.



ISO 9001 2008

CQI CONTINUOUS QUALITY IMPROVEMENT



CBT Technology  
358 North Street  
Randolph, MA 02368 USA  
www.cbttechnology.com  
781-963-7200 (Fax-7203)

1101.10, 6U 8HP Front Panels

© CBT TECHNOLOGY, INC. IN THIS DRAWING IS THE PROPRIETARY AND CONFIDENTIAL PROPERTY OF CBT. ANY REPRODUCTION OR DISCLOSURE IN PART OR WHOLE WITHOUT PRIOR WRITTEN CONSENT OF CBT TECHNOLOGY, INC. IS PROHIBITED.

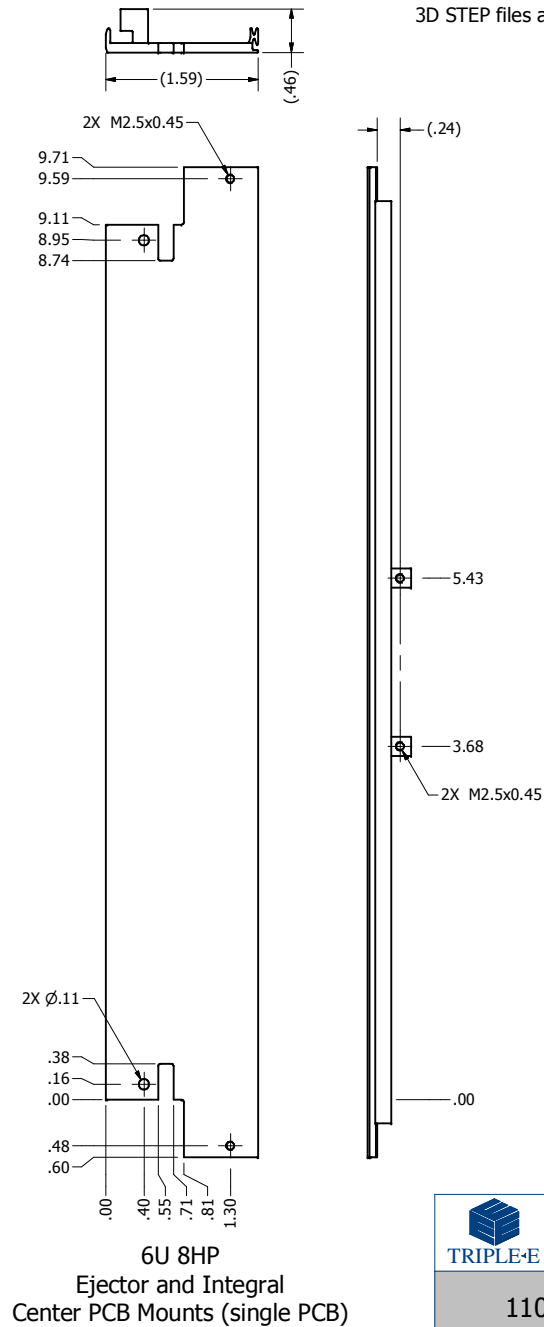
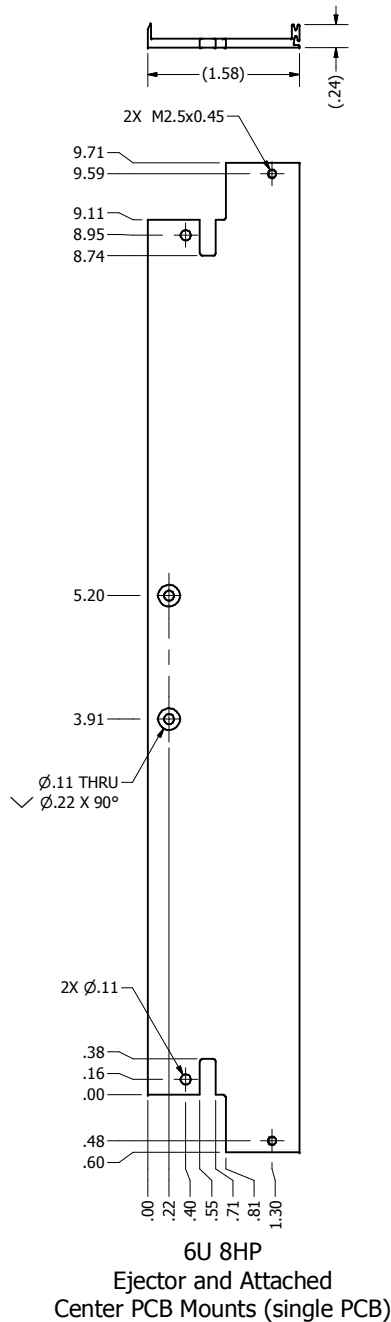
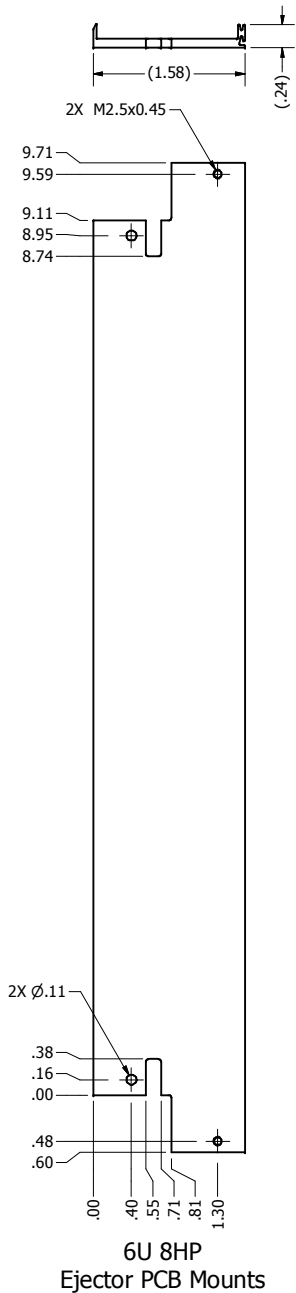

Panels are made from Aluminum Alloy 6005-T5  
 Front panels shown are compatible with TripleE ejectors:  
 DT, HT, & VP, as well as Purcell E1 & E4  
 Finish is a grain and clear Trivalent Chromate  
 Consult factory for delivery on non-stock configurations  
 3D STEP files available on [www.tripleease.com](http://www.tripleease.com) web site

 <b>TRIPLE-E</b>	 <b>ISO 9001 2008</b>	 <b>CQI</b> <small>CONTINUOUS QUALITY IMPROVEMENT</small>	 <b>RoHS COMPLIANT</b>	CBT Technology 358 North Street Randolph, MA 02368 USA <a href="http://www.cbttechnology.com">www.cbttechnology.com</a> 781-963-7200 (Fax-7203)
--	---	--	--	---

1101.10, 6U 8HP Front Panels