

Project file:cmx_vme_vat.cpm

SYSTEM: SPB 16.3

EDA-02515-V1-0

PROJECT:CMX VME Testboard

MODULE:cmx_vme_vat

Sheet: 1/15 Module: 1/15 Project: 1/15

LAST_MODIFIED=Wed May 23 16:20:51 2012

Design by: Y. Ermoline

PCB by: <PCB_BY>

DATE: 11/04/2012



European Organization
for Nuclear Research
1211 GENEVA 23
SWITZERLAND

TS/DEM

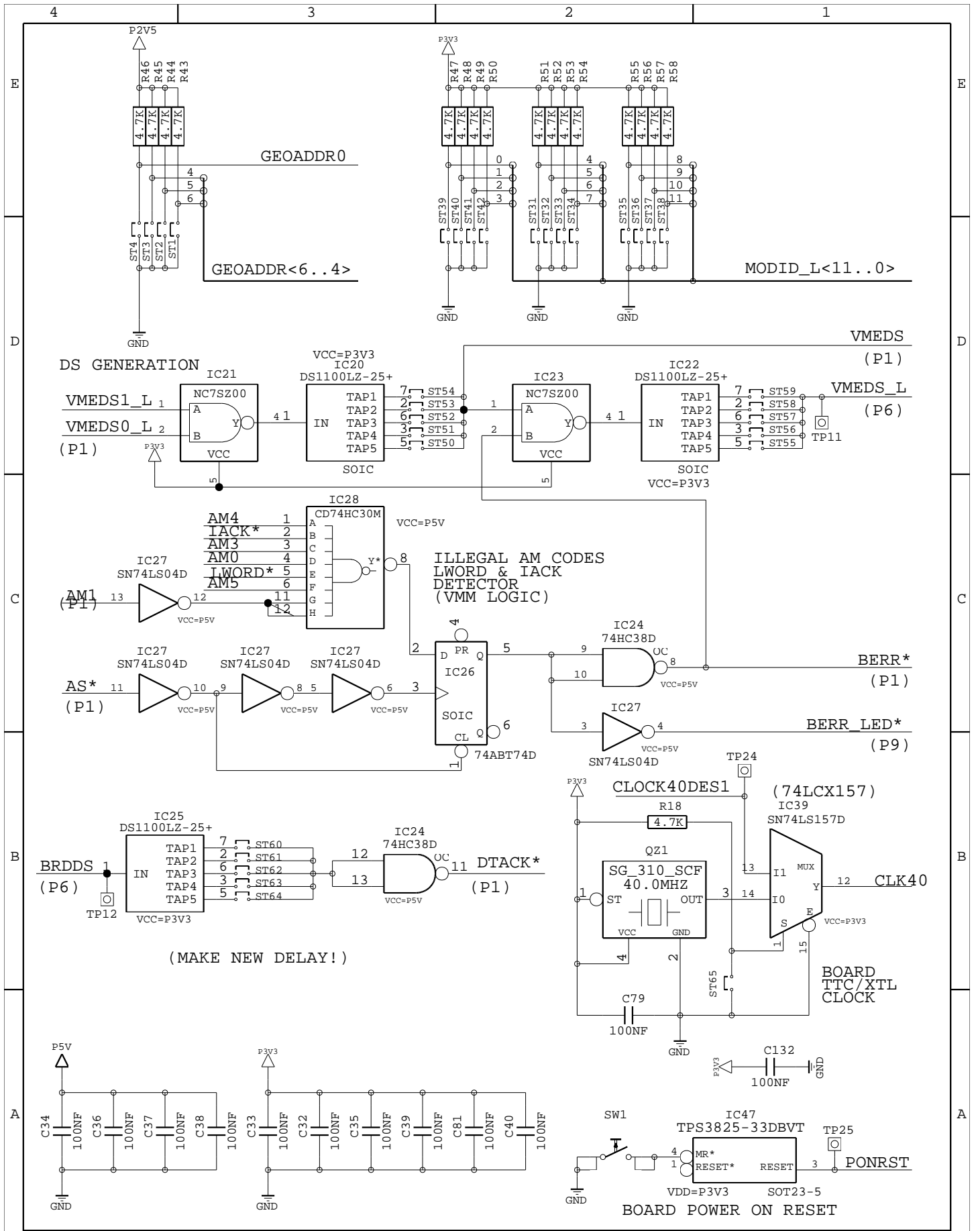

Project file:cmx_vme_vat.cpm

SYSTEM: SPB 16.3

EDA-02515-V1-0

PROJECT:CMX VME Testboard

MODULE:cmx_vme_vat

Sheet: 2/15 / Project: 2/15

LAST_MODIFIED=Wed May 23 16:20:52 2012

Design by: Y. Ermoline

PCB by: <PCB_BY>

DATE: 11/04/2012

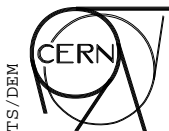

European Organization
for Nuclear Research
1211 GENEVA 23
SWITZERLAND

TS/DEM

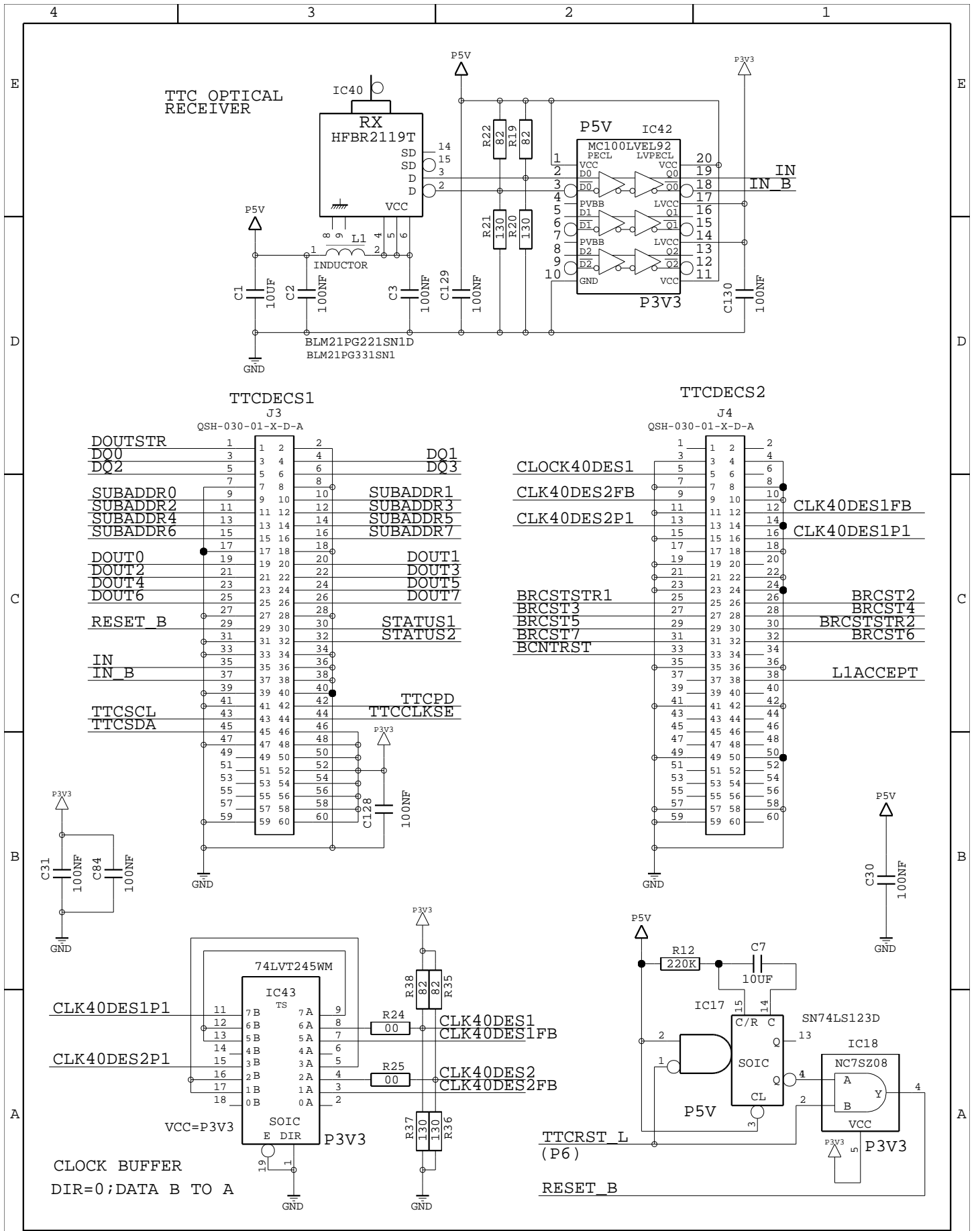

Project file: cmx_vme_vat.cpm

SYSTEM: SPB 16.3

EDA-02515-V1-0

PROJECT: CMX VME Testboard

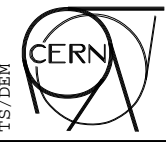

European Organization
for Nuclear Research
1211 GENEVA 23
SWITZERLAND

MODULE: cmx_vme_vat	Sheet: 3/15	Project: 3/15
LAST_MODIFIED=Wed May 23 16:20:53 2012		
Design by: Y. Ermoline	PCB by: <PCB_BY>	DATE: 11/04/2012

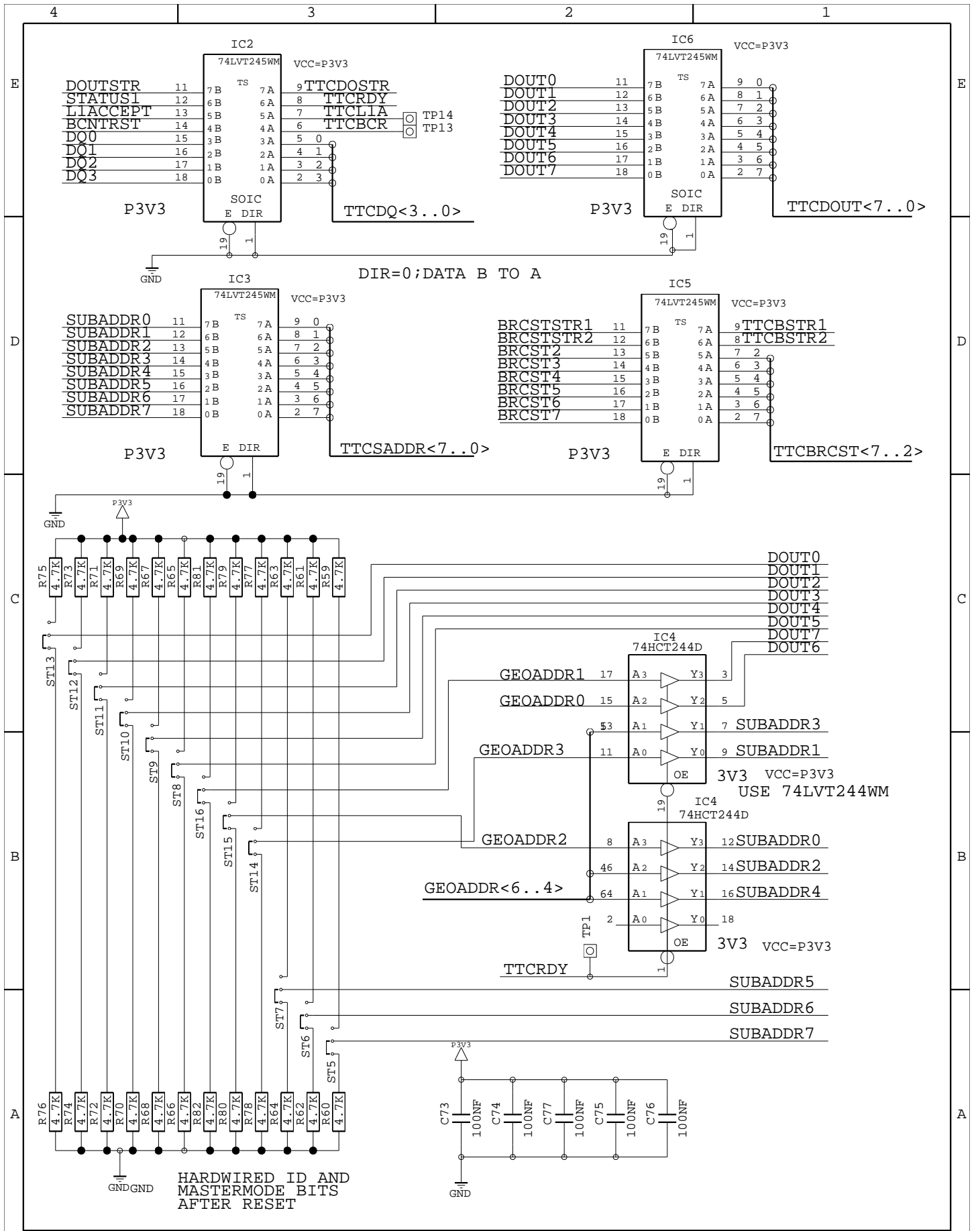

Project file:cmx_vme_vat.cpm

SYSTEM: SPB 16.3

EDA-02515-V1-0

PROJECT:CMX VME Testboard

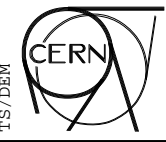

European Organization
for Nuclear Research
1211 GENEVA 23
SWITZERLAND

MODULE:cmx_vme_vat	Sheet: 4/15	Project: 4/15
LAST_MODIFIED=Wed May 23 16:20:53 2012		
Design by: Y. Ermoline	PCB by: <PCB_BY>	DATE: 11/04/2012

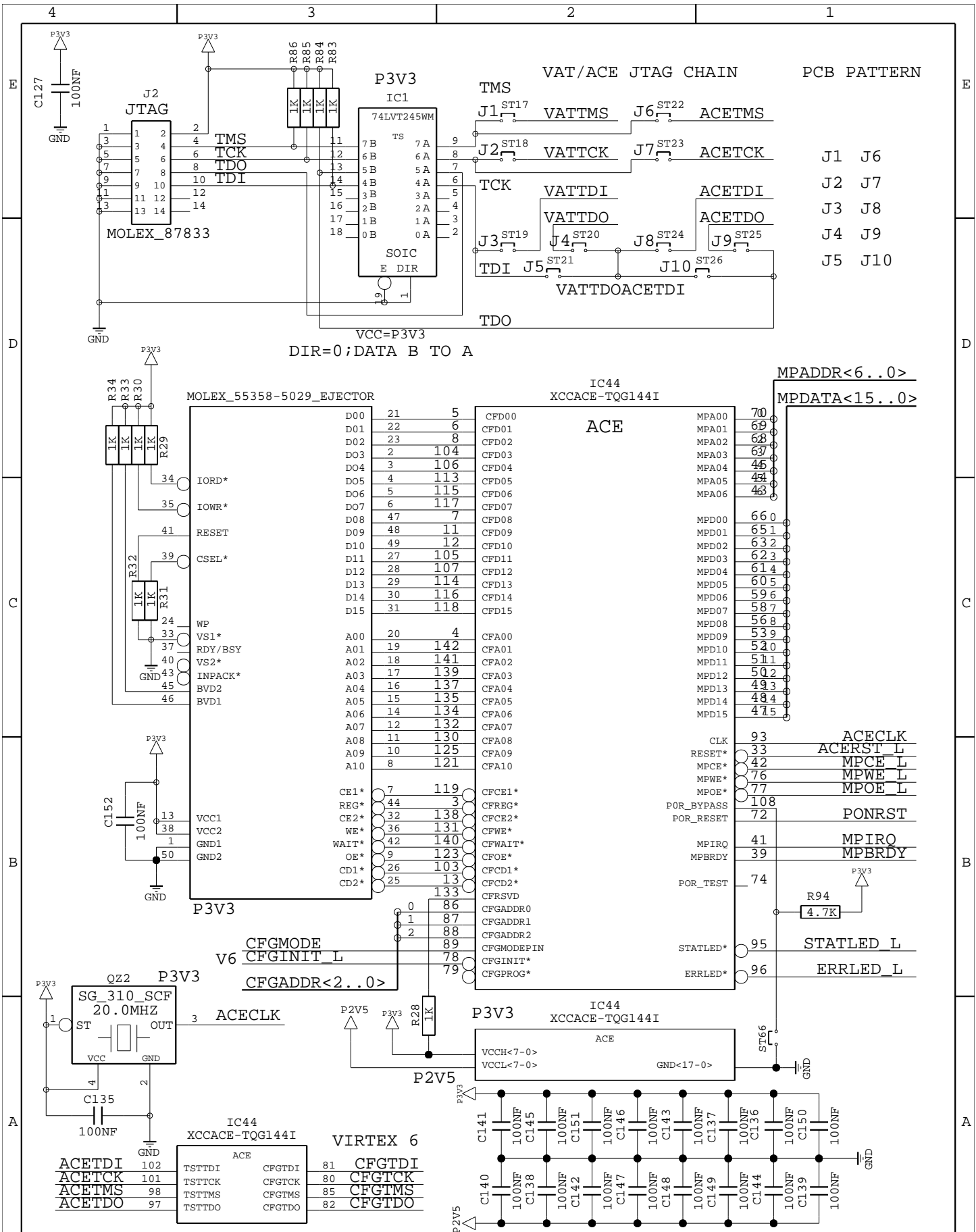

Project file:cmx_vme_vat.cpm

SYSTEM: SPB 16.3

EDA-02515-V1-0

PROJECT:CMX VME Testboard



European Organization
 for Nuclear Research
 1211 GENEVA 23
 SWITZERLAND

MODULE:cmx_vme_vat	Sheet: 5/15	Project: 5/15
LAST_MODIFIED=Whd Max 26 10:40:54 2012		
Design by: Y. Ermoline	PCB by: <PCB_BY>	DATE: 11/04/2012

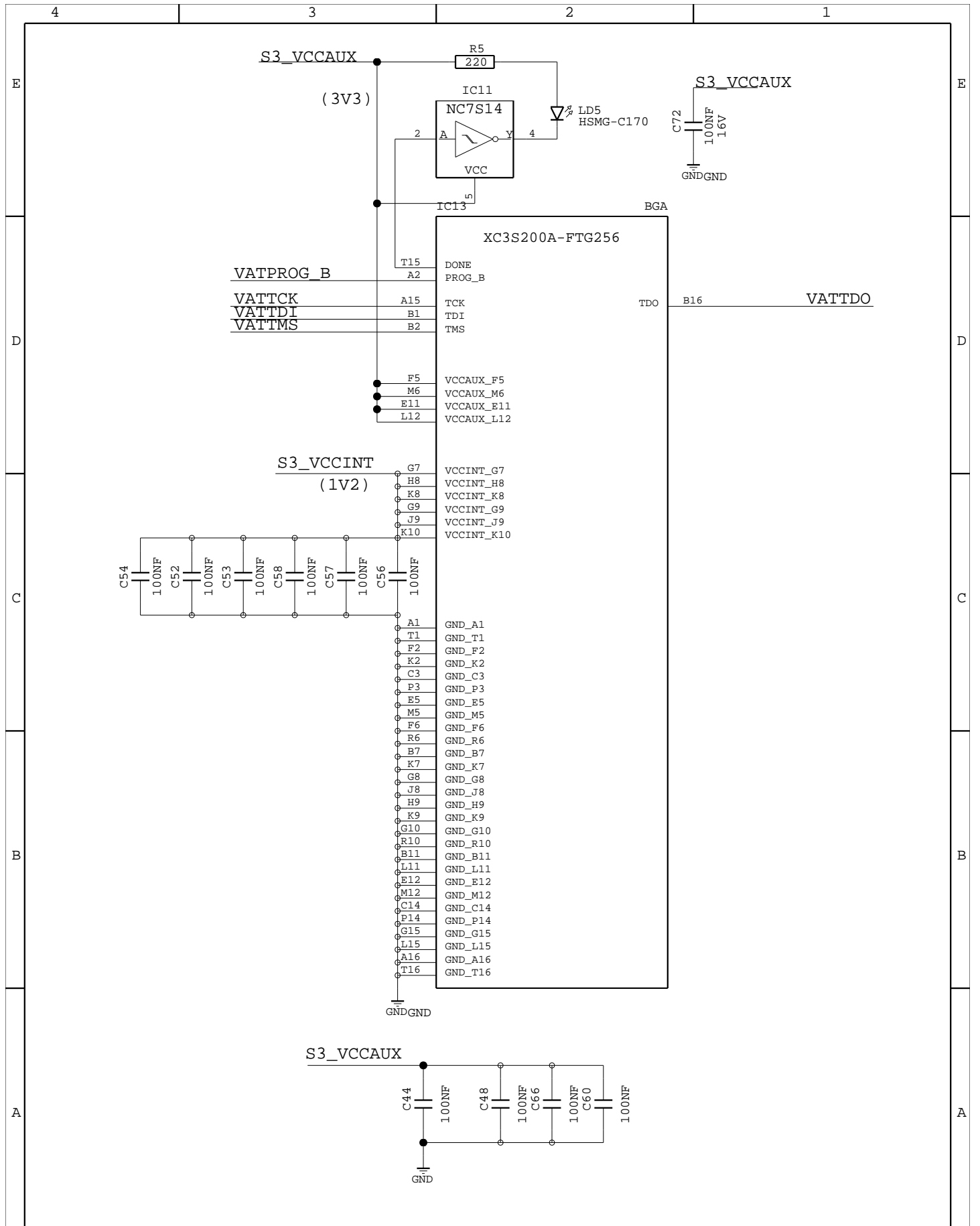

Project file: cmx_vme_vat.cpm

SYSTEM: SPB 16.3

EDA-02515-V1-0

PROJECT: CMX VME Testboard



European Organization
for Nuclear Research
1211 GENEVA 23
SWITZERLAND

MODULE: cmx_vme_vat

Sheet: 6/15 / Project: 6/15

LAST_MODIFIED=Wed May 23 16:20:52 2012

Design by: Y. Ermoline

PCB by: <PCB_BY>

DATE: 11/04/2012

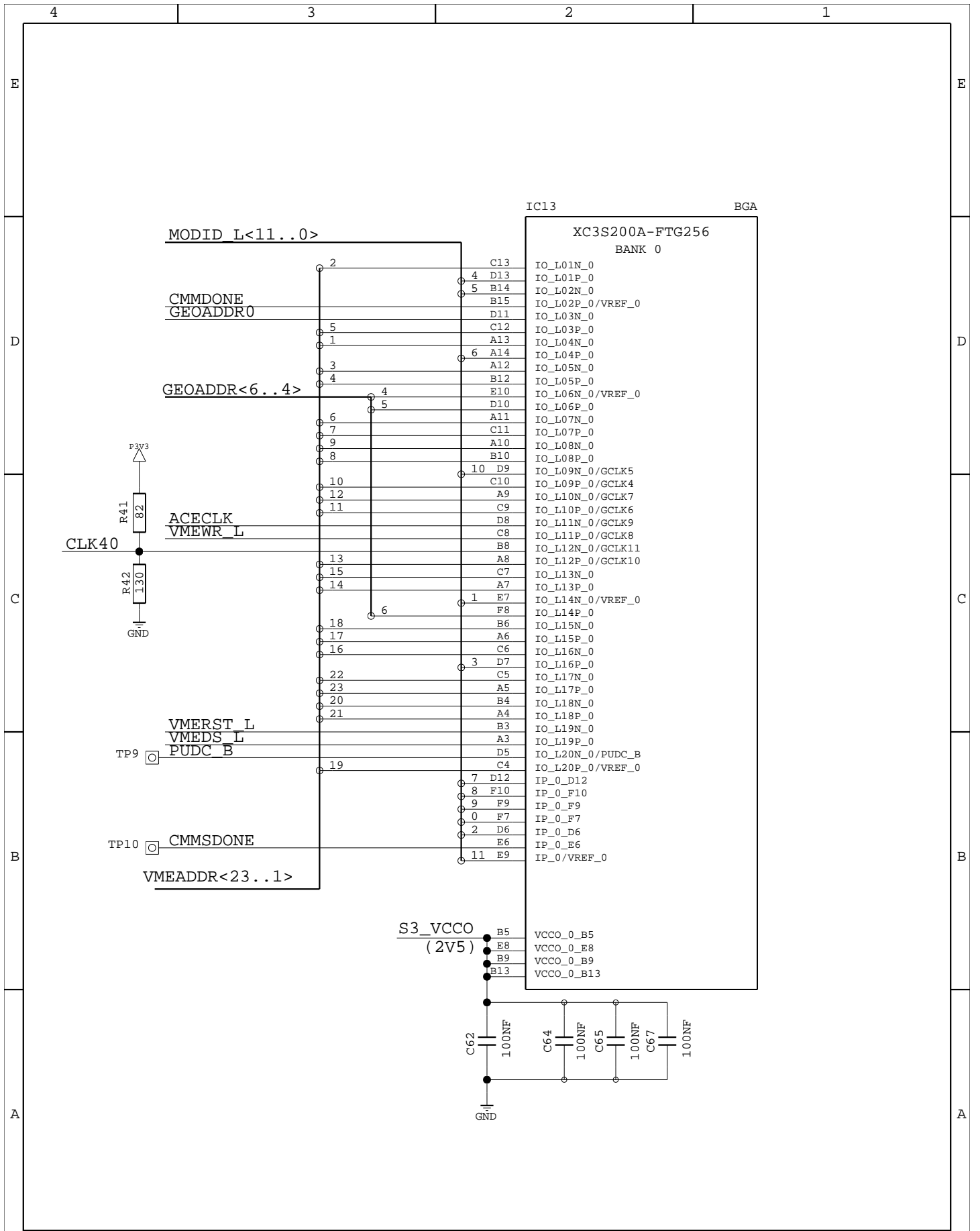

Project file: cmx_vme_vat.cpm

SYSTEM: SPB 16.3

EDA-02515-V1-0

PROJECT: CMX VME Testboard



European Organization
for Nuclear Research
1211 GENEVA 23
SWITZERLAND

MODULE: cmx_vme_vat

Sheet: 7/15 / Project: 7/15

LAST_MODIFIED=Wed May 23 16:20:55 2012

Design by: Y. Ermoline

PCB by: <PCB_BY>

DATE: 11/04/2012

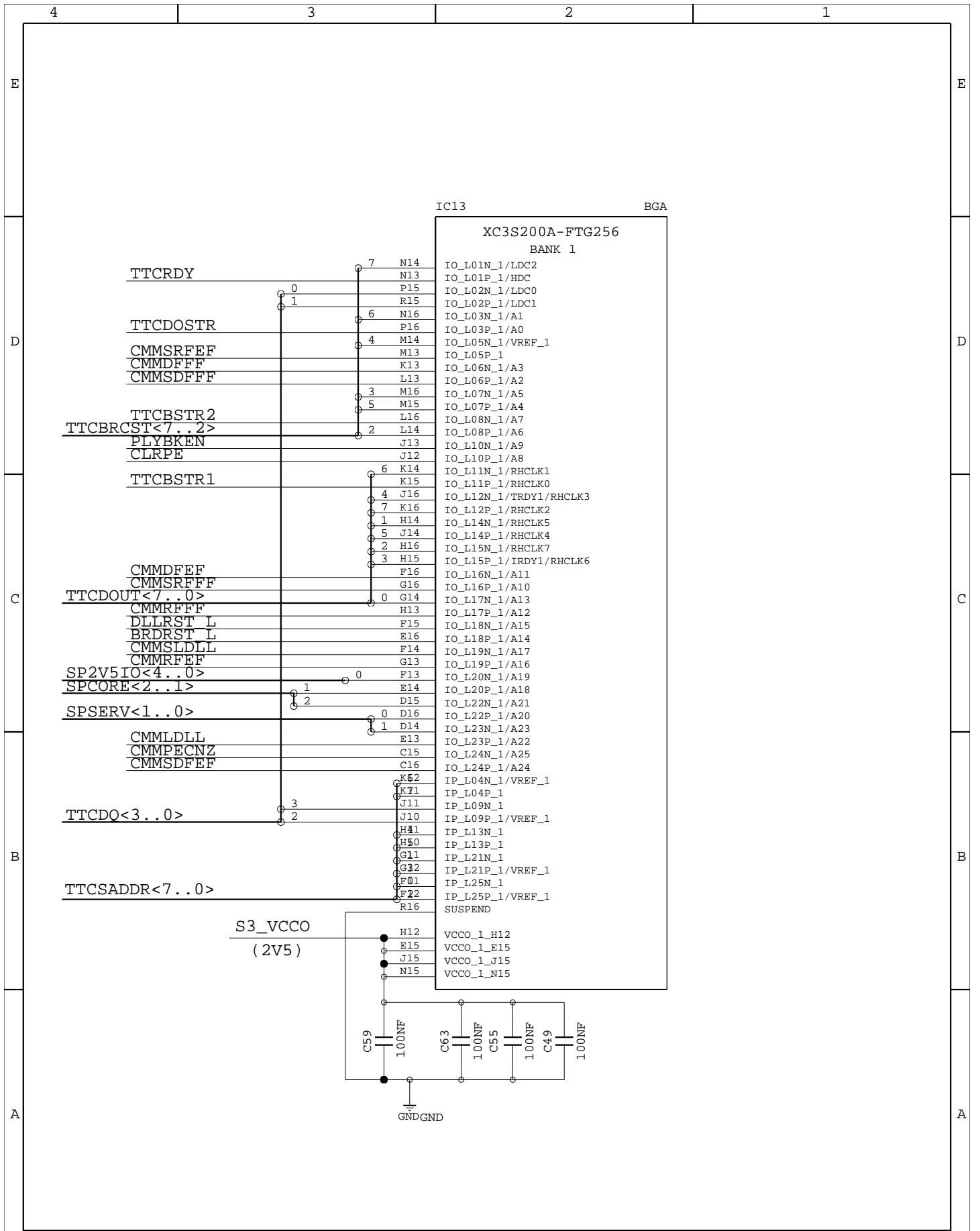

Project file:cmx_vme_vat.cpm

SYSTEM: SPB 16.3

EDA-02515-V1-0

PROJECT:CMX VME Testboard

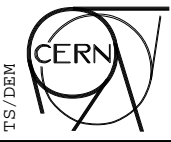

European Organization
for Nuclear Research
1211 GENEVA 23
SWITZERLAND

MODULE:cmx_vme_vat

Sheet: 8/15 / Project: 8/15

LAST_MODIFIED=Wed May 23 16:20:56 2012

Design by: Y. Ermoline

PCB by: <PCB_BY>

DATE: 11/04/2012

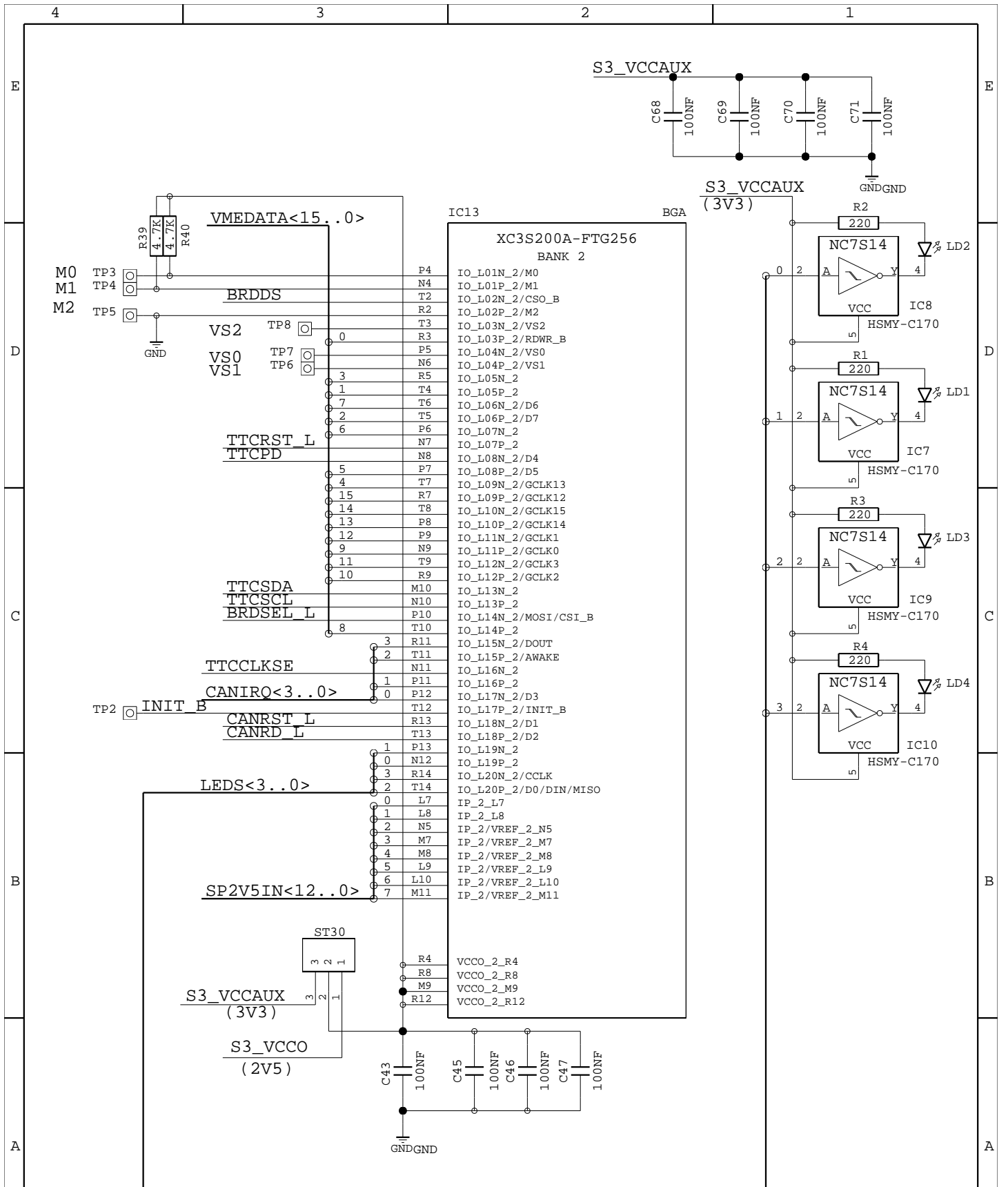

Project file:cmx_vme_vat.cpm

SYSTEM: SPB 16.3

EDA-02515-V1-0

PROJECT:CMX VME Testboard



European Organization
for Nuclear Research
1211 GENEVA 23
SWITZERLAND

MODULE:cmx_vme_vat

Sheet: 9/15 / Project: 9/15

LAST_MODIFIED=Wed May 23 16:20:52 2012

Design by: Y. Ermoline

PCB by: <PCB_BY>

DATE: 11/04/2012

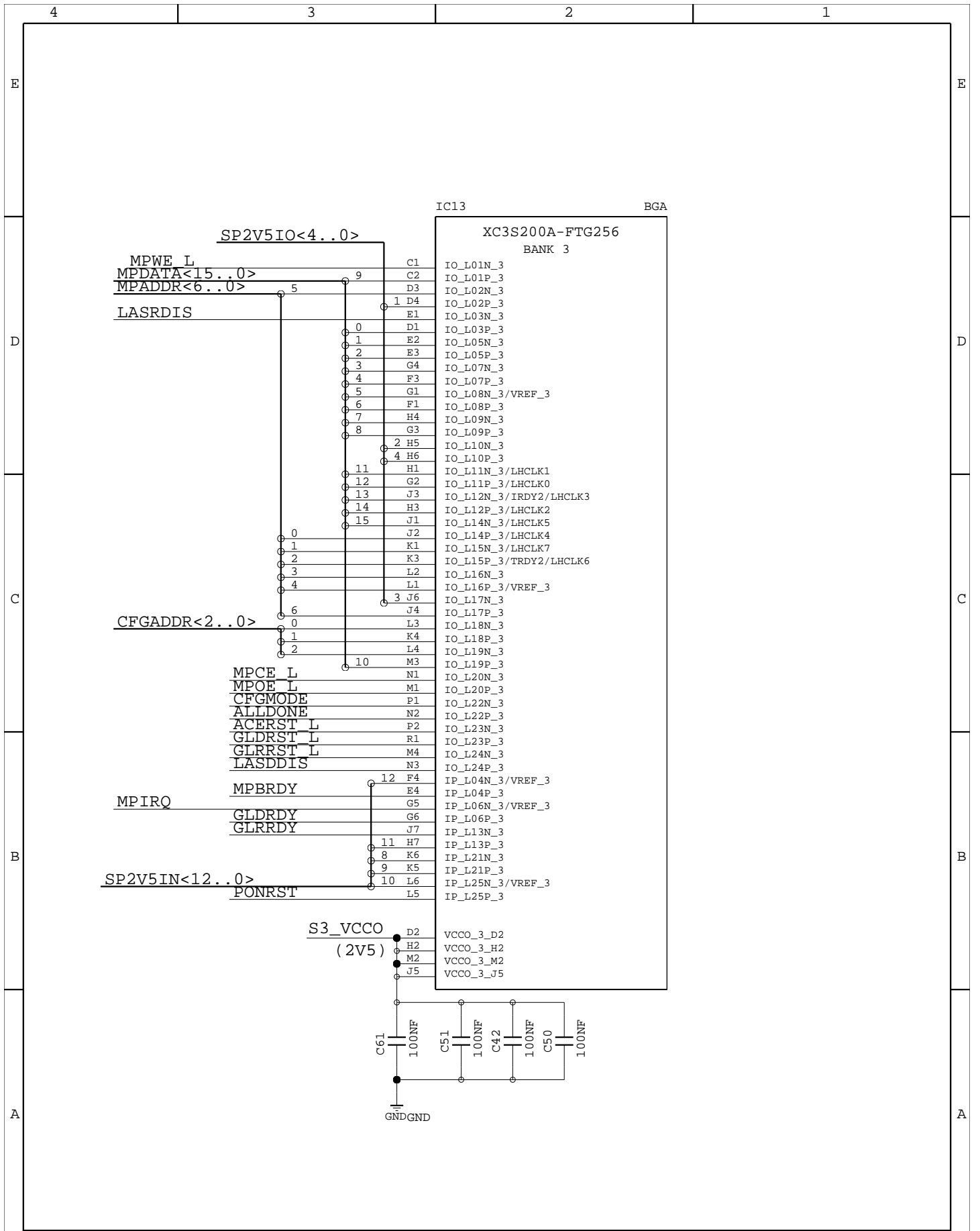

Project file: cmx_vme_vat.cpm

SYSTEM: SPB 16.3

EDA-02515-V1-0

PROJECT: CMX VME Testboard



European Organization
for Nuclear Research
1211 GENEVA 23
SWITZERLAND

MODULE: cmx_vme_vat

Sheet: 10/15 / Project: 10/15

LAST_MODIFIED=Wed May 23 16:20:55 2012

Design by: Y. Ermoline

PCB by: <PCB_BY>

DATE: 11/04/2012

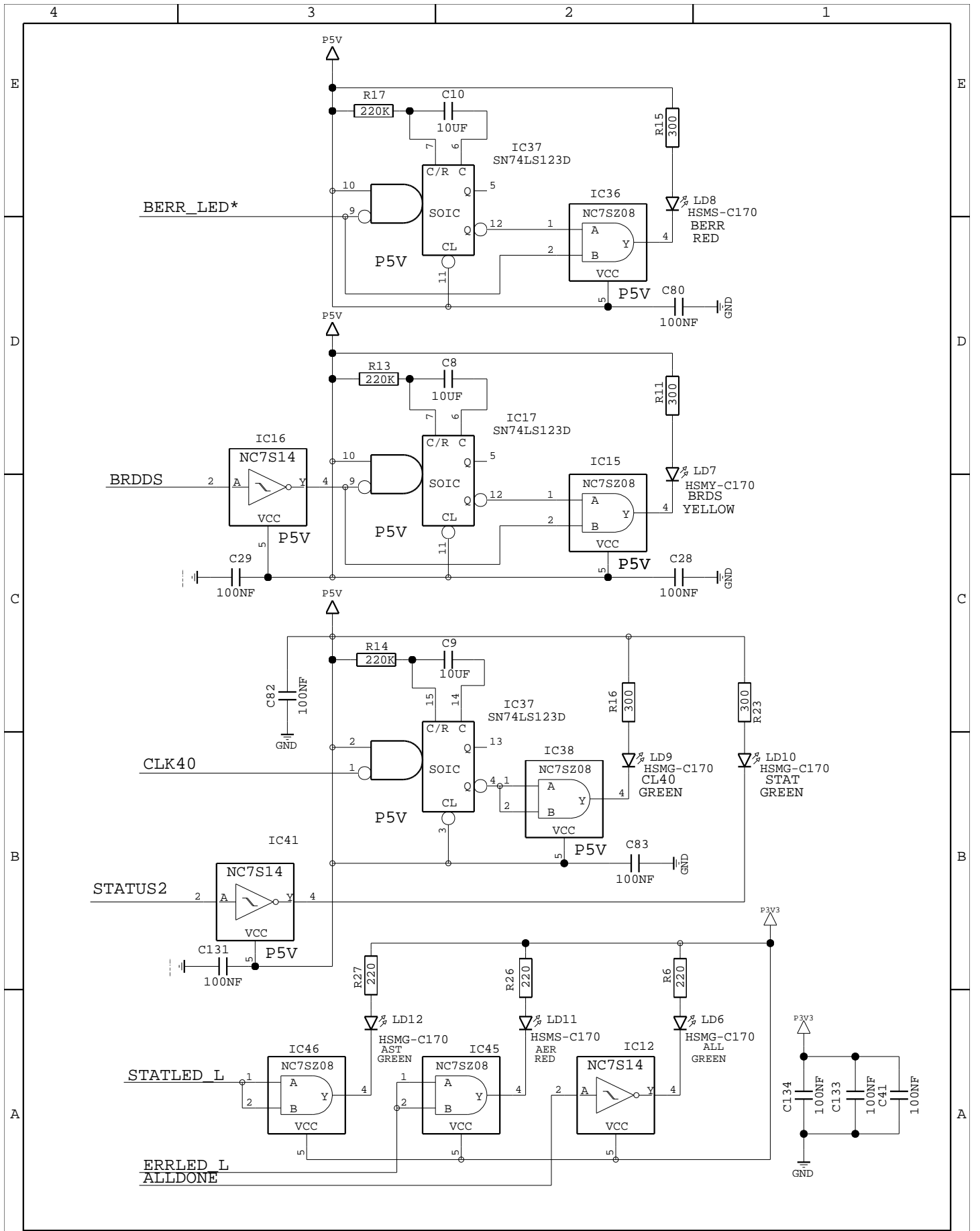

Project file: cmx_vme_vat.cpm

SYSTEM: SPB 16.3

EDA-02515-V1-0

PROJECT: CMX VME Testboard

MODULE: cmx_vme_vat

Sheet: 11/15 / Project: 11/15

LAST_MODIFIED=Wed May 23 16:20:54 2012

Design by: Y. Ermoline

PCB by: <PCB_BY>

DATE: 11/04/2012



European Organization
for Nuclear Research
1211 GENEVA 23
SWITZERLAND

TS/DEM

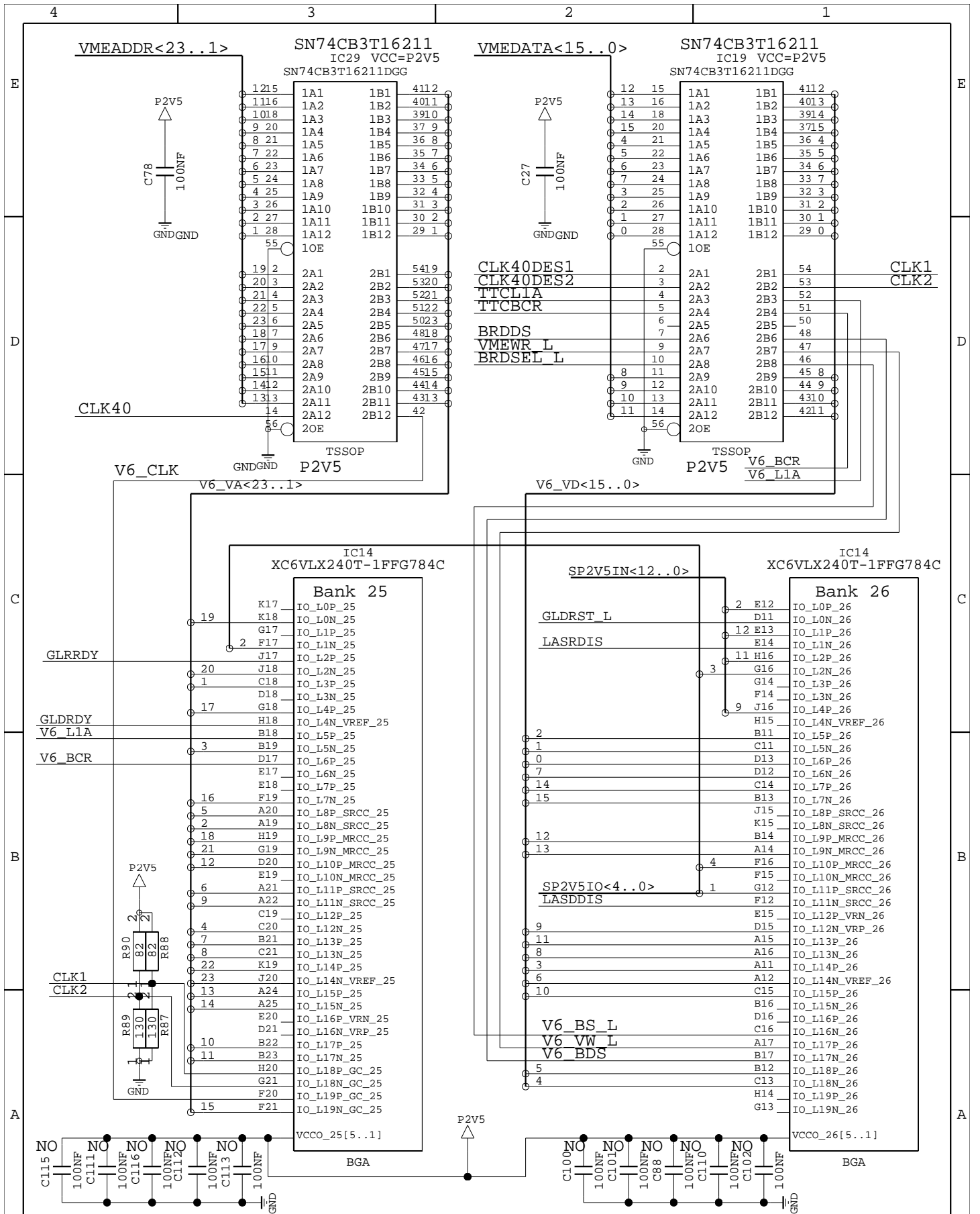

Project file:cmx_vme_vat.cpm

SYSTEM: SPB 16.3

EDA-02515-V1-0

PROJECT:CMX VME Testboard



European Organization
for Nuclear Research
1211 GENEVA 23
SWITZERLAND

MODULE:cmx_vme_vat

Sheet: 12/15 / Project: 12/15

LAST_MODIFIED=Wed May 23 16:20:54 2012

Design by: Y. Ermoline

PCB by: <PCB_BY>

DATE: 11/04/2012

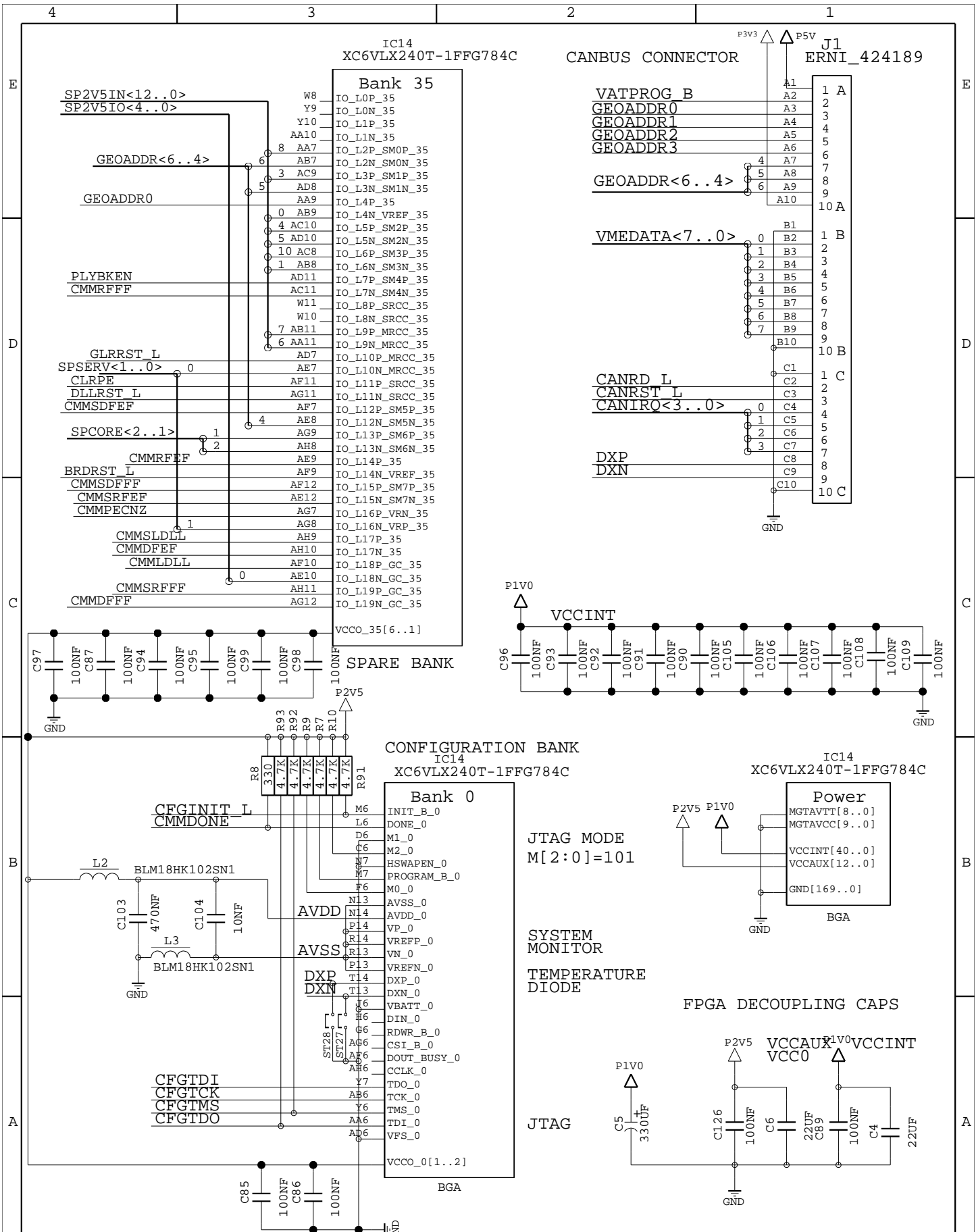

Project file: cmx_vme_vat.cpm

SYSTEM: SPB 16.3

EDA-02515-V1-0

PROJECT: CMX VME Testboard

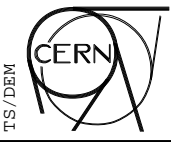

European Organization
for Nuclear Research
1211 GENEVA 23
SWITZERLAND

MODULE: cmx_vme_vat	Sheet: 13/15	Module: / Project: 13/15
LAST_MODIFIED=Wed May 23 16:20:53 2012		
Design by: Y. Ermoline	PCB by: <PCB_BY>	DATE: 11/04/2012

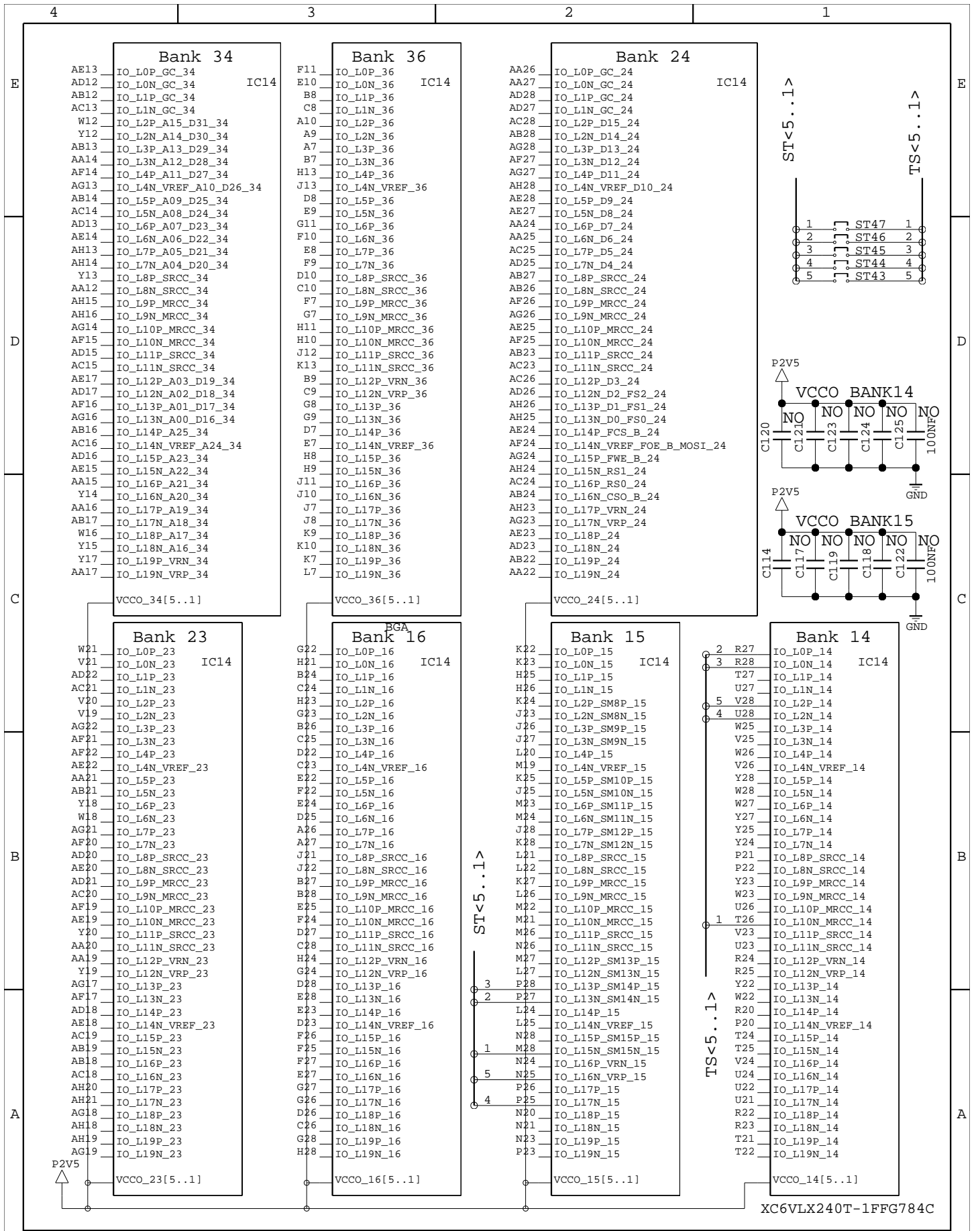

Project file:cmx_vme_vat.cpm

SYSTEM: SPB 16.3

EDA-02515-V1-0

PROJECT:CMX VME Testboard

MODULE:cmx_vme_vat

Sheet: 14/15 / Project: 14/15

LAST_MODIFIED=Wed May 23 16:20:55 2012

Design by: Y. Ermoline

PCB by: <PCB_BY>

DATE: 11/04/2012

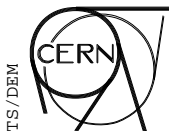

European Organization
for Nuclear Research
1211 GENEVA 23
SWITZERLAND

TS/DEM

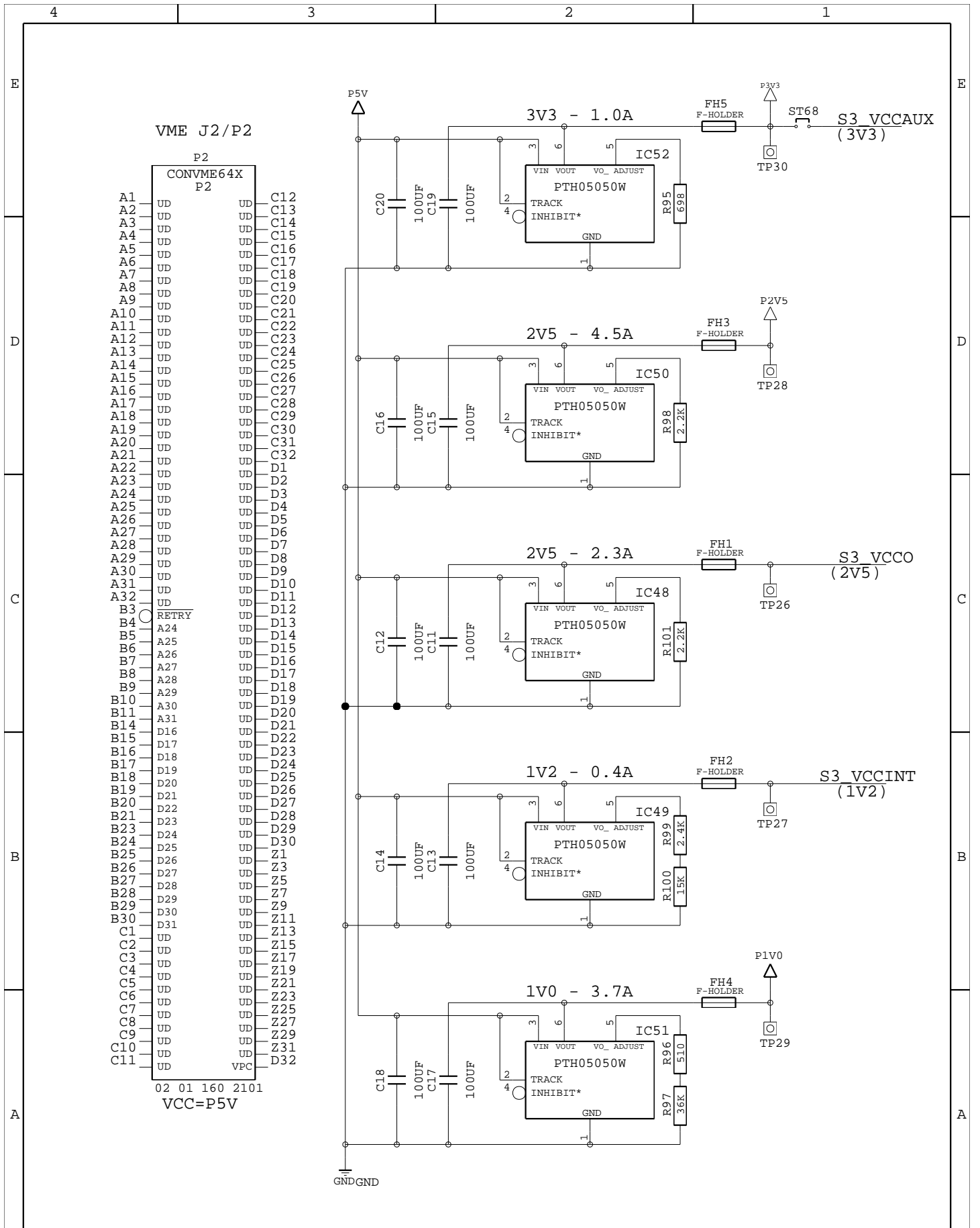

Project file:cmx_vme_vat.cpm

SYSTEM: SPB 16.3

EDA-02515-V1-0

PROJECT:CMX VME Testboard



European Organization
for Nuclear Research
1211 GENEVA 23
SWITZERLAND

MODULE:cmx_vme_vat

Sheet: 15/15 / Project: 15/15

LAST_MODIFIED=Wed May 23 16:20:51 2012

Design by: Y. Ermoline

PCB by: <PCB_BY>

DATE: 11/04/2012