



Reference Guide to Fiber Optic Testing

Glossary



Reference Guide to Fiber Optic Testing

Glossary

By

Laurence Choquet

Contact the author

JDSU

34 rue Necker

42000 Saint-Etienne

France

Tel. +33 (0) 4 77 47 89 00

Fax +33 (0) 4 77 47 89 70

This Glossary is a companion to the *JDSU Reference Guide to Fiber Optic Testing*. Visit jdsu.com/fibertest to view the complete series of educational resources on fiber optic principles and testing available from JDSU.

Table of Contents

Section 1: Terms and definitions

A-C 2
D-F 18
G-Q 37
R-Z 59

Section 2: Acronyms and Abbreviations 76



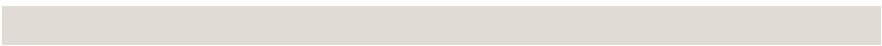

Terms and definitions

Section 1

A

Absorption

A power loss mechanism occurring in an optical fiber, due to molecular resonance and impurities which convert optical power to heat.

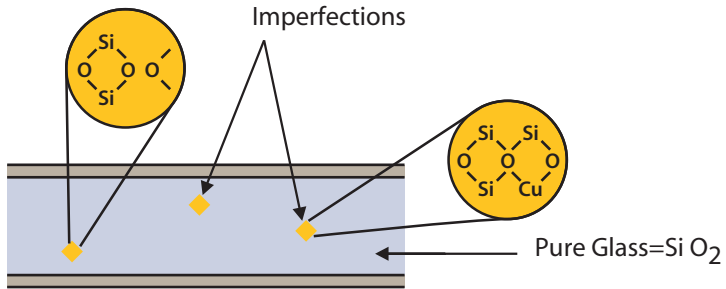

Acceptance Angle

The maximum angle to the axis of the fiber allowing light to be reflected and consequently propagated through the fiber. Light entering with a larger angle is refracted. *Note: Applies only to multimode fiber. See Numerical Aperture (NA).*

Add/Drop Multiplexer (ADM)

An element of optical fiber networks that allows adding or dropping a channel within a wavelength division multiplexer (WDM) transmission.

ADMs can be used both in long-haul core networks and in shorter-distance metro networks. The main optical filtering technology used in add-drop multiplexers is the Fabry-Pérot etalon.

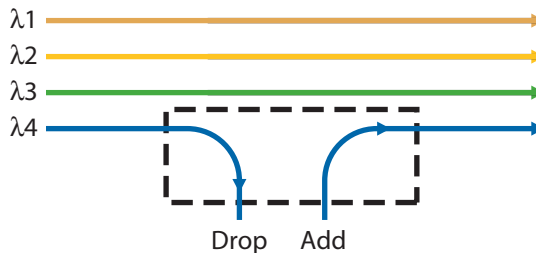

Amplified Spontaneous Emission (ASE)

Light, produced by spontaneous emission(1), that has been optically amplified by the process of stimulated emission(2) in a gain medium.

(1) Spontaneous emission is the process by which an atom, molecule or nucleus in an excited state drops to a lower-energy state, resulting in the creation of a photon.

(2) Stimulated emission is the process by which, when perturbed by a photon, matter may lose energy resulting in the creation of another photon. The perturbing photon is not destroyed in the process, and the second photon is created with the same phase, frequency, polarization, and direction of travel as the original.

In case of an intense use of cascaded EDFAs, this phenomenon can cause important disturbances. Generated photons taking the same direction than the optical signal will be amplified and, therefore, will add noise in the system.

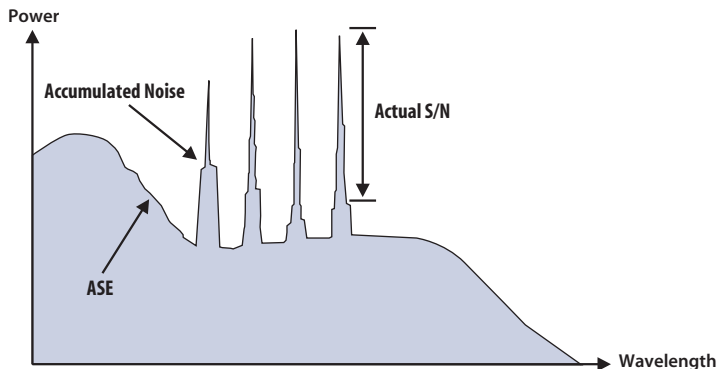

Amplifier (Optical)

A device that strengthens an optical signal. Optical fibers doped with erbium (EDFA) are an example.

Angled Physical Contact (APC)

A type of fiber connector that minimizes backreflection due to a 5°-15° angle-polish applied on end faces.

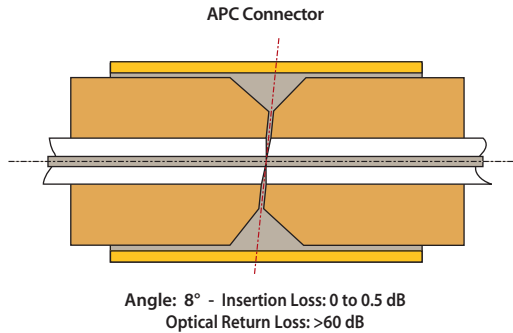

Angular Misalignment Loss

Power loss caused by the deviation from optimum alignment of source to fiber, fiber to fiber, or fiber to detector.

Armored Cable

A fiber cable that includes a layer of corrugated steel to prevent rodent ingress. Primarily for direct buried applications, occasionally used in aerial applications where squirrels are a severe problem.

Arrayed Waveguide Grating (AWG)

A device that allows multiple wavelengths to be combined and separated (multiplexed and demultiplexed) in a dense wavelength-division multiplexing (DWDM) system.

Attenuation

Reduction in optical signal (amplitude and intensity) as it propagates along a fiber. Attenuation is due to absorption, scattering and other loss mechanisms (such as impurities, bending, and coupling). Usually expressed in dB or as a rate of loss per unit distance (dB/km).

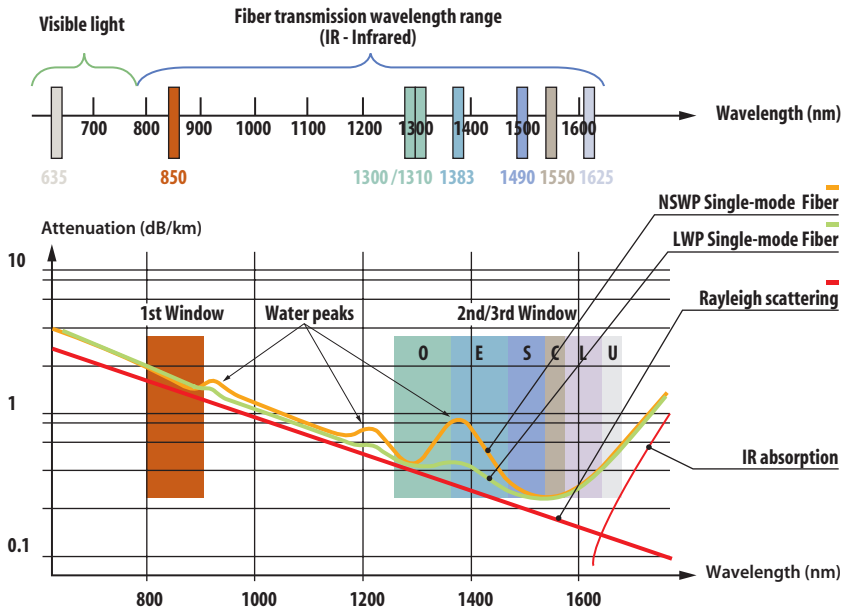

Attenuation Coefficient

A coefficient characterizing the attenuation of an optical fiber per unit of length (dB/km). This coefficient corresponds to the rate of optical power loss with respect to distance along the fiber.

Attenuation Dead Zone (ADZ)

Minimum distance for an OTDR to detect a non-reflective event (for example, splice) following a reflective event. The attenuation dead zone depends on the pulse width, the reflectance, the loss, the displayed power level and the location.

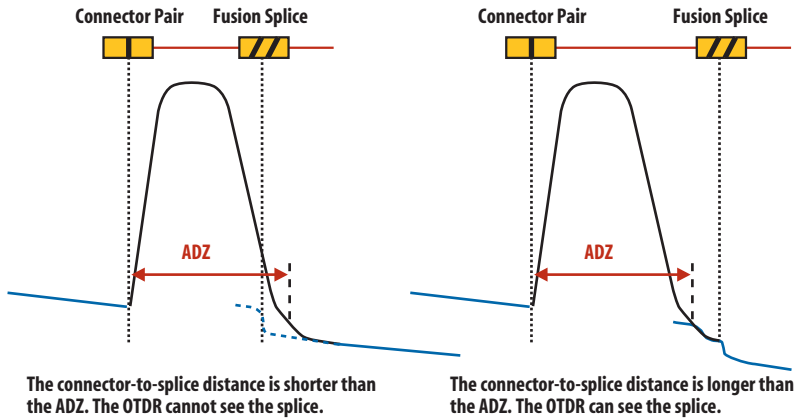

Attenuation-Limited Operation

The condition when operation is limited by the received signal power rather than by bandwidth or distortion.

Attenuator

A passive device that induces power loss to reduce the amplitude of a signal without generating distortion.

Avalanche Photodiode (APD)

A photodiode that produces internal amplification of the signal due to the multiplication of charge carriers in the p-n junction region.

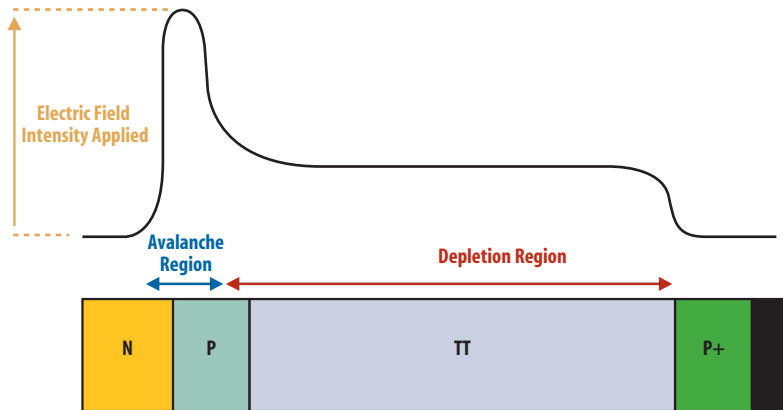

APD Schematic with Electric Field Intensity

B

Back Reflection (BR)

The power reflected back toward the source from any event or device in the optical link (fiber ends, fiber deformations, and connectors). Also called Fresnel reflection.

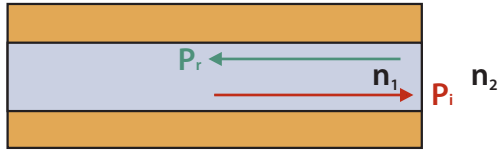

Backscattering

Scattered light that returns back toward the source.

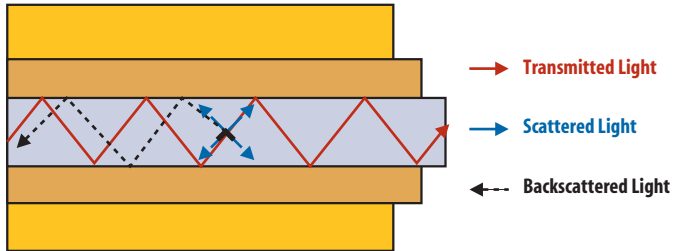

Bandpass (Optical)

The range of optical wavelengths that are transmitted through a component.

Bandwidth (BW)

Range of frequencies, expressed in hertz (Hz) within which the fiber can carry information.

Beam Splitter

An optical device that splits a beam of light into several beams, transmitting specified wavelength and reflecting others.

Bend Radius (minimum)

The radius a fiber can bend before increased loss or mechanical damage occurs.

BER Test Set

Bit/block error rate (BER) testing is a technique used to determine the quality of communication links. This technique consists of transmitting a known bit pattern through a communication link and determining the average fraction of wrongly transmitted bits.

Bit Error Rate (BER)

The average fraction of wrongly transmitted bits in a communication link. The BER of a system for optical fiber communications can be increased by noise influences, optical losses, dispersion, and nonlinearities.

Birefringent

Having a refractive index that is light polarization-dependent.

Birefringence

The decomposition of a light beam into two diverging beams (ordinary and extraordinary) when passing through a material with a refractive index depending on the light polarization (such as fibers). Also called double refraction.

Bragg Grating

[See Fiber Bragg Grating.](#)

Broadband

Refers to the capability for a network to offer a wide band of frequencies available to transmit information, which allows signal multiplexing and high data rates.

Buffer

In optical fiber, a protective coating applied directly to the fiber.

Buffer Tube

A thermoplastic tube that holds a bundle of fibers and that contributes to the decrease of the mechanical constraints applied to fibers.

C

Cable

A structure carrying multiple fibers, usually more than 4 (fewer than 4 fibers is referred to as “CORD”) that provides mechanical and environmental protection, tensile strength, and fire resistance.

Typical fiber cables are described below:

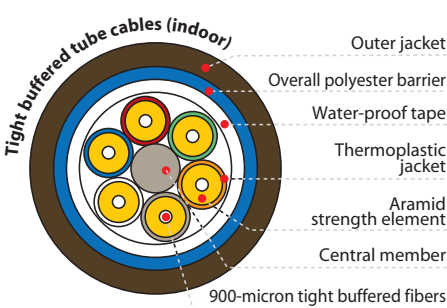

Applications: Computer rooms, telecommunications central offices, tunnels and confined areas, riser shafts.

Tight buffered tube cable can hold from 1 to 12 fibers per tube (up to 200 fibers in one cable).

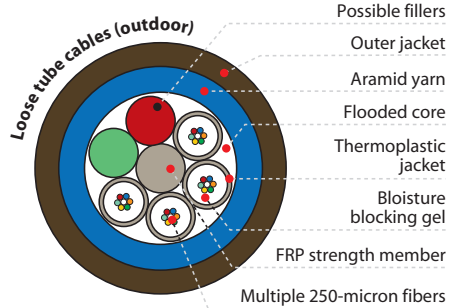

Applications: Building interconnections, telecommunications and data trunks, long haul networks, and ducts between buildings.

Applications requiring moisture and weather resistance. Loose tube cable can hold from 1 to 12 fibers per tube (up to 200 fibers).

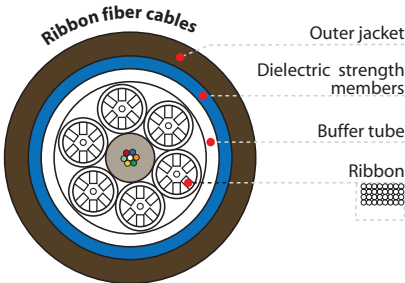

Typical applications: equipment interconnects, high speed data transfer, premises networks.

Ribbon cables can hold 204 fibers in a 0.5-inch cable. This picture shows a 3000 fiber underground cable.

Cable Plant

All optical elements installed between a transmitter and a receiver, including fiber, connectors, and splices.

Carrier-to-Noise Ratio (C/N)

A measure of the received carrier strength relative to the strength of the received noise. High C/Ns provide better quality reception, and generally higher communications accuracy and reliability, than low C/Ns.

CD Analyzer

A device used to measure the level of chromatic dispersion (CD) present on an optical link.

Central Wavelength (Laser)

In laser diodes, the average of the two wavelengths measured at the half amplitude points of the power spectrum, corresponding to the full width half maximum (FWHM).

% of Spectral Emission

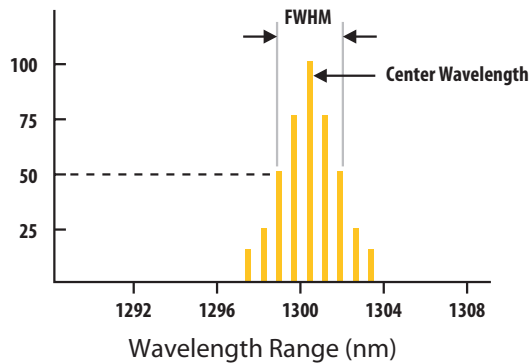

Channel (Optical)

In a DWDM system, a channel is a communication path characterized by a wavelength slightly different from the adjacent channels. See [Channel Spacing](#).

Channel Spacing (Optical)

In a DWDM system, the wavelength step between two adjacent channels, expressed in GHz.

Channel Width (Optical)

Wavelength range of a channel, expressed in nm.

Chirp

An abrupt shift of the center wavelength of a laser during a single pulse, due to laser instability

Chromatic Dispersion (CD)

A phenomenon that causes a spread of light pulses traveling into the fiber. CD is due to the fact that the refractive index of the material constituting a fiber is wavelength-dependant. Thus, shorter wavelengths travel faster than longer ones. As a light pulse is never perfectly monochromatic, pulses spread in time and may overlap with their neighbors until they become indistinguishable, which is when bit errors may occur.

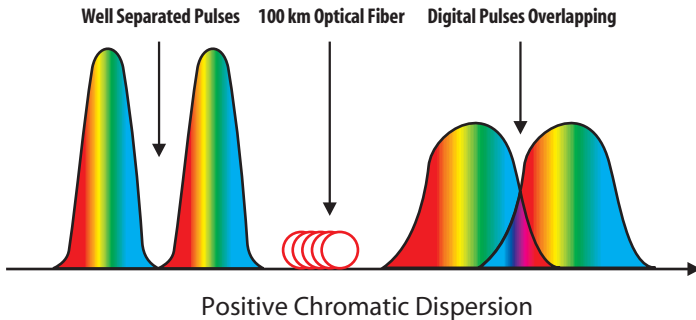
**Circulator**

A passive component composed of three or four ports that couple signal from one port (n) to the next port ($n+1$), the first port being counted as following the last one. Note that the port n is isolated from signals in port $n+1$.

Cladding

A glass layer surrounding the core of an optical fiber. The lower refraction index of the cladding as compared to the core allows the transmitted light to be reflected and guided along the core.

See also [Core](#).

Cladding Mode

An undesired light ray (mode) that propagates in the cladding.

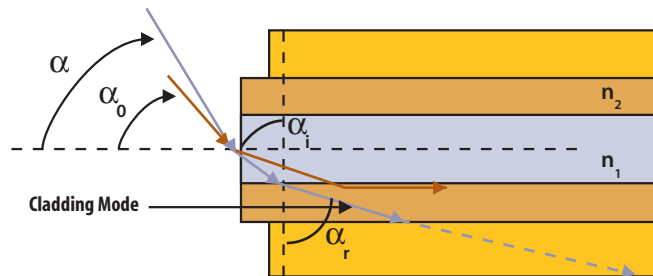

Coarse Wavelength Division Multiplexing (CWDM)

CWDM is a method of combining multiple signals at various wavelengths for transmission along fiber optic cables, such that the number of channels is fewer than in dense wavelength division multiplexing (DWDM) but more than in standard wavelength division multiplexing (WDM).

CWDM systems have channels at wavelengths spaced 20 nm apart, compared with 0.4 nm spacing for DWDM.

Coating

A plastic overcoat covering the cladding layer of a fiber to protect the glass surface. See also [Core](#)

Composite Power

The sum of the power level of each carrier of a DWDM system.

Concentricity

The measurement of how well-centered the core is within the cladding.

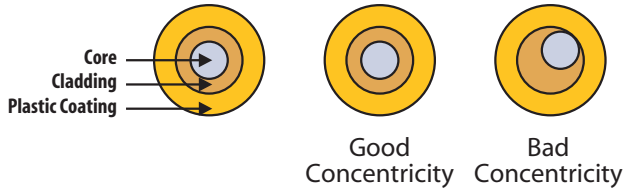

Connector

A junction allowing two sections of optical fiber to be connected together or to an optical device such as a source or a receiver.

These connectors are usually of a standard type such as FC, SC, ST, LC, or DIN. Each type comes with particular characteristics, advantages and disadvantages, and different performance parameters.

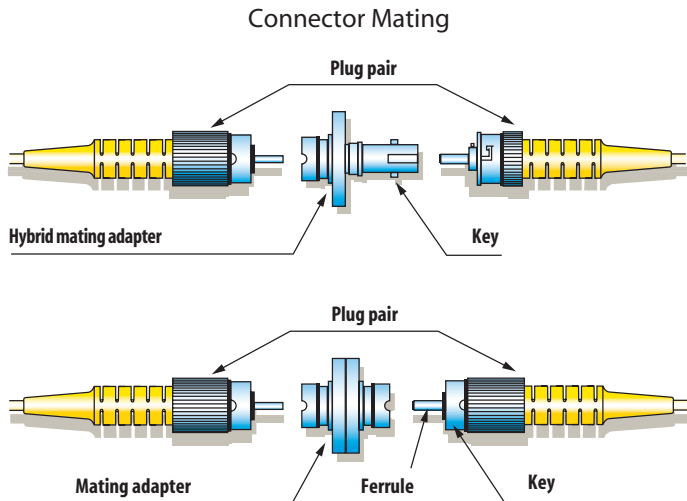

Continuous Wave (CW)

State for a source where the emitted power is constant (not modulated).

Conventional Band (C-Band)

A transmission band for wavelength from 1530 to 1565 nm. Also called third window. See also [Transmission Band](#).

Core

A transparent central region of an optical fiber, made of nearly pure silicon dioxide (SiO_2), through which the light travels. The core is surrounded by a cladding layer that reflects light, guiding the light along the core. A plastic coating covers the cladding to protect the glass surface.

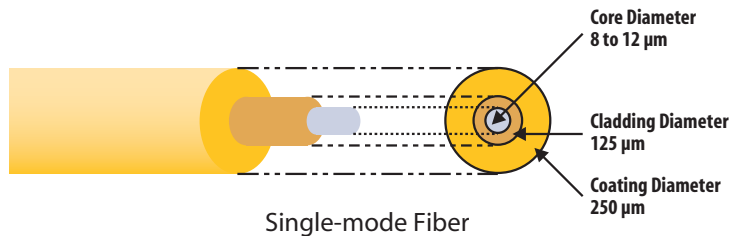

Coupler

An optical device that combines or splits light from other optical devices. Different families of couplers exist (for example: X coupler, Y coupler, or Star coupler).

Couplers are the basis of optical cross-connects.

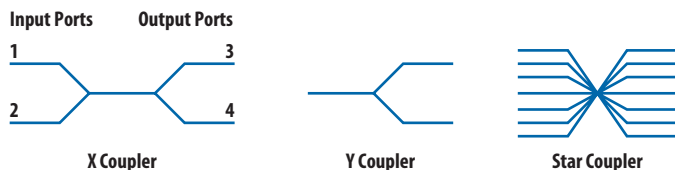

Coupling Ratio/Loss (CR, CL)

The ratio/loss of optical power from one output port to the total output power. Expressed as a percentage.

Cross-Connect (XC)

See Optical Cross-Connect.

Cross-Phase Modulation (XPM)

Cross-phase modulation is the change of the phase of a signal caused by the interaction with another signal. This phenomenon is due to nonlinear optical effect occurring in fiber (called Kerr effect) and causing a change of refractive index.

Crosstalk (XT)

An undesired coupling from one channel to another.

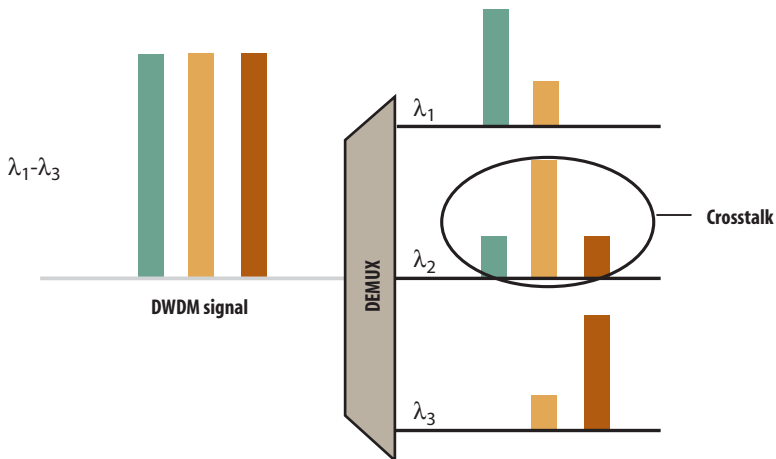
**Cutback Method**

A technique to measure the attenuation of an optical fiber by comparing the optical power transmitted through a fiber to the power transmitted by a short section of the same fiber.

Cutoff Wavelength

The wavelength beyond which a single-mode fiber carries only one mode.

D

Dark Current

The current that flows in a photodetector when it is not receiving light at its input, which can be considered noise.

Dead Zone

Distance section on OTDR traces, which is observable after each reflective event and which represents the distance between the beginning of the event and the end of a period where a consecutive event cannot be detected. See also [Event Dead Zone \(EDZ\)](#) and [Attenuation Dead Zone \(ADZ\)](#).

Decibel (dB)

Unit used to express values of power level on a logarithmic scale. The power level is always relative to a reference power P_0 :

$$L_{P/P_0} = 10 \cdot \log_{10}(P/P_0) \text{ dB}$$

where P and P_0 are expressed in the same linear units.

Also commonly found:

dBc: decibel relative to a carrier level

dB μ : decibel relative to microwatt

dBm: decibel relative to milliwatt

Demultiplexer (Demux)

A device that splits two or more signals previously combined.

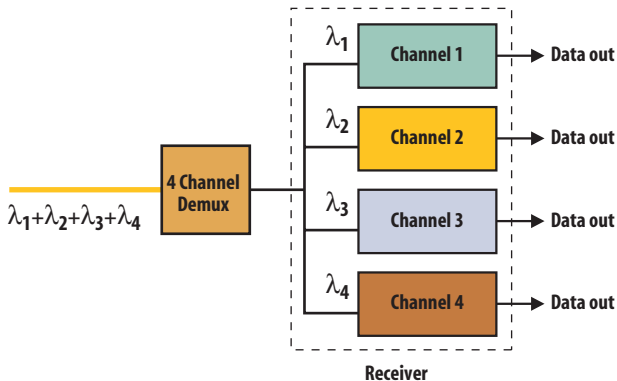

Dense Wavelength Division Multiplexing (DWDM)

A technique used to multiplex several signals on a single fiber within a narrow wavelength band.

Detector

An opto-electric component for converting optical power to electrical current. Usually refers to a photodiode.

Device Under Test (DUT)

Refers to the device being measured by some type of test equipment.

Diameter-Mismatch Loss

Power loss occurring when the transmitting fiber diameter is greater than the receiving fiber diameter. This loss may occur when coupling a source to fiber, fiber to fiber, or fiber to detector.



Dichroic Filter

A very accurate color filter used to selectively pass light of a small range of wavelengths, whereas other ones are reflected. Used in wavelength division multiplexers (WDM).

Diffraction Grating

An optical component that splits light into different wavelength, using the diffraction effect. Its surface is covered by a regular pattern of parallel lines, typically separated from a distance comparable to the wavelength of light.

Diffraction gratings are often used in spectrometers and wavelength division multiplexing devices.

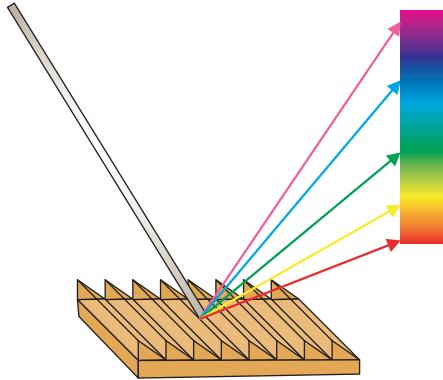

Diode

An electronic device that allows current flow in only one direction, for example, LEDs, laser diodes, and photodiodes.

Dispersion

The temporal spreading of a signal caused by light signals traveling at different speeds either due to modal, chromatic, or polarization effects.

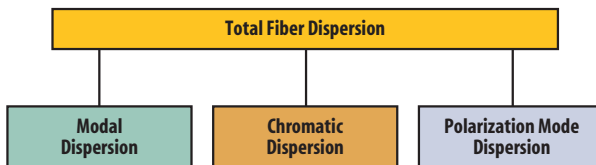

Dispersion-Compensating Fiber (DCF)

A fiber used to cancel the chromatic dispersion effects, due to its opposite dispersion of the fiber being used in the transmission system.

Dispersion-Compensating Unit or Module (DCU or DCM)

A module that has the opposite dispersion of the fiber being used in a transmission system, which offsets the effects of chromatic dispersion.

Dispersion Management

A technique used to significantly reduce the dispersion introduced by the optical fiber and consequently to improve system performance. A dispersion slope compensator is an example of dispersion management technique.

Dispersion-Shifted Fiber (DSF)

A type of single-mode fiber designed to have zero dispersion near 1550 nm. This fiber type is not suitable for DWDM applications, due to its high nonlinearity at the zero-dispersion wavelength. These fibers have been normalized by the ITU as G.653.

Dispersion Supported Transmission (DST)

In optical time division multiplexing (OTDM) systems, a transmission system that allows data rates at 40 Gb/s by incorporating devices such as semiconductor optical amplifiers (SOAs).



Distributed Feedback Laser (DFB)

An injection laser diode built with a Bragg reflection grating in the active region in order to avoid multiple longitudinal modes and enhance a single longitudinal mode.

DFB lasers are often used in DWDM communication where a tunable laser signal is desired.

It produces a finer range of wavelengths than a Fabry-Perot laser, which emits a lot of harmonics between 5 and 8 nm and cannot be used in WDM systems.

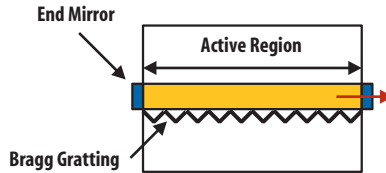

Distribution System

Part of a cable system used to carry signals from the headend to subscriber terminals.

Dominant Mode

In a waveguide that can support more than one propagation mode, the mode that propagates with minimal degradation, or the mode with the most power.

Dopant

A substance, such as Erbium in EDFAs, added to a material to change its optical properties.

Duplex Cable

A two-fiber cable suitable for duplex transmission.

Duplex Transmission

Bidirectional transmission, either in one direction at a time (simple or half-duplex), or in both directions simultaneously (full-duplex).

DWDM Multiplexer/Demultiplexer

Devices that are used to combine (multiplexer) several channels (several wavelengths) on a single fiber or to split a multi-wavelength signal into several different signals (demultiplexer).

In most of cases, such a device performs both multiplexing and demultiplexing.

Dynamic Range

One of the most important characteristics of an OTDR that determines the maximum observable length of a fiber and, therefore, the OTDR suitability for analyzing any particular network. The higher the dynamic range, the higher the signal to noise ratio (S/N) and the better the trace will be, with better event detection.

Depending on the noise level reference, there are many definitions of dynamic range, each providing different values not immediately comparable. Among them:

- IEC Dynamic Range (introduced by Bellcore)

The upper level of the noise is taken as the upper limit of a range, which contains at least 98% of all noise data points. This definition was endorsed by the International Electro-technical Commission (IEC) in document IEC 61746.

- RMS Dynamic Range

The root mean square, also termed SNR=1, dynamic range corresponds to the difference between the extrapolated point of the backscatter trace at the near end of the fiber (taken at the intersection between the extrapolated trace and the power axis) and the RMS noise level.



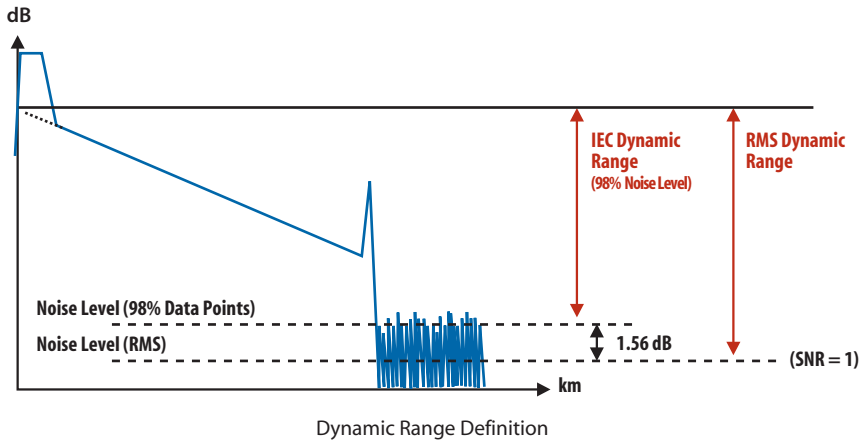

E**Edge-Emitting Diode (ELED)**

An LED that emits light from its edge, producing more directional output than surface-emitting LEDs that emit light from the top surface.

Effective Area

In a single-mode fiber, the area that carries the light.

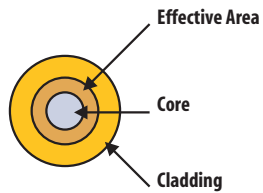

Electromagnetic Spectrum

The range of frequencies of electromagnetic radiation from zero to infinity.

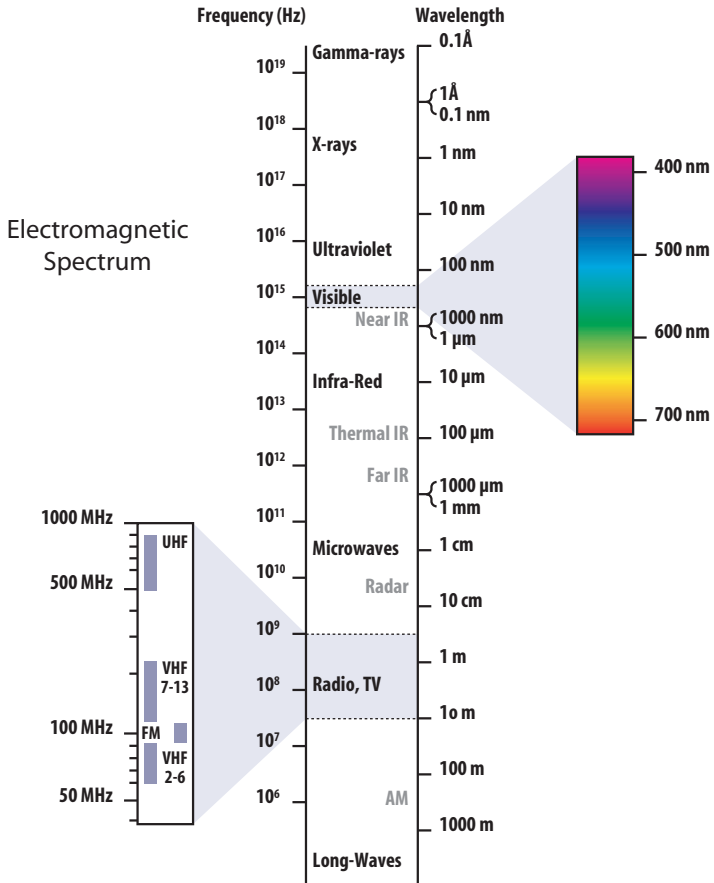

Ellipticity

Describes the fact that the core or cladding is elliptical instead of being circular.

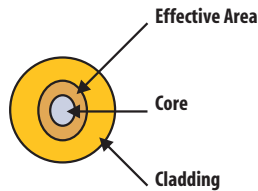

Electrical-to-Optical Converter (E/O).

A device that converts electrical signals to optical signals, such as a laser diode.

Equilibrium Mode Distribution (EMD)

In multimode fibers, a steady state mode distribution. When achieved, the relative power in modes is stabilized and the distribution of light travels in the medium without any disturbance or leakage/gain.

Equilibrium Length

The length of multimode fiber necessary to reach the equilibrium mode distribution for a specific excitation condition. Also called equilibrium coupling length and equilibrium mode distribution length.

Erbium-Doped Fiber Amplifier (EDFA)

An optical amplifier which uses erbium-doped optical fibers to amplify light in the 1550 nm region when pumped by an external light source (a laser at 980 nm or at 1480 nm).

The signal to be amplified and a pump laser are multiplexed into the doped fiber, and the signal is amplified through interaction with the doping erbium ions (Er^{+3}).

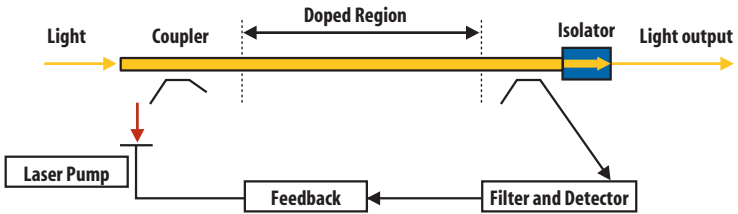

EDFA Principle

Evanescent Wave

Part of light that penetrates into the cladding and propagates through it instead of the core.

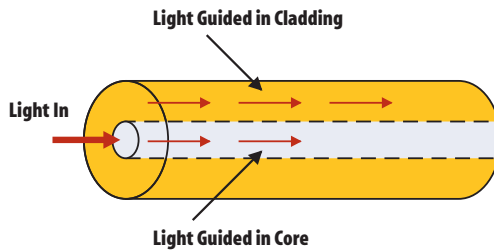

Event Dead Zone (EDZ)

Minimum distance on the OTDR's trace, where two separate events can still be distinguished.

- For a reflective event, the EDZ definition is the distance between the two opposite points which are 1.5 dB (or FWHM) down from the peak. The reflectance of the event shall be specified (as an example Bellcore gives a reflectance of -30 dB).
- For a nonreflective event, the event dead zone definition is the distance between the points where the beginning and ending levels at a splice or a given value (≤ 1 dB) are within ± 0.1 dB of their initial and final values. Usually this dead zone is a fixed value and depends only on the pulsewidth and the fiber.

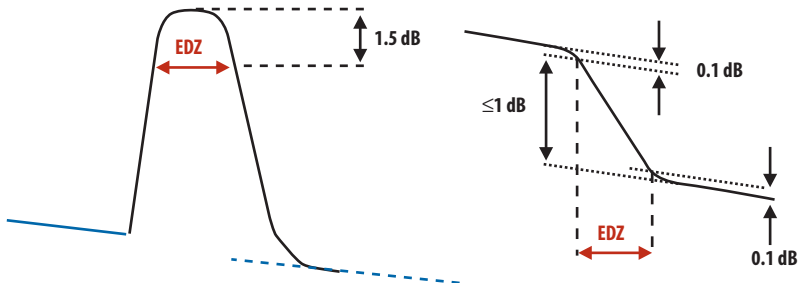

Excess Loss

In a fiber optic coupler, the ratio of the optical power launched at the input port to the total optical power measured from all output ports. This value is expressed in decibels (dB).

Extended Band (E-Band)

A transmission band for wavelength from 1360 to 1460 nm.

See also [Transmission Band](#).

External Modulation

Modulation of a source by an external device acting as an electronic shutter.

Extinction Ratio

The ratio of the low/OFF optical power to the high/ON optical power, expressed as a percentage.

Extrinsic Loss

In a fiber interconnection, the portion of loss due to imperfect joining of a connector or splice.

Eye Pattern

An oscilloscope display that allows several system performances measurements. The "openness" of the eye relates to the BER that can be achieved.

The vertical eye opening indicates the noise level in the system: the more it is opened the less noise level. The horizontal eye opening is related to the amount of jitter in the signal: the wider the opening, the less jitter.

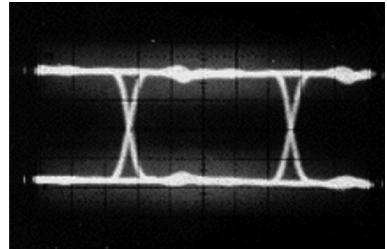
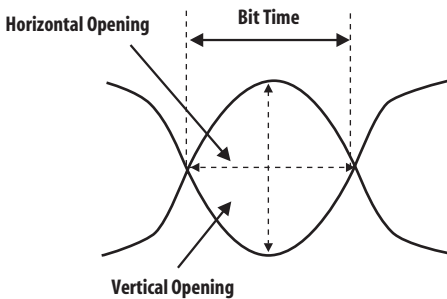

F

Fabry Perot (FP)

Generally refers to any device that uses mirrors in an internal cavity to produce multiple reflections.

Far-End Crosstalk

The ratio of the optical power that goes out from a given output port to an optical power that goes out from another output port, nominally isolated from the previous one, expressed in dB.

For WDMs the signal traveling in the two output paths have different wavelengths. The far-end crosstalk corresponds to the ratio of the optical power at a given wavelength which goes out from the corresponding output port to an optical power at the same wavelength which goes out from another output port, nominally isolated from the previous one at that wavelength.

For WDM components the term isolation is more commonly used than far-end crosstalk.

FC Connector

It is fixed by way of a threaded barrel housing. FC connectors are typical in test environments and for single-mode applications. FC connectors were designed for use in high-vibration environments.

Ferrule

A mechanical fixture, generally a rigid tube, used to confine and align polished or cleaved fiber ends in a connector. *See also* [Connector](#).

Fiber Bragg Grating (FBGs)

A FBG is a type of distributed Bragg reflector constructed in a short segment of optical fiber that reflects particular wavelengths of light and transmits all others. This FBG is achieved by adding a periodic variation to the refractive index of the fiber core, which generates a wavelength-specific mirror. A fiber Bragg grating can be used as an inline optical filter to block certain wavelengths, or as a wavelength-specific reflector.

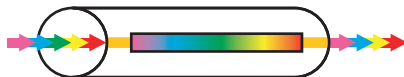

Fiber Fuse

A mechanism that may occur at high optical intensity ($>2 \text{ MW/cm}^2$), when the fiber is shocked or suddenly damaged. The reflection from the damage vaporizes the fiber immediately before its destruction. While this new defect remains reflective, part of the signal propagates back toward the transmitter.

In case of undersea cables, where high power levels might be used without the need for open fiber control, a "fiber fuse" protection device at the transmitter can break the circuit to prevent damage.

Fiber Grating

An optical fiber in which the refractive index of the core varies periodically along its length, scattering light in a way similar to a diffraction grating and transmitting or reflecting certain wavelengths selectively. See also [Fiber Bragg Grating](#).

Fiber

A glass or plastic thread that has the ability to guide light along its axis. The three parts of an optical fiber are the core, the cladding, and the coating or buffer.

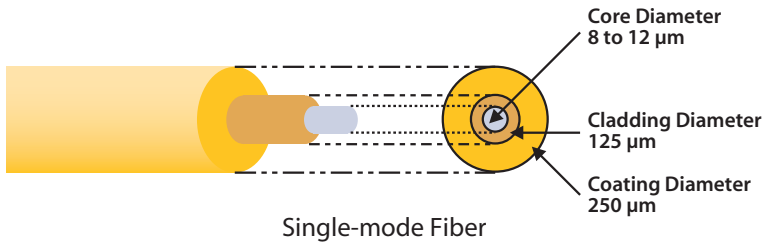

Fiber-to-the-Curb (FTTC)

A fiber-based telecommunications architecture which runs to a platform that serves several subscribers. Each of these customers is connected to this platform through traditional coaxial cable or twisted pair. The data rates offered to subscribers vary according to the distance the customer is from the platform.

FTTC differs from fiber to the node (FTTN) by the location of the cabinet. FTTC is placed near the curb and covers an area of 300 m in radius. FTTN is placed far from the customer and covers up to 1.5 km in radius.

Fiber-to-the-Node (FTTN)

A fiber-based telecommunications architecture which runs to a cabinet that serves a neighborhood. Subscribers are connected to this cabinet through traditional coaxial cable or twisted pair. The data rates offered to subscribers vary according to the distance the customer is from the platform.

FTTN differs from FTTC by the location of the cabinet. FTTN is placed far from the customer and covers up to 1.5 km in radius, whereas FTTC is placed near the curb and covers 300 m in radius.

Fiber-to-the-Home (FTTH)

Telecommunications architecture in which a communication path is provided over optical fiber cables extending from the telecommunications operator's switching equipment to (at least) the boundary of the home living space or business office space.

This communications path is provided for the purpose of carrying telecommunications traffic to one or more subscribers and for one or more services (for example Internet access, telephony and/or video-television). *See also* [Fiber-to-the-Premises \(FTTP\)](#).

Fiber-to-the-Premises (FTTP)

A fiber-based telecommunications architecture which runs directly onto the customers' premises (home or office).

This differs with other fiber-optic communication delivery strategies such as FTTN or FTTC, both depending upon more traditional methods such as copper wires or coaxial cable for last mile delivery.

FTTP can be further categorized according to where the optical fiber ends:

- The end user's home or office space, when the optical signal
-

reaches the end-user's living or office space as in the FTTH architecture.

- Optical Network Terminals, which convert the optical signal from the ODN⁽¹⁾ to electrical signal, to the end user.

(1) ODN: Optical Distribution Network. A device that distributes the optical signal from the central office.

Fiber-to-the-x (FTTx)

Systems that are capable of supporting a variety of residential voice, data, and video services. FTTx includes various architectures such as FTTC, FTTH, and FTTP.

Fiber Under Test (FUT)

Refers to the fiber being measured by some type of test equipment.

Filter

A device that allows transmitting a particular range of wavelengths, while blocking others.

Four Wave Mixing (FWM)

A common interference phenomenon in DWDM systems, where multiple wavelengths mix together to form new unwanted wavelengths.

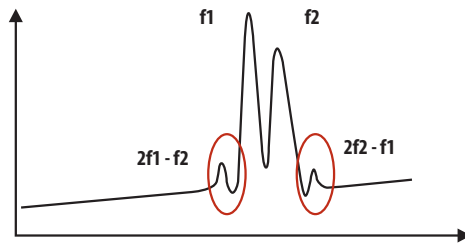

FWM Effect in a Two-Channel WDM System
on a Low Dispersion Fiber

FWM depends on many factors as dispersion, effective area, and channel spacing:

$$\text{FWM} \sim \frac{\text{POWER}^4}{\text{Dispersion}^2 \times \text{Effective Area}^2 \times \text{Channel Spacing}^4}$$

Fresnel Reflection Loss

Reflection loss at fiber ends due to the difference between glass and air refractive index. [See also Back Reflection.](#)

Full-Duplex Transmission

Simultaneous transmissions in both directions. [See Duplex Transmission.](#)

Full Width Half Maximum (FWHM)

The wavelength width corresponding to wavelengths emitting more than the half amplitude points of the power spectrum.

% of Spectral Emission

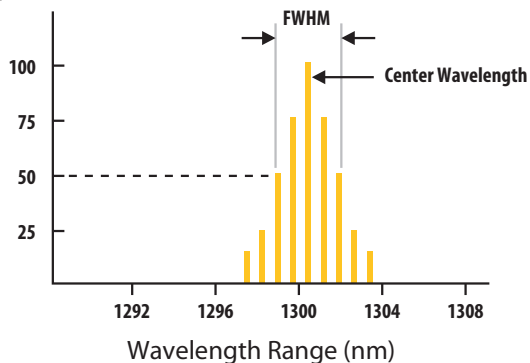

Fused Coupler

A device that is used to split optical signals between two fibers, or to combine optical signals from two fibers into one fiber. Fused couplers are constructed by fusing and tapering two fibers together.

The devices are bidirectional and offer low backreflection. The technique is best suited to single-mode and multimode couplers.

Fusion Splice

A permanent joint of two fibers made by heating and fusing them together.

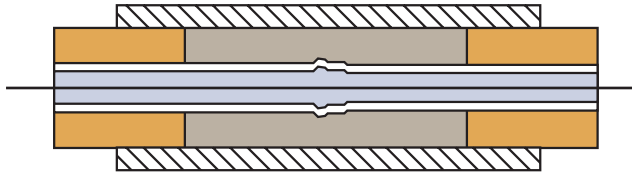

Fusion Splicer

An instrument used to make fusion splices.

G

Gain

The ratio of output current/voltage/power to input current/voltage/power. In case of a loss between input and output, the gain has a negative value, usually expressed in dB.

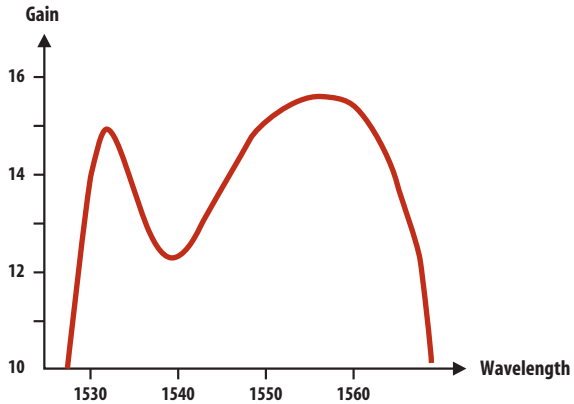

Typical Gain Curve of an EDFA

Gap Loss

Power loss resulting from the end separation of two aligned fibers.

Gain Slope

The slope of the gain spectrum over a determined range of wavelengths, which corresponds to the slope of least mean square regression line of total signal spectrum peaks. Gain slope is expressed in dB/nm.

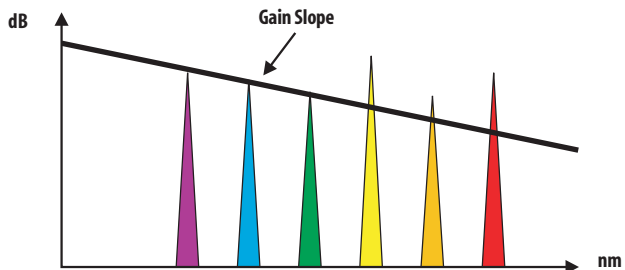

Gain Tilt

The difference in dB between the higher and the lower peak power of a WDM signal.

As seen on the EDFA typical gain curve, amplification level is wavelength-dependent: longer wavelengths are more amplified than shorter ones around 1550 nm, which causes gain tilt. When multiple EDFAs are present, this effect increases; so that at the end of the optical link, shorter wavelength power level will be very low and longer wavelength power level will be very high. To solve this problem, manufacturers try to flatten the gain spectrum.

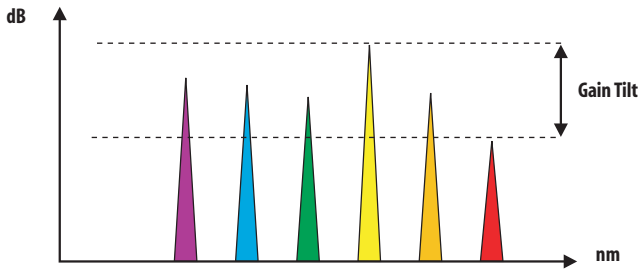

Graded-Index Fiber

Fibers obtained by giving the core a non-uniform refractive index, which decreases gradually from the central axis to the cladding. This index variation of the core forces the rays to progress within the fiber in a sinusoidal manner.

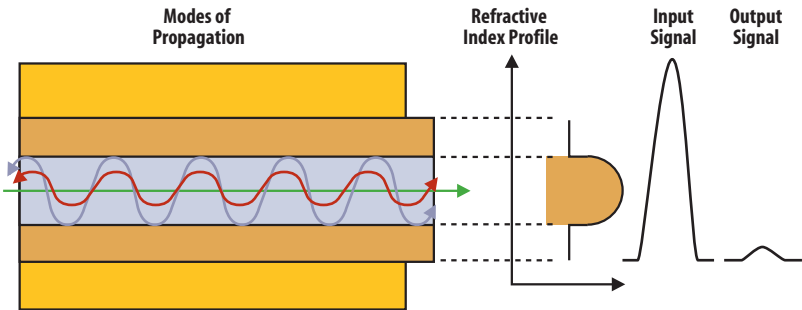

Group Index

The velocity of light in a vacuum (c), divided by the group velocity of the mode. Also called group refractive index.

Group Velocity

The velocity with which the envelope of the wave propagates through space.

H

Half-Duplex Transmission

Transmission in both directions, one direction at a time.

See [Duplex Transmission](#).

Hard-Clad Silica Fiber (HCS Fiber)

A type of optical fiber composed of a silica core surrounded by a hard polymer or similar material, which is much stronger than the customary cladding material.

HFC Network

A broadband network that combines optical fiber and coaxial cable, used by CATV companies that install fiber from the cable head-end to serve nodes located close to subscribers, and use coaxial cable from these nodes to individual businesses and homes.

Hybrid Fiber Coax (HFC)

A transmission system or cable construction that combines both fiber optic transmission and copper coax transmission.



I**Index-Matching Fluid**

A fluid used to enhance the transmission of light across a joint. Placed between two fiber ends being joined, this fluid reduces loss and back reflection due to its refractive index which remains closed to the refractive index of fiber cores.

Index of Refraction

The index of refraction is the ratio of the velocity of light in a vacuum to the velocity of light in a transparent material. The index of refraction can be used to calculate the bend angle of a beam of light as it passes from one transparent medium to another. Thus, the index of refraction is used as a quality control check of transparent plastics.

Infrared (IR)

The region of the electromagnetic spectrum bounded by the long-wavelength extreme of the visible spectrum (about 750 nm) and the shortest microwaves.

Infrared Emitting Diodes (IRED)

LEDs that emit infrared energy (830 nm or longer).

Injection Laser Diode (ILD)

A semiconductor composed of one p-n junction that emits coherent stimulated radiation under specified conditions.

In-Line Amplifier

An optical device (such as an EDFA) that reinforces the signal in a optical link. This allows pursuing the transmission over distance.

Insertion Loss

Optical power loss that results from a splice or from inserting a device (such as a connector or a coupler) into a previously continuous transmission path.

Insertion Loss = Power entering the device (in dB) – Power exiting the device (in dB)



Interchannel Isolation

The ability to prevent undesired coupling from one channel to another (crosstalk).

Interferometric Intensity Noise (IIN)

Noise generated within optical fiber. This disturbance is caused by the distributed back reflection that is generated by Rayleigh scattering. OTDRs measure this scattering power to deduce the fiber attenuation over distance.

Intermodulation (Mixing)

A fiber nonlinearity mechanism that occurs because the refractive index of glass is power-dependant. Signals hit each other and generate interferences at different frequencies. Similar to Four Wave Mixing.

Intrinsic Loss

Loss due to differences in the fibers being spliced.

Isolator

A device that allows light to pass along a fiber in only one direction. Isolators are essential in optical networks, especially with lasers that are sensitive to optical return loss.

J**Jacket**

The outer protective covering of a cable. Also called cable sheath.

L

Large Core Fiber

Optical fiber with a large core (usually greater than 200 μm), often a step-index fiber.

Large Effective Area Fiber (LEAF)

An optical fiber designed to have a large area carrying the light in the core. Corning has developed such fibers.

Laser

Acronym meaning Light Amplification by Stimulated Emission of Radiation. A light source that produces coherent, near monochromatic light through stimulated emission.

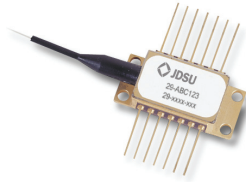

Example of Laser Component

Laser Diode (LD)

A semiconductor that emits high powered coherent light when stimulated by an electrical current. Used in transmitters for single-mode fiber links.

Lateral Displacement Loss

The attenuation that results from lateral misalignment between two fibers or between a fiber and an active device.

Launch Fiber

An optical fiber used to couple and suitably redistribute light from an optical source into an optical fiber. Often the launching fiber is used to create an equilibrium mode distribution in a multimode fiber.

Long Wavelength Band (L-Band)

A transmission band for wavelength from 1565 to 1625 nm. Part of third window. [See also Transmission Band.](#)

Light Emitting Diode (LED)

A semiconductor device used to transmit optical power into a fiber in response to an electrical signal.

Lightguide

Synonymous with optical fiber.

Light Source

In fiber optics, a transmitting LED or laser diode, or an instrument used as a continuous and stable source (CW) for attenuation measurements.

Link (Optical)

Part of an optical fiber communications system that links two points. It basically consists of a data transmitter, a transmission fiber (possibly with built-in fiber amplifiers), and a receiver.

Long Wavelength

A commonly used term for light in the 1300 and 1550 nm ranges.

Loose-Tube Buffering

A type of fiber optic cable construction where fibers are contained within an outer protective tube yet can move to some extent.

Loss Budget

[See Optical Link Loss Budget.](#)

M

Macroband

A macroscopic bend causing light leakage out of the fiber, and consequently signal attenuation.

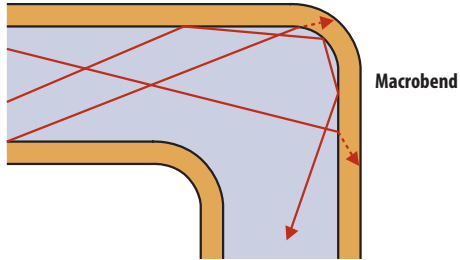

Material Dispersion

Dispersion due to the wavelength dependency of the velocity of propagation on the material from which the fiber is made.

Mechanical Splice

A technique used to join two fibers permanently using fixtures or materials (unlike thermal fusion).

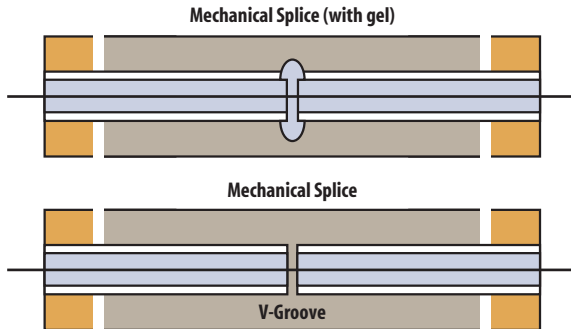

Microbend

Sharp and microscopic curvature of a fiber caused by external factors such as cabling. This creates spatial wavelength displacements of a few millimeters, and thereby disturbances.

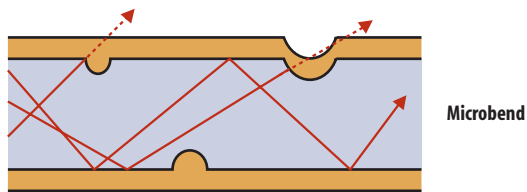

Minimum Bend Radius

The smallest radius an optical fiber or fiber cable can be bent before increased attenuation or damage occurs.

Modal Dispersion

Dispersion that occurs in multimode fibers, because light travels in multiple modes (reflective paths), and each path results in a different travel distance.

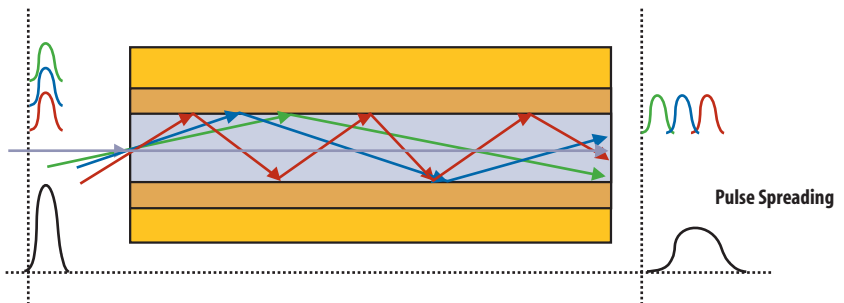

Modal Dispersion in a Multimode Step Index Fiber

Modal Noise

Signal disturbances occurring when the signal propagates through mode-selective devices. Usually related to laser light sources.

Mode Coupling

In a fiber, the exchange of power from one mode to another.

Mode Field Diameter (MFD)

A measure of the spot size or beam width of light propagating in a single-mode fiber. MFD is a function of source wavelength, fiber core radius, and fiber refractive index profile.

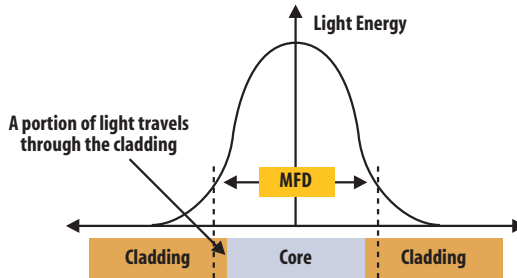

Mode Filter

A device that removes, selects, or attenuates one specific or several modes. Used to simulate equilibrium mode distribution.

Mode Scrambler

A device that mixes optical power to achieve equal power distribution in all modes.

Mode Stripper

A device used to remove cladding modes.

Multimode Dispersion

See [Modal Dispersion](#).

Multimode Fiber (MMF)

A waveguide through which several modes propagate. The core diameter is much larger than the wavelength of light (typically 50 or 62.5 μm). Commonly used with LED sources for lower speed, short distance links.

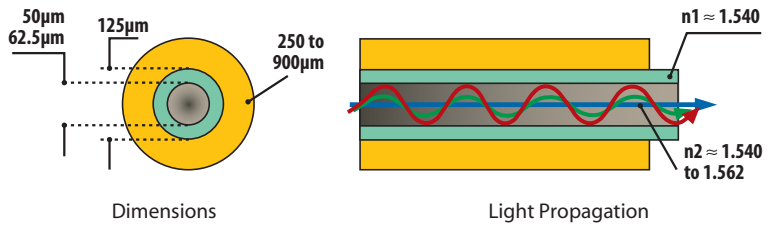

Multipaths Interference

See [Multiple Reflection Noise](#).

Multiple Reflection Noise (MRN)

A phenomenon whereby a signal travels through several paths, whereby components of the signal interfere with one another together.

Multiplexer (Mux)

A device that allows the transmission of two or more signals over a single communication channel.

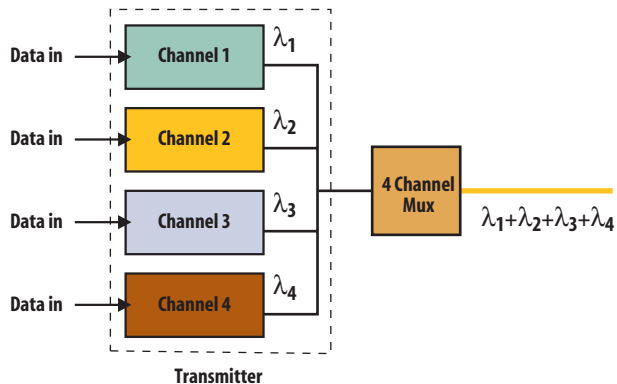

Multi-Quantum Well (MQW) Laser

A laser structure composed of a very thin layer of bulk semiconductor material sandwiched between the two barrier regions of a higher band gap material. Such a structure limits the motion of electrons and holes and forces energies for motion to be quantized and only occur at discrete energies.

N

Near-End Crosstalk (NEXT)

NEXT corresponds to the optical power that is reflected from input ports back to another input port. Also known as isolation directivity.

Noise (Optical)

An undesired disturbance that affects a signal and that may distort the carried data.

Non Dispersion-Shifted Fiber (NDSF)

A type of fiber designed to have a zero-dispersion wavelength near 1310 nm. This is the most popular type of single-mode fiber deployed.

Non Zero-Dispersion-Shifted Fiber (NZ-DSF)

A type of single-mode fiber designed to have the zero-dispersion wavelength near the 1550 nm window outside the window used for the transmission. This allows minimizing the four-wave mixing phenomenon and other nonlinear effects and maximizing bandwidth.

NZ-DSF fibers have been normalized by the ITU as G.655.

Numerical Aperture (NA)

A value that expresses light gathering capacity of a fiber related to the acceptance angle. The sine of 5% optical power angle (corresponding to -13 dB) is used to measure the Numerical Aperture.

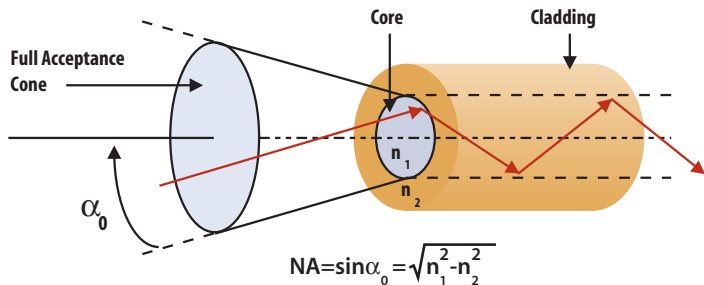

O**Open Optical Interface (OOI)**

An interface that permits an optical signal to pass without conversion from the optical signal to an electrical signal and, therefore, does not limit the signal to a specific protocol.

Optical Add/Drop Multiplexer (OADM)

See [Add/Drop Multiplexer \(ADM\)](#).

Optical Continuous Wave Reflectometer (OCWR)

An instrument that allows measuring component reflectance and link optical return loss (ORL) of an optical link by transmitting an unmodulated signal through the link and measuring the light scattered and reflected back to the input.

Optical Cross-Connect (OXC)

A network device used to switch high-speed optical signals in their entirety (without multiplexing them together).

OXCs work entirely at the optical layer and may be able to operate without having to convert to electrical and back again.

Optical Directional Coupler (ODC)

A component that combines and separates optical power.

Optical Link Loss Budget

The amount of power lost along the link. Often used in terms of the maximum amount of loss that can be tolerated by a given link.

Optical Loss Test Set (OLTS)

An instrument that includes both a meter and source, used to measure optical loss.

Optical Multiplex Section (OMS)

A DWDM system section that includes an optical add/drop multiplexer (OADM).

Optical Path Power Penalty

The extra loss budget required to account for losses caused by reflections, dispersion, mode partition noise, and laser chirp.

Optical Return Loss (ORL)

The ratio (expressed in dB) of the reflected power to the incident power from a fiber optic system or link.

$$\text{ORL} = 10 \log (P_i/P_r)$$

Optical Spectrum Analyzer (OSA)

An optical instrument for measuring properties of light over some portion of the electromagnetic spectrum. The measured variable is often the light intensity but could also be the polarization state.

Commonly used to diagnose DWDM systems.

Optical Time Domain Reflectometer (OTDR)

An instrument that uses backscattered light to characterize a fiber-optic link. Such an instrument allows estimating fiber link attenuation, attenuation coefficient, discrete reflections, splice/connector loss, and point defects, all as a function of fiber distance.

Original Band (O-Band)

A transmission band for wavelength from 1260 to 1360 nm.

See also [Transmission Band](#).

P

Passive Optical Network (PON)

A system that brings optical fiber cabling and signals all or most of the way to the end user. Depending on where the PON terminates, the system can be described as fiber-to-the-curb (FTTC), fiber-to-the-building (FTTB), or fiber-to-the-home (FTTH). A PON consists of an optical line termination (OLT) at the communication company's office and a number of optical network units (ONUs) near end users.

Patchcord

A cable assembly permanently assembled at both ends with connector components (principally for cross-connection within a patching facility).

Peak Wavelength

In optical emitters, wavelength at which the maximum emission occurs. Also called peak emission wavelength.

Photodiode (PD)

A semiconductor device that converts light to electrical current. Photodiodes have different spectral characteristics depending on the type of semiconductor.

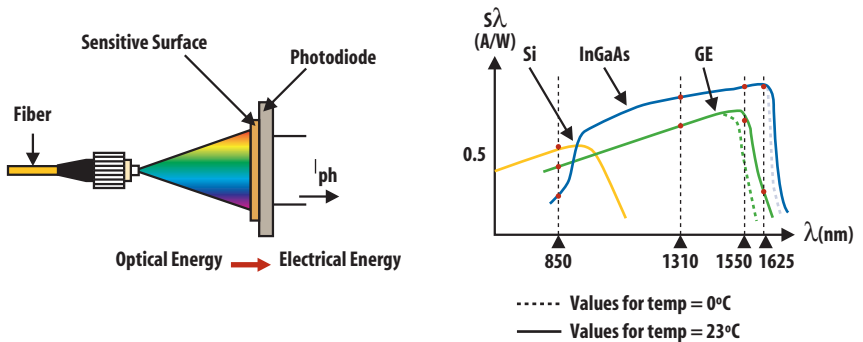

Physical Contact (PC)

Refers to an optical connector minimizing backreflection and insertion loss. The connection is made by the physical touching of fiber ends.

Physical Contact (PC) Connector

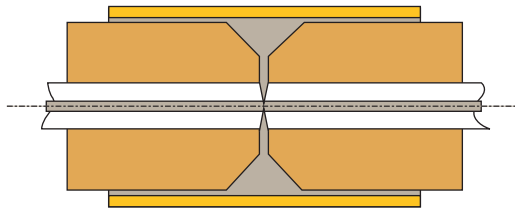

Insertion Loss: 0 to 0.5 dB
Optical Return Loss: >40 dB

Pigtail

A short optical fiber cable permanently placed between an optical device (such as a source or detector) and an optical connector. This allows easy connection to another optical component.

PIN Photodiode

See [Photodiode](#).

Plastic Clad Silica (PCS)

A step-index fiber composed of a glass core and a plastic or polymer cladding. Also called hard clad silica (HCS).

Plastic Fiber

An optical fiber composed of a plastic core and plastic cladding.

Polarization

Light consists of oscillating electrical fields that are said to be polarized when oscillating in a particular way. Horizontally polarized light corresponds to the electric field oscillating along the X axis, whereas vertically polarized light is related to the electric field oscillating along the Y axis.

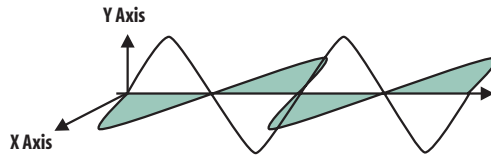

Polarization Maintaining Fiber (PFM)

Type of fiber that propagates only one polarization of light.

Polarization Mode Dispersion (PMD)

A basic property of single-mode fibers. PMD affects the magnitude of the transmission rate and results from the difference in propagation times of the energy of a given wavelength, which is split into two polarization axes that are at right angles to each other (see below). Main causes of PMD are noncircularities of the fiber design and external applied stress (macro-bending, micro-bending, twist and temperature variations).

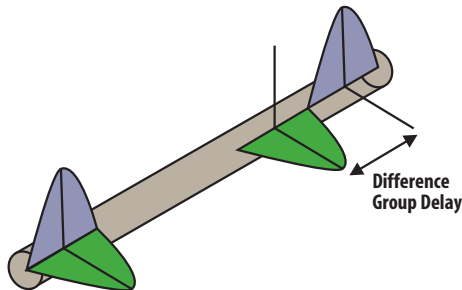

Power Meter (Optical)

An instrument that measures the optical power at the end of a cable.

Profile Dispersion

In a fiber, a dispersive mechanism due to the wavelength-dependency of refractive index profile. This dependency is related to the variation in refractive index contrast and in profile parameters.

Pulse Dispersion

See [Pulse Spreading](#).

Pulse Spreading

The separation (or spreading) of the signal input characteristics that appear along the length of the fiber and limit the useful transmission bandwidth of the fiber. Three basic mechanisms are the material dispersion, the waveguide dispersion, and the multimode effect.

Pump Laser (Optical)

A semiconductor laser that provides the light that excites atoms in a fiber amplifier, putting them in the right state with which to amplify light.

See also [EDFA](#).



Q**Quantum Efficiency**

In a photodiode, the percentage of photons that generates an electron-hole pair when hitting the photo-reactive surface.

(Processes by which mobile electrons and electron holes are created and eliminated correspond to the carrier generation and recombination.)



R

Radiation-Hardened Fiber

An fiber made with core and cladding materials specially designed to recover a specified percentage of their intrinsic attenuation coefficient, within a defined time period, after exposure to a radiation pulse.

Raman Amplifier

A device that boosts the signal in an optical fiber by transferring energy from a powerful pump beam to a weaker signal beam. It relies on the interaction between light and atoms in the fiber. Unlike erbium-doped fiber amplifiers (EDFAs), which boost wavelengths in the 1530-1610 nm range, a Raman amplifier can increase the signal strength of any wavelength.

Rayleigh Scattering

The scattering of light that occurs when light travels in the fiber as a result of small inhomogeneities of the core.

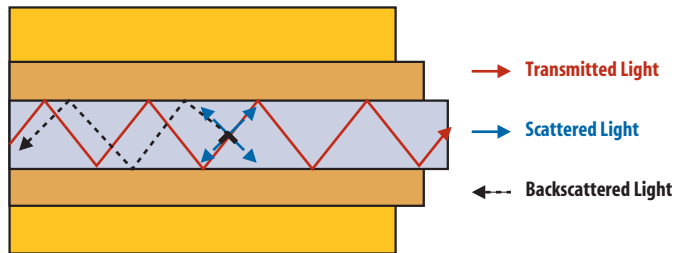

Backscattering Effect

Receiver

A terminal device that detects a communication signal and converts it into data, sound, or video. A receiver is composed of a detector and signal processing electronics.

Reflectance

The ratio of reflected power (P_r) to incident power (P_i) of an event (such as a connector).

$$R = 10 \log (P_r/P_i).$$

Refraction

The deviation of light wave it passes between two materials having different refraction index.

Refractive Index

The index of refraction is the ratio of the velocity of light in a vacuum to the velocity of light in a transparent material. The index of refraction can be used to calculate the bend angle of a beam of light as it passes from one transparent medium to another. Thus, the index of refraction is used as a quality control check of transparent plastics.

Refractive Index Gradient

The variation in refractive index as a function of distance from the longitudinal axis of a graded index optical fiber.

Relative Intensity Noise

Noise of the optical intensity (or actually power), normalized to its average value. Often used to quantify the noise characteristics of a laser.

Repeater

A device used to regenerate an optical signal. Used to extend operating range.

Responsivity

Measures the input–output gain of a detector system. In the specific case of a photodetector, it measures the electrical output per optical input. Many common photodetectors respond linearly as a function of the incident power.

Responsivity of a photodetector is usually expressed in amperes per watt, or volts per watt, of incident radiant power. It is a function of the wavelength of the incident radiation and of the sensor properties, such as the bandgap of the material of which the photodetector is made.

Return Loss

See Optical Return Loss.

Ribbon Cables

A group of attached parallel wires or optical cables. Also called flat cable. See also Cable.

S

Scattering

A phenomenon causing the direction change of light rays after striking discontinuities in the medium, or interacting with the material at the atomic or molecular level.

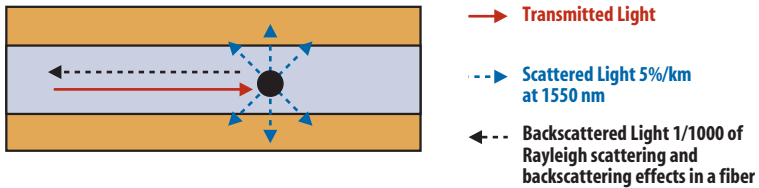

Scattering and Backscattering Effects in a Fiber

Self-Phase Modulation (SPM)

A nonlinear effect caused by a refractive index variation (Kerr effect). This variation induces a phase shift in the light pulse, leading to a change of the pulse frequency.

Semiconductor Optical Amplifier (SOA)

A laser diode without end mirrors that is coupled to fibers on both ends. Light propagating in either fiber is amplified by a single pass through the laser diode. An alternative to EDFAs.

Sheath

Synonymous for jacket.

Short Wavelength Band (S-Band)

The wavelength region between 1460 and 1530 nm used in some CWDM and DWDM applications. *See also* [Transmission bands](#).

Silica Glass

Glass used in conventional optical fibers. Mostly made of silicon dioxide (SiO_2).

Signal-to-Noise Ratio (SNR)

A measure of the relative optical signal power to the optical noise power over a given spectral bandwidth. Also called Optical Signal-to-Noise Ratio (OSNR).

Simplex

A fiber-optic transmission system in which data can go in only a one direction.

Simplex Cable

A single-fiber cable suitable for simplex transmission.

Simplex Transmission

Transmission in only one direction. Also referred to as half-duplex transmission.

Single-Line Laser

See [Single-Longitudinal Mode Laser \(SLM\)](#).

Single-Longitudinal Mode Laser (SLM)

An injection laser diode that emits a single dominant longitudinal mode.

Single-Mode Fiber (SMF)

A small-core optical wave guide through which only one mode propagates. The typical core diameter is 8-12 microns.

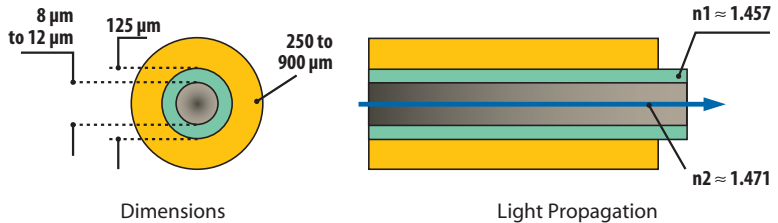
**Single-Mode Laser Diode (SMLD)**

See [Single-Longitudinal Mode Laser \(SLM\)](#).

Slope Efficiency (SE)

A property of an optically pumped laser. Its value corresponds to the slope of the curve obtained by plotting the laser output versus the pump power. Also referred to as differential efficiency.

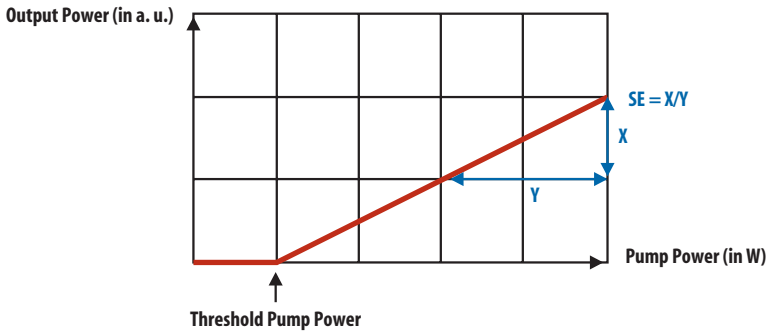

Soliton Pulse

An optical pulse with a shape, spectral content, and power level designed to take advantage of nonlinear effects in an optical fiber, mainly for negating dispersion over long distances.

Source

In fiber optics, a transmitting LED or laser diode that injects an optical signal into fibers.

Span (Optical)

An optical fiber/cable terminated at both ends. Such cables sometimes include additional devices to add, extract, or attenuate optical signals.

Spectral Efficiency

Data rate (in bits per second) that can be achieved in a one Hertz bandwidth range.

Spectral Width

The range of wavelengths emitted by a source. Typical spectral widths are 50 to 160 nm for an LED and less than 5 nm for a laser diode.

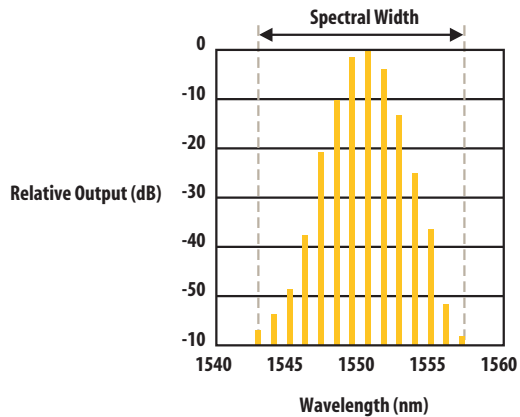

Splice

A permanent connection of two optical fibers. Main splice techniques consist of thermal fusion or mechanical fixtures. [See also Fusion Splice and Mechanical Splice.](#)

Splice Loss

Any loss of optical power at a splice. Such losses are caused by various mechanisms, either intrinsic to the fibers, or intrinsic to the method or device being used to join them.

Splitter

[See Coupler.](#)

Splitting Ratio

In a coupler, the ratio of power emerging from two ports.

Stabilized Light Source

A LED or laser diode that emits light with a controlled and constant spectral width, center wavelength, and peak power with respect to time and temperature.

Step-Index Fiber

A fiber having a uniform refractive index in the core. Such a fiber guides light rays through total reflection on the boundary between the core and cladding.

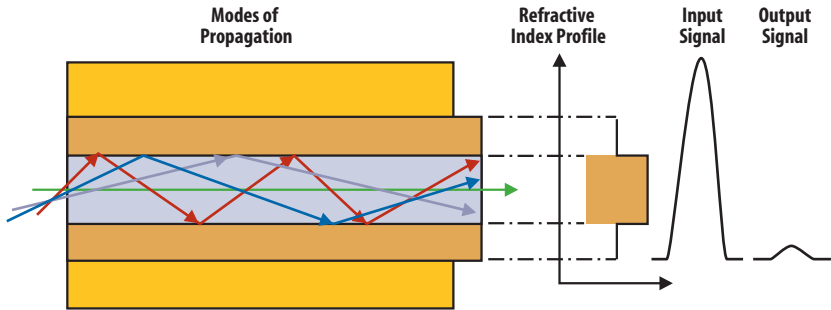

Stimulated Brillouin Scattering (SBS)

A phenomenon that occurs when intense beams, such as laser light, travel in an optical fiber, causing variations in the electric field of the beam itself. Acoustic vibrations are produced in the medium. This may involve wave propagating in the opposite direction of the incoming beams.

Stimulated Raman Scattering (SRS)

A nonlinearity similar to SBS but with a much higher threshold. This phenomenon may rob power from shorter wavelength signals and add gain to longer wavelength signals.

Surface-Emitting Diode (SLED)

A simple and inexpensive LED that emits light from its flat surface rather than its edge.

T

Tap Loss

In a coupler, the ratio of power at the tap port to the power at the input port.



Tap Port

In a coupler, the output port of lesser power where the splitting ratio between the output ports are not equal.

Temperature Induced Cable Loss (TICL)

Optical loss resulting from extreme temperatures out of environmental specifications of a cable.

Throughput Loss

In a fiber optic coupler, the ratio of power at the throughput port to the power at the input port.

Throughput Port

In a coupler, the output port of greater power where the splitting ratio between output ports is not equal.

Tight-Buffer

Protective material surrounding the cladding of a fiber that avoids the fiber moving within it.

Total Internal Reflection

A phenomenon that occurs when the incidence angle of light striking an interface is greater than the critical angle. If the refractive index is lower on the other side of the boundary no light can pass through, and then all of the light is reflected.

This can only occur where light travels from a medium with a higher refractive index to one with a lower refractive index. For example, when passing from glass to air.

Transmission Bands

Optical transmissions are not transmitted continuously over the whole electromagnetic spectrum.

The spectrum for transmission in single-mode optical fibers has been broken into the following wavelength ranges, or bands:

- O-band (Original) from 1260 to 1360 nm
- E-band (Extended) from 1360 to 1460 nm
- S-band (Short wavelength) from 1460 to 1530 nm
- C-band (Conventional) from 1530 to 1565 nm
- L-band (Long wavelength) from 1565 to 1625 nm
- U-band (Ultra-long wavelength) from 1625 to 1675 nm

The wavelengths transmitted in multimode fibers are typically around 850 and 1310 nm, known originally as first window and second window.

O-band covers the second transmission window, whereas S, C, and L-bands cover the third transmission window. Presently, the vast majority of DWDM transmissions are done in the C-band.

Transmitter

A device that functions as an electrical-to-optical converter for transmission through a fiber. The transmitter can be an LED, laser diode, or vertical cavity surface.



U

Ultra-Long Wavelength (U-Band)

A transmission band for wavelength from 1565 to 1625 nm.

See also [Transmission Band](#).

Ultraviolet (UV)

Region of the electromagnetic spectrum in which the longest wavelength is just below the visible spectrum, extending from approximately 4 nm to 400 nm.

V**Vertical Cavity Surface-Emitting Laser (VCSEL)**

A type of laser that emits light perpendicularly out of the chip (unlike out of the edge). VCSELs are composed of two high-reflecting mirrors that are incorporated into the laser structure to form the optical cavity. They have very small dimensions in comparison with conventional lasers and are very efficient.

Vertical Extended Cavity Surface-Emitting Laser (VECSEL)

A laser that has a surface-emitting semiconductor gain element coupled to an external mirror designed to complete the laser resonator. VECSELs can be electrically or optically pumped. The extended cavity can emit high power from a relatively large emitting area.

Visual Fault Locator (VFL)

The visual fault locator is a visual light source used to locate breaks or points of excess loss in fiber cable.

W

Waveguide

Synonymous with optical fiber.

Wavelength

The distance between two consecutive cycles of a wave. The wavelength in meters is computed by dividing the propagation speed by the frequency.

Wavelength is related to a color of light and is usually expressed in nanometers (nm).

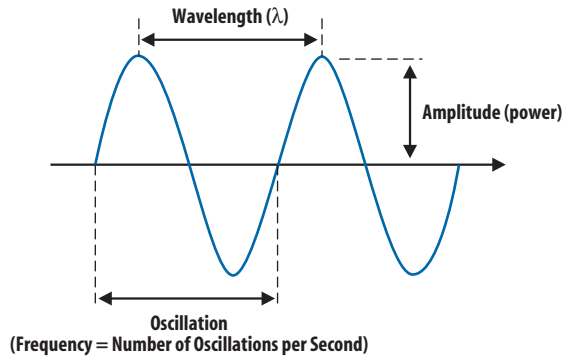

Wavelength Division Multiplexing (WDM)

A method of combining multiple signals on laser beams at various wavelengths for transmission along one fiber optic cable. See also Dense Wavelength Division Multiplexing (DWDM) and Coarse Wavelength Division Multiplexing (CWDM).

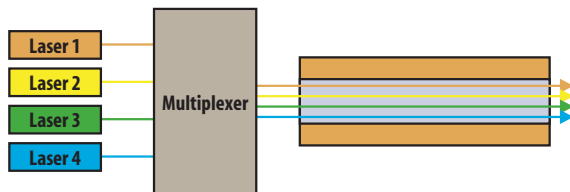

Wavelength Isolation

Synonymous with far-end crosstalk.

Wavelength Selective Coupler

A device that couples the pump laser wavelength to the fiber while filtering out all other undesired wavelengths. Used in erbium-doped fiber amplifiers (EDFAs).

Z**Zero-Dispersion Slope**

In single-mode fiber, the rate at which dispersion changes with respect to wavelength at the zero-dispersion wavelength.

Zero-Dispersion Wavelength

In a single-mode fiber, the wavelength at which material waveguide dispersion cancels one another. This value corresponds with the maximum bandwidth.



Acronyms and Abbreviations

Section 2



ADM	Add/Drop Multiplexer
ADZ	Attenuation Dead Zone
APC	Angled Physical Contact
APD	Avalanche Photodiode
ASE	Amplified Spontaneous Emission
AWG	Arrayed Waveguide Grating
BER	Bit Error Rate
BR	Back Reflection
BW	Bandwidth
C-Band	Conventional Band
CD	Chromatic Dispersion
CNR or C/N	Carrier-to-Noise Ratio
CW	Continuous Wave
CWDM	Coarse Wavelength Division Multiplexing
dB	Decibel
DCF	Dispersion-Compensating Fiber
DCM	Dispersion-Compensating Module
DCU	Dispersion-Compensating Unit
Demux	Demultiplexer
Dense WDM	Dense Wavelength Division Multiplexing
DFB	Distributed Feedback Laser
DST	Dispersion-Supported Transmission
DUT	Device Under Test
DWDM	Dense Wavelength Division Multiplexing
E-Band	Extended Band
EDFA	Erbium Doped Fiber Amplifier

EDZ	Event Dead Zone
ELED	Edge-Emmitting Light-Emitting Diode
E/O	Electrical-to-Optical Converter
EMD	Equilibrium Mode Distribution
FBGs	Fiber Bragg Gratings
FC	Fixed Connection
FP	Fabry-Perot
FTTC	Fiber-to-the-Curb
FTTN	Fiber-to-the-Node
FTTH	Fiber-to-the-Home
FTTP	Fiber-to-the-Premises
FTTx	Fiber-to-the-x
FUT	Fiber Under Test
FWHM	Full Width Half Maximum
FWM	Four Wave Mixing
GRIN	Gradient Index
HCS	FiberHard-Clad Silica Fiber
HFC	Hybrid Fiber Coax
IDP	Integrated Detector/Preamplifier
IIN	Interferometric Intensity Noise
ILD	Injection Laser Diode
InGaAs	Indium Gallium Arsenide
InGaAsP	Indium Gallium Arsenide Phosphide
InP	Indium Phosphide
IR	Infrared
IREDD	Infrared Emitting Diodes

L-Band	Long Wavelength Band
LD	Laser Diode
LEAF	Large Effective Area Fiber
LED	Light Emitting Diode
MFD	Mode Field Diameter
MM	Multimode
MMF	Multimode Fiber
MQW	Multi-Quantum Well
MRN	Multiple Reflection Noise
MUX	Multiplexer
NA	Numerical Aperture
NDSF	Non-Dispersion-Shifted Fiber
NEXT	Near-End Crosstalk
NZ-DSF	Non-Zero-Dispersion Shifted Fiber
OADM	Optical Add/Drop Multiplexer (ADM)
O-Band	Original Band
OCH	Optical Channel
OCWR	Optical Continuous Wave Reflectometer
ODC	Optical Directional Coupler
ODN	Optical Distribution Network
O/E	Optical toElectrical
OLT	Optical Line Termination
OLTS	Optical Loss Test Set
OMS	Optical Multiplex Section
ONI	Optical Network Interface
ONT	Optical Network Termination

ONU	Optical Network Unit
OOI	Open Optical Interface
ORL	Optical Return Loss
OSA	Optical Spectrum Analyzer
OSNR	Optical Signal-to-Noise Ratio
OTDR	Optical Time Domain Reflectometer
OXC	Optical Crossconnect
PC	Physical Contact or Polished Contact
PCS Fiber	Plastic Clad Silica fiber
PD	Photodiode
PFM	Polarization Maintaining Fiber
PMD	Polarization Mode Dispersion
RIN	Relative Intensity Noise
S-Band	Short Wavelength Band
SBS	Stimulated Brillouin Scattering
SC connector	Subscription Channel connector
SE	Slope Efficiency
SLED	Surface Light Emitting diode
SLM	Single-Longitudinal Mode Laser
SM	Single Mode
SMLD	Single-Mode Laser Diode
SMF	Single-Mode Fiber
SNR or S/N	Signal-to-Noise Ratio
SOA	Semiconductor Optical Amplifier
SPM	Self-Phase Modulation
SRS	Stimulated Raman Scattering

ST Connector	Straight Tip Connector
TICL	Temperature Induced Cable Loss
U-Band	Ultra-Long Wavelength Band
UV	Ultraviolet
VCSEL	Vertical Cavity Surface-Emitting Laser
VECSEL	Vertical Extended Cavity Surface-Emitting Laser
VFL	Visual Fault Locator
WDM	Wavelength Division Multiplexing
XC	Crossconnect
XPM	Cross-Phase Modulation
XT	Crosstalk

Notes:



Chromatic Dispersion

Test and Measurement

0.051 dB

10320.34 m

0.197 dB/km

0.1 dB Noise Level

Noise Level (3 dB BW)

Noise Level (10 dB BW)

-4

Product specifications and descriptions in this document subject to change without notice. © 2008 JDS Uniphase Corporation

FO-GLOSSARY

Rev. 000

30149264.000.0408.GLOSSARY.BK.FOP.TM.AE



Test & Measurement Regional Sales

North America

Toll Free: 1 866 228 3762

Tel: +1 301 353 1560 x 2850

Fax: +1 301 353 9216

Latin America

Tel: +55 11 5503 3800

Fax: +55 11 5505 1598

Asia Pacific

Tel: +852 2892 0990

Fax: +852 2892 0770

EMEA

Tel.: +49 7121 86 2222

Fax: +49 7121 86 1222

www.jdsu.com