

## XC7Z035, XC7Z045, and XQ7Z045 Banks

Figure 1-5 shows the I/O banks for the XC7Z035, XC7Z045, and XQ7Z045.

### **FB676/FBG676/FBV676, FF676/FFG676/FFV676, and RF676/RFG676 Packages**

- HR I/O banks 9, 10, and 11 are not bonded out in this package.
- All HP I/O banks are fully bonded out.
- GTX Quads 109 and 110 are not bonded out in this package.
- All PS banks are fully bonded out.

### **FF900/FFG900/FFV900 and RF900 Packages**

- HR I/O bank 9 is partially bonded out in this package.
- All HP I/O banks are fully bonded out.
- All GTX Quads are fully bonded out.
- All PS banks are fully bonded out.

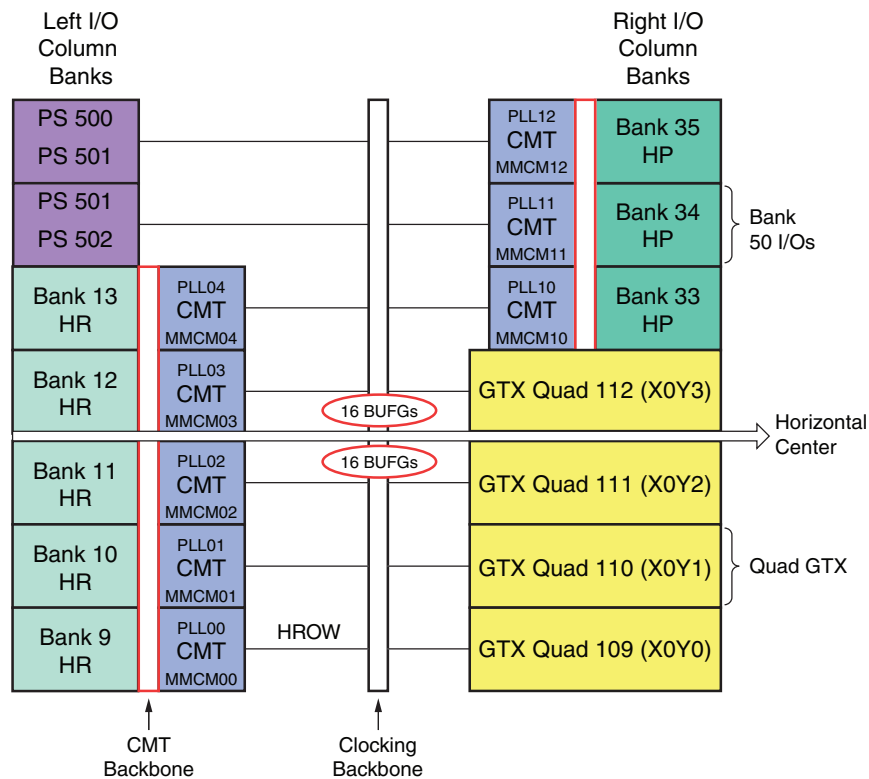

UG865\_c1\_04\_050414

Figure 1-5: XC7Z035, XC7Z045, and XQ7Z045 Banks