



Schroff[®]

SPECIFIER'S GUIDE

SUBRACKS • CASES • PANELS • PLUG-IN UNITS • RETAINERS

Pentair Technical Product's Schroff® brand has been a world-leader in the electronics packaging industry for over four decades. Schroff supplies subracks and accessories, instrument cases, 19-in. cabinets, backplanes, integrated systems and enclosure hardware, complete packaging systems for MicroTCA, Advanced TCA, CompactPCI, PXI, VME, VME64x, VPX, VXS and customer-specific enclosure systems.

Table of Contents

Product Description

Cases - form and functions for a wide range of industries 1
 Systems - from a single source..... 1
 Subracks - a modular toolbox 1
 Front panels - products plus services for any requirements..... 1
 Retainers - design flexibility for any requirement 1

Front Panels

Overview 2
 Plug-in Units 2
 Front Panels 2
 AdvancedMC-Modules 2
 Front Panel Selection Guide 3
 Front Panel Express - when customized panels are required - FAST! .. 4
 Front Panels, unshielded 5
 Front Panels, U profile, shieldable 6
 PMC Mezzanine Front Panels with handle, shielded..... 7
 Cantilever Extraction Handles 7

Plug-in Units

Plug-In Unit Kits for AdvancedTCA-IEA with die-cast end piece handles 8
 Plug-In Unit Kits for CompacPCI and VME64x applications 8
 Plug-In Unit Kits with cantilever extraction handle type 2 for VME applications..... 9
 AdvancedMC-Modules with Pull-Handle Mechanism for PIGMG AMC.0 R2.0 applications..... 9

Subracks

Overview 10
 europacPRO 10
 inpac 10
 multipacPRO..... 10
 Subrack Selection Guide 11
 europacPRO—Kits, unshielded, for backplane mounting 12
 europacPRO—Kits, shielded, for backplane mounting 13
 europacPRO—Kits, shielded, for CompactPCI with backplane mounting for rear I/O..... 14
 Guide Rails for plug-in units and modules 15
 Horizontal Boards mounting in 3 or 4 U subracks 15
 Divider Plates 16
 Mounting Plates 16
 inpac—19-in. chassis 17
 multipacPRO—19-in. complete steel chassis, plain top cover and base plate 18

Schroff®, Calmark™ and Birtcher™ printed circuit board retainers, conduction-cooled frame assemblies, and extractors are designed for use in rugged environments with high shock and vibration, and conduction cooling requirements. A large variety of retainers are available to meet your needs for highly rugged to less rugged applications.

Cases

Overview 19
 comptec..... 19
 compacPRO..... 19
 ratiopacPRO 19
 Cases Selection Guide..... 20
 comptec—19-in. cases 3, 4, 6, 9 U 21
 compacPRO—Cases 2, 3 and 4 U 22
 compacPRO—Accessories 23
 ratiopacPRO—Cases 24
 ratiopacPRO-air—Cases..... 25
 ratiopacPRO, ratiopacPRO-air—Accessories 26

Retainers

Calmark® and Birtcher® 28

Calmark Products

Card-Lok Features..... 29
 Series 260—Card-Loks 29
 Series LE260—Card-Loks 29
 Series 223 and 224—Torque Limiting Card-Loks 29
 Series 120 Nylon 29
 Extractors / Inserts 30
 Coding Keys / Inserts..... 30
 Conduction Cooled Assemblies 30

Birtcher Products

Wedge-Lok Features 31
 Series 48-5—Wedge-Loks..... 31
 Series 48SL—Wedge-Loks..... 31
 Series 120 Nylon 31
 Extractors / Inserts 31
 Series 340 Wedge-Tainer 31
 Wedge-Lok / Card-Lok Selection Guide..... 32
 Birtcher Standard Products..... 32
 About Pentair Products and Locations..... 33

Product Description

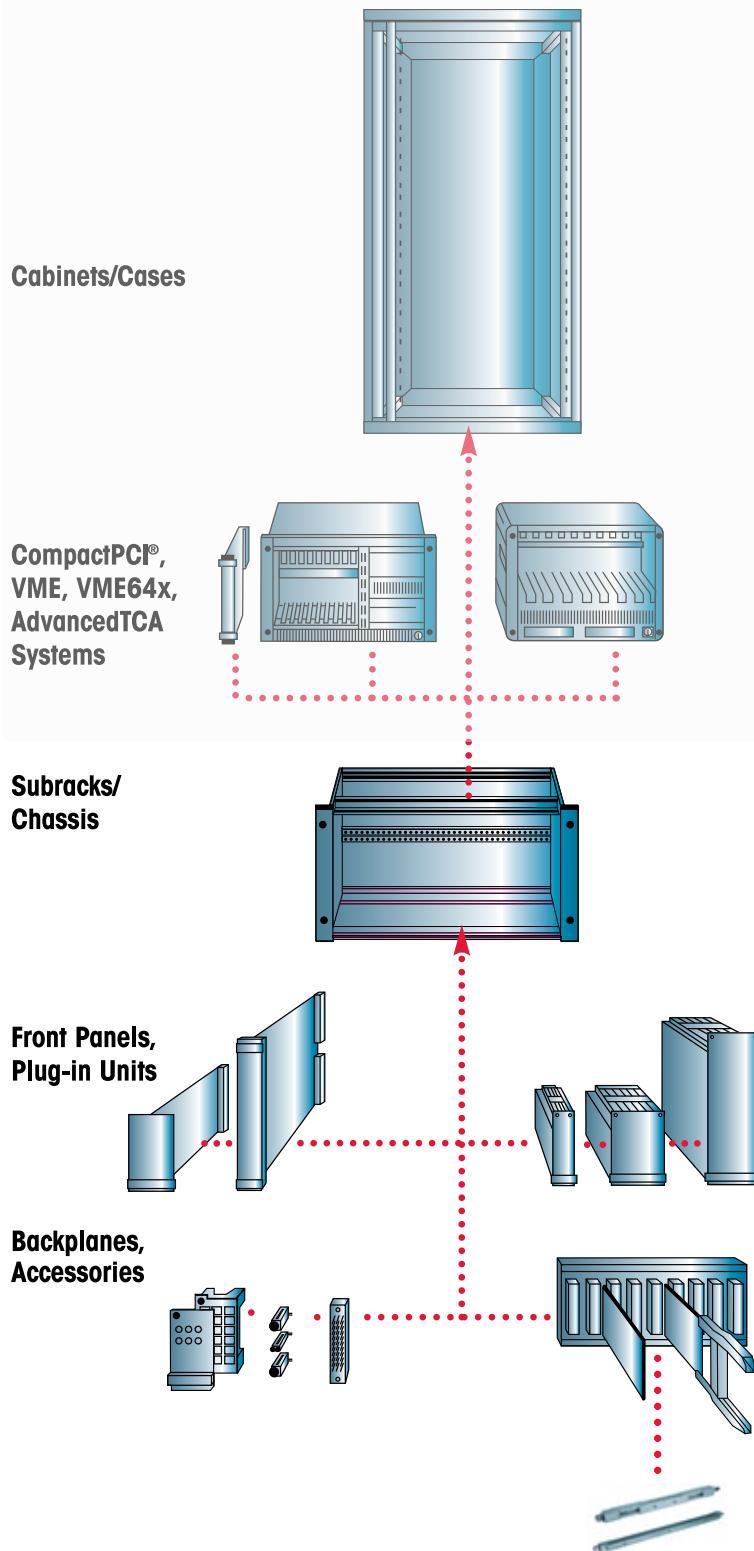

Cases—form and functions for a wide range of industries

Schroff instrument and system cases provide fully functional, stylish enclosures offering high-quality protections for electronic equipment. Our cases can be configured to meet most applications using our standard catalog components whether your application is for EMC shielding, ruggedization or highly customized. Whether it is a portable, desk-mount or rack-mount application, or whether it is a CompactPCI, VME or proprietary application, the Schroff case family has an off-the-shelf solution.

Systems—from a single source

Our comprehensive and highly developed product range offers you mechanical, electronic and thermal components with an extensive choice of dimensions and performance specifications. Simply select a complete, ready system or configure your system from our standard components to your exact requirements. With all resources under one roof, we ensure that backplane, power supply, cooling and mechanics form an optimized system.

Subracks—a modular toolbox

Schroff subracks, with their modular construction, offer you many profitable advantages, both technical and economic. Their standard components are offered with a vast range of supporting accessories for light-duty or heavy-duty applications. Whether for CompactPCI, VME64x or AdvancedTCA specifications, HF-shielded or rugged, the Schroff subrack system allows versatile combinations, letting you implement a range of versions in varying height, width and depth, simply, cost-effectively and with no design outlay.

Front panels—products plus services for any requirement

Offering a broad range of front panel products designed to industry-leading specifications, Schroff meets your application needs. With advanced customization services for all front panel product lines, and the Front Panel Express service, you can rely on the Schroff brand to solve your design requirements. Moreover, high-speed milling machines and stamping presses support low to very high volume front panel projects quickly.

Retainers—design flexibility for any requirement

Choose different wedge segments, lengths, individual wedge dimensions; relocate or add mounting holes, or even different hardware, materials and finishing. Calmark and Birtcher brand retainers offer an extremely broad range of configurations allowing you to meet your application needs.

Front Panels, Plug-in Units

Overview

- **Solutions for every application**

Schroff front panels meet all standards required for VME, CPCI, ATCA and mTCA applications. Ordering parts from Schroff will ensure that you have components which meet the highest industry standards.

- **Quality products modified to meet your needs**

Quality design and manufacturing processes back up our world class modification services—get the right product exactly how you need it.

- **Quick turn around for modifications**

Use our five business day Front Panel Express service to get custom front panels to meet your particular requirements. Please find more information at www.schroff.us/fpx

- **EMI shielded front panels**

Ensuring that all front panels have good EMI shielding will ensure that your overall system is properly shielded.

- **Peace of mind**

Ordering Front Panels from Schroff will ensure that you have one facility responsible for machining and screening your parts.

- **Industry leadership**

Active member in global standardization committees like IEC, IEEE, VITA, PICMG

Plug-in Units

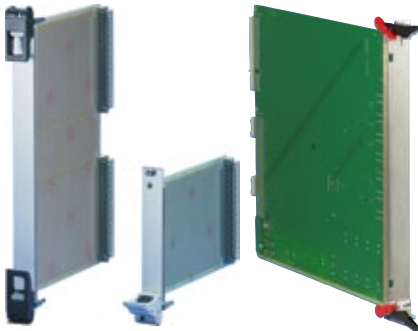

- Plug-in units available as kits or individual components
- Meets IEC 60297-3-101/IEEE 1101.1/11, IEC 60297-3-102/IEEE 1011.10 and IEC 60297-3-103 standards
- Front panels and front handles in different designs:
 - Heavy-load XL insertion/extractor handles, extraction force up to 1500 N
 - Cantilever extraction handle
 - Extraction handles for Multibus® II
 - Shielded insertion/extractor handles (1101.1)
 - Front panel kits with AdvancedTCA-IEA handles
- Nine different handles for plug-in units offering flexibility on application level
- EMC shielding available as application requires

Front Panels



- We offer the widest range of front panels to fit in subracks and cases
- Meets IEC 60297-3-101 / IEEE 1101.1/10 standards
- Extensive standard range with various aluminum finishes
- Front Panel Express: Fast delivery for customized versions (ready for dispatch within 5 to 10 days)
- EMC shielding available as application requires

AdvancedMC-Modules AMC.0 R2.0

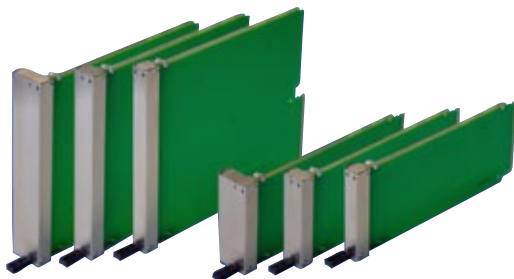

- AdvancedMC Modules: physical components
- Front panels with two locking mechanisms suitable for AdvancedMC carriers and MicroTCA systems
- Front panels in stainless steel or aluminium profile
- AdvancedMC Module Dimensions: Two heights (single and double); three widths (compact, mid-size and full-size)
- Ruggedized AdvancedMC Modules for MicroTCA.1 applications
- MicroTCA filler modules with adjustable air throughput
- Front panel sets with AdvancedTCA handles and AdvancedMC modules that support Telecom technologies

Front Panels

Front Panel Selection Guide

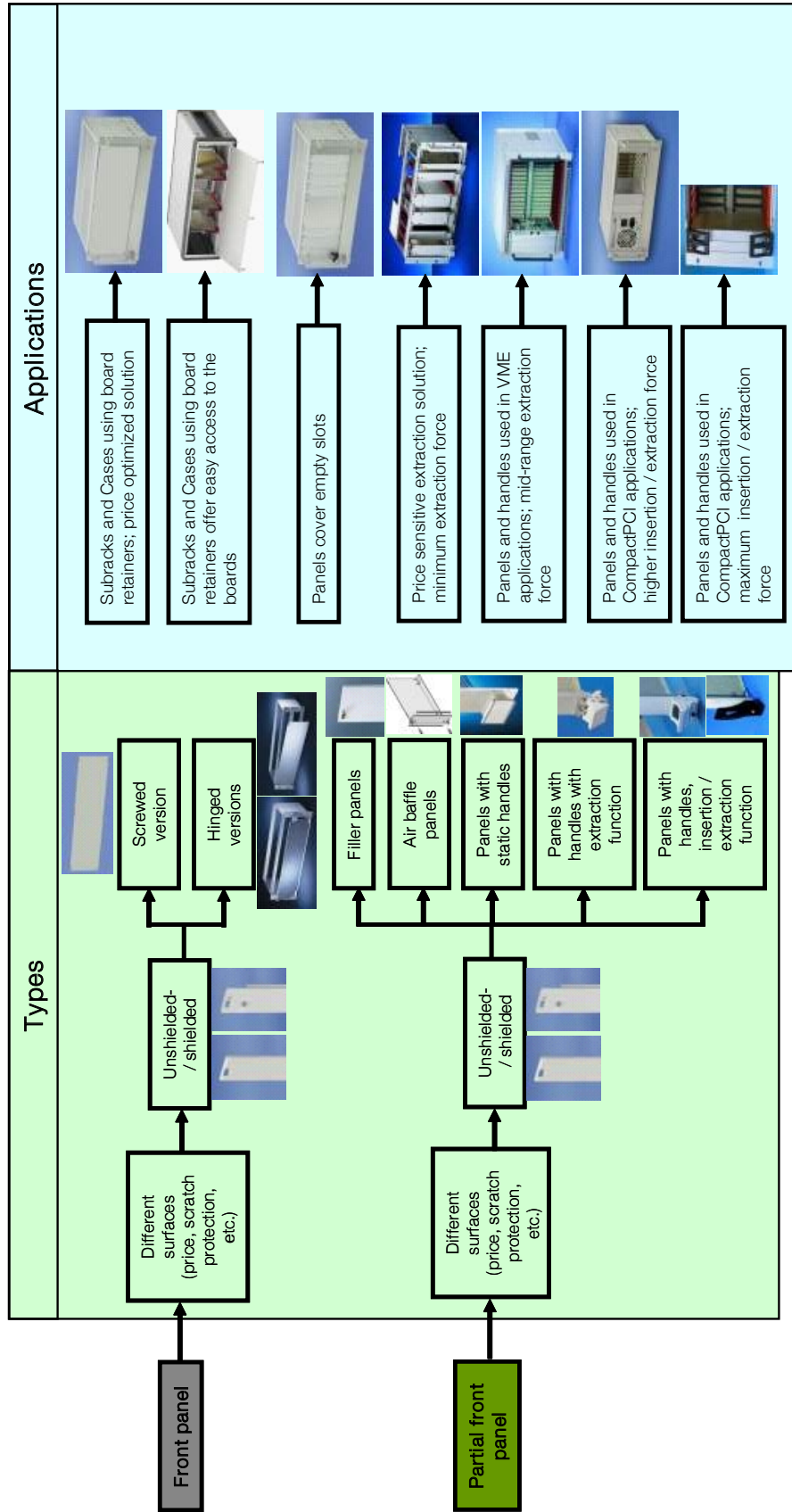

Front Panels

Front Panel Express—when customized panels are required - FAST!



Schroff Front Panel Express service offers fast prototypes-to-production cycle time. With Front Panel Express, you can get 5 to 50 front panels modified with custom cut-outs, handles and silk-screen in as few as 5 working days. Front Panel Express is available on several Schroff brand modified front panels. Solve your design problems and get your business up and running faster with Schroff brand products.

Advantages and Features:

- **Fast prototypes to production**—shipped in as few as 5 days
- **Broad** range of rugged front panel products available
- **Customization services** include cut-outs, screen printing, assembly and more
- **Local and global** design and product support
- **Design and engineering technical assistance** (Pro-E, SDRC, AUTOCAD and SolidWorks)



Advanced MC



Advanced TCA



PMC



VME



COMPACT PCI and VME64x

Preparing Your Design

1. Modify your drawing
2. E-mail your drawing to your local sales representative and we'll do the rest—fast.

Don't know who your sales representative is?

Visit schroff.us/contact

Industries

- Telecommunications
- Medical
- Defense
- Aerospace
- Test & measurement
- Industrial automation

Versatile Solutions from the Authority in Front Panel Technology

For more than 60 years, companies have relied on Schroff for product and service solutions for enclosing, protecting and cooling electrical and electronic systems. The Schroff brand offers world-leading electronics packaging components and systems, including versatile and robust front line products. To contact your local representative or learn more, visit schroff.us/fpx/

Front Panels

Front Panels, unshielded



- Front panels, aluminum, 2.5 mm
- Versions:
 - Aluminum, anodized
 - Aluminum, anodized, cut edges plain
 - Aluminum, front anodized, rear conductive coating

Standard Product

Height (U)	H (mm)	Width (HP)	B (MM)	b1 (MM)	b2 (MM)	Anodized, cut edges unplated	Anodized	Front anodized, rear conductive coating
3	128.4	4	20.0	–	–	30818-273	30807-481	30838-043
3	128.4	6	30.1	–	–	30818-275	30807-482	30838-045
3	128.4	8	40.3	25.4	–	30818-277	30807-484	30838-047
3	128.4	12	60.6	45.7	–	30818-281	30807-485	30838-051
3	128.4	28	141.9	127.0	–	30818-296	30807-496	30838-067
3	128.4	42	213.0	198.1	101.6	30818-310	30807-494	30838-081
3	128.4	63	319.7	304.8	157.5	30818-331	30808-067	30838-102
3	128.4	84	426.4	411.5	203.2	30818-352	30807-506	30838-123
4	172.9	84	426.4	411.5	203.2	30818-434	30807-596	30847-465
6	261.8	4	20.0	–	–	30818-518	30807-778	30838-124
6	261.8	6	30.1	–	–	30818-520	30807-752	30838-126
6	261.8	8	40.3	25.4	–	30818-522	30807-779	30838-128
6	261.8	12	60.6	45.7	–	30818-526	30807-755	30838-132
6	261.8	28	141.9	127.0	–	30818-542	30807-766	30838-148
6	261.8	42	213.0	198.1	101.6	30818-556	30807-764	30838-162
6	261.8	63	319.7	304.8	157.5	30818-577	30807-771	30838-183
6	261.8	84	426.4	411.5	203.2	30818-598	30807-776	30838-204

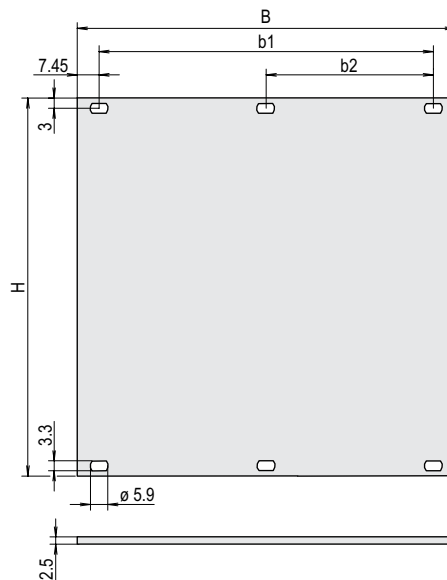

Front Panels

Front Panels, U profile, shieldable



Front panel with textile EMC-gaskets.
(EMC gasket purchased separately.)

- The textile EMC gaskets are fixed to the front panel at the right-hand side of the profile
- Temperature range -40 C to +70 C

Standard Product

Height H (U)	Width (mm)	Width (HP)	B (mm)	b1 (mm)	b2 (mm)	Alignment pin	Part no.
2	84	84	426.4	411.5	203.2	–	20848-262
3	128.4	2	9.8	–	–	x	30849-001
3	128.4	4	20	–	–	x	30848-354
3	128.4	6	30.1	–	–	x	30848-380
3	128.4	8	40.3	25.4	–	x	30848-356
3	128.4	12	60.6	45.7	–	x	30848-358
3	128.4	28	141.9	127	–	x	20848-027
3	128.4	42	213	198.1	101.6	x	20848-047
3	128.4	63	319.7	304.8	157.5	x	20848-068
3	128.4	84	426.4	411.5	203.2	–	20848-097
4	172.9	84	426.4	411.5	203.2	–	20848-271
6	261.8	4	20	–	–	x	30848-355
6	261.8	6	30.1	–	–	x	30848-381
6	261.8	8	40.3	25.4	–	x	30848-357
6	261.8	12	60.6	45.7	–	x	30848-359
6	261.8	28	141.9	127	–	x	20848-120
6	261.8	42	213	198.1	101.6	x	20848-139
6	261.8	63	319.7	304.8	157.5	x	20848-160
6	261.8	84	426.4	411.5	208.3	–	20848-189

Accessories

Textile EMC gaskets, Height 3 U, 97 mm, Qty. 10 pieces	21101-853
Textile EMC gaskets, Height 3 U, 97 mm, Qty. 100 pieces	21101-854
Textile EMC gaskets, Height 6 U, 232 mm, Qty. 10 pieces	21101-855
Textile EMC gaskets, Height 6 U, 232 mm, Qty. 100 pieces	21101-856

Part number in bold face is a stocked item.

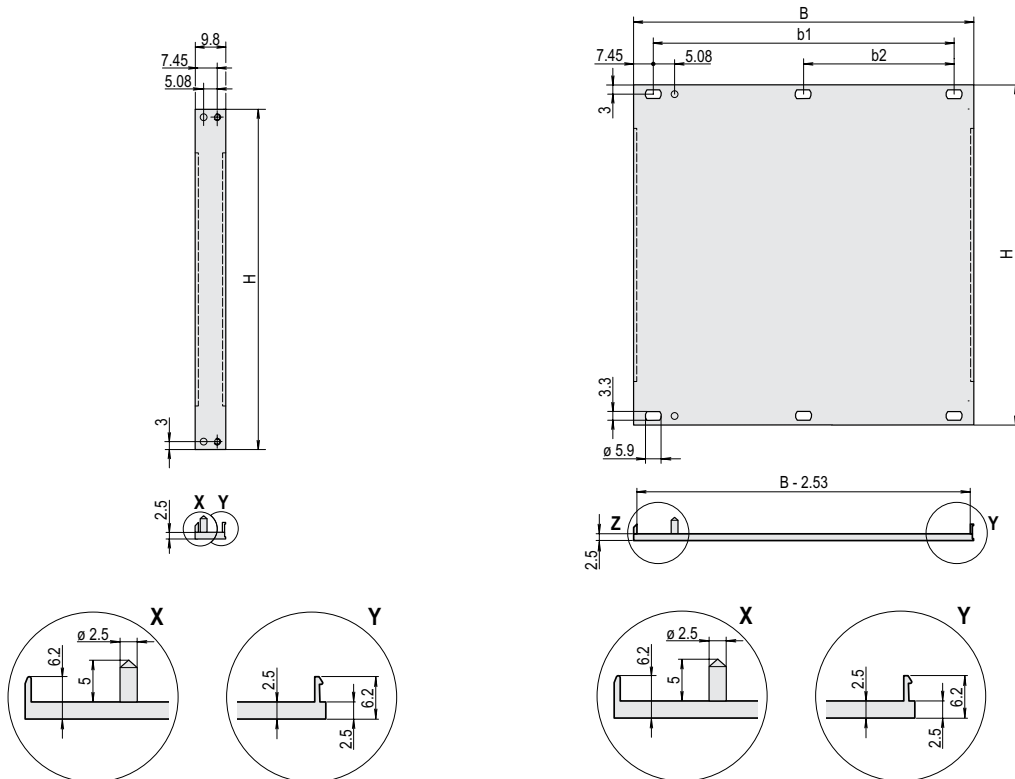

Front Panels

PMC Mezzanine Front Panels with handle, shielded

- PMC= PCI Mezzanine Card
- For module size 194 x 74 mm²
- Meets IEEE P1386 standard
- 6 U / 4 HP front panels with EMC sealing (stainless steel) and front handles

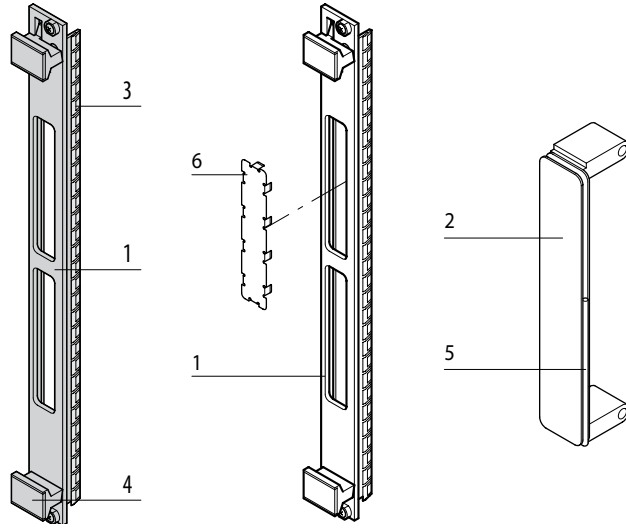

#1 Front panel

#2 EMC gasket

#3 Handle

Standard product

Item	Description	Qty.	Part no.
1+2+3	PMC mezzanine front panel with handle, shielded	1	20897-950

Accessories

Item 6	EMC cover for PMC mezzanine front panel cut-outs, stainless steel, 0.2 mm, black, 1 piece (Qty. 10)	60835-024
Item 6	EMC cover for PMC mezzanine front panel cut-outs, stainless steel, 0.2 mm, bright, 1 piece (Qty. 10)	60835-022
Item 2	PMC mezzanine front panels, aluminium extrusion, anodized, conductive contact surfaces, 1 piece	20835-598
Item 2	PMC mezzanine front panels, zinc die-cast, black, chromated, 1 piece	20835-922
Item 2	PMC mezzanine front panels, zinc die-cast, chrome-plated, mat, 1 piece	20835-923
Cheesehead screw M2.5 x 5 mm, Qty. 100 pieces		21100-624

Part number in bold face is a stocked item.

Cantilever Extraction Handles

Type 2 plastic static handle	Type 2 plastic extraction handle for notched front panel	Type 2 plastic extraction handle, standard C style	Extraction handles for Multibus® II standard	Plastic extraction handles - short lever	Plastic extraction handles - long lever

Available as spare parts or in kit form.

Plug-In Units

Plug-In Unit Kits for AdvancedTCA-IEA with die-cast end piece handles



(Board not included) (AdvancedTCA spring-loaded IEA handle)

- Hot-swap handles (spring-loaded)
- Front panels: aluminum extrusion or stainless steel
- Die-cast end piece (top and bottom) to increase stability of front panel
- EMC sealing (textile)

Standard Product

Height (U)	Width (HP)	Description	Part no.
8	6	Stainless steel, with AdvancedTCA-IEA handle (plunger type)	20818-160
8	6	Stainless steel, with AdvancedTCA-IEA handle (lever type)	20818-161
8	6	Al extrusion, 1 mm, with AdvancedTCA-IEA handle (plunger style)	20818-169
8	6	Al extrusion, 1 mm, with AdvancedTCA-IEA handle (lever style)	20818-170

Plug-In Unit Kits for CompactPCI and VME64x applications



- Meets IEEE 1101.10 and IEC 60297-3-102 standards
- Codable to IEC 60297-3-103
- Shielded front panels
- Suitable for insertion and extraction forces up to 700 N (per pair)
- Designed for fitting microswitches

Standard Product

Height (U)	Width (HP)	Part no. Front Assembly	Part no. Rear I/O
3	4	20848-585	20848-751
3	6	20848-587	-
3	8	20848-589	20848-752
3	10	20848-590	-
3	12	20848-591	-
6	4	20848-592	-
6	6	20848-594	-
6	8	20848-596	-
6	10	20848-597	-
6	12	20848-598	-

Accessories

Microswitch for handles, CompactPCI/VME64x application, Qty. 10 pieces	20817-606
--	-----------

Part number in bold face is a stocked item.

Plug-In Units

Plug-In Unit Kits with cantilever extraction handle type 2 for VME applications



(Board not included)

- Unshielded

Standard Product

Height (U)	Width (HP)	Part no.
3	4	20817-860
3	6	20817-862
3	8	20817-864
3	12	20817-866
6	4	20817-867
6	6	20817-869
6	8	20817-871
6	12	20817-873

AdvancedMC-Modules with Pull-Handle Mechanism for PIGMG AMC.0 R2.0 applications

(Photo shows steel front panel with complete module)

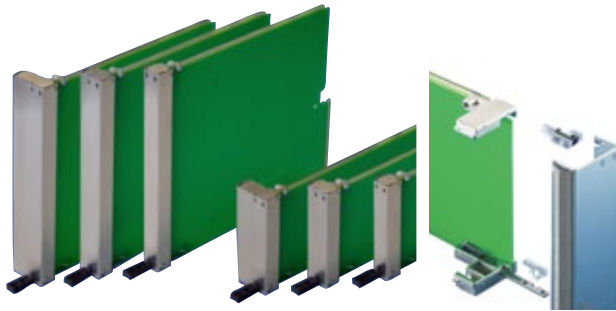

- Shielded
- Insertion/extraction mechanism to AdvancedMC standard; pull handle to extract sub-assembly
- For conventional, cutaway and hybrid carriers
- Designed for microswitch activation (hot-swap); interlocking of modules without screws
- Inclusive of light pipe
- Stainless steel front panel is available on request
- Aluminium profile front panel for foil labelling

Standard Product

H (mm)	h (mm)	Description	Part no. Aluminium
73.8	60.8	Single compact, 3 HP	20849-312
73.8	60.8	Single mid-size, 4 HP	20849-268
73.8	60.8	Single full-size, 6 HP	20849-270
148.8	135.8	Double compact, 3 HP	20849-313
148.8	135.8	Double mid-size, 4 HP	20849-269
148.8	135.8	Double full-size, 6 HP	20849-271

Accessories

Microswitch for AdvancedMC modules normally open, for soldering (SMD), Qty. 10 pieces	20849-209
---	-----------

Subracks

Overview

Subrack Features

- **Subrack products for every application**

19-in. and 23-in. rack-mount equipment, embedded electronics, test equipment, security and defense industry solutions—Schroff provides the widest range of subrack products in the industry.

- **Quality products modified to meet your needs**

Quality design and manufacturing processes back up our world class modification services—get the right product exactly how you need it.

- **Unmatched electromagnetic shielding performance**
The strongest chassis level electromagnetic shielding available on the market—as a standard upgrade.
- **Rugged and robust components**
Designed to meet industry standards for shock and vibration applications.
- **Integration beyond the metal**
Schroff is the expert at integrating to any level you require. Get electronics, wiring, backplanes, power and cooling all from one supplier.
- **Industry leadership**
Active member in global standardization committees like IEC, IEEE, VITA, PICMG.

europacPRO



- 19-in. subracks with high design flexibility
- Can be configured to meet a full range of applications and customer requirements from the most basic configuration to Military Spec, Rugged
- Meets IEC 60297-3-103 and IEEE 1101.10/11 standards
- Available in kit or complete assembly

inpac



- 19-in. chassis with high mechanical stability
- Flexible construction for standard board formats or individual solutions
- Can be used as a desktop enclosure

multipacPRO

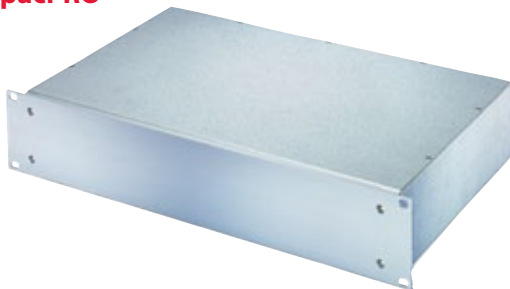

- 19-in. chassis for non-standard components and horizontal board applications
- Versions in steel or aluminum
- Available in kit or complete assembly

Subracks

Subrack Selection Guide



Some limitations apply; please see www.schroff.us/fpx/ for more details.

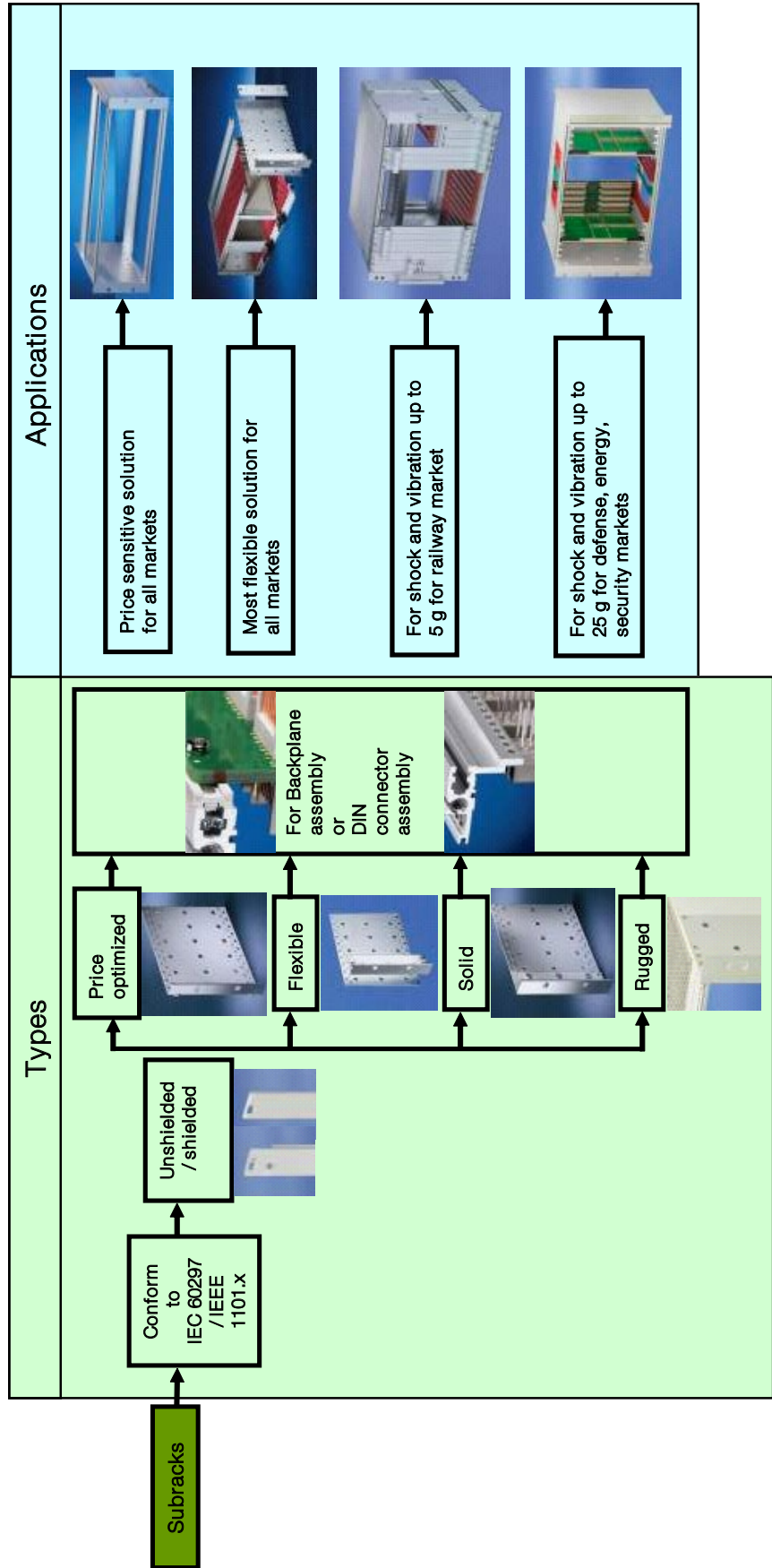

Subracks

europacPRO—Kits, unshielded, for backplane mounting

- 19-in. subracks with high design flexibility
- Rear horizontal rail for backplane mounting with insulation strip

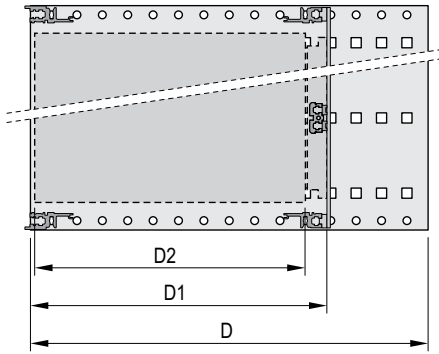
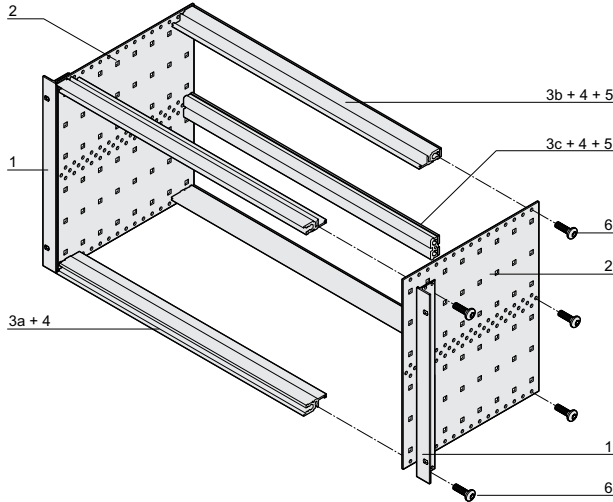

(D=total depth, D1=insertion depth, D2=board depth)



(Rear horizontal rail for backplane mounting with insulation strip)

Standard Product

Height (U)	Width (HP)	Depth D (mm)	Depth D1 (mm)	Depth D2 (mm)	Part no.
3	84	175	175	160	24563-131
3	84	235	175/235	160/220	24563-132
3	84	295	175/235/295	160/220/280	24563-133
3	84	355	175/235/295/355	160/220/280/340	24563-134
3	84	415	175/235/295/355	160/220/280/340	24563-135
3	84	475	175/235/295/355	160/220/280/340	24563-136
6	84	175	175	160	24563-431
6	84	235	175/235	160/220	24563-432
6	84	295	175/235/295	160/220/280	24563-433
6	84	355	175/235/295/355	160/220/280/340	24563-434
6	84	415	175/235/295/355	160/220/280/340	24563-435
6	84	475	175/235/295/355	160/220/280/340	24563-436

Accessories

Front handle 3 U, clear anodized, 1 piece	10501-005
Front handle 6 U, clear anodized, 1 piece	10501-008
Guide rails, 160 mm deep, PBT, UL 94 V-0, red, groove width 2 mm, Qty. 10 pieces	24560-351
Guide rail, 220 mm deep, PBT, UL 94 V-0, red, groove width 2 mm, Qty. 10 pieces	24560-353
Guide rail, 280 mm deep, PBT, UL 94 V-0, red, groove width 2 mm, Qty. 10 pieces	24560-379
Guide rail, 340 mm deep, PBT, UL 94 V-0, red, groove width 2 mm, Qty. 10 pieces	24560-380
ESD clip for guide rails, Qty. 50 pieces	24560-255
19-in. assembly kit (screw, washer, nut) (8 × screws, 8 × plastic washers, 8 × cage nuts)	21100-435

Kit includes:

Item	Qty.		Description
	3 U	6 U	
1	2	2	19-in. support bracket for stainless steel EMC gasket
2	2	2	Side panel type F
3a	2	2	Front horizontal rail
3b	2	2	Rear horizontal rail for backplane mounting with insulation strip
3c	-	1	Center horizontal rail
4	4	6	Threaded inserts, to front and rear, pre-fitted
5	2	4	Insulation strip (pre-fitted)
6	1	1	Assembly kit
7	1	1	User manual

Part number in bold face is a stocked item.

Subracks

europacPRO—Kits, shielded, for backplane mounting

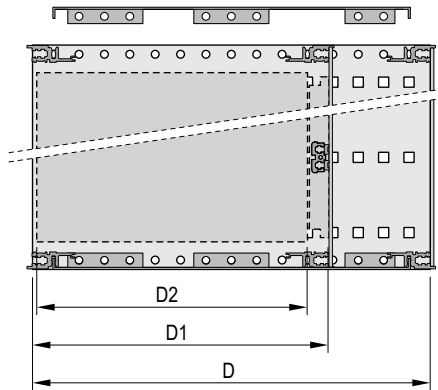
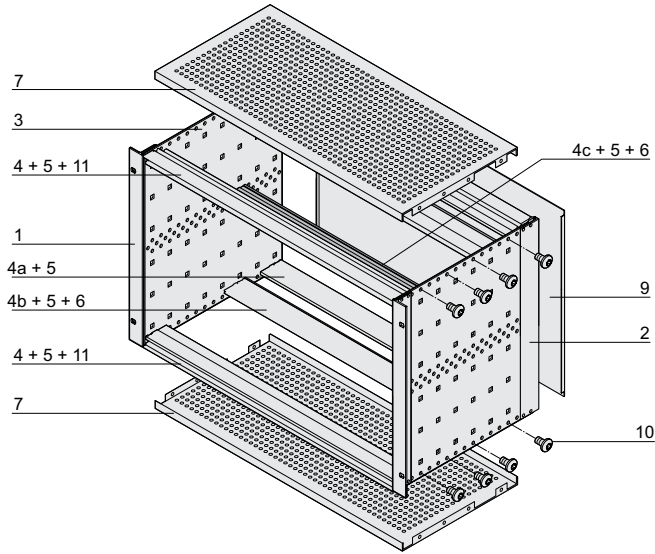
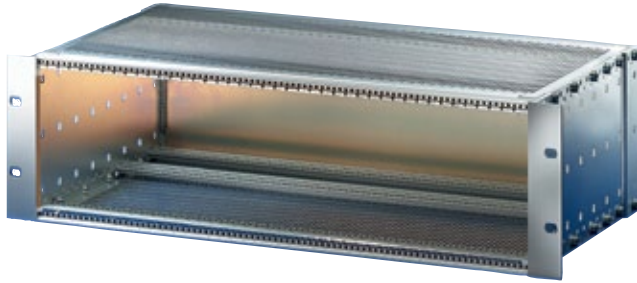

(D=total depth, D1=insertion depth, D2=board depth)



(Rear horizontal rail for backplane mounting with insulation strip)

- 19-in. subracks with high design flexibility
- Horizontal rail at rear for backplane mounting with insulation strip
- Shielding typically 40 dB at 1 GHz, 30 dB at 2 GHz (to VG 95373, part 15 or IEC 61587, part 3), provided the front is closed with shielded front panels

Standard Product

Height (U)	Width (HP)	Depth D (mm)	Depth D1 (mm)	Depth D2 (mm)	Part no.
3	84	235	175/235	160/220	24563-142
3	84	295	175/235/295	160/220/280	24563-143
3	84	355	175/235/295	160/220/280	24563-144
3	84	415	175/235/295	160/220/280	24563-145
3	84	475	175/235/295	160/220/280	24563-146
6	84	235	175/235	160/220	24563-442
6	84	295	175/235/295	160/220/280	24563-443
6	84	355	175/235/295	160/220/280	24563-444
6	84	415	175/235/295	160/220/280	24563-445
6	84	475	175/235/295	160/220/280	24563-446

Accessories

Front handle 3 U, clear anodized, 1 piece	10501-005
Front handle 6 U, clear anodized, 1 piece	10501-008
Guide rails , 160 mm deep, PBT, UL 94 V-0, red, groove width 2 mm, Qty. 10 pieces	24560-351
Guide rail , 220 mm deep, PBT, UL 94 V-0, red, groove width 2 mm, Qty. 10 pieces	24560-353
Guide rail , 280 mm deep, PBT, UL 94 V-0, red, groove width 2 mm, Qty. 10 pieces	24560-379
ESD clip for guide rails Qty. 50 pieces	24560-255
19-in. assembly kit (screw, washer, nut) (8 × screws, 8 × plastic washers, 8 × cage nuts)	21100-435

Kit includes:

Item	Qty		Description
	3 U	6 U	
1	2	2	19-in. support bracket for EMC gasket (textile)
2	2	2	Rear corner profile for EMC gasket (textile)
3	2	2	Side panel
4	2	2	Front horizontal rail
4a	2	2	Rear horizontal rail
4b	2	2	Rear horizontal rail for backplane mounting with insulation strip
4c	-	1	Center horizontal rail
5	6	8	Threaded insert (pre-fitted)
6	2	4	Insulation strip, fixed
7	2	2	EMC cover plate
8	1	1	EMC gasketing material (pre-fitted)
9	1	1	Rear panel
10	1	1	Assembly kit
11	2	2	Perforated strip (pre-mounted)
12	1	1	User manual

Part number in bold face is a stocked item.

Sub racks

europacPRO—Kits, shielded, for CompactPCI with backplane mounting for rear I/O

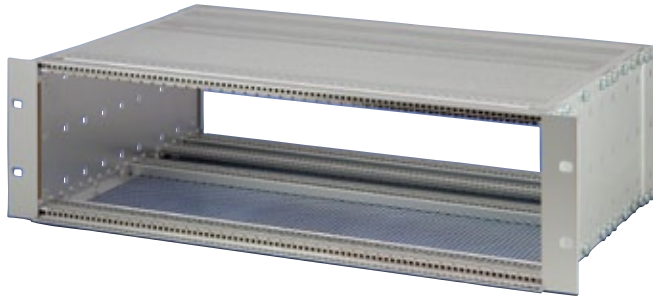

- 19-in. flexible subracks for CompactPCI plug-in units with high insertion and withdrawal forces, meets IEEE 1101.10/11 and IEC 60297-3-103
- For rear I/O boards (depth 80 mm)
- Horizontal rail at rear for backplane mounting with insulation strip
- Shielding typically 40 dB at 1 GHz, 30 dB at 2 GHz (to VG 95373, part 15 or IEC 61587, part 3), provided the front is closed with shielded front panels

Standard Product

Height (U)	Width (HP)	Depth D (mm)	Depth D1 (mm)	Depth D2 (mm)	Depth D3 (mm)	Part no.
3	84	275	175	160	80	24563-157
6	84	275	175	160	80	24563-457

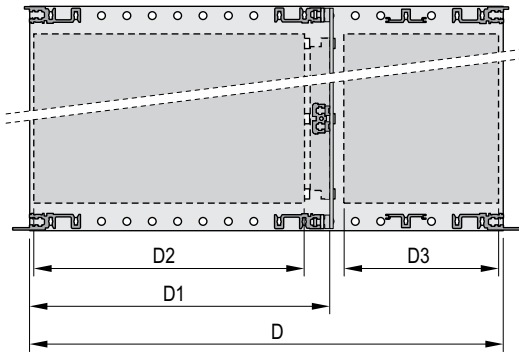
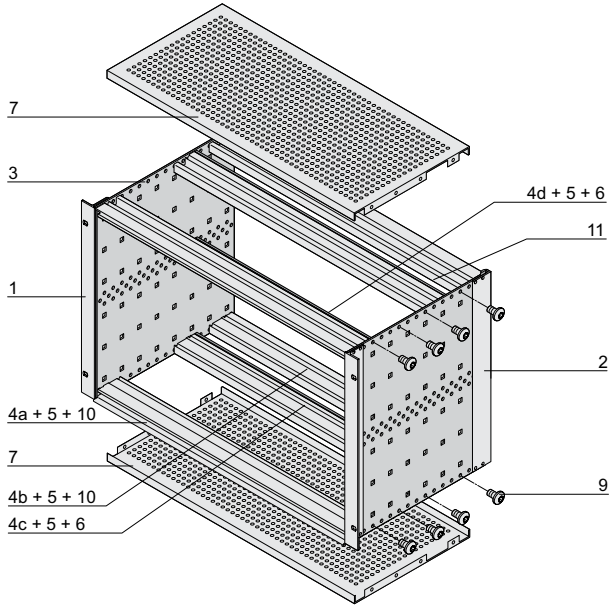

(D=overall depth, D1=insertion depth, D2=board depth, D3=board depth rear I/O))



(Rear horizontal rail for backplane mounting with insulation strip)

Accessories

Front handle 3 U, clear anodized, 1 piece	10501-005
Front handle U, clear anodized, 1 piece	10501-008
Guide rails with coding, red 70 mm deep, Qty. 10 pieces	24560-355
Guide rails with coding, gray 70 mm deep, Qty. 10 pieces	24560-360
Guide rails with coding, red 160 mm deep, PBT, UL 94 V-0, groove width 2 mm, Qty. 10 pieces	24560-356
Guide rails with coding, gray 160 mm deep, PBT, UL 94 V-0, groove width 2 mm, Qty. 10 pieces	24560-358
Guide rails with coding, green, offset 160 mm deep, PBT, UL 94 V-0, groove width 2 mm, Qty. 10 pieces	24560-359
ESD clip for guide rails Qty. 50 pieces	24560-255
ESD clip for alignment pin of CPCI/VME64x handle Qty. 50 pieces	24560-256
Torx Panhead screw 2.5 × 9.3, zinc-plated, Qty. 100 pieces	24560-141
Coding pin PC, UL 94 V-0, RAL 7035, Qty. 100 pieces	20817-501
19-in. assembly kit (screw, washer, nut) (8 × screws, 8 × plastic washers, 8 × cage nuts)	21100-435

Kit includes:

Item	Qty.	3 U	6 U	Description
1	2	2		19-in. support bracket for EMC gasket (textile)
2	2	2		Rear corner profile for EMC gasket (textile)
3	2	2		Side panel
4	1	-		Front horizontal rail
4a	1	2		Front horizontal rail IEEE
4b	2	2		Rear horizontal rail
4c	2	2		Rear horizontal rail with insulation strip for backplane mounting
4d	-	1		Centre horizontal rail
5	6	8		Threaded insert (pre-fitted)
6	2	4		Insulation strip, fixed
7	2	2		EMC cover plate
8	1	1		EMC gasketing material (pre-fitted)
9	1	1		Assembly kit
10	2	2		Perforated strip (pre-mounted)
11	2	2		Horizontal rail
12	1	1		User manual

Part number in bold face is a stocked item.

Subracks

Guide Rails for plug-in units and modules

Assemblies can be clipped into aluminum extruded horizontal rails and 1.5 mm thick plates.

Storage temperature from -40 C to 130 C.

Standard Product



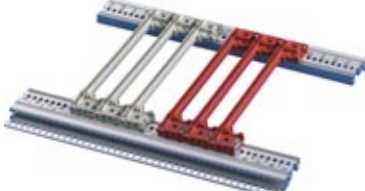



Board lengths (mm)	Groove width (mm)	Color	1 piece (Qty. 50) ¹⁾	Qty. 10 pieces
70	2	red	34579-230	24560-355
70	2	gray	34579-231	24560-360
160	2	red	64560-001	24560-356
160	2	gray	–	24560-358
220	2	red	64560-002	–

For standard plug-in units and frame type plug-in units for 2 HP wide application	For CompactPCI, VME64x with coding for 4 HP wide application, meets IEEE 1101.10 and EIC 60297-3-103 Standards
 <p>PBT, UL 94 V-0</p>	 <p>one-piece for groove width 2 mm, PBT, UL 94 V-0 multi-piece for groove width 2.5 mm, end piece PBT, UL 94 V-0; middle section Al extrusion multi-piece for groove width 2.5 mm, end piece PBT, UL 94 V-0; middle section Al extrusion</p>

¹⁾ SPQ (standard pack quantity): Order number includes 1 piece, but delivery is exclusively made in standard pack quantity (SPQ); please order at least the SPQ quantity or a multiple thereof

Horizontal Boards mounting in 3 or 4 U subracks

Standard Product

Height (U)	Usable height h (HP)	Horizontal rail, front	Horizontal rail, rear*	Qty. 1 kit
3	20			24564-117
3	20			24564-118
4	28			24564-217

*For direct backplane mounting

Subracks

Divider Plates

Standard Product

					Divider Plates	
					Mounting position for stainless steel EMC gasket	Mounting position for textile EMC gasket
Stainless steel, 1 mm, mounted by clipping onto horizontal rail; space requirement on component side 2 mm; mounting direction varies with shielding design (EMC stainless steel or textile gasket); retrofitting the divider plate in an already-assembled subrack/case will first require dismantling the horizontal rails; where front panels are unshielded both mounting directions are possible Al extrusion, passivated						
Height (U)	Depth (mm)	A (mm)	B (mm)	H (mm)	Qty. 10 pieces	
3	160	158.3	135.0	113.5	34562-761	
3	220	218.3	195.0	113.5	34562-762	
6	160	158.3	135.0	246.9	34562-763	
6	220	218.3	195.0	246.9	34562-764	

Mounting Plates

Standard Product

			Mounting Plate can be used in combination with cover plates	Mounting Plate for fixing heavy components	
			Al, 1.5 mm; mounting is only possible over the entire width between the side panels	Al, 1.5 mm; for mounting over partial width; please order assembly strips separately	St, 2 mm, zinc-plated; is bolted from front to rear onto the horizontal rails; to fix mounting plates
Width W (HP)	W (mm)	Board Lengths (mm)	Qty. 1 piece	Qty. 1 piece	Qty. 1 piece
28	146.88	160	34563-001	34562-745	30840-021
28	146.88	220	34563-009	34562-749	30840-033
42	217.99	160	34563-002	34562-746	30840-021
42	217.99	220	34563-014	34562-750	30840-033
63	324.67	160	34563-003	34562-747	30840-021
63	324.67	220	34563-019	34562-751	30840-033
84	431.35	160	34563-004	34562-748	30840-021
84	431.35	220	34563-024	34562-752	30840-033
Assembly kit for mounting plate, Qty. 1 kit (Torx countersunk screw M4 x 5, St, zinc-plated, 12 pieces; screw M4 x 6, St, zinc-plated 10 pieces; M4 square nut, St, zinc-plated, 10 pieces)		Part no. 24560-146	24560-184	24560-184	-

inpac—19-in. chassis

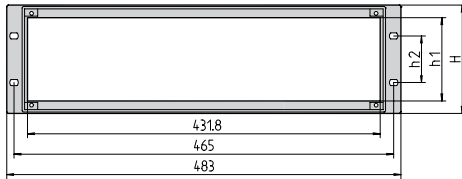
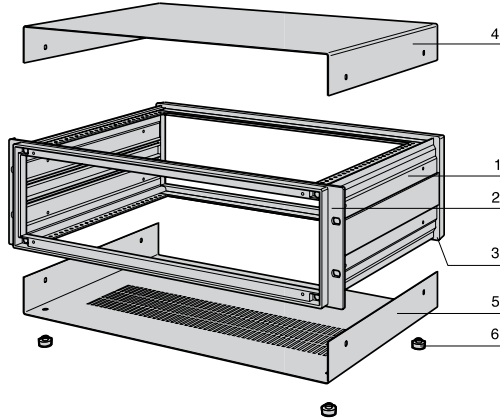

Support rail accessory: Item 1: Support rail front; Item 2: Support rail rear; Item 3: Guide rail 160/220 mm

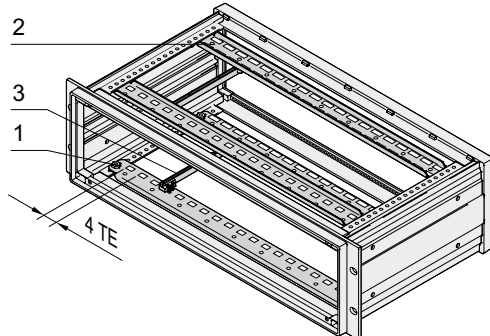

(TE = HP)

Subracks

- For assembly with 19-in. components or individually with mounting plate
- Three rows of ventilation slots in base for air inlet

Standard Product

Height H (U)	Height H (mm)	h (mm)	h1 (mm)	h2 (mm)	Depth D (mm)	Part no.
2	88.0	86.0	57.5	76.2	254.5	10828-071
2	88.0	86.0	57.5	76.2	314.5	10828-072
2	88.0	86.0	57.5	76.2	374.5	10828-073
3	132.5	130.5	102.0	57.1	254.5	10828-051
3	132.5	130.5	102.0	57.1	314.5	10828-052
3	132.5	130.5	102.0	57.1	374.5	10828-053
3	132.5	130.5	102.0	57.1	434.5	10828-054
4	177.0	174.5	146.5	101.6	254.5	10828-056
4	177.0	174.5	146.5	101.6	314.5	10828-057
4	177.0	174.5	146.5	101.6	374.5	10828-058
4	177.0	174.5	146.5	101.6	434.5	10828-059
6	265.9	263.5	235.4	190.5	374.5	10828-068
6	265.9	263.5	235.4	190.5	434.5	10828-069

Accessories

Front panels Al, 2 mm, anodized, height 2 U, width 437 mm, 1 piece	30828-055
Front panels Al, 2 mm, anodized, height 3 U, width 437 mm, 1 piece	30828-058
Front panels Al, 2 mm, anodized, height 4 U, width 437 mm, 1 piece	30828-061
Front panels Al, 2 mm, anodized, height 6 U, width 437 mm, 1 piece	30828-067
Rear panel with ventilation openings Al, 2.5 mm, anodized, height 2 U, width 437 mm, 1 piece	30828-070
Rear panel with ventilation openings Al, 2.5 mm, anodized, height 3 U, width 437 mm, 1 piece	30828-073
Rear panel with ventilation openings Al, 2.5 mm, anodized, height 4 U, width 437 mm, 1 piece	30828-076
Rear panel with ventilation openings Al, 2.5 mm, anodized, height 5 U, width 437 mm, 1 piece	30828-082
Support rail for guide rails front support rail, item 1, St, 1.5 mm, blue-passivated, 1 piece	30828-165
Support rail for guide rails rear support rail, item 2, St, 1.5 mm, blue-passivated, 1 piece	30828-174
Screw for support rail assembly, M4 × 8, flat head pozidrive, Qty. 100 pieces	21100-677
Guide rail 160 mm , item 3, groove width 2 mm, Qty. 1 pair	60817-078
Guide rail 220 mm , item 3, groove width 2 mm, Qty. 1 pair	60817-079
Guide rails Length 160 mm, groove width 2 mm, 1 piece	60817-103
Guide rails Length 220 mm, groove width 2 mm, 1 piece	60817-149
Grounding kit 1 piece	21100-814

Includes (Items 1, 2 and 3 assembled)

Item	Qty.	Description
1	2	Side panel, Al extrusion, RAL 7030 at 6 U: 2 Al corner profiles 1 divider plate (steel plate)
2	1	Front frame, Al die-cast, RAL 7030, rear side with counterbores for drill holes to mount handles and front panels
3	1	Rear frame, Al die-cast, RAL 7030
4	1	Cover plate, St, 1 mm, RAL 7035, plastic-coated, with grounding connection
5	1	Base plate, St, 1 mm, RAL 7035, plastic-coated, with grounding connection
6	4	Case foot with anti-slip protection, PC, UL 94 V-0
7	1	Assembly kit

Part number in bold face is a stocked item.

Subracks

multipacPRO—19-in. complete steel chassis, plain top cover and base plate

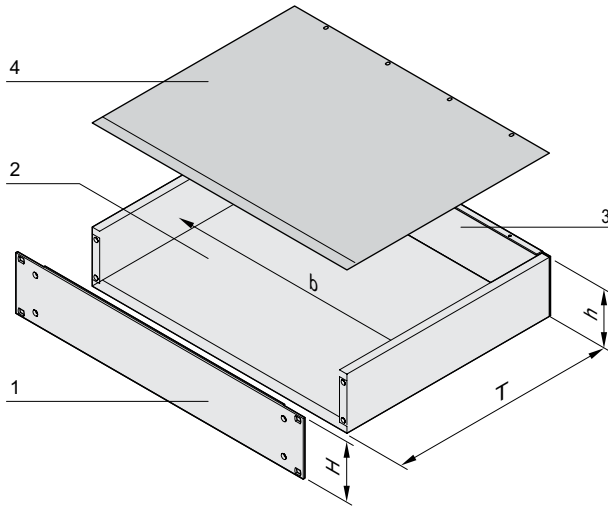
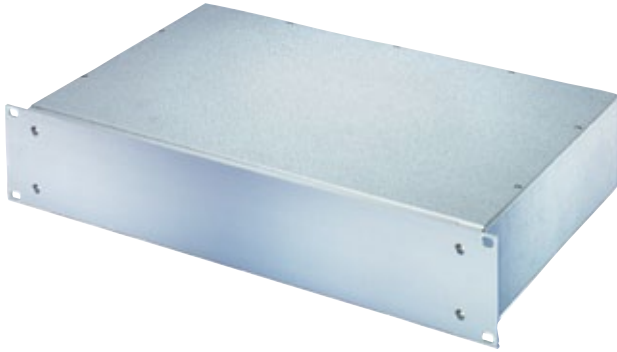

(h - clear height [overall]) (H - 3.0 mm)
(b = clear installation width)

- Complete chassis, St (AlZn coated) with Al extrusion front panel
- Detachable rear panel for easy machining
- EMC shielding of approximately 30 dB(A) at 1 GHz (without additional shielding material)
- Meets IEC 60297-3-100, 60297-3-101 and 60297-3-105 standards
- In the 1 U version, 19-in. and ATX power supplies can be assembled up to a clearance of 40 mm

Standard Product

Height (U)	Height H (mm)	Depth T (mm)	Part no.
1	43.6	220	20860-120
1	43.6	280	20860-121
1	43.6	340	20860-122
2	88.1	280	20860-126
2	88.1	340	20860-127

Accessories

	Front handles	20860-256
	incl. assembly kit for 1 U, Al extrusion, anodized, Qty. 2 pieces	
	Front handles	20860-257
	incl. assembly kit for 2 U, Al extrusion, anodized, Qty. 2 pieces	

Includes (kit)

Item	Qty.	Description
1	1	Front panel, Al extrusion, 3 mm; at 1 U: front anodized, rear etched; from 2 U: front and rear side of front panels clear passivated
2	1	Base body plain, St, 1 mm, (AlZn coated)
3	1	Rear panel, St, 1 mm (AlZn coated)
4	1	Cover plain, St, 1 mm (AlZn coated)
5	1	Assembly kit

Cases

Overview

Case Features

- **Electronics case products for every application**
Test and measurement equipment, medical equipment, portable electronics and rugged protection for field equipment
- **Modification to meet your specific needs**
Panels, I/O cutouts, equipment mounting plates, custom colors and screen printing
- **Highly effective electromagnetic shielding**
The strongest electromagnetic interference shielding available on standard case products

- **Robust and aesthetic**
Made from strong aluminum and steel materials, our cases are also attractive with a modern aesthetic look
- **Perfect combination of features**
Form and function for measurement, instrumentation and control technology in a wide range of industries
- **Always in front**
Active member in global standardization committees like IEC, IEEE, VITA, PICMG

comptec

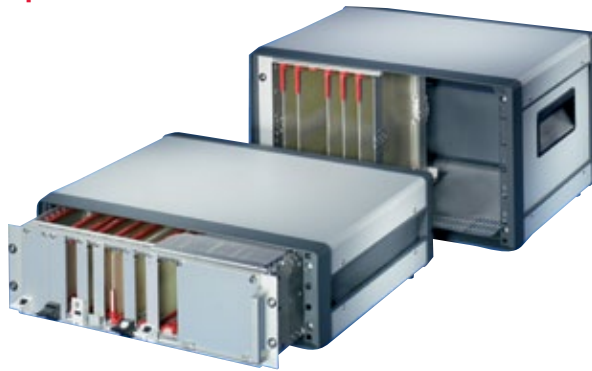

- High stability
- Mini-cabinets
- Desktop enclosures
- Mounts 19-in. equipment
- Lab and demo applications
- Steel or aluminum case

compacPRO



- For 19-in. components or individual electrical equipment
- Many standard sizes
- Rugged build
- Attractive
- Desktop case
- Aluminum case

ratiopacPRO



- Universal cases with 19-in. compatible dimensions, e.g., for CompactPCI and VME64x applications
- Feature rich
- Easy to modify
- Best EMC solution
- Desktop or rack mount
- Aluminum case

Cases

Cases Selection Guide



Some limitations apply; please see www.schroff.us/fpx/ for more details.

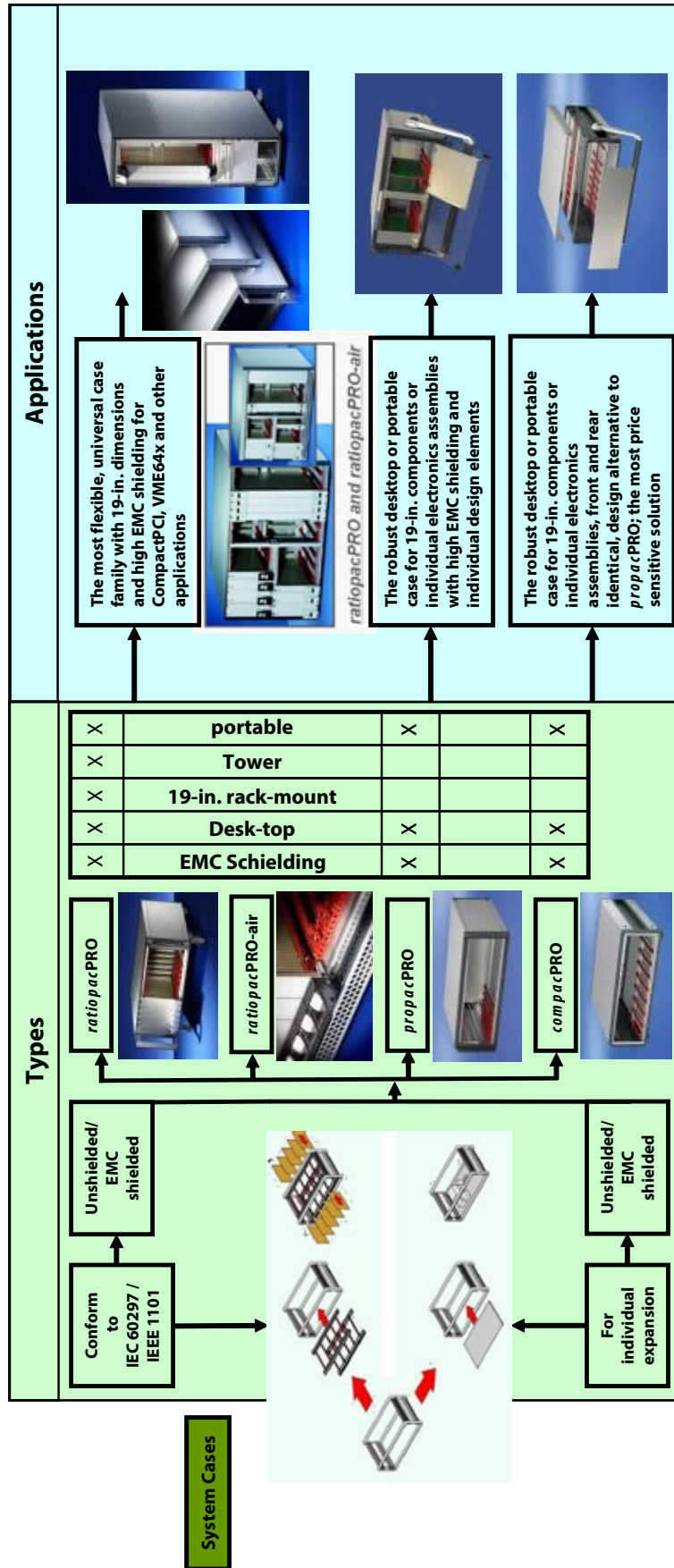

Cases

comptec—19-in. cases 3, 4, 6, 9 U



(Height 3 and 4 U)

(Height 6 and 9 U)

Front View

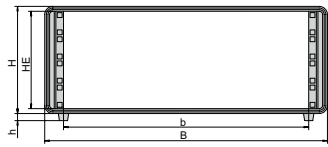

(h = case foot height, HE = U, internal usable height)

Front View

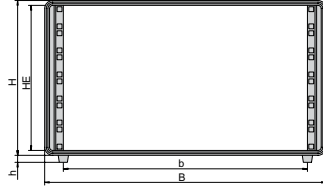

(h = case foot height, HE = U, internal usable height)

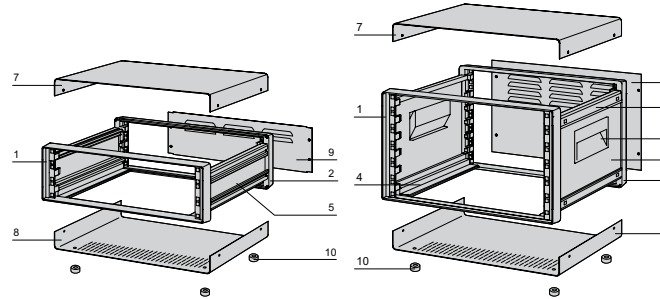

Side View

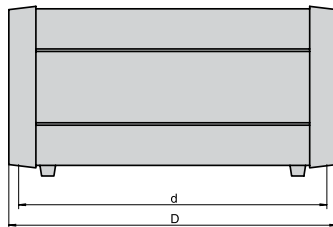

(Usable width $b = B - 69$ mm, h = height of case foot)

Side View

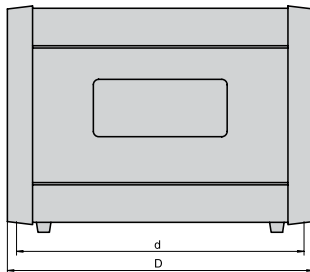

(Usable depth $d = D - 24$ mm)

- Accepts 19-in. rack-mount units
- Desktop enclosures (pre-assembled)
- Steel top covers, base plates and rear panels
- Al die-cast front and rear frames
- Ventilation slots in base plate, air vents in rear panel

Standard Product

Height H (U)	h (mm)	Depth D (mm)	Usable depth d (mm)	Width (mm)	Part no.	
3	153	13.0	300	276	520	10225-601
3	153	13.0	400	376	520	10225-612
3	153	13.0	500	476	520	10225-623
4	198	13.0	300	276	520	10225-602
4	198	13.0	500	476	520	10225-624
6	286	13	300	276	520	10225-604
6	286	13	400	376	520	10225-615
6	286	13	500	476	520	10225-626
6	286	13	600	576	520	10225-637
9	420	13	400	376	520	10225-618
9	420	13	500	476	520	10225-629
9	420	13	600	576	520	10225-640

Accessories

	Grounding kit for cases with steel covers , for 3, 4 U, Cu wire 1.5 mm ² , PVC sleeve, green/yellow, 1 kit	21100-490
	Grounding kit for cases with steel cladding , for 6, 9 U, Cu wire 1.5 mm ² , PVC sleeve, green/yellow, 1 kit	21100-448
	Slide rails for 300 mm case depth, 1 piece	30225-089
	Slide rails for 400 mm case depth, 1 piece	30225-090
	Slide rails for 500 mm case depth, 1 piece	30225-091
	Slide rails for 600 mm case depth, 1 piece	30225-092

Includes (kit) (6, 9 U; 3, 4 U without item 3, 4, 6)

Item	Qty	Description
1	1	Front frame, Al die-cast, RAL 7016, with 19-in. grid
2	1	Rear frame, Al die-cast, RAL 7016, with 19-in. grid
3	2	Side profile at top, Al extrusion, RAL 7016
4	2	Side profile at bottom, Al extrusion, RAL 7016
5	2	Side panel, St, 1.5 mm, RAL 9006, with grounding tag
6	2	Handle shell, PC, RAL 7016, UL 94 V-0, load-carrying capacity: 60 kg/pair
7	1	Cover plate, St, 1 mm, RAL 9006, with grounding tag
8	1	Base plate, St, 1 mm, RAL 9006, with grounding tag
9	1	Rear panel, St, 1 mm, RAL 9006, with grounding tag
10	4	Case foot with anti-slip protection, PC, black, UL 94 V-0
11	1	Assembly kit

Items 1, 2, 3, 4, 5, 6, and 9 fitted.

Cases

compacPRO—Cases 2, 3 and 4 U

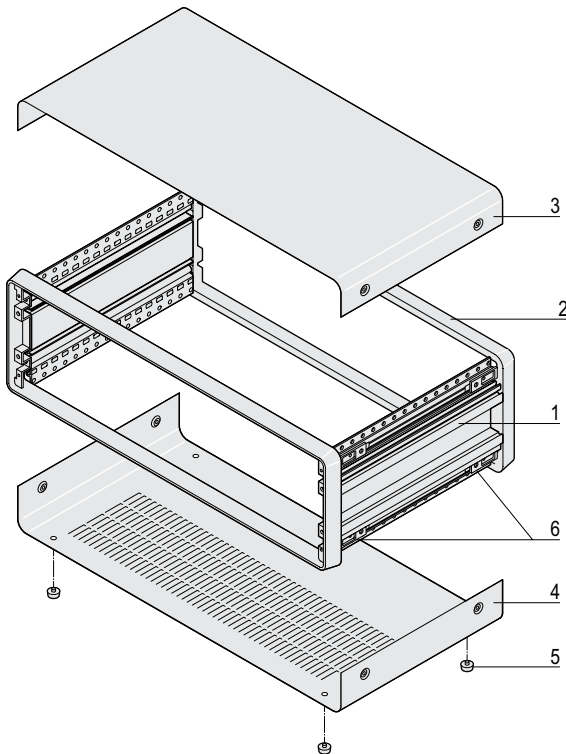
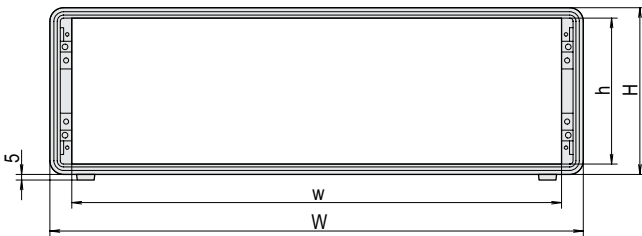
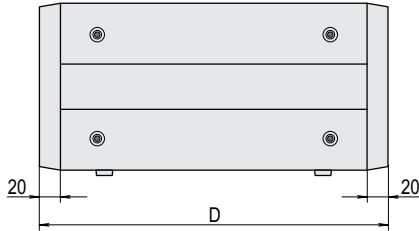

- Desktop enclosures, prefitted, for individual assembly
- For backplane mounting with insulation strips
- Ventilation slots in base plate

Standard Product

Height (U)	Usable width (HP)	Width W (mm)	Width w (mm)	Height H (mm)	Height h (mm)	Depth D (mm)	Part no.
2	42	257	219	102.6	84.4	271	14575-023
2	42	257	219	102.6	84.4	331	14575-025
2	42	257	219	102.6	84.4	391	14575-027
2	84	471	432	102.6	84.4	271	14575-063
2	84	471	432	102.6	84.4	331	14575-065
2	84	471	432	102.6	84.4	391	14575-067
3	28	186	148	147.1	129.3	271	14575-103
3	28	186	148	147.1	129.3	331	14575-105
3	42	257	219	147.1	129.3	271	14575-123
3	42	257	219	147.1	129.3	331	14575-125
3	42	257	219	147.1	129.3	391	14575-127
3	63	364	326	147.1	129.3	271	14575-143
3	63	364	326	147.1	129.3	331	14575-145
3	63	364	326	147.1	129.3	391	14575-147
3	84	471	432	147.1	129.3	271	14575-163
3	84	471	432	147.1	129.3	331	14575-165
3	84	471	432	147.1	129.3	391	14575-167
3	84	471	432	147.1	129.3	451	14575-169
3	84	471	432	147.1	129.3	511	14575-171
4	42	257	219	191.6	173.8	271	14575-223
4	42	257	219	191.6	173.8	331	14575-225
4	63	364	326	191.6	173.8	271	14575-243
4	63	364	326	191.6	173.8	331	14575-245
4	63	364	326	191.6	173.8	391	14575-247
4	84	471	432	191.6	173.8	331	14575-265
4	84	471	432	191.6	173.8	391	14575-267
4	84	471	432	191.6	173.8	451	14575-269
4	84	471	432	191.6	173.8	511	14575-271

Accessories

Grounding kit	24575-801
Cu wire, 1.5 mm ² , PVC sleeve, green/yellow, 1 kit	

Includes (kit, item 1 and 2 assembled)

Item	Qty.	Description
1	2	Side panel, Al extrusion, powder-coated, RAL 7016
2	2	Frame, Al die-cast, powder-coated, RAL 7016
3	1	Cover plate, Al, 1.5 mm, powder-coated, RAL 9006, with grounding connection
4	1	Base plate with 4 rows of ventilation slots, Al, 1.5 mm, powder-coated RAL 9006, with grounding connection
5	4	Case foot with anti-slip protection, PC, black
6	8	Cover plate fixing adapter, prefitted
7	1	Assembly kit, additionally allows mounting of a full-width front panel, two cover brackets or a rear panel

Cases

compacPRO—Accessories

	Description	Part no.
	Front panel Al, 3 mm, height 2 U, width 42 HP, 1 piece	30823-209
	Front panel Al, 3 mm, height 2 U, width 84 HP, 1 piece	30823-215
	Front panel Al, 3 mm, height 3 U, width 28 HP, 1 piece	30823-254
	Front panel Al, 3 mm, height 3 U, width 42 HP, 1 piece	30823-257
	Front panel Al, 3 mm, height 3 U, width 63 HP, 1 piece	30823-224
	Front panel Al, 3 mm, height 3 U, width 84 HP, 1 piece	30823-260
	Front panel Al, 3 mm, height 4 U, width 42 HP, 1 piece	30823-269
	Front panel Al, 3 mm, height 4 U, width 63 HP, 1 piece	30823-227
	Front panel Al, 3 mm, height 4 U, width 84 HP, 1 piece	30823-272
	Front panel Al, 3 mm, height 6 U, width 63 HP, 1 piece	30823-230
Front panel Al, 3 mm, height 6 U, width 84 HP, 1 piece	30823-284	
	Rear panel Al, 2 mm, height 2 U, width 42 HP, 1 piece	30823-015
	Rear panel Al, 2.5 mm, height 2 U, width 84 HP, 1 piece	30823-512
	Rear panel Al, 2 mm, height 3 U, width 28 HP, 1 piece	30823-021
	Rear panel Al, 2 mm, height 3 U, width 42 HP, 1 piece	30823-024
	Rear panel Al, 2 mm, height 3 U, width 63 HP, 1 piece	30823-027
	Rear panel Al, 2.5 mm, height 3 U, width 84 HP, 1 piece	30823-515
	Rear panel Al, 2 mm, height 4 U, width 42 HP, 1 piece	30823-033
	Rear panel Al, 2 mm, height 4 U, width 63 HP, 1 piece	30823-036
	Rear panel Al, 2.5 mm, height 4 U, width 84 HP, 1 piece	30823-518
	Rear panel Al, 2 mm, height 6 U, width 63 HP, 1 piece	30823-045
Rear panel Al, 2.5 mm, height 6 U, width 84 HP, 1 piece	30823-521	
	Tip-up carrying handle for case height 2 U, width 42 HP, 1 piece	24575-038
	Tip-up carrying handle for case height 2 U, width 84 HP, 1 piece	24575-078
	Tip-up carrying handle for case height 3, 4 U, width 28 HP, 1 piece	24575-118
	Tip-up carrying handle for case height 3, 4 U, width 42 HP, 1 piece	24575-138
	Tip-up carrying handle for case height 3, 4 U, width 63 HP, 1 piece	24575-158
	Tip-up carrying handle for case height 3, 4 U, width 84 HP, 1 piece	24575-178
	Tip-up foot silver, similar to RAL 9006, 4 pieces	20603-001
	Tip-up foot anthracite similar to RAL 7016, 4 pieces	20603-002
	Filler angle Al extrusion, anodized, 2 U, 1 piece	24575-019
	Filler angle Al extrusion, anodized, 3 U, 1 piece	24575-119
	Filler angle Al extrusion, anodized, 4 U, 1 piece	24575-219
	Filler angle Al extrusion, anodized, 5 U, 1 piece	24575-419
	Front horizontal rail 42 HP, 1 piece (Qty. 10)	34560-242
	Rear horizontal rail 42 HP, 1 piece (Qty. 10)	34560-542
	Front horizontal rail 84 HP, 1 piece (Qty. 10)	34560-284
	Rear horizontal rail 84 HP, 1 piece (Qty. 10)	34560-584
	Threaded strip , 28 HP, 146.82 mm, 1 piece	34561-328
	Threaded strip , 42 HP, 217.94 mm, 1 piece	34561-342
	Threaded strip , 63 HP, 324.62 mm, 1 piece	34561-363
	Threaded strip , 84 HP, 431.3 mm, 1 piece	34561-384
	Insulation strip 28 HP, PBT UL 94V-0, gray, Qty. 10 pieces	24560-828
	Insulation strip 42 HP, PBT UL 94V-0, gray, Qty. 10 pieces	24560-842
	Insulation strip 63 HP, PBT UL 94V-0, gray, Qty. 10 pieces	24560-863
	Insulation strip 84 HP, PBT UL 94V-0, gray, Qty. 10 pieces	24560-884

ratiopacPRO—Cases

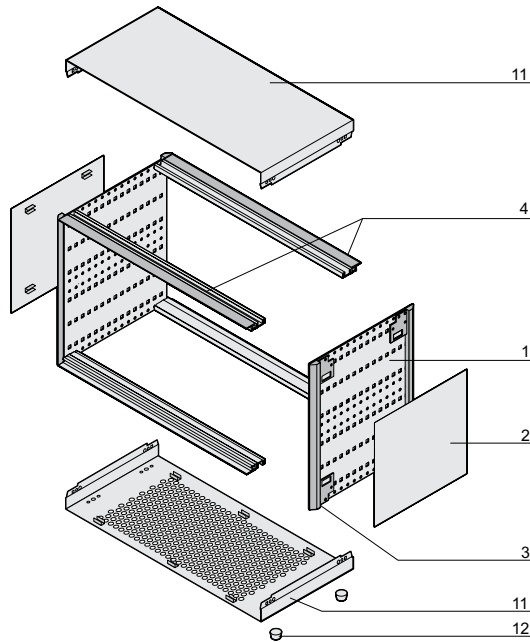

Cases

- Cases for individual expansion or to house 19-in. standard components (e.g. with mounting plate)
- Unshielded (EMC shielding retrofittable)
- Symmetrical design, identical front and rear side
- Available in three versions:
 - with cover strips
 - with front handles
 - with 19-in. mounting bracket
- For board depth 160 mm, 220 mm, 280 mm and 340 mm

Includes (Kit)

Item	Qty.	Description
1	2	Side panel, Al, 2 mm, chromated
2	2	Side plate, Al, 1 mm, visible surface powder-coated, RAL 9006
3	2	Rear trim, Zn die-cast, powder-coated, RAL 7016
3a	2	Cover strip, Zn die-cast, powder-coated, RAL 7016
3b	2	Front handle, Al die-cast, powder-coated, RAL 7016
3c	2	19-in. mounting angle, Al die-cast, powder-coated, RAL 7016
4	4	Horizontal rail, Al, visible surface powder-coated, RAL 7016
11	2	Top cover and base plate, Al, 1 mm, internal surface conductive, visible surface powder-coated, RAL 9006, with grounding connections, base plate with honeycomb grid ventilation
12	4	Case foot with anti-slip protection, UL 94V-0, PC black
13	1	Assembly kit

3a, 3b or 3c depending on selection

Standard Product

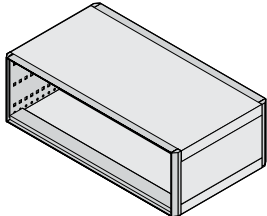
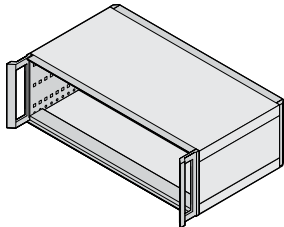
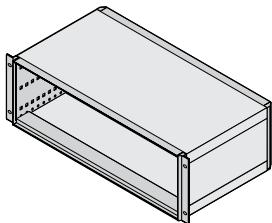
	Width w (HP)	Depth D (mm)	Case height H			
			2 U Part no.	3 U Part no.	4 U Part no.	6 U Part no.
3a: with cover strips 	28	255.5	24572-500	24571-002	24571-050	24571-098
	42	255.5	24572-510	24571-014	24571-062	24571-110
	42	315.5	24572-513	24571-017	24571-065	24571-113
	63	255.5	24572-520	24571-026	24571-074	24571-122
	63	375.5	24572-524	24571-030	24571-078	24571-126
	84	315.5	24572-533	24571-041	24571-089	24571-137
	84	495.5	24572-536	24571-044	24571-092	24571-140
3b: with front handles 	28	255.5	–	24571-702	24571-750	24571-798
	42	255.5	–	24571-714	24571-762	24571-810
	42	375.5	–	24571-718	24571-766	24571-814
	63	255.5	–	24571-726	24571-774	24571-822
	63	375.5	–	24571-730	24571-778	24571-826
	84	375.5	–	24571-742	24571-790	24571-838
	84	495.5	–	24571-744	24571-792	24571-840
3c: with 19-in. mounting bracket 	84	315.5	24572-573	24571-441	24571-489	24571-537
	84	375.5	24572-574	24571-442	24571-490	24571-538
	84	435.5	24572-575	24571-443	24571-491	24571-539

ratiopacPRO-air—Cases

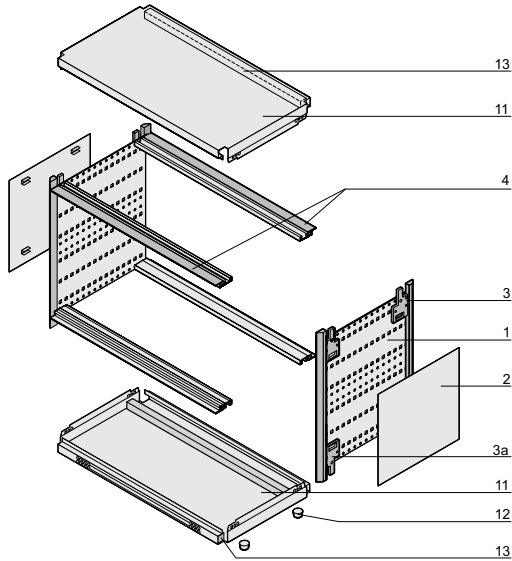
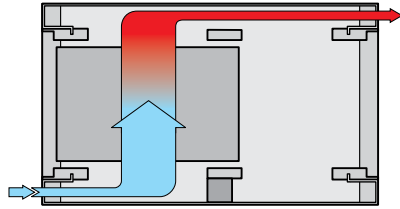

Cases

- Cases for individual expansion or to house 19-in. standard components (e.g., with mounting plate)
- Unshielded (EMC shielding retrofittable)
- Symmetrical design, identical front and rear side
- Available in three versions:
 - with cover strips
 - with front handles
 - with 19-in. mounting bracket
- For board depth 160 mm, 220 mm, 280 mm and 340 mm

Includes (kit)

Item	Qty.	Description
1	2	Side panel, Al, 2 mm, chromated
2	2	Side plate, Al, 1 mm, visible surface powder-coated, RAL 9006
3	2	Rear trim, Zn die-cast, powder-coated, RAL 7016
3a	2	Cover strip, Zn die-cast, powder-coated, RAL 7016
3b	2	Front handle, Al die-cast, powder-coated, RAL 7016
3c	2	19-in. mounting angle, Al die-cast, powder-coated, RAL 7016
4	4	Horizontal rail, Al, visible surface powder-coated, RAL 7016
11	2	Top cover and base plate, Al, 1 mm, internal surface conductive, visible surface powder-coated, RAL 9006, with grounding connections, base plate with honeycomb grid ventilation
12	4	Case foot with anti-slip protection, UL 94 V-0, PC black
13	1	Assembly kit

Standard Product

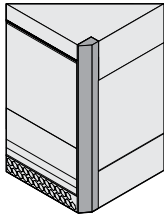
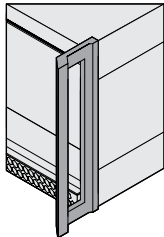
		Case height H			
		4 (U)	5 (U)	7 (U)	
		PCB height h			
		3 U	4 U (3+1 U)	6 U	
		<div style="border: 1px solid black; width: 100px; height: 100px; margin: 0 auto; display: flex; align-items: center; justify-content: center;"> <div style="border: 1px solid black; width: 60px; height: 60px; margin: 0 auto; display: flex; align-items: center; justify-content: center;"> <div style="border: 1px solid black; width: 40px; height: 40px; margin: 0 auto; display: flex; align-items: center; justify-content: center;"> <p>3</p> </div> </div> </div>			
		Part no.	Part no.	Part no.	
3a: with cover strips 	Width w (HP)	28	24571-146	24571-194	24571-242
	Depth D (mm)	42	24571-158	24571-206	24571-254
		42	24571-161	24571-209	24571-257
		63	24571-170	24571-218	24571-266
		63	24571-174	24571-222	24571-270
		84	24571-185	24571-233	24571-281
		84	24571-186	24571-234	24571-282
		84	24571-187	24571-235	24571-283
3b: with front handles 	Width w (HP)	28	24571-846	24571-894	24571-942
	Depth D (mm)	42	24571-858	24571-906	24571-954
		42	24571-862	24571-910	24571-958
		42	24571-863	24571-911	24571-959
		63	24571-873	24571-921	24571-969
		63	24571-875	24571-923	24571-971
		84	24571-882	24571-930	24571-978
		84	24571-886	24571-934	24571-982
	84	24571-888	24571-936	24571-984	

also available with 19-in. mounting bracket

Cases

ratiopacPRO, ratiopacPRO-air—Accessories



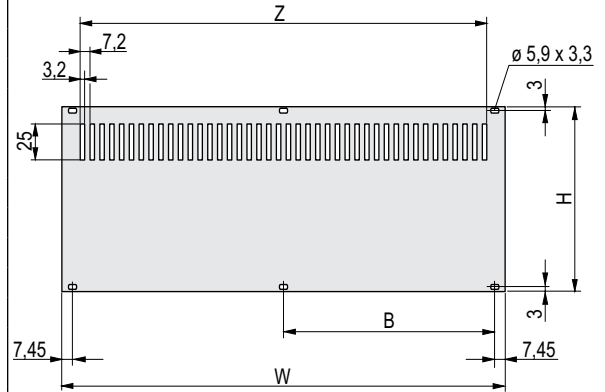
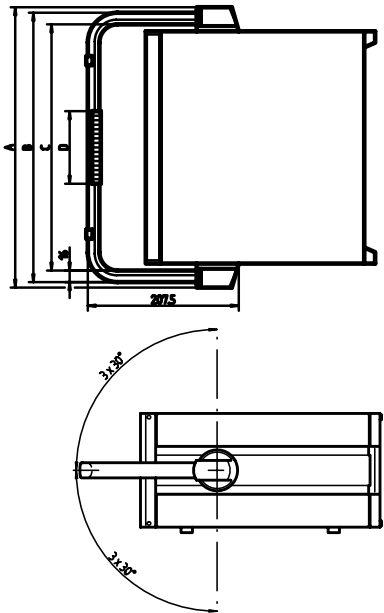
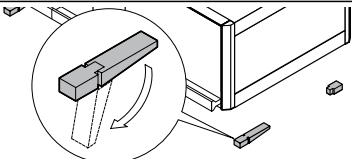

Standard Product

	Description	Part no.
	Rear panels with vent slots Al, 2.5 mm, 2 U, 28 HP, 1 piece	30849-007
	Rear panels with vent slots Al, 2.5 mm, 2 U, 42 HP, 1 piece	30849-014
	Rear panels with vent slots Al, 2.5 mm, 2 U, 63 HP, 1 piece	30849-015
	Rear panels with vent slots Al, 2.5 mm, 2 U, 84 HP, 1 piece	30849-016
	Rear panels with vent slots Al, 2.5 mm, 3 U, 28 HP, 1 piece	30849-008
	Rear panels with vent slots Al, 2.5 mm, 3 U, 42 HP, 1 piece	30849-021
	Rear panels with vent slots Al, 2.5 mm, 3 U, 63 HP, 1 piece	30849-022
	Rear panels with vent slots Al, 2.5 mm, 3 U, 84 HP, 1 piece	30849-023
	Rear panels with vent slots Al, 2.5 mm, 4 U, 28 HP, 1 piece	30849-009
	Rear panels with vent slots Al, 2.5 mm, 4 U, 42 HP, 1 piece	30849-028
	Rear panels with vent slots Al, 2.5 mm, 4 U, 63 HP, 1 piece	30849-029
	Rear panels with vent slots Al, 2.5 mm, 4 U, 84 HP, 1 piece	30849-030
	Rear panels with vent slots Al, 2.5 mm, 6 U, 28 HP, 1 piece	30849-010
	Rear panels with vent slots Al, 2.5 mm, 6 U, 42 HP, 1 piece	30849-035
	Rear panels with vent slots Al, 2.5 mm, 6 U, 63 HP, 1 piece	30849-036
	Rear panels with vent slots Al, 2.5 mm, 6 U, 84 HP, 1 piece	30849-037
	Tip-up carrying handles for 42 HP width (3, 4 and 5 U), 1 kit	24571-320
	Tip-up carrying handles for 63 HP width (3, 4 and 5 U), 1 kit	24571-321
	Tip-up carrying handles for 84 HP width (3, 4 and 5 U), 1 kit	24571-322
	Assembly kit for tip-up carrying handle for 3 U PRO and 4 U PRO-air case height, case depth 255 mm	24571-352
	Assembly kit for tip-up carrying handle for 3 U PRO and 4 U PRO-air case height, case depth 315 mm	24571-353
	Assembly kit for tip-up carrying handle for 3 U PRO and 4 U PRO-air case height, case depth 375 mm	24571-354
	Assembly kit for tip-up carrying handle for 3 U PRO and 4 U PRO-air case height, case depth 435 mm	24571-355
	Assembly kit for tip-up carrying handle for 3 U PRO and 4 U PRO-air case height, case depth 495 mm	24571-356
	Assembly kit for tip-up carrying handle for 4 U PRO and 5 U PRO-air case height, case depth 255 mm	24571-359
	Assembly kit for tip-up carrying handle for 4 U PRO and 5 U PRO-air case height, case depth 315 mm	24571-360
Assembly kit for tip-up carrying handle for 4 U PRO and 5 U PRO-air case height, case depth 375 mm	24571-361	
Assembly kit for tip-up carrying handle for 4 U PRO and 5 U PRO-air case height, case depth 435 mm	24571-362	
Assembly kit for tip-up carrying handle for 4 U PRO and 5 U PRO-air case height, case depth 495 mm	24571-363	
	Tip-up foot silver, similar to RAL 9006, 4 pieces	20603-001
	Tip-up foot anthracite similar to RAL 7016, 4 pieces	20603-002

Cases

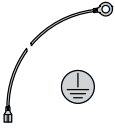
ratiopacPRO, ratiopacPRO-air—Accessories

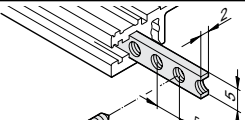
Standard Product

	Description	Part no.
	Grounding kit Cu wire, 1.5 mm ² , PVC sleeve, green/yellow, 1 kit, 1 piece	24571-380
	Front horizontal rail 42 HP, 1 piece (Qty. 10)	34560-242
	Rear horizontal rail 42 HP, 1 piece (Qty. 10)	34560-542
	Front horizontal rail 84 HP, 1 piece (Qty. 10)	34560-284
	Rear horizontal rail 84 HP, 1 piece (Qty. 10)	34560-584
	Threaded strip , 28 HP, 146.82 mm, 1 piece	34561-328
	Threaded strip , 42 HP, 217.94 mm, 1 piece	34561-342
	Threaded strip , 63 HP, 324.62 mm, 1 piece	34561-363
	Threaded strip , 84 HP, 431.3 mm, 1 piece	34561-384
	Insulation strip 28 HP, PBT UL 94V-0, gray, Qty. 10 pieces	24560-828
	Insulation strip 42 HP, PBT UL 94V-0, gray, Qty. 10 pieces	24560-842
	Insulation strip 63 HP, PBT UL 94V-0, gray, Qty. 10 pieces	24560-863
	Insulation strip 84 HP, PBT UL 94V-0, gray, Qty. 10 pieces	24560-884

Retainers

Calmark™ and Birtcher™

Calmark and Birtcher design and manufacture rugged printed circuit board retainers, conduction cooled frame assemblies and extractors for use in non-benign and rugged environments.

Product Overview

- Card-Lok™ and Wedge-Lok™ retainers offer the highest locking force available to hold the PC board firmly in place, providing high resistance to shock and vibration while producing maximum thermal transfer for cold wall applications.
- Lok-Tainer™ retainers are typically mounted to a sheet metal chassis, achieving high resistance to shock and vibration and good thermal transfer.

- PCB-Tainer™ and Calmark Retainers feature a spring-action card retention design. They are designed primarily for use in sheet metal applications, provide protection against shock and vibration, and offer excellent grounding characteristics.
- Calmark and Birtcher Extractors are used for safe and easy extraction of printed circuit boards with high-density connectors.
- Conduction Cooled Assemblies provide a direct thermal path for the heat generated from the processors to the cold wall. Conduction Cooled Assemblies are also used to make the module stiffer for improved resistance to shock and vibrations.

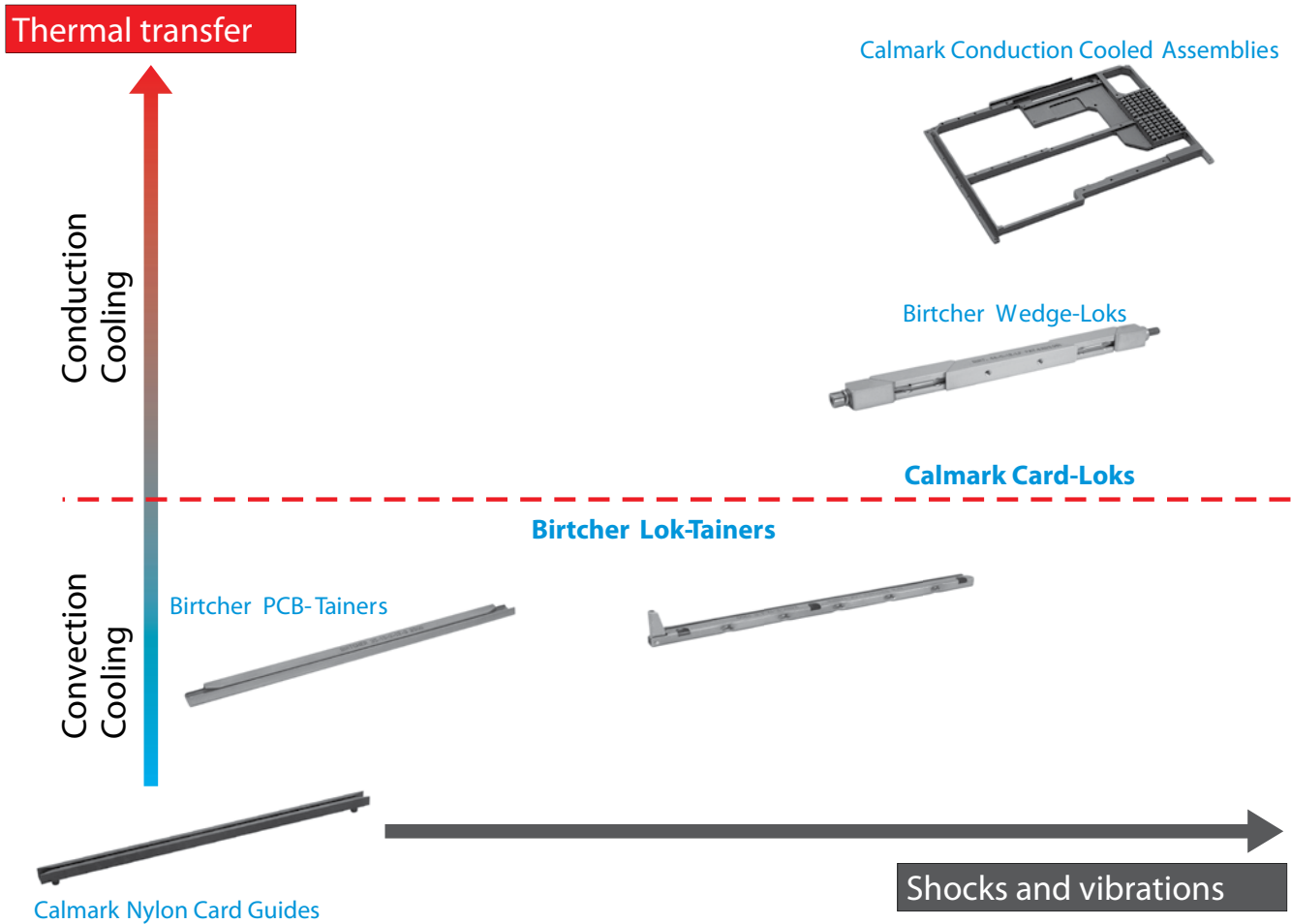

CALMARK™ Products

Card-Lok Features

- Large variety of profiles (width x height) and material finishes available
- Visual indication of locking status
- Self-ejecting Card-Lok
- Custom designs available
 - 7 and 9 or more wedge segments
 - Lengths outside of standard catalog offering

**For more information,
please go to www.calmark.com.**

Series 260—Card-Loks



- Profile: .250 x .270 in.
- Five-segment design for increased clamping force
- Aluminum shaft for increased thermal transfer and lighter weight.

Series LE260—Card-Loks



- Profile: .250 x .270 in.
- Tool free, lever action locking
- Safe and easy module insertion and extraction lever
- Preset and adjustable clamping force
- Five-segment design for increased clamping force
- Aluminum shaft for increased thermal transfer and lighter weight

Series 223 and 224—Torque Limiting Card-Loks



- Profiles: .225 x .260 in. and .210 x .275 in.
- Safe and reliable clamping force without the need for a torque wrench
- Prevents damage to the board or the retainer due to over-tightening
- Enhances "Two-Level Maintenance" capability for your modul

Series 120 Nylon



- Easy and secure snap-in design
- Wide lead-in for easy card entry
- Conductive material available

CALMARK™ Products

Extractors / Inserts

- Lever action for safe and easy extraction and insertion of printed circuit board from connectors
- Available in aluminum and nylon
- Some series offer a positive locking feature
- Up to 8:1 lever ratio



Coding Keys / Inserts

- Method for keying systems with no front panels
- Complies with VITA 1.6 standard
- Six coding configurations per set

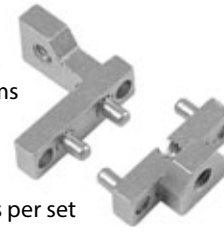

Conduction Cooled Assemblies

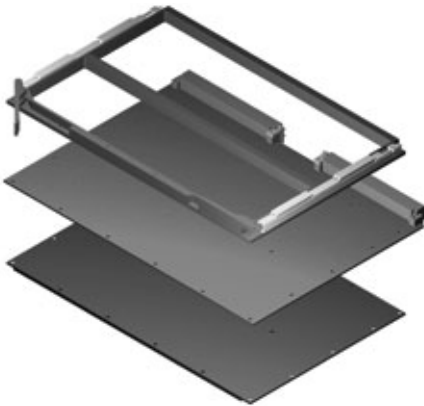

A Conduction Cooled Assembly (CCA) consists of:

- Conduction cooled frame and backing plate
 - To provide a direct thermal path for the heat generated from the processors to the cold wall
 - Makes the module stiffer for improved resistance to shock and vibrations
- Card-Loks or Wedge-Loks provide high clamping force with even pressure distribution for low thermal resistance out to the cold wall
- Extractors provide ample force to disengage board connectors

Our offering:

- Available in 3 U or 6 U (width of frame)
- Various standards:
 - VME/VME64x, compactPCI (IEEE 1101.2, VITA 30.1)
 - VPX (VITA 48.2)
 - μ TCA (PICMG MTCA.3)
 - PMC (VITA 20)
 - Proprietary
- Customization of the frame to match the board and envelope hot components; design types:
 - Basic frames
 - Customized frames
 - Engineered frames
 - Clamshells
- Available in black anodize, hard black anodize, chem film, or electroless nickel plating for excellent corrosion resistance

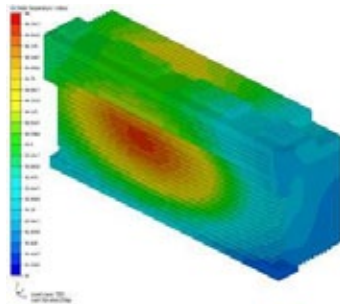

Engineering services:

- Thermal analysis of the module to determine the hotspots and design the conduction cooled frame appropriately
- 3D CAD models available
- Collaborative engineering

Birtcher™ Products

Wedge-Lok Features

- Large variety of profiles (width x height) and material finishes available
- Custom designs available
 - 7 and 9 or more wedge segments
 - Lengths outside of standard catalog offering

For more information,
please go to www.birtcherproducts.com.

Series 48-5—Wedge-Loks



- Profile: .225 x .260 in.
- Screw-actuated wedge action design locks board module assembly in place to provide maximum resistance to shock and vibration
- Wedge action design provides maximum contact between thermal paths on Board Module Assembly and the heat sinking surface

Series 48SL—Wedge-Loks



- Profile: .225 x .260 in.
- Screw-actuated wedge action design locks board module assembly in place to provide maximum resistance to shock and vibration
- Five-segment design for increased clamping force
- Alignment springs return wedge bodies to relaxed position when unclamping and keep wedges in line for tight tolerance situations

Series 120 Nylon



- Easy and secure snap-in design
- Wide lead-in for easy card entry
- Conductive material available

Extractors / Inserts



- Lever action for safe and easy extraction and insertion of printed circuit board from connectors
- Available in aluminum and nylon
- Some series offer a positive locking feature
- Up to 8:1 lever ratio

Series 340 Wedge-Tainer



- For military and commercial applications where harsh environments exist
- For use where retainers are not mounted to PC modules (i.e., SEM-A, B, D, D and E mounted)

Birtcher™ Products

Wedge-Lok / Card-Lok Selection Guide

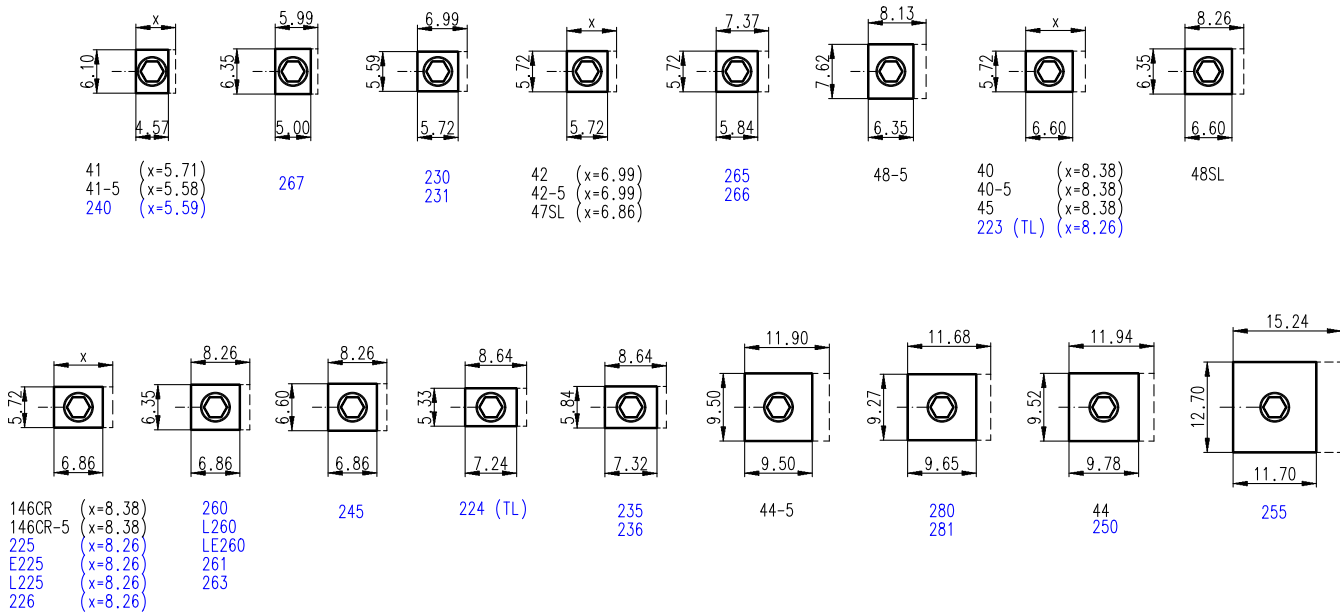

Birtcher Standard Products

Wedge-Loks

Series	Height x Width (in.)	Number of segments* (in)	Length (in.)	Finish	Mounting method	Part number
42 series	.225 x .260	3	3.00	Chemical Film, Clear	2-56 UNC-2B tapped hole	40-6-S
	.225 x .260	3	4.00	Chemical Film, Clear	2-56 UNC-2B tapped hole	40-8-S
	.225 x .260	3	5.00	Chemical Film, Clear	2-56 UNC-2B tapped hole	40-10-S
45 series	.225 x .260	5	3.00	Chemical Film, Clear	2-56 UNC-2B tapped hole	40-5-6
	.225 x .260	5	4.00	Chemical Film, Clear	2-56 UNC-2B tapped hole	40-5-8
	.225 x .260	5	5.00	Chemical Film, Clear	2-56 UNC-2B tapped hole	40-5-10

* The 5 segment version provides a higher clamping force and higher thermal transfer

Lok-Tainers

Series	Actuation type	Material	Length (in.)	Finish	PC board thickness (in.)	Part number
24 series	Lever	Steel	5.00	Nickel plate	.063	24SX-2-10-6-L or -R*
	Lever	Steel	8.00	Nickel plate	.063	24SX-2-16-6-L or -R*
	Lever	Steel	5.00	Nickel plate	.094	24SX-3-10-6-L or -R*
	Lever	Steel	8.00	Nickel plate	.094	24SX-3-16-6-L or -R*

* -R = right hand, -L = left hand

PCB-Tainers

Series	Height (in.)	Material	Length (in.)	Finish	PC board thickness (in.)	Part number
35-1 series	180	Beryllium copper	4.00	Cadmium plating	.063	35-1B-2-8-3
	180	Beryllium copper	6.00	Cadmium plating	.063	35-1B-2-12-3
35-2 series	130	Beryllium copper	4.00	Cadmium plating	.063	35-2B-2-8-3
	130	Beryllium copper	6.00	Cadmium plating	.063	35-2B-2-12-3
35-7 series	125	Beryllium copper	4.00	Cadmium plating	.063	35-7B-2-8-3
	125	Beryllium copper	6.00	Cadmium plating	.063	35-7B-2-12-3

Extractors

Series	Hand action	PC board thickness (in.)	Part number
71 series	Left Hand	.063	71-2-L
	Right hand	.063	71-2-R
	Left Hand	.094	71-3-L
	Right hand	.094	71-3-R

About Pentair Technical Products

Pentair Technical Products, a Pentair global business unit, is the leading provider of worldwide product and service solutions for enclosing, protecting and cooling electrical and electronic systems. Its industry-leading brands—Hoffman®, Schroff® and McLean® Cooling Technology—provide a broad variety of standard, modified and engineered solutions to the commercial, communications, energy, general electronics, industrial, infrastructure, medical and security and defense markets.

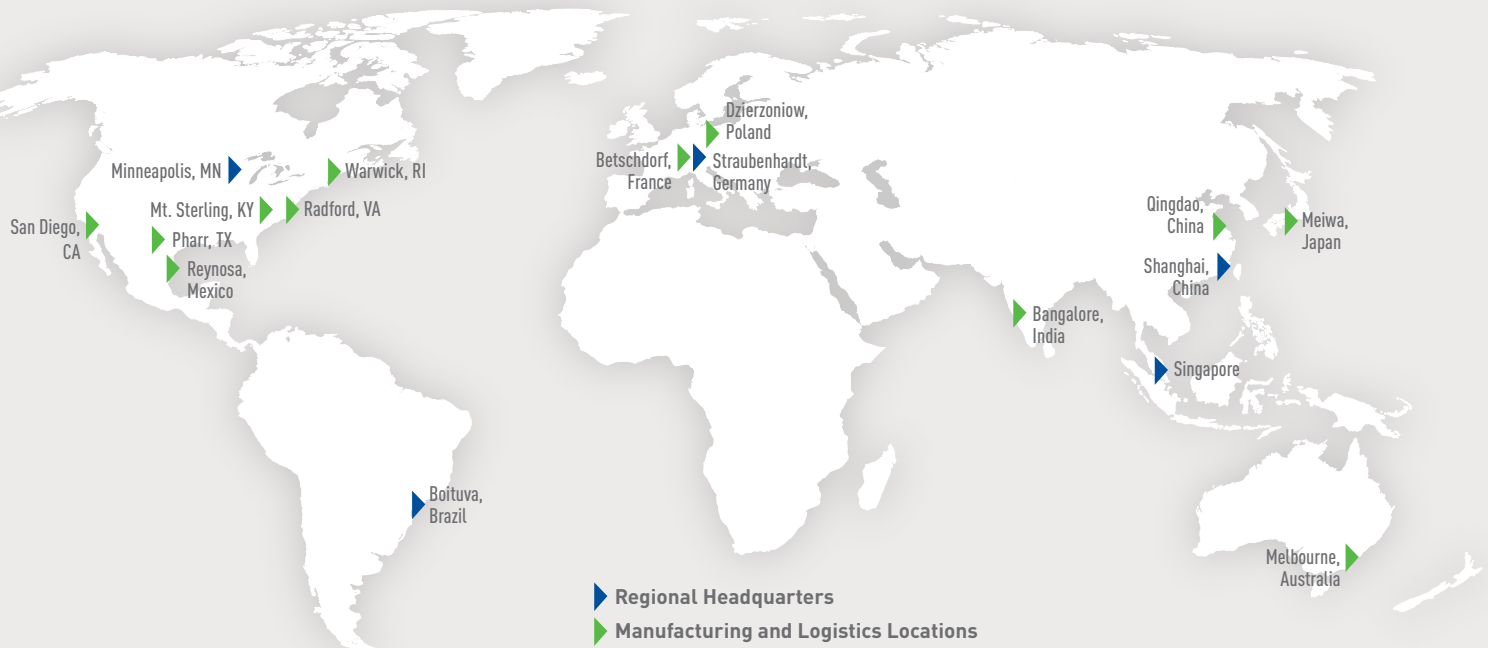

NORTH AMERICA

Pentair Technical Products

2100 Hoffman Way
 Minneapolis, MN 55303-1745
 Tel: +1 (763) 421-2240

170 Commerce Drive
 Warwick, RI 02886
 Tel: +1 (401) 732-3770

7328 Trade Street
 San Diego, CA 92121
 Tel: +1 (858) 740-2400

1120 Rock Road
 Radford, VA 24141
 Tel: +1 (540) 639-4440

Pentair Technical Products

Hoffman Enclosures Inc.
 111 Grangeway Ave., #504
 Scarborough, ON M1H 3E9
 Tel: +1 (416) 289-2770

Pentair Technical Products

Hoffman Enclosures Mexico,
 S. de R.L. de C.V.
 Arquimedes 33 Piso 1
 Colonia Palmas Polanco
 Mexico DF 11560
 Tel: +52 55 5280 1449

SOUTH AMERICA

Pentair Technical Products

Pentair Taunus Electrometalurgica Ltda
 Rua Joao Marcon, 165
 18550-000 – Centro Boituva – SP Brazil
 Tel: +55 15 3363 9100

EUROPE

Pentair Technical Products

Schroff GmbH
 Langenatber Straße 96-100
 75334 Straubenhardt, Germany
 Tel: +49 (0)7082 794-0

Pentair Technical Products

Schroff UK Ltd.
 Unit 4, Grovelands Business Estate
 Boundary Way
 Hemel Hempstead
 Hertfordshire, HP2 7TE
 Tel: +44 (0)1442 240 471

Pentair Technical Products

Schroff SAS
 Z.I. 4, rue du Marais
 Boîte Postale 16
 67660 Betschdorf, France
 Tel: +33 (0)3 88 90 64 90

EUROPE

Pentair Technical Products

Schroff Scandinavia AB
 Flygfältsgatan 11
 P.O. Box 2003
 12821 Skarpnäck, Sweden
 Tel: +46 (0) 8 683 61 00

Pentair Technical Products

Schroff Scandinavia AB
 Peräsimentie 8
 FIN-03100 Nummela
 Finland
 Tel: +358 9 222 68 00

Pentair Technical Products

Schroff S.r.l.
 Via Brughiera 1
 20010 Pregnana Milanese (MI)
 Italy
 Tel: +39 02 932 714-1

Pentair Technical Products

Pentair Poland
 Sp.z.o.o.
 ul. Marynarska 21
 PL-02-674 Warszawa Poland
 Tel: +48 (0) 22 607 06 16

ASIA

Pentair Technical Products

21st Floor of Cloud Nine Plaza
 No. 1118 West Yan'an Road
 Changning District, Shanghai
 P.R. China
 Tel: +86 400 820 1133

Pentair Technical Products

India Pvt. Ltd.
 Unit 1, Factory 2
 (Sai Lakshmi Industrial Campus)
 Kannamangala, Bidarahalli Hobli
 Whitefield – Hoskote Road
 Bangalore – 560 067
 Tel: +91 80 2845 4640

Pentair Technical Products

Hoffman Schroff Pte Ltd.
 18 Boon Lay Way
 TradeHub 21, #04-110/111
 Singapore 609966
 Tel: +65 6795 2213

Pentair Technical Products

Schroff K.K.
 Nisso No.13 Bldg. 4F
 2-5-1 Shinyokohama
 Kohoku-ku yokohama-shi
 Kanagawa 222-0033 Japan
 Tel: +81 (0)45 476 02 81



2100 HOFFMAN WAY, MINNEAPOLIS, MN 55303 WWW.PENTAIRTECHNICALPRODUCTS.COM

©2012 Pentair Technical Products

Printed in the USA CAT-00044 B