

THIS DOCUMENT CONTAINS PROPRIETARY INFORMATION WHICH MAY NOT BE DISCLOSED TO OTHERS, REPRODUCED OR USED WITHOUT AUTHORITY FROM THE PROPRIETOR.

REVISION HISTORY			
REV	DESCRIPTION	INC BY	DATE
A	RELEASE	L FLORES	9-6-07
			APPROVED R GONZALEZ

NOTES: UNLESS OTHERWISE SPECIFIED.

1. APPLICABLE STANDARD/ SPECIFICATIONS:
 ALL PROCESSING/MATERIALS MUST COMPLY WITH 2002/95/EC RoHS
 ASME Y14.5-1994, DIMENSION AND TOLERANCES
 ASME Y14.38, ANSI Y14.38M, ABBREVIATIONS
 MIL-HDBK-454, GUIDELINE 9, WORKMANSHIP
 ES107003 COSMETIC STANDARDS

2. ALL DIMENSIONS SHOWN ARE REFERENCE ONLY AND SHALL NOT BE USED AS INSPECTION CRITERIA.

3 RECOMMENDED COMPONENT WORKING AREA.

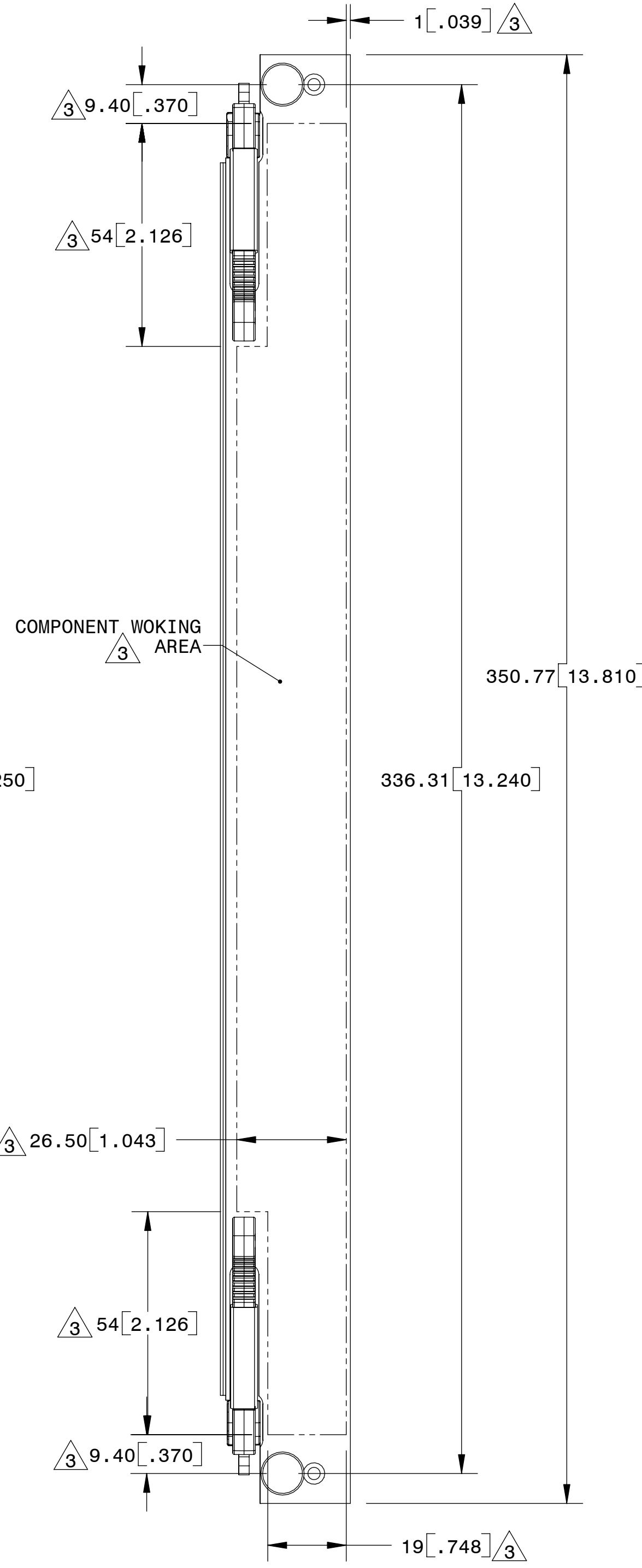
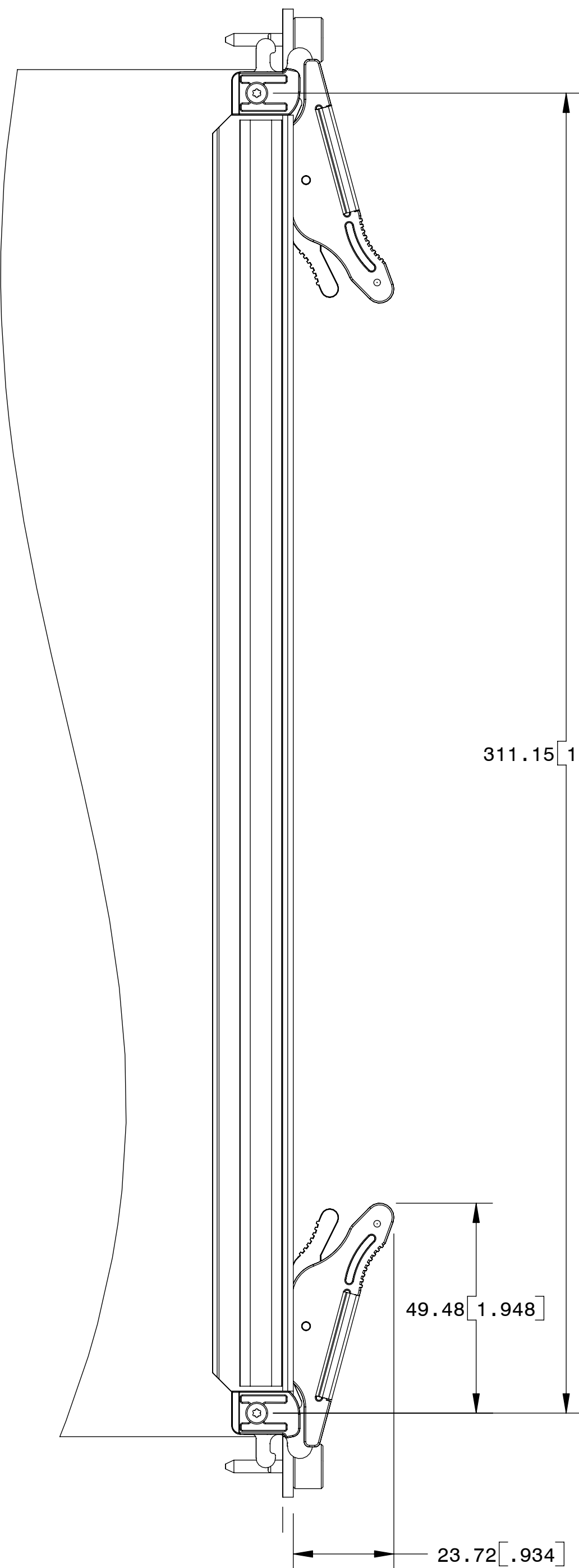

PCB REF.

USER DEFINED, PACKAGE INCLUDES 2 SCREW TYPES

DETAIL B
SCALE 2 : 1
TOP HANDLE
INSTALLATION

REFERENCE
(61594-033)

HANDLE INSTALLATION

USER DEFINED, PACKAGE INCLUDES 2 SCREW TYPES

HANDLE ASSEMBLY PART NUMBERS
10 PCS PART NO. 20817-121
100 PCS PART NO. 20817-126

REFERENCE
(31596-411)

HANDLE ASSEMBLY PART NUMBERS
10 PCS PART NO. 20817-122
100 PCS PART NO. 20817-127

PCB REF.

DETAIL A
SCALE 2 : 1
BOTTOM HANDLE
INSTALLATION

ALL DIMENSIONS mm [INCH]	COSMETIC APPEARANCE MAX CLASS	APPROVALS	DATE
THIRD ANGLE PROJECTION	A B	DESIGNED BY:	
		DRAWN BY:	L FLORES 9-6-07
		CHECKED BY:	R ACOSTA 9-6-07
		RESPONSIBLE ENG:	R GONZALEZ 9-6-07
DESIGN AUTHORITY	MATERIAL	PROJECT/CUSTOMER	FILE NAME
POWAY		ATCA HANDLE	20818-139

MIN CLASS	FINISH	SIZE	CAGE CODE	DWG NO.	REV
		D	61081	20818-139	A
		SCALE	WEIGHT	SHEET	
		1:2	N/A	1 OF 2	

Schroff® ... a brand of		Pentair Electronic Packaging	
TITLE KIT-IEA 2.5 THK PNL-PLUNGER			
SIZE	CAGE CODE	DWG NO.	REV
D	61081	20818-139	A
SCALE	WEIGHT	SHEET	
1:2	N/A	1 OF 2	

10

9

8

7

6

5

4

3

DWG NO. 20818-139

REV A 2 OF 2

1

NOTES: SEE SHEET 1

2.5mm THICK PANEL

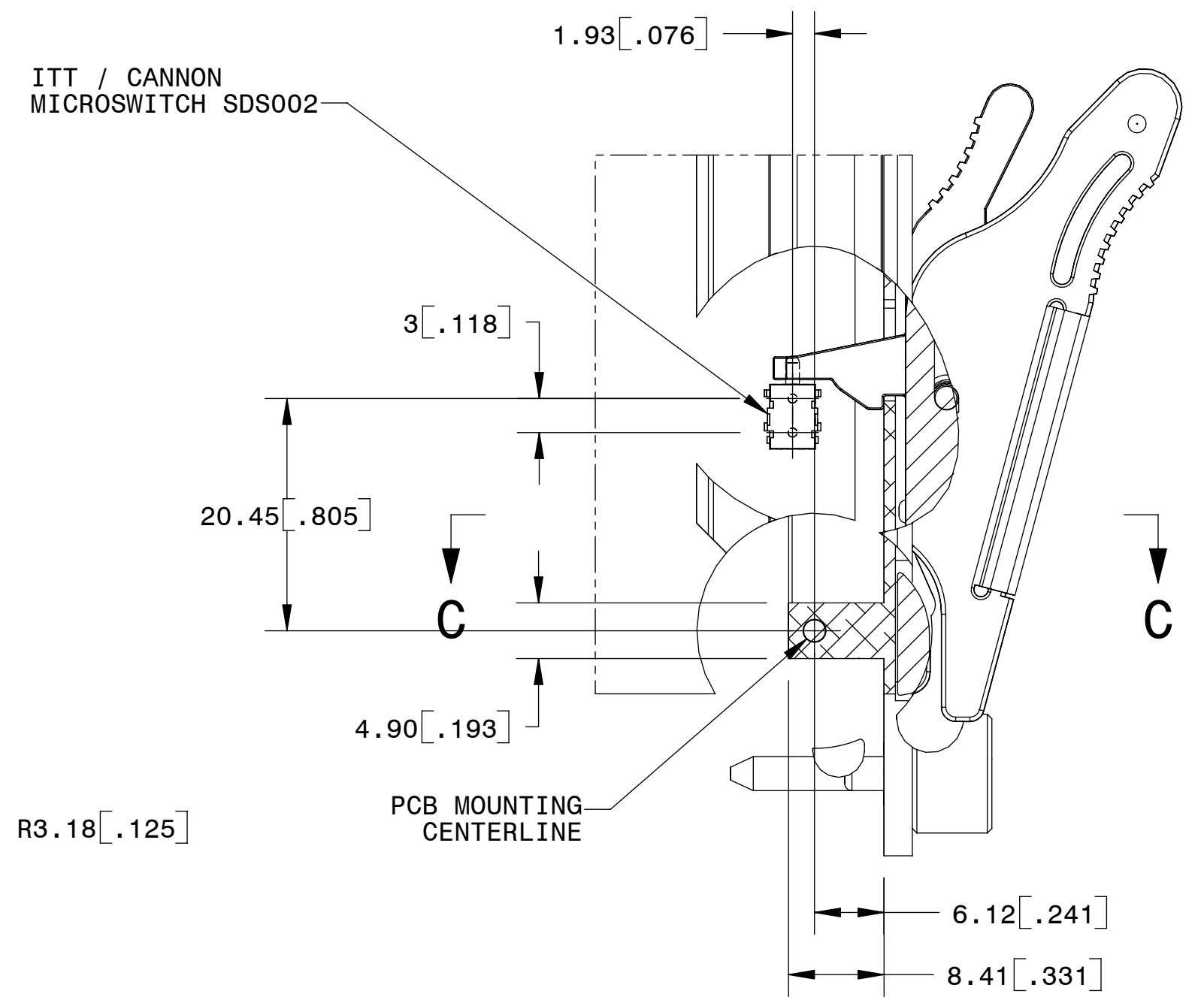
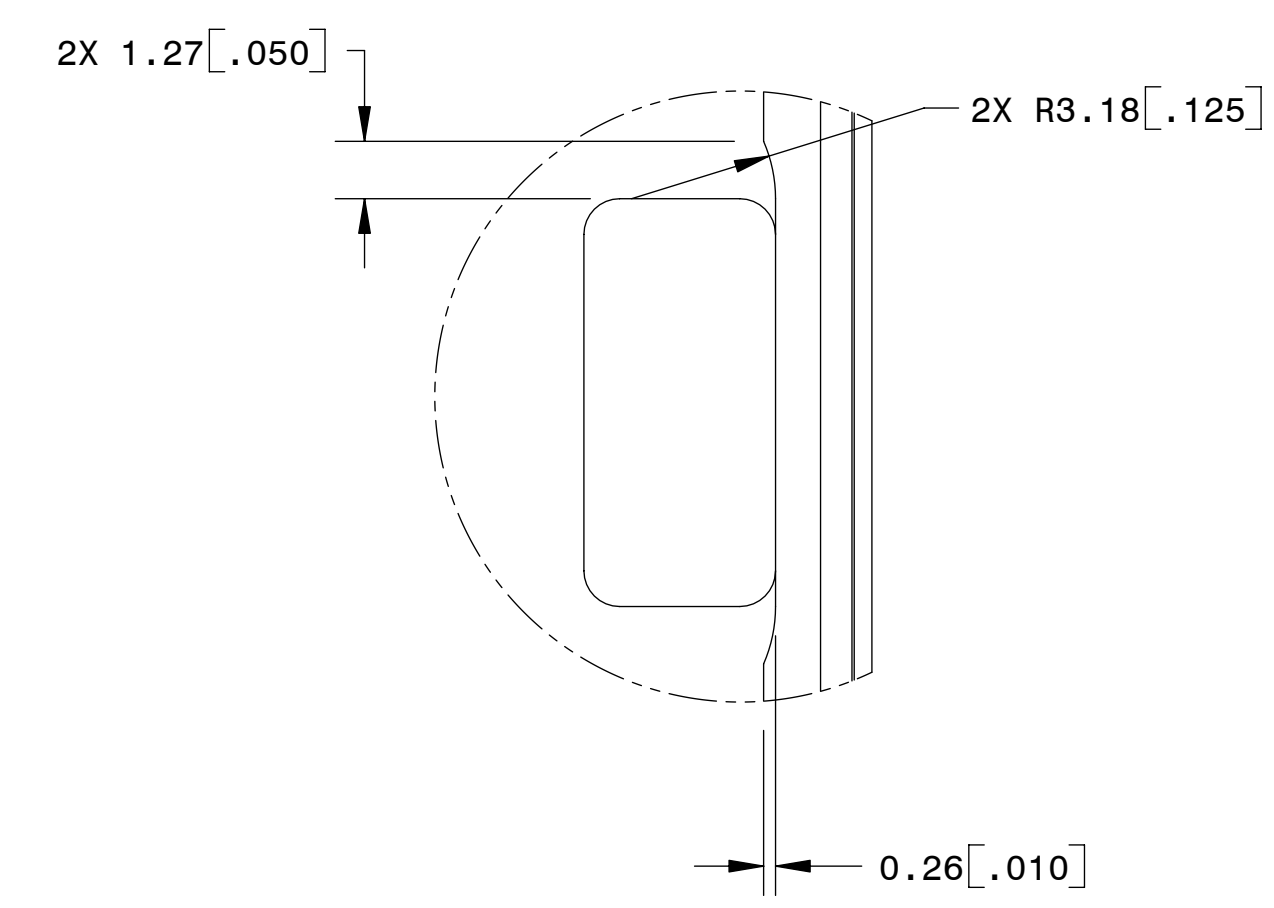
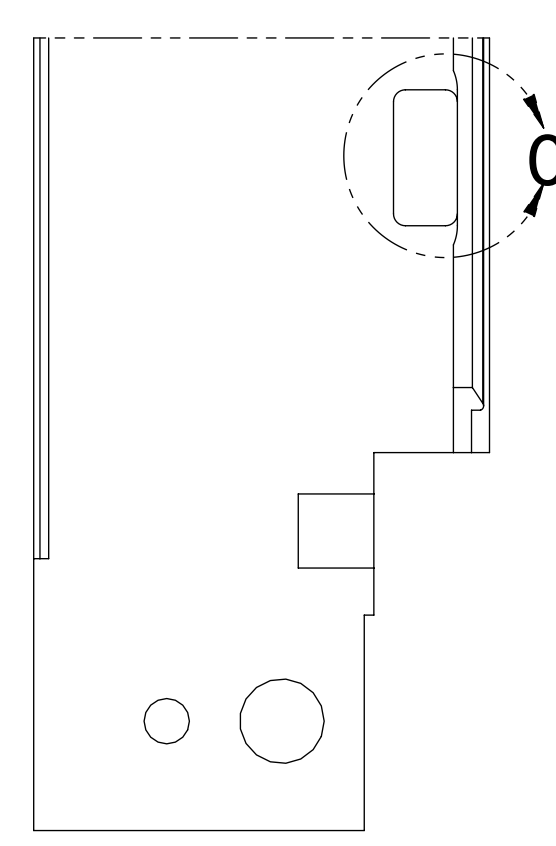
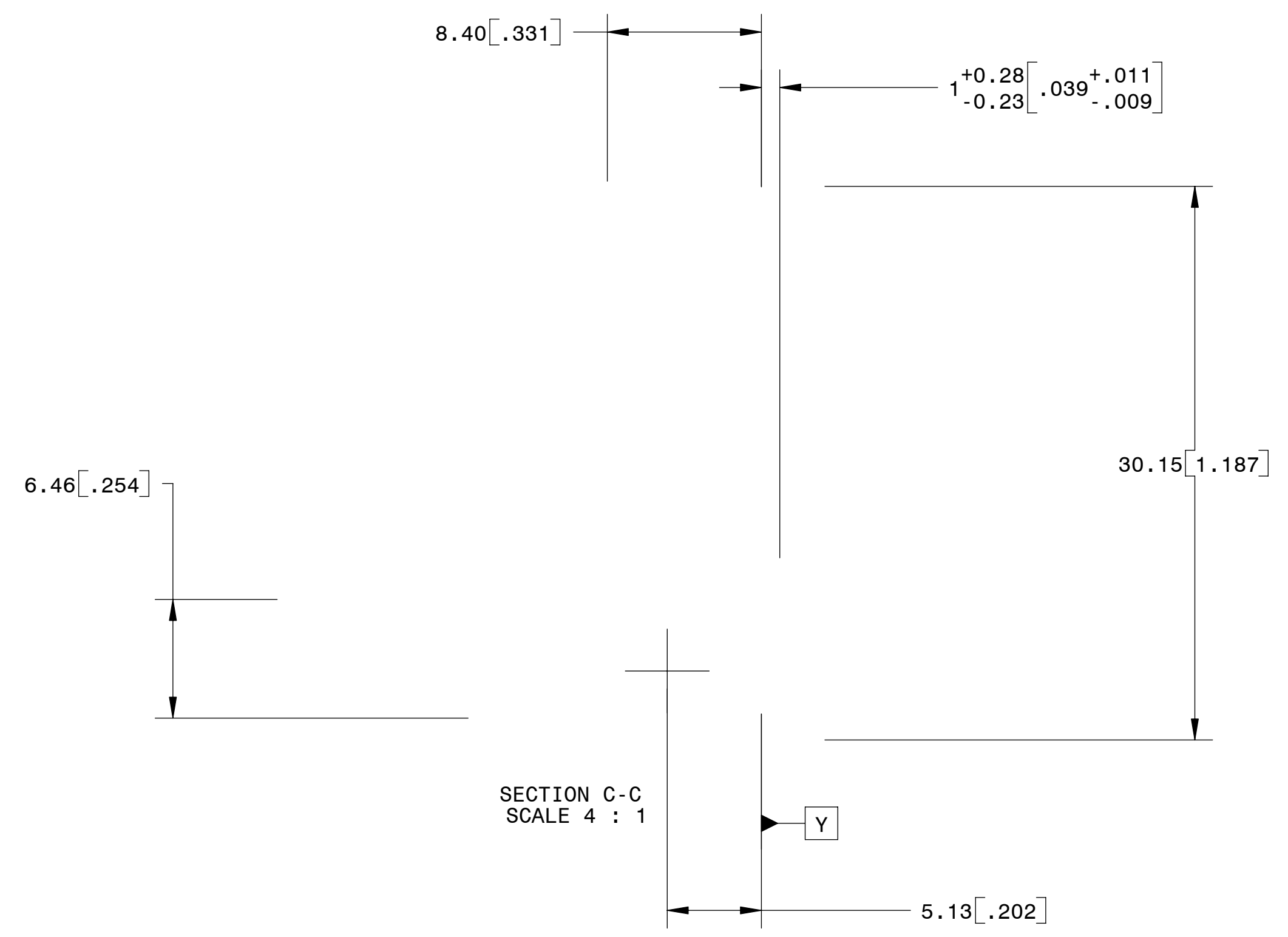

MICROSWITCH LOCATION

