

Dlynx™ Series Evaluation Board Documentation

The Dlynx™ series evaluation board (DLYNX_PICO_MICRO_EVAL) is available in 2 formats:

- Single Footprint- supporting MDT/MVT040, UDT/UVT020, PVX003/006/012, APXW012
- Dual layout of the PicoDlynx™ and the MicroDlynx™ series of modules – supporting PDT003/006/012 and UDT/UVT020

Board comes with an assembled module. The specific combination of module and the board can be ordered through your sales representative. PDT modules can be provided on single footprint boards as well

1. Schematics

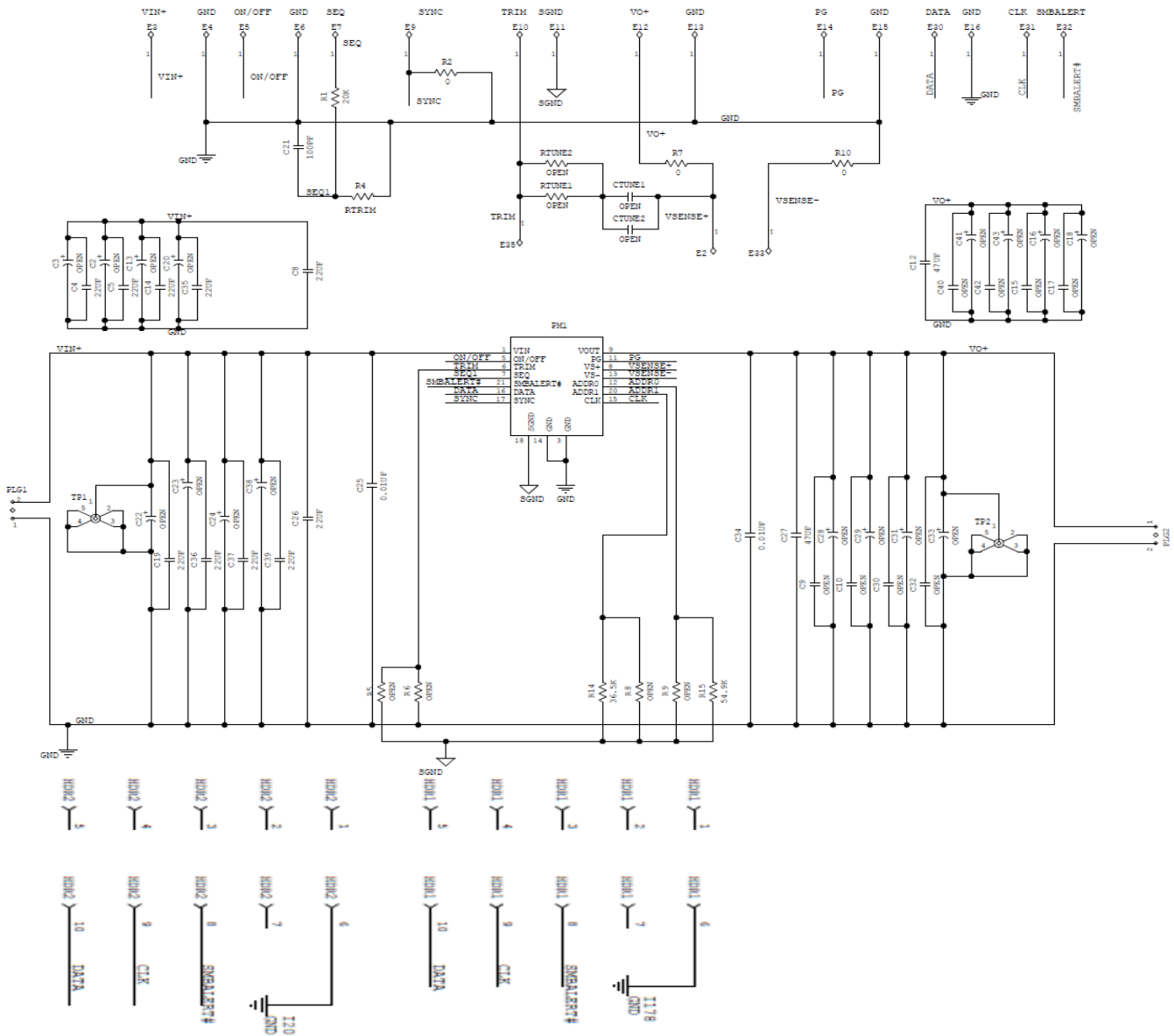

Figure 1 - Schematic of the PicoDlynx™ single footprint evaluation board.

Component values are for reference only; refer to the data sheet for appropriate values and pictures in this document for preinstalled components

Analog and Digital Dlynx™: Non-Isolated DC-DC Power Modules
 3A to 40A Output Current converters

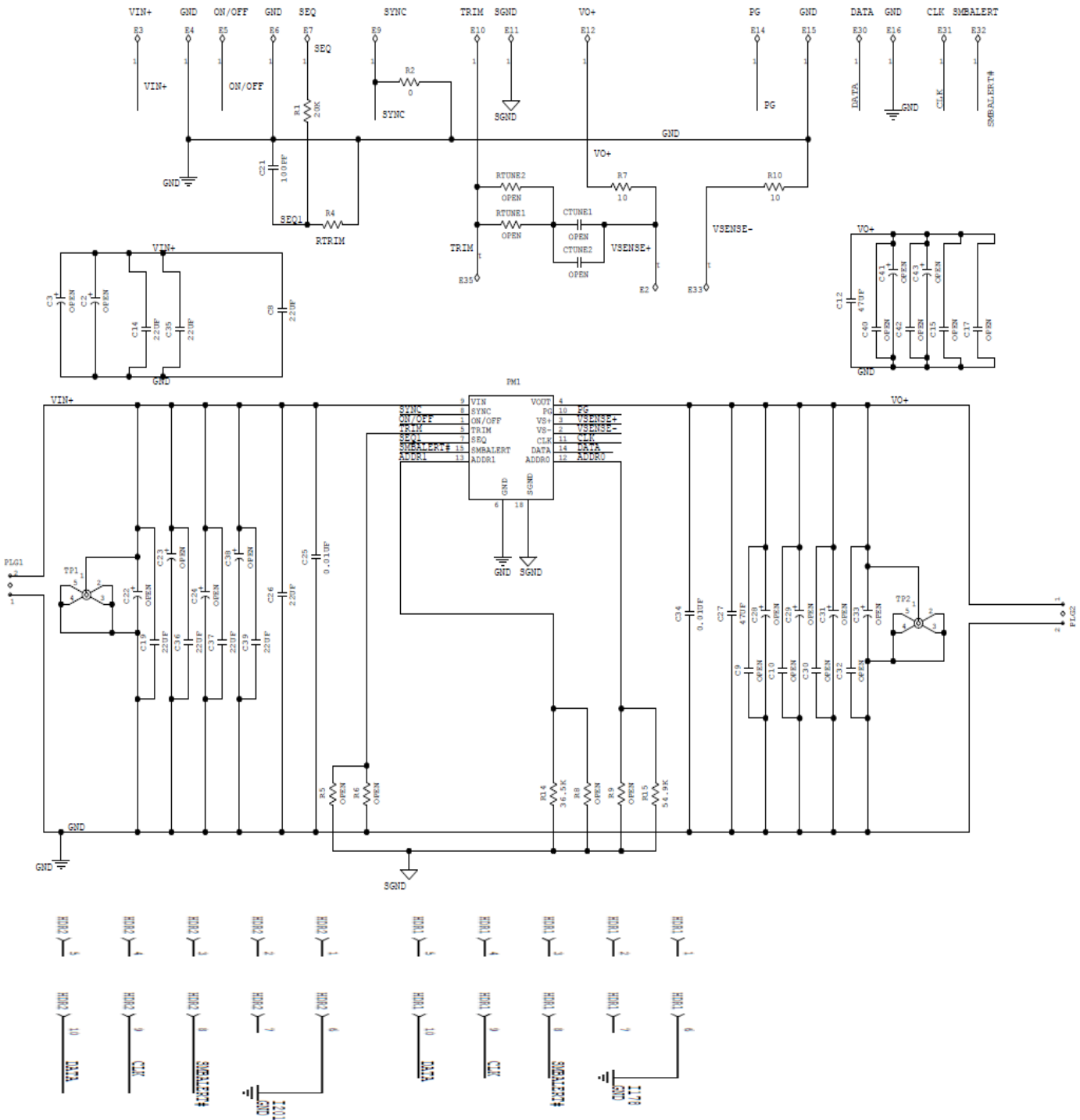

Figure 2 - Schematic of the MicroDlynx™ single footprint evaluation board.

Component values are for reference only; refer to the data sheet for appropriate values and pictures in this document for preinstalled components.

Analog and Digital DLynx™: Non-Isolated DC-DC Power Modules 3A to 40A Output Current converters

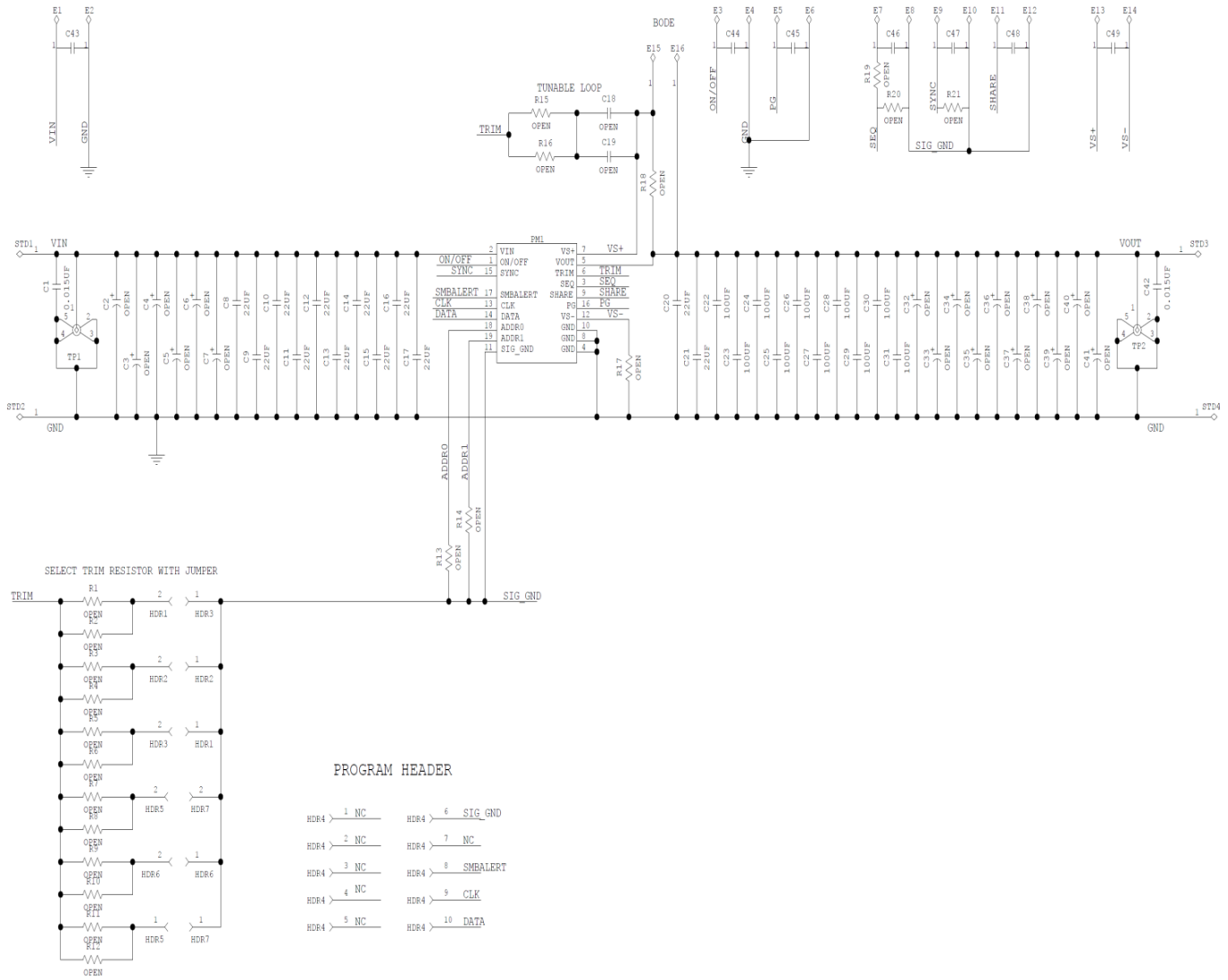

Figure 3 - Schematic of the MegaDLynx™ single footprint evaluation board.

Component values are for reference only; refer to the data sheet for appropriate values and pictures in this document for preinstalled components

Analog and Digital Dlynx™: Non-Isolated DC-DC Power Modules

3A to 40A Output Current converters

Dual layouts on the same board also serve as an example for applications where dual layouts may be desirable, e.g. when the required output current is uncertain and there is an advantage in either adding a higher or lower power capability through a dual layout.

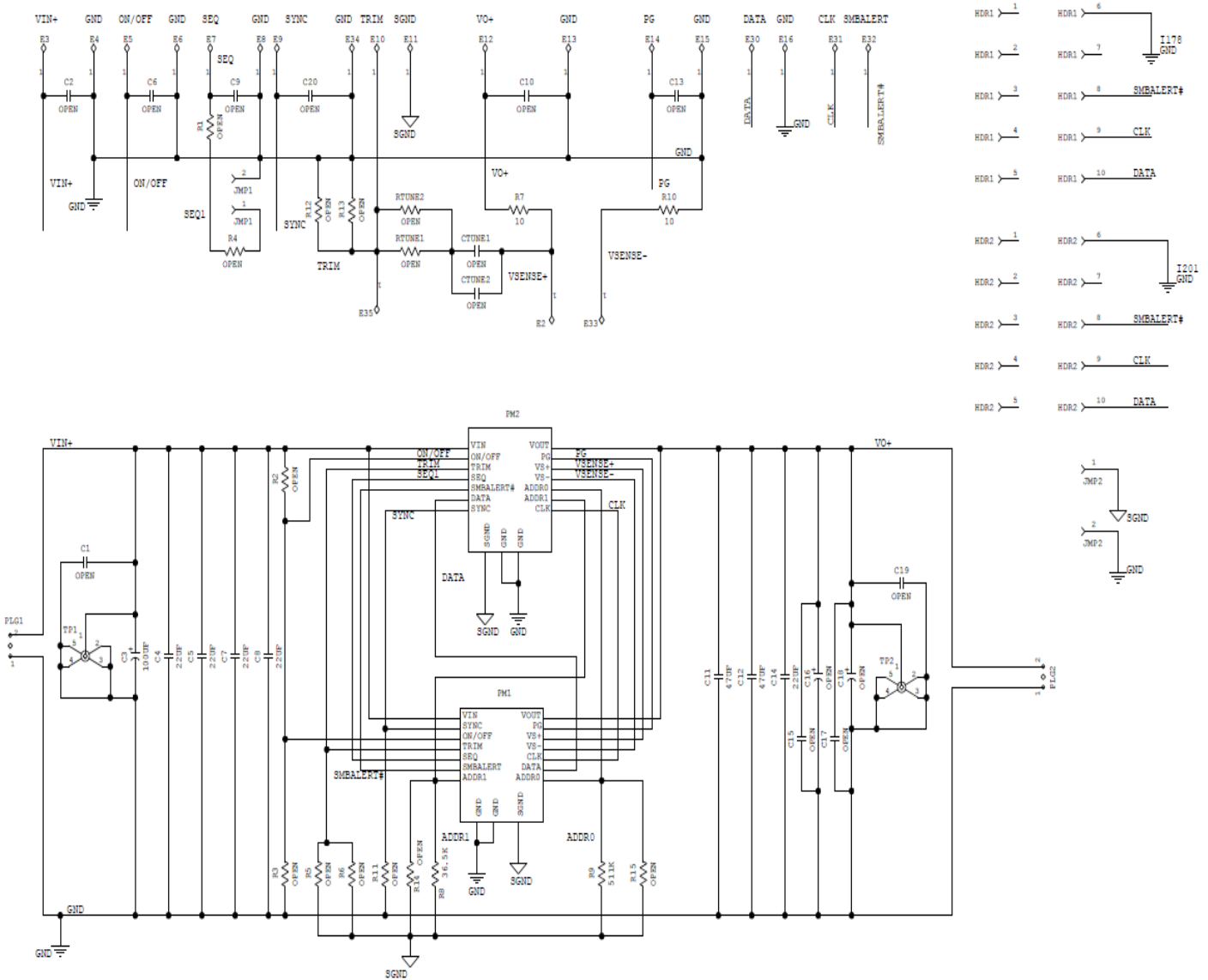

Figure 4. Schematic for the Dual Layout PicoDlynx™/MicroDlynx™ Evaluation board.

Component values are for reference only; refer to the data sheet for appropriate values and pictures in this document for preinstalled components

Analog and Digital DLynx™: Non-Isolated DC-DC Power Modules
 3A to 40A Output Current converters

2. Physical Description

An annotated photograph of the PicoDLynx™, MicroDLynx™ and MegaDLynx™ single footprint evaluation board is shown in Figs. 5, 6 and 7 below. The arrows indicate locations of various components. Pre-Installed components for the PicoDLynx™ - Trim resistor R6, input filtering [C22 (0.047uF,16V), C25(22uF,16V), C26,(22uF,16V), C38(470uF,16V)], Output filtering [C34(0.047uF,16V), C27(22uF,16V)], R_{SENSE} resistors, R7 & R10 = 0 Ohms, R6 =20K and some test points.

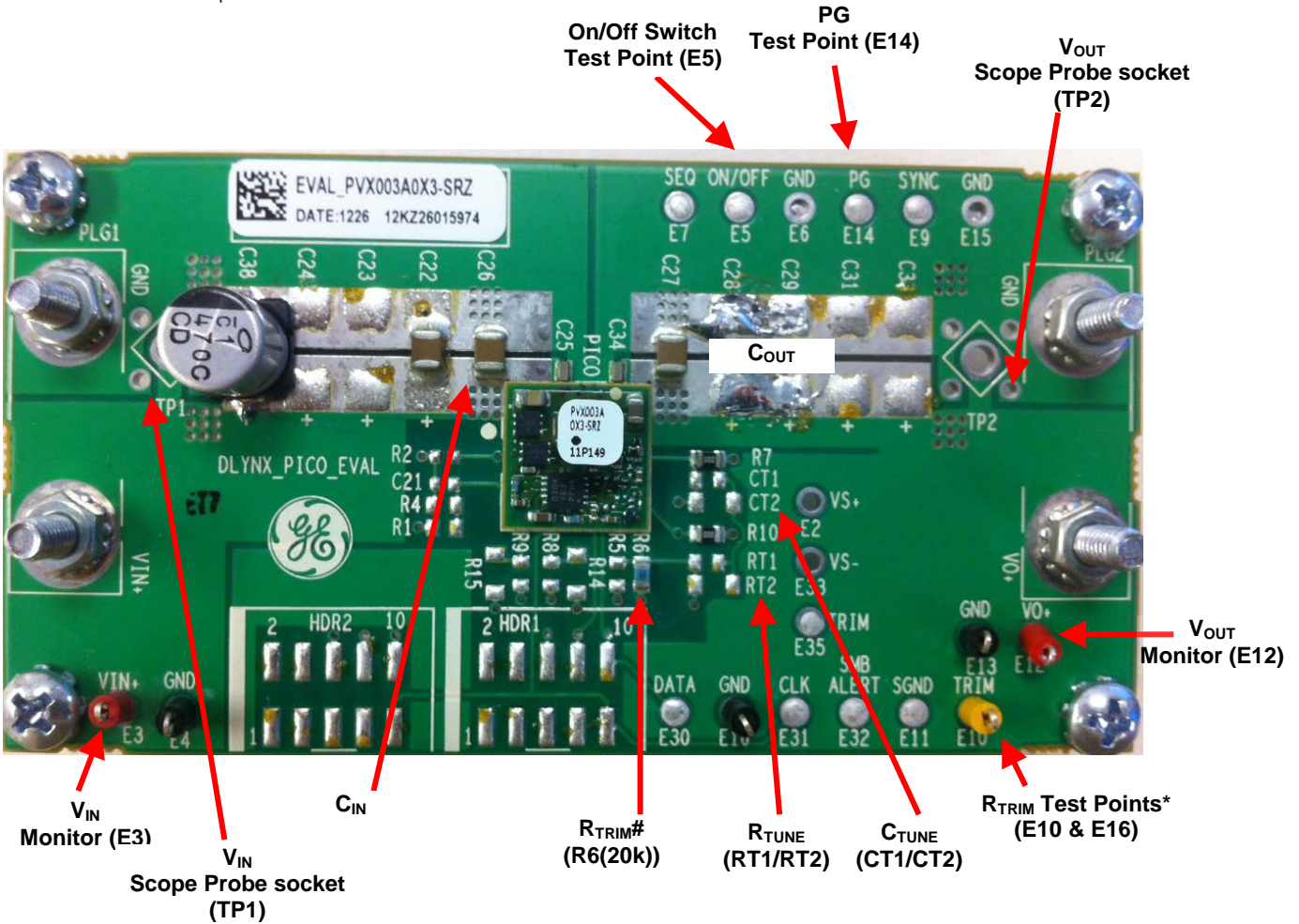

Figure 5. Power and Analog Signal Interface for the PVX003/006/012 Eval Board

Caution! Before applying power, make sure that the externally installed capacitors (input & output) have appropriate voltage and polarity ratings based on the application.

Notes:

Module can be trimmed either by soldering fixed resistor(s) @ R6 or by attaching a potentiometer/resistor between test points E10 and E16.

Analog and Digital Dlynx™: Non-Isolated DC-DC Power Modules

3A to 40A Output Current converters

Pre-Installed components for the MicroDlynx™ - Input filtering [C₂₅ (0.047uF,16V), C₂₂(22uF,16V), C₂₆(22uF,16V), C₃₈(470uF,16V)], Output filtering [C₃₄(0.047uF,16V), C₂₇, C₃₂ (47µF,6.3V)], R_{SENSE} resistors, R₇ & R₁₀ = 0 Ohms, Trim R₅=20K, Address R₁₅=54.9K, R₁₄=36.5K and some test points.

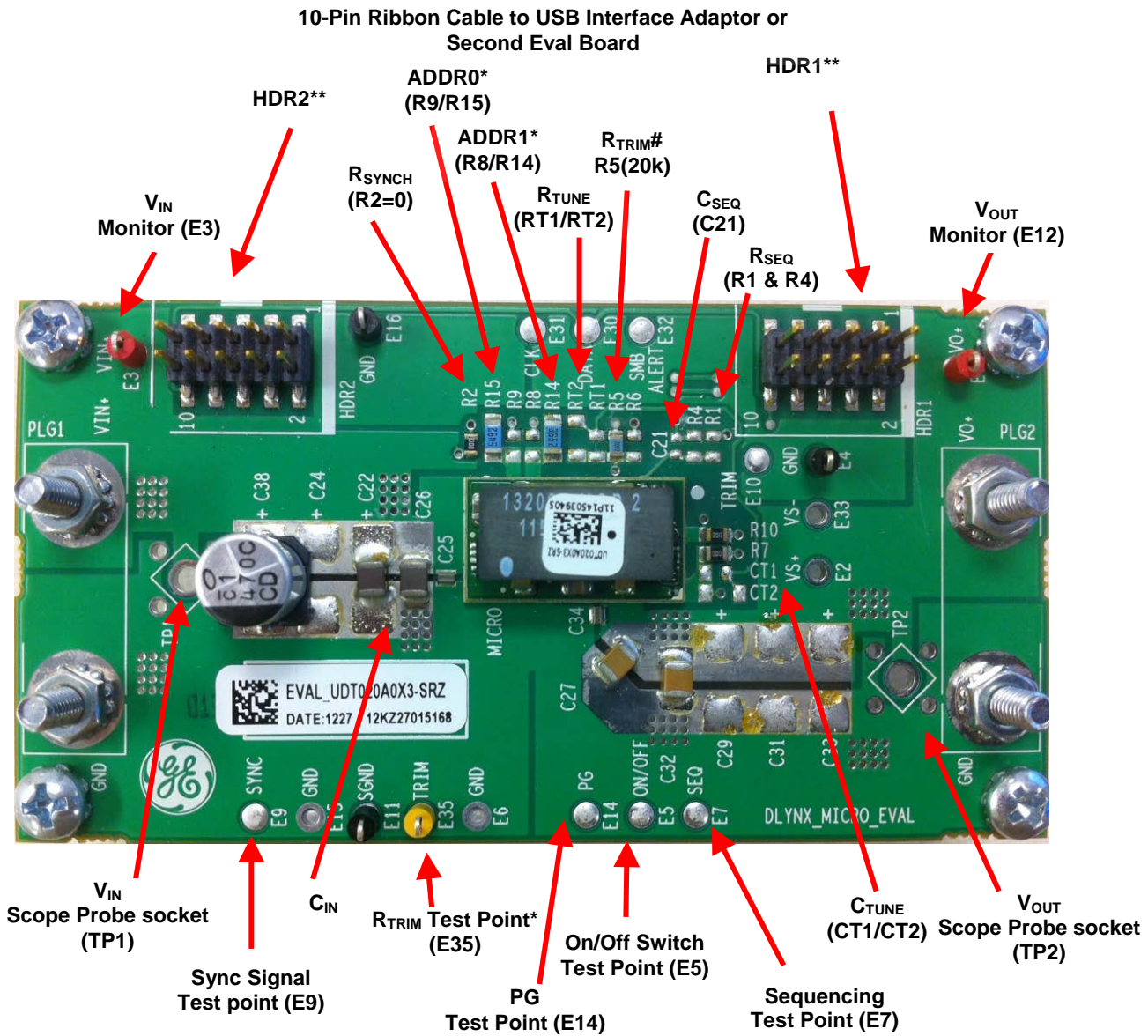

Figure 6. Power and Analog Signal Interface for the UDT/UVT020 Eval Board

Caution! Before applying power, make sure that the externally installed capacitors (input & output) have appropriate voltage and polarity ratings based on the application.

Notes:

Module can be trimmed either by soldering a different fixed resistor(s) @ R₅ or by attaching a potentiometer/resistor between test points E11 and E35.

Analog and Digital Dlynx™: Non-Isolated DC-DC Power Modules

3A to 40A Output Current converters

Pre-Installed components for the MegaDlynx™ - Input filtering [C₁₄,C₅₁ (0.047uF,16V), C₁₃,C₁₅,C₁₆,(22uF,16V), C₅(470uF,16V)], Output filtering [C₂₀,C₂₁,C₅₂,C₅₃(0.047uF,16V),C₂₂,C₂₃,C₂₄,C₂₅ (6x47µF,6.3V)], R_{SENSE} resistors, R₁₇ & R₁₈ = 0 Ohms, Trim R₁=20K, Address R₁₃=54.9K, R₁₄=36.5K and some test points.

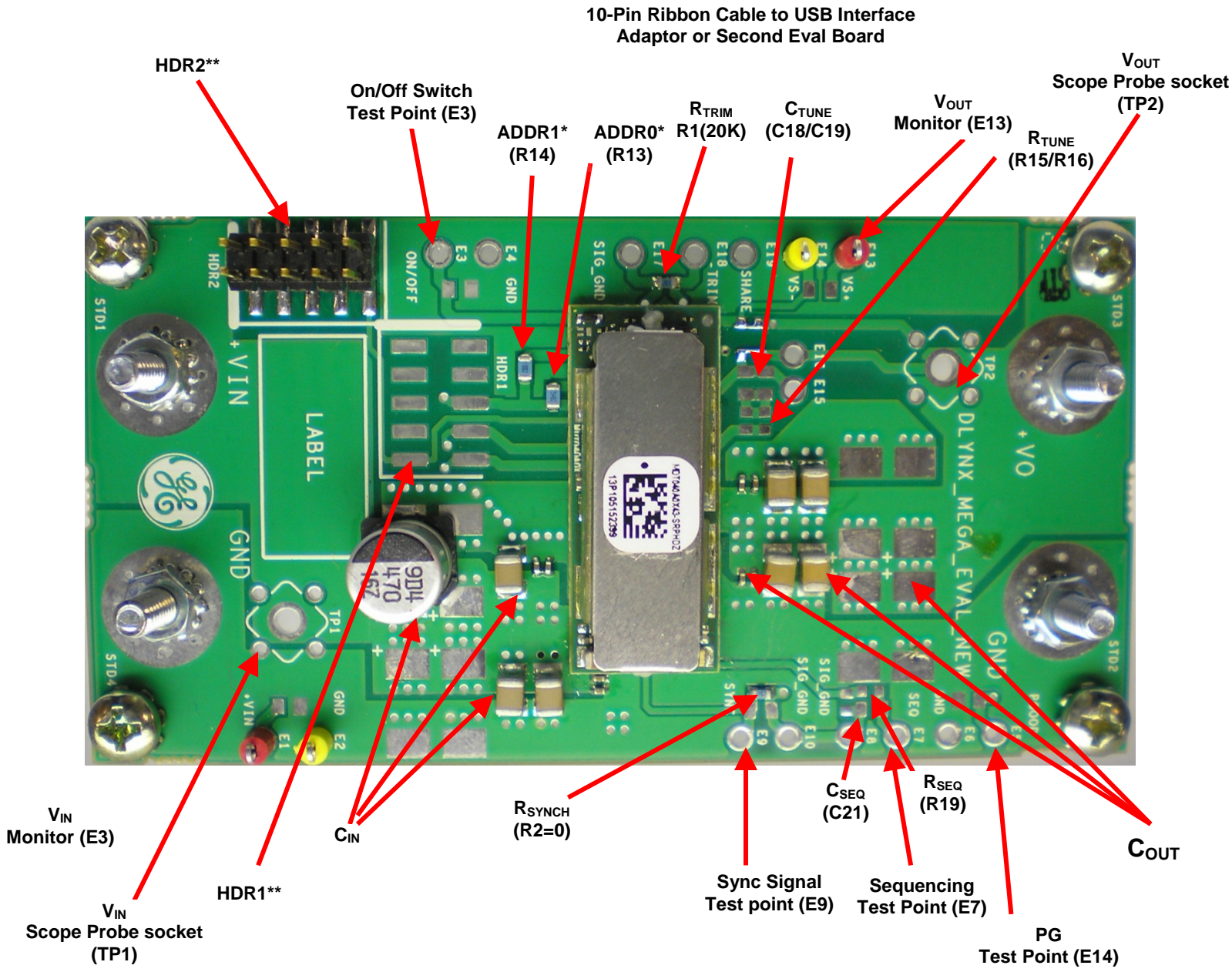

Figure 7. Power and Analog Signal Interface for the MDT/MVT040 Eval Board

Caution! Before applying power, make sure that the externally installed capacitors (input & output) have appropriate voltage and polarity ratings based on the application.

Notes: Module can be trimmed either by soldering a different fixed resistor(s) @ R₁ or by attaching a potentiometer/resistor between test points E₁₇ and E₁₈.

Analog and Digital Dlynx™: Non-Isolated DC-DC Power Modules

3A to 40A Output Current converters

Pre-Installed components for the MegaDlynx™ - Input filtering [C₁₄,C₅₁ (0.047uF,50V), C₁₃,C₁₅,C₁₆(10uF,50V), Output filtering [C₂₀,C₂₁,C₅₂,C₅₃(0.047uF,50V),C₂₂,C₂₃,C₂₄,C₂₅ (4x10µF,50V)], R_{SENSE} resistors, R₁₇ & R₁₈ = 0 Ohms, Trim R₁=20K and some test points.

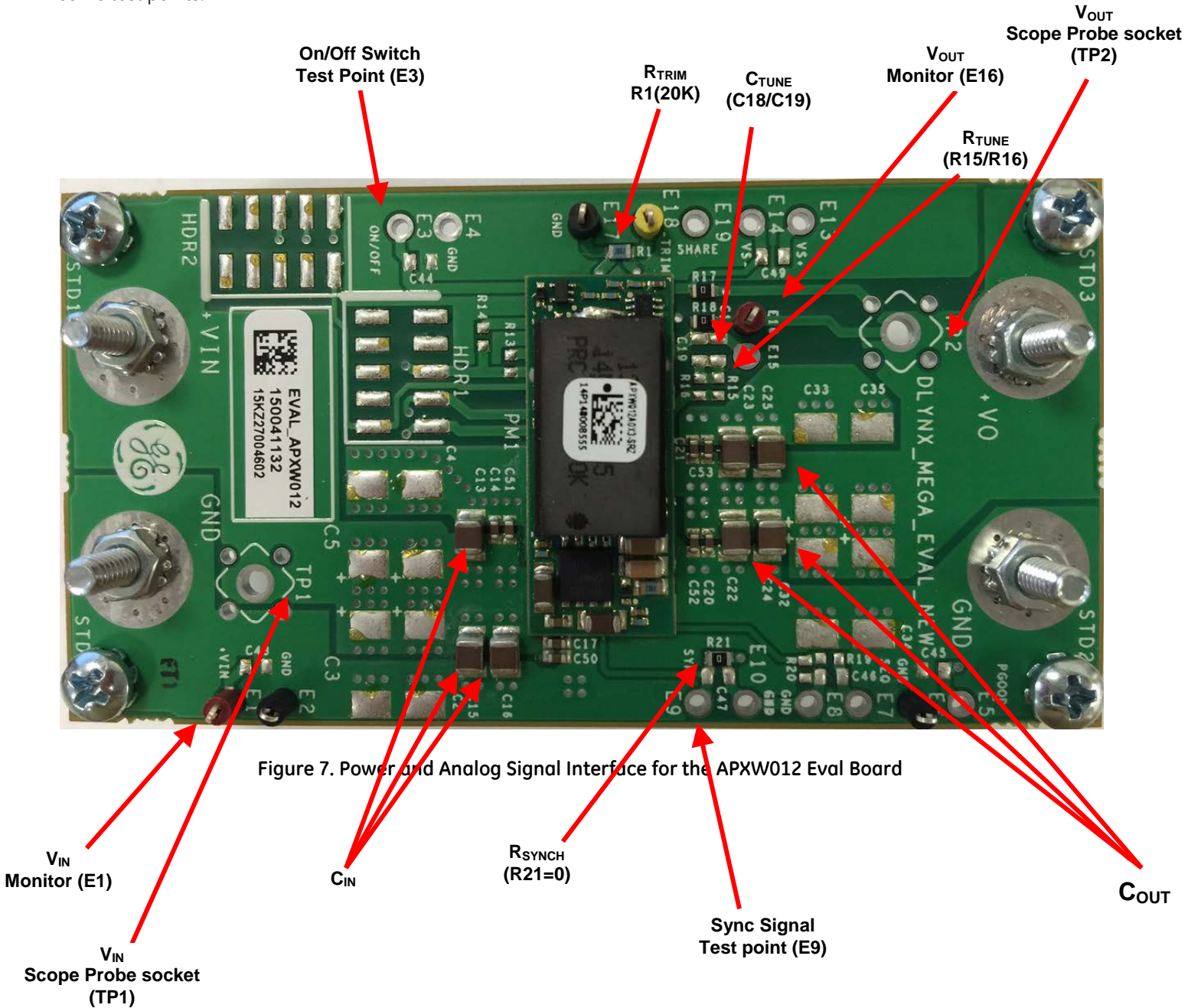

Figure 7. Power and Analog Signal Interface for the APXW012 Eval Board

Caution! Before applying power, make sure that the externally installed capacitors (input & output) have appropriate voltage and polarity ratings based on the application.

Notes: Module can be trimmed either by soldering a different fixed resistor(s) @ R₁ or by attaching a potentiometer/resistor between test points E₁₇ and E₁₈. Remember to remove existing trim resistor

Analog and Digital DLynx™: Non-Isolated DC-DC Power Modules 3A to 40A Output Current converters

An annotated photograph of the Dual Layout PicoDLynx™/MicroDLynx™ evaluation board is shown in Figs. 8, 9 and 10 below. The minimum set of external components consists of the trim resistor R5/R6, input filtering (C7, C8 = 2 x 22µF/16V ceramic capacitors are recommended as a minimum and one 470µF/16V electrolytic (C3) for bench testing. C3, C7 & C8 come pre-assembled on the board) and some modest amount of output filtering 22µF (minimum) ceramic (C11=22µF/16V pre-assembled on the board). Additionally, the following components are preinstalled:

R_{SENSE} resistors, R7 & R10 = 0 Ohms, R_{SYNCH} resistor, R11=10K, R_{TRIM}=20K, Address R15=54.9K, R14=36.5K

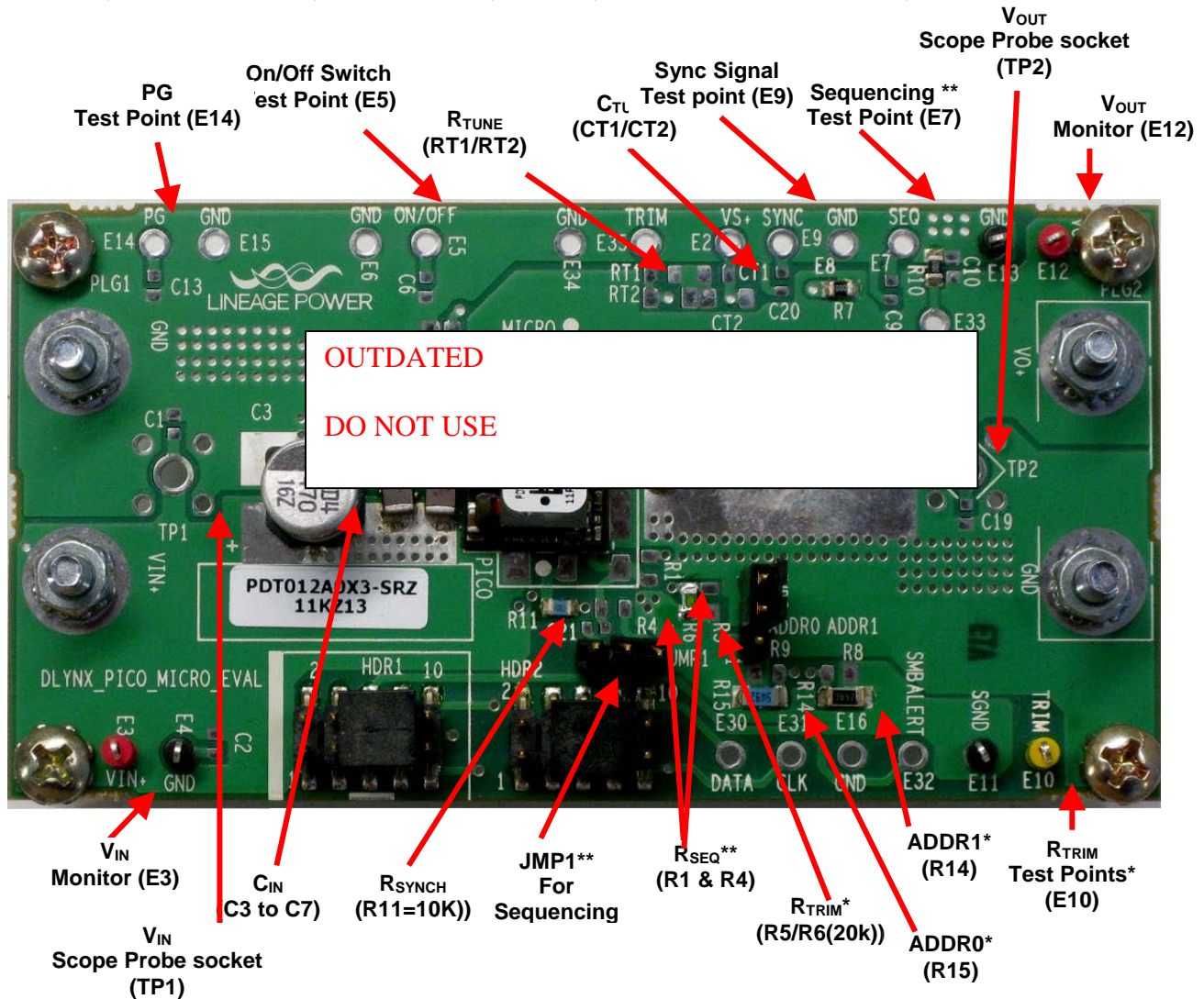

Figure 8. Power and Analog Signal Interface for the Dual Layout PDT012 Eval Board

Caution! Before applying power, make sure that the externally installed capacitors (input & output) have appropriate voltage and polarity ratings based on the application.

Notes:

- * Module can be trimmed either by soldering fixed resistor(s) @ R5/R6 or by attaching a potentiometer/resistor between test points E10 and E11.
- ** Place Shorting Jumper (JMP1) on the left two pins (as shown) when NOT testing for sequencing (SEQ pin open). When testing for Sequencing, place JMP1 on the right two pins and select/install R_{SEQ} resistors, R1 & R4. For further details see the module's data sheet and Application Note AN04-008 "Application Guidelines for Non-Isolated Converters: Guidelines for Sequencing of Multiple Modules".

Analog and Digital Dlynx™: Non-Isolated DC-DC Power Modules

3A to 40A Output Current converters

The minimum set of external components consists of the trim resistor R5/R6, input filtering (C7, C8 = 2 x 22µF/16V ceramic capacitors are recommended as a minimum and one 470µF/16V electrolytic (C3) for bench testing. C3, C7 & C8 come pre-assembled on the board) and some modest amount of output filtering 22µF (minimum) ceramic (C11=22µF/16V pre-assembled on the board). Additionally, the following components are preinstalled: R_{SENSE} resistors, R7 & R10 = 0 Ohms, R_{SYNCH} resistor, R11=10K, R_{TRIM}=20K, Address R15=54.9K, R14=36.5K

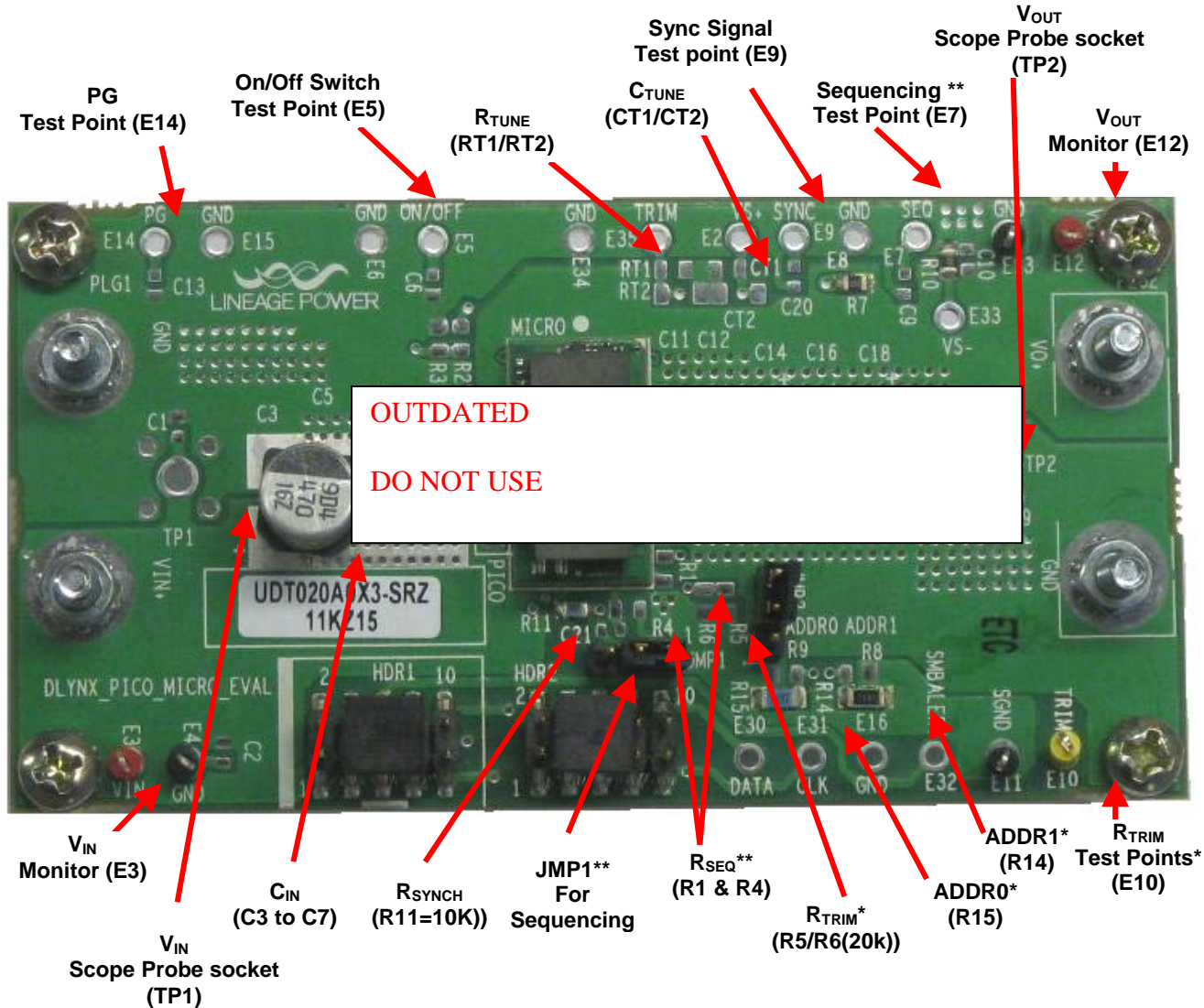

Figure 9. Power and Analog Signal Interface for the Dual Layout UDT020 Eval Board

Caution! Before applying power, make sure that the externally installed capacitors (input & output) have appropriate voltage and polarity ratings based on the application.

Notes:

* Module can be trimmed either by soldering fixed resistor(s) @ R5/R6 or by attaching a potentiometer/resistor between test points E10 and E11.

** Place Shorting Jumper (JMP1) on the left two pins (as shown) when NOT testing for sequencing (SEQ pin open). When testing for Sequencing, place JMP1 on the right two pins and select/install R_{SEQ} resistors, R1 & R4. For further details see the module’s data sheet and Application Note AN04-008 “Application Guidelines for Non-Isolated Converters: Guidelines for Sequencing of Multiple Modules”.

Analog and Digital Dlynx™: Non-Isolated DC-DC Power Modules
 3A to 40A Output Current converters

Digital Interface: The components and test points highlighted in the following figure can be used to evaluate PMBus Digital Interface functionality for the Digital Dlynx™ modules.

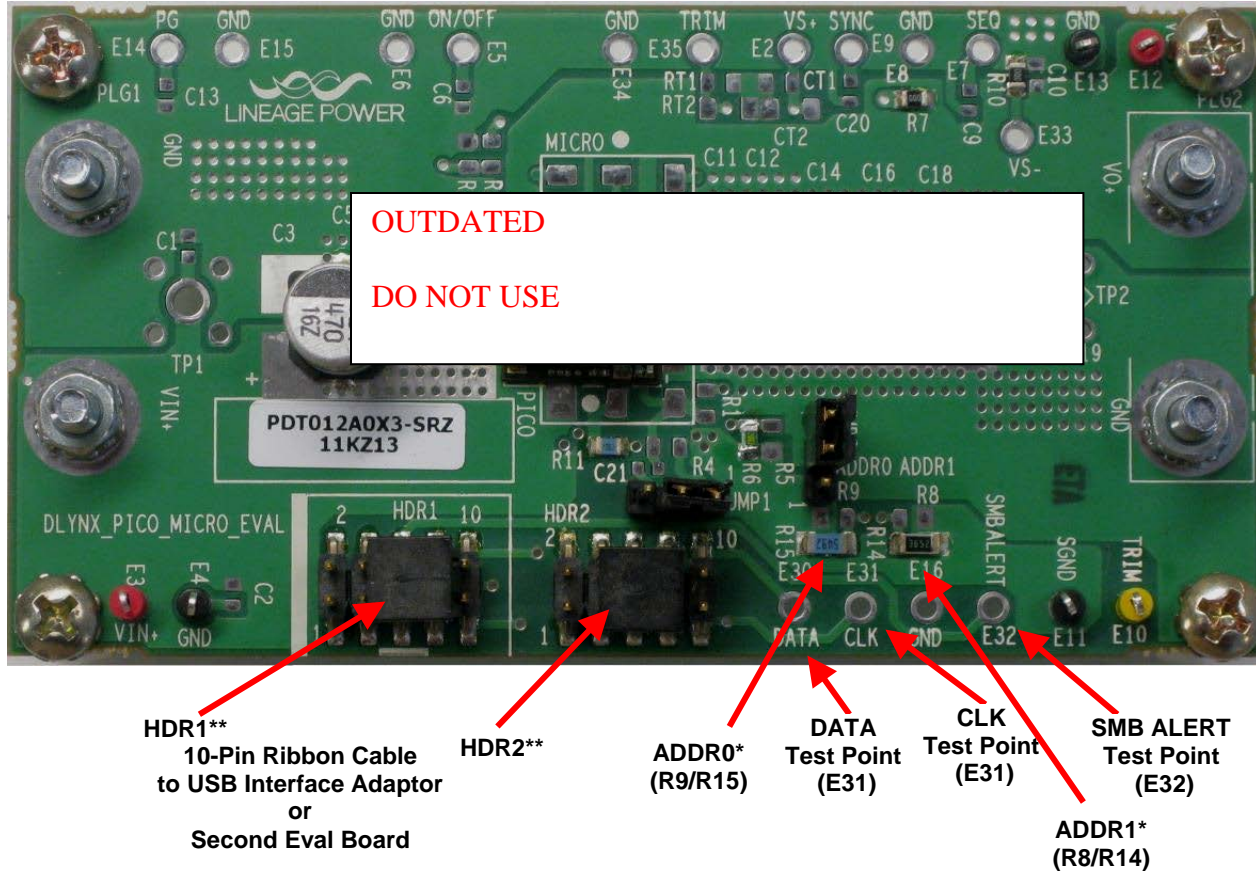

Figure10. PMBus Digital Interface for the Dual Layout Board

Notes:

* The digital Dlynx Module can be assigned a specific address by connecting resistors (R9/R15) from the ADDR0 pin to GND and resistors (R8/R14) from the ADDR1 pin to GND. The evaluation board comes with preinstalled ADDR1 resistor, R14=36.5K and ADDR0 resistor, R15=54.9K as an example. These values correspond to Octal digits "3 4" equivalent to HEX number "1C" (equivalent to 28 decimal). Please refer to the data sheet for additional details.

** HDR1/HDR2 allow the unit on the Eval board to interface (via 10 pin Ribbon Cable) with another unit on a different Eval Board and/or to GE's "USB Interface Adapter" module in order for multiple modules to be controlled by the GUI. For further details, please refer to the GE document, "Digital Power Insight™ User Manual".

Note1: The red wire on the ribbon cable should be aligned to Pin 1 (left side) of the HDR1 or HDR2 connectors.

Note2: Headers and Ribbon Cable Assembly details:

Part Description (HDR1 & HDR2): 10-Pin Dual Row Male Pin Header, SMT
 e.g. FCI P/N: 95157-210 (Digi-Key P/N: 95157-210-ND) or Molex P/N: 0015910100

Part Description: IDC Ribbon Cable Assembly
 e.g.: 3M P/N: M3DDA-1018J (Digi-Key P/N: M3DDA-1018J-ND) or Molex P/N: 111062-022

Analog and Digital Dlynx™: Non-Isolated DC-DC Power Modules

3A to 40A Output Current converters

Dual Layout 12A/6A/3A Analog PicoDlynx™ :

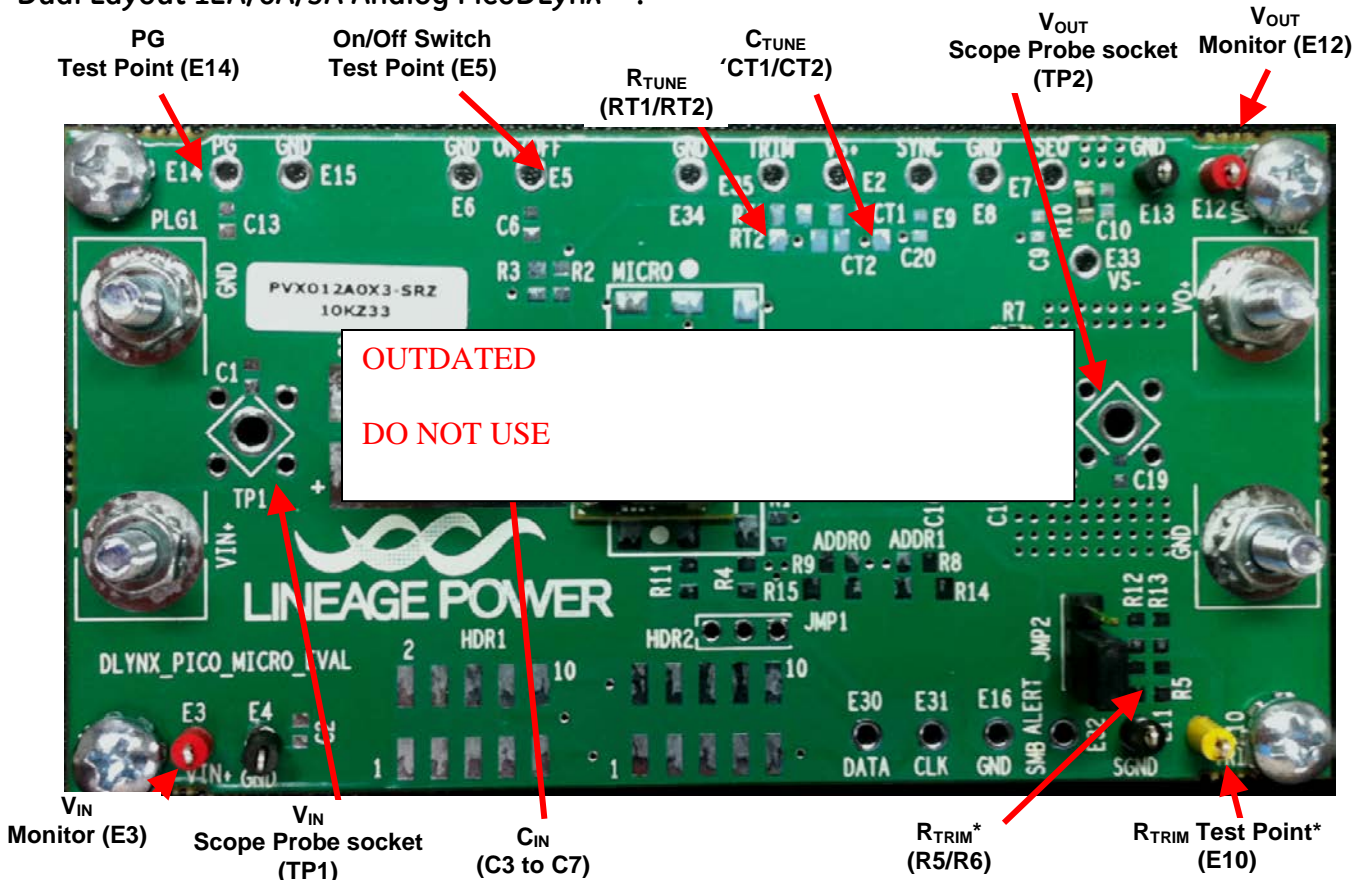

Figure 11. Analog Dual Layout 12A PicoDlynx (PVX012A0X) Interface

Note1: Place Shorting Jumper (JMP2) on the bottom two pins as shown (SGND and GND will be shorted) or place R_{TRIM} resistors on pads identified as R12 & R13. (Other versions of this evaluation board may not have R12 & R13 pads).

Contact Us

For more information, call us at
USA/Canada:

+1 877 546 3243, or +1 972 244 9288

Asia-Pacific:

+86.021.54279977*808

Europe, Middle-East and Africa:

+49.89.878067-280

www.gecriticalpower.com



GE Critical Power reserves the right to make changes to the product(s) or information contained herein without notice, and no liability is assumed as a result of their use or application. No rights under any patent accompany the sale of any such product(s) or information.