

Phase-1 with new JEP

Uli Schäfer
Johannes Gutenberg-Universität Mainz

New Jet/Energy processor

- JEP will be of very old age by time of phase-1 upgrade
 - Limited availability of spares
 - FPGAs not supported by current design tools
- LArg signals will be available optically at high granularity for phase 1
- Tile optical signals might become available at a later stage

JEP comprised of JEMs, based on modular concept (mezzanines)

→ Staged upgrade of JEP, so as to guarantee smooth changeover.

Minimal approach:

- Increase JEM optical output capacity by renewal of low-cost daughter modules
- Add nJEP processor next to topology processor module, to receive JEM optical real-time output
- Keep JEP running while nJEP being commissioned...
- Eventually switch to nJEP based jet trigger
- Use old JEMs for e/o conversion of tile signals only
- Replace JEMs with simple and cheap converter modules as further spares are required
- In case we were running into a latency crisis, full JEP replacement by o/e converter modules would be effective and affordable

Phase-1 upgrade with new JEP

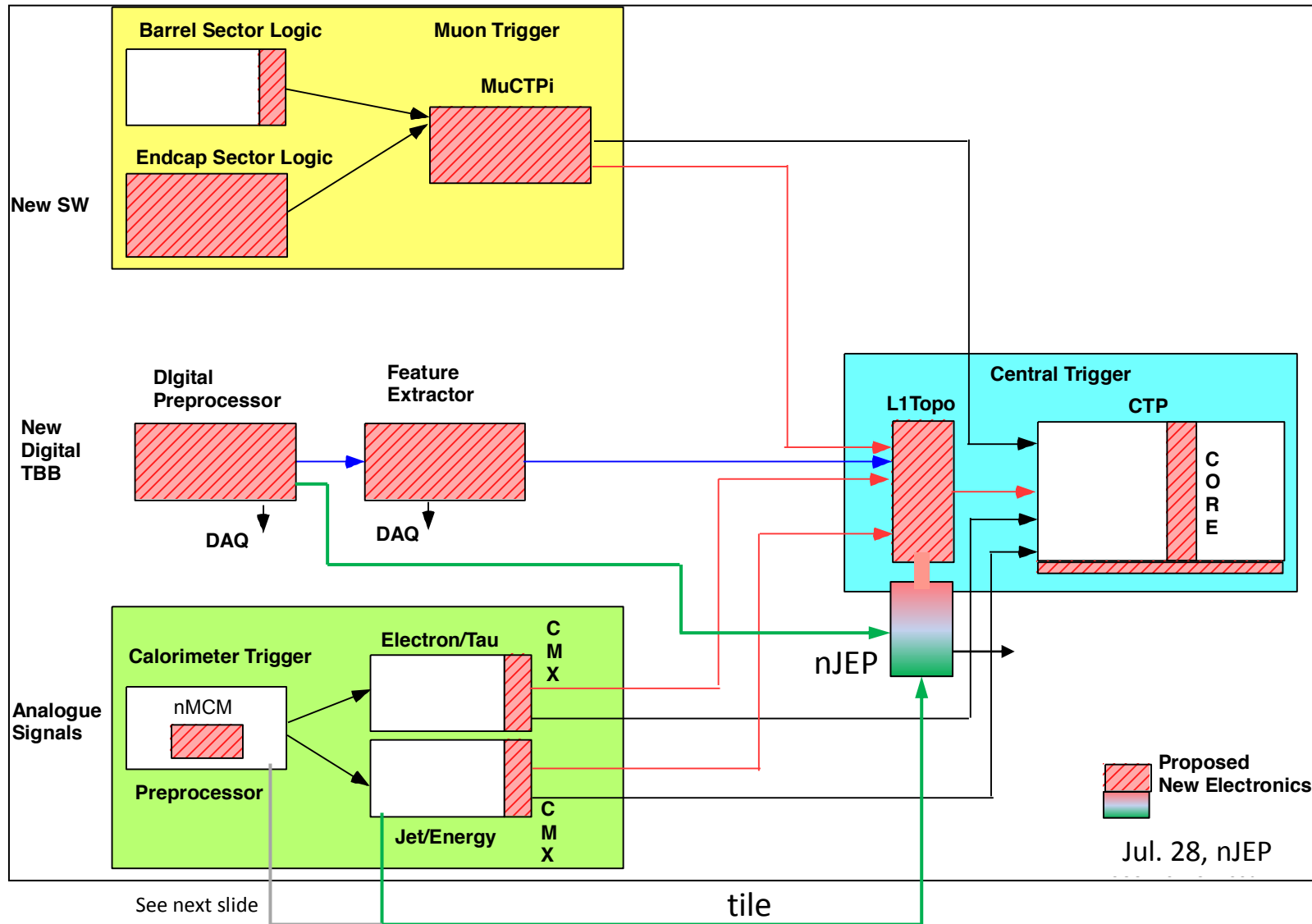

nJEP : improving performance

- Minimal approach is basically just a replacement of aging JEP
- nJEP to provide plenty of spare input capacity. Use it for considerable improvement of physics performance
 - Improve algorithms by making use of finer granularity available from DPP
 - Consider feeding nJEP directly from PPr, at granularity of up to 0.1×0.1 in $\eta \times \phi$
 - Switch to high granularity optical input directly from tile, as it becomes available
- nJEP to be built phase-2 compliant !