

Resource sharing in an open source course management environment

Wolfgang Bauer and Gerd Kortemeyer
Michigan State University
East Lansing, Michigan, USA

Creating rich virtual environments for distance education is extremely labor-intensive. We present a free open-source course management system, LON-CAPA, that enables its users to share each others virtual multimedia resources in order to both save time and increase quality while creating materials and administering courses or learning units. An overview of the current use of the system by a consortium of 30 universities and colleges in the USA, Canada, Japan, Israel, and Brazil is given, and some research results on teaching and learning effectiveness are presented. We also show how one can use the LON-CAPA course management system to provide an interface between publishers and academia, and how to set up an educational object economy for resources stored within the system.

Introduction

During the last decade we have seen a huge increase in distance education due to the emergence of the Internet as a global delivery vehicle for online content. The general availability of world-wide-web browsers on practically all computer platforms and the simple universal html platform had initially enabled fairly straightforward translation of conventional correspondence-course content for distribution on the Internet. However, the use of multimedia and the immediate interactivity that computers connected to the Internet afford has led to the creation much richer learning environments. These new environments include means of synchronous and asynchronous communication between different learners, between learners and teachers, and to a certain degree also between learners and the computer that serves the content. In addition, one can now create learning environments that can be tailored to individual needs of the learner, letting them test out and thus skip over materials they have already mastered or letting them focus additional attention on parts of the curriculum where shortcomings were discovered.

As information technology progresses there are several new challenges that have to be overcome. One of these is the problem of limited bandwidth and dispersion of quality of access to the world-wide-web. Some users have high-speed broadband connectivity of 10 Mbaud or even more, enabling them to make use of video-on-demand technology. Other users have to rely on dial-up phone connections that are more than two orders of magnitude slower, and which make even the download of a large graphic a challenge to the patience of the user. This dispersion in bandwidth access can be alleviated partially by making use of vector graphics and/or moving to a hybrid delivery mode, where one combines the interactivity afforded by the Internet with distribution of bandwidth-intensive content via CD or DVD.

The biggest new challenge in the creation of online content is, however, the time required to create media-rich learning environments. An average college or university teaching professional simply does not have the time to design, develop, test, and periodically update an entire course to cutting-edge standards in technology and pedagogy – at least not when also attempting to

maintain an active research program or family life. Many publishing companies have recognized this problem and have begun to offer online/CD/DVD supplements for their textbooks. However, generally these supplements cannot be customized, as they are necessarily tied to a particular textbook. Using such a canned solution is, of course, not satisfying for a teaching professional, because they do not afford the possibility to engage in creative modification of the source materials.

LON-CAPA

In order to enable instructors to create and/or assemble reusable learning resources, as well as to provide a platform for individualized testing, we developed the Learning *Online* Network with Computer-Assisted Personalized Approach (LON-CAPA) system. LON-CAPA is the combination of a course management system, an individualized assessment system, and a learning resources management system. LON-CAPA is free open source software, was originally developed at Michigan State University, and has its roots in the earlier software systems CAPA (Kashy et al., 1995), Multimedia Physics (Bauer, Benenson, and Westfall, 1992), and LectureOnline (Kortemeyer and Bauer, 1999).

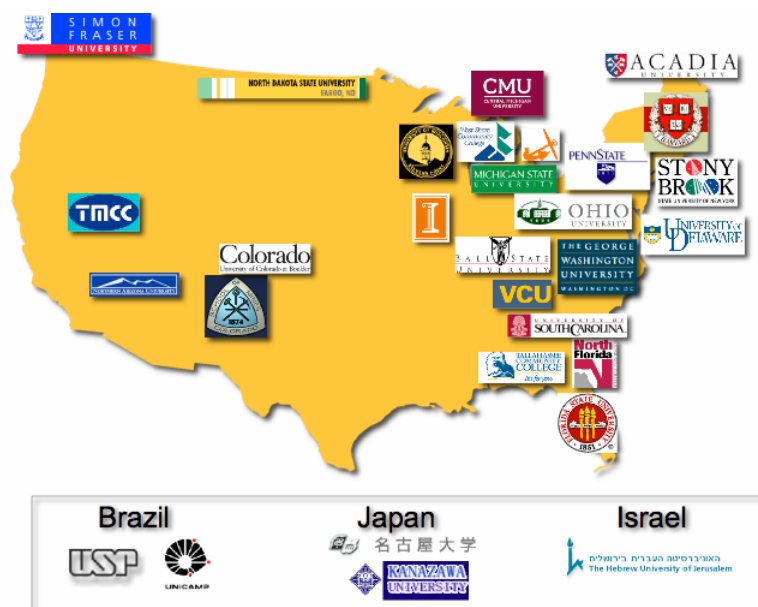

Figure 1 Current LON-CAPA member universities and colleges

The physical implementation of the LON-CAPA infrastructure is a geographically distributed network of persistently connected servers at participating institutions. Each partner institution has to provide at least one server, but can set up any number of servers within their domain, depending on the workload. Within LON-CAPA, so-designated learning resources are shared among all participating instructors, who can assemble their courses from the currently over 60,000 resources (20,900 html content pages, 18,600 homework problems, 12,500 images and graphs, 2,100 content assemblies, 700 animations, 500 movies, and 400 simulations) in the shared resource pool. They can also author new resources, and decide to make these available to other instructors. These resources are distributed across many different subject areas (physics, chemistry, biology, mathematics, statistics, geology, food science, and others) and can be assembled at different levels of granularity: fragments into pages, pages into modules, modules into chapters, chapters into courses etc.

These resources include personalized assignments, quizzes, and examinations with a large variety of conceptual and quantitative problem functionality. In particular, the system provides ample functionality to develop problems which differ from student to student (different numbers, graphs, tables, animations, options, etc), thus encouraging student collaboration on a conceptual level without being able to simply exchange the answers. Feedback from these

resources is immediately available, not only to the learner, but also to the instructor (Albertelli, 2002), on the basis of the individual student or in summary form for the entire class. In Figure 2 we show a typical summary feedback screen, as displayed for a course coordinator, identifying the number of students having attempted each homework problem, the average numbers of tries and degree of difficulty for each problem, as well as the number of new student posts in each discussion forum, and other critical information. Besides having tools for formation assessment, LON-CAPA also provides mechanisms for summative assessment, such as bubble-sheet quizzes and exams (Albertelli, 2003).

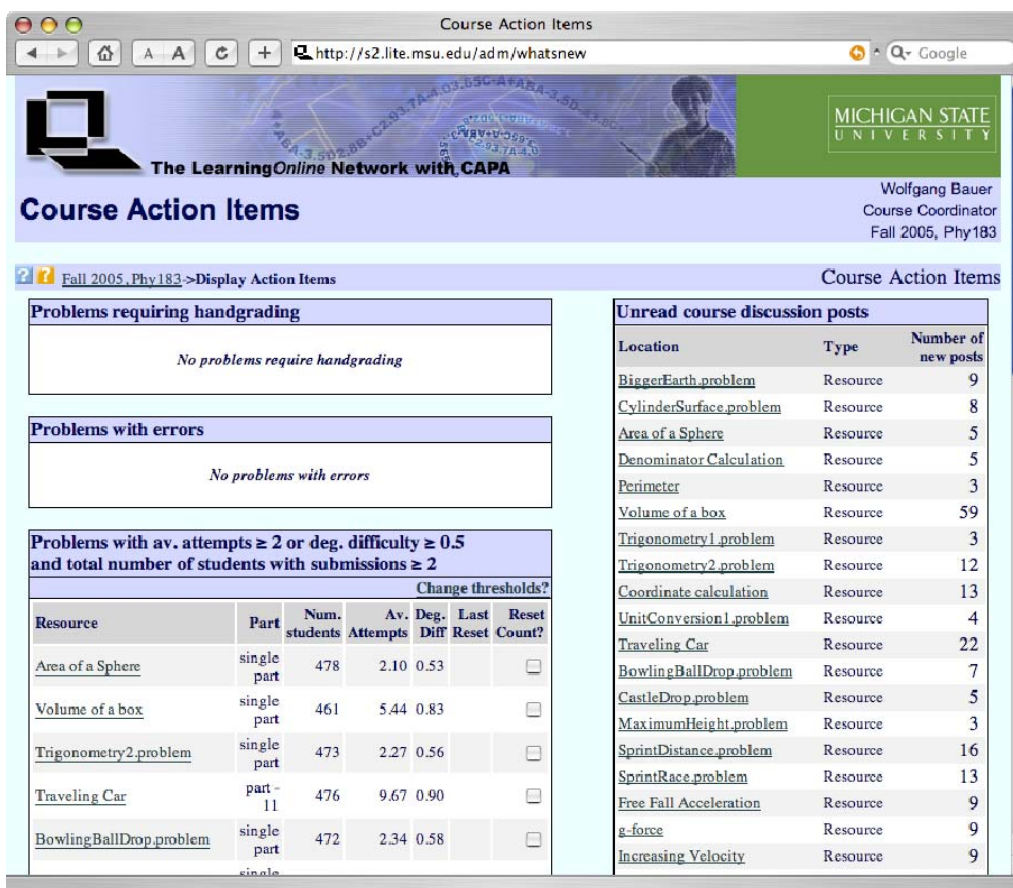

Figure 2 Summary display for course coordinators in LON-CAPA

Reusing online content

The real power of the LON-CAPA system for creation of new modules or entire courses, either for online or for hybrid delivery, is the browse-able and searchable database of online resources contributed by all authors. At the top-level, the LON-CAPA resource pool is organized by domains, which correspond to education institutions (currently approximately 30 universities and colleges, as well as over 20 high and middle schools) and publishing companies. Within each domain the resource tree is organized by authors, and below that level, the organization is the author's responsibility. We have avoided grouping resources by subject, because often one finds that resources are used across multiple disciplines.

In order to provide the 'best' possible resources, one has to apply certain selection criteria. Just like the Google search engine orders the search results by how often other web pages link to a page, we can provide information on how often given resources are used across the LON-CAPA network, as well as information about resources which instructors have chosen in the same context (similar to Amazon.com's 'People who bought this book also ...'), see Figure 3.

Access and Usage Statistics	
Network-wide number of accesses (hits)	890
Number of resources using or importing resource	1 <ul style="list-style-type: none"> • Eukaryotic Gene Control [msu/bio/Gene_Expr/111f03GeneCtr1_sequence]
Number of resources that lead up to this resource in maps	1 <ul style="list-style-type: none"> • Back to the Original Question [msu/bio/Gene_Expr/problems/originalquestion_problem]
Number of resources that follow this resource in maps	1 <ul style="list-style-type: none"> • Eukaryotic vs Prokaryotic Gene Expression II [msu/bio/Gene_Expr/problems/eukvsprokII_problem]
Network-wide number of courses using resource	3 <ul style="list-style-type: none"> • LBS 145 - Spring 2004 • ZOL 341 - Fall 2003 • BS 111 - Fall 2003

Figure 3 Usage statistic metadata for one particular online resource

Usage alone, however, is not enough information. LON-CAPA also provides for statistical metadata, for example the average degrees of difficulty and discrimination for testing resources. In addition, the system also gives individual students the opportunity to rate individual resources in the way shown in Figure 4. Metadata of the kind shown in this figure can be collected, for example, in the framework of honors student projects (Bauer and Kortemeyer, 2005) or simply as part of the regular student feedback process. We find that most students have definite opinions on individual online resources and are more that happy to share these opinions, if appropriately encouraged to do so.

Thus LON-CAPA enables individual authors and instructors to utilize the work of others. The metadata collection and cataloging process enables a selection process that is somewhat similar to a Darwinian selection in biological evolution, where 'fitness' can be measured by numerical metadata, and competing resources can displace each other.

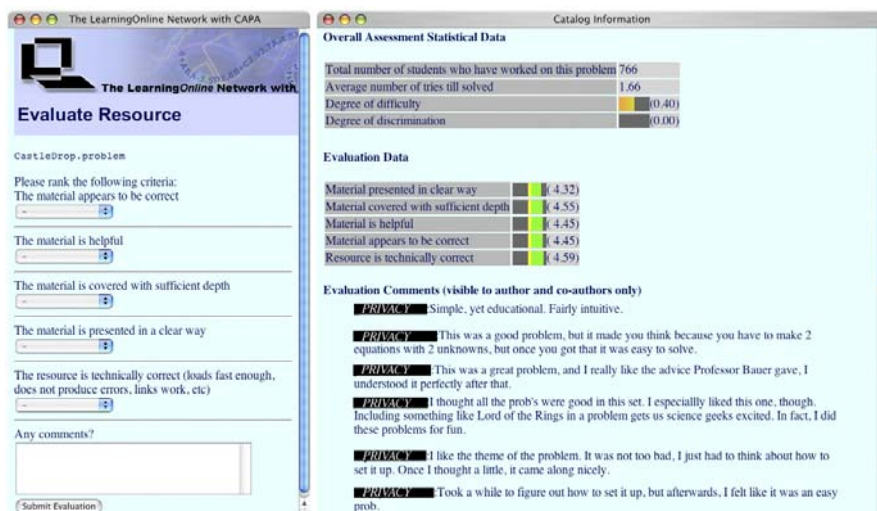

Figure 4 Left side: (student) user interface to evaluate a particular online resource; right side: summary information provided to instructor.

Of course, not all authors are altruistic enough to make all of their work readily available for use free of charge. In particular, textbook authors have a keen interest to protect their intellectual property. Several general textbooks, most notably introductory college physics textbooks, have had all of their end-of-chapter problems coded and individualized in LON-CAPA format. Thus LON-CAPA provides customized 'usage rights' metadata for each resource that determine who in the collaboration is allowed to use it and to what degree.

One can even think of an educational object economy, in which the modes of usage are mixed. In this model, authors can post 'price tags' with their individual online resources. If a resource is made well enough, a textbook/CD/DVD author may want to include this particular resource in her/his publication, as shown in the upper part of Figure 5. After the sale of the final product, the revenue is then shared appropriately among all contributors - compare lower part of Figure 5. It is possible to implement this type of educational object economy within LON-CAPA, but up to now we have no working example for this type of use of the system. Instead, almost all authors are more than happy to post their work for free use for everybody within the LON-CAPA collaboration.

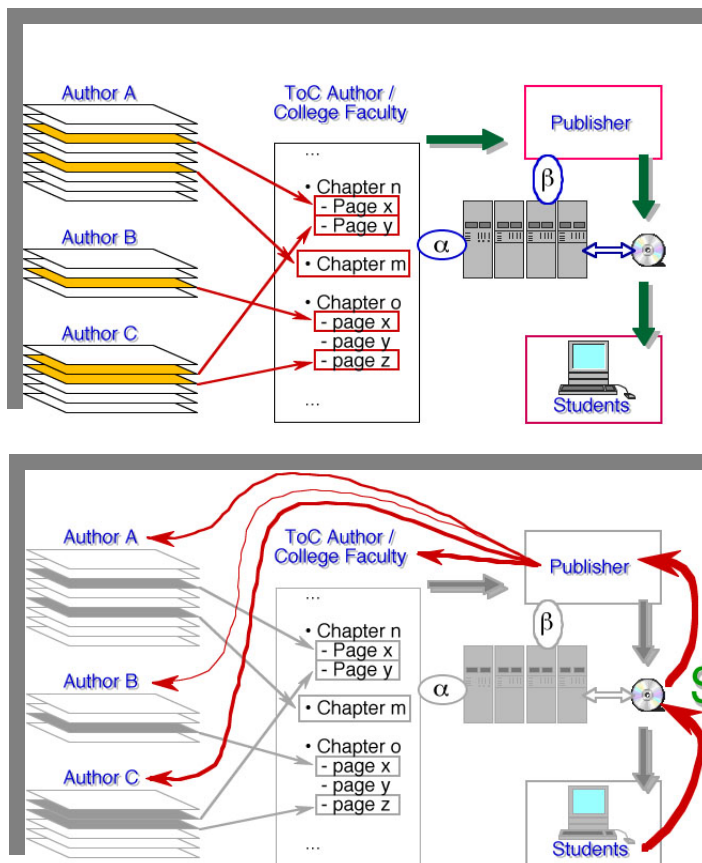

Figure 5 Educational object economy of online resources

Research on teaching and learning with LON-CAPA

In the following we will briefly describe some of the research on teaching that our group has conducted during the last few years, and then we will provide some up to now unpublished results and outline future directions.

Most of our research on teaching and learning was conducted in the framework of large lecture courses or online virtual university courses, predominantly in the introductory physics curriculum (both authors and most of the members of the LON-CAPA group at Michigan State University teach physics). Large enrollment lecture courses provide special challenges, because of the lack of one-on-one feedback for students and professors, because of the large dispersion in preparation and ability of the students, and because of the anonymity of the in-class experience in such courses. Even the best instructors only manage to actively engage a small fraction of their students in real dialog during conventional lectures. Exams are usually of the multiple choice kind, are high stakes, and come as a shock to many students.

LON-CAPA was designed to provide periodic formative assessment feedback. Weekly computer-graded homework assignments with immediate feedback and the possibility to try

repeatedly until successful completion are facilitated within the system. There are some studies that suggest beneficial effects of immediate feedback of the kind given by our system (Azevedo and Bernard, 1995; Mason and Bruning, 2003), but others are not so positive in their verdict (Bonham, Beicher, and Deardorff, 2001; Bransford, Brown, and Cocking, 2000; Kluger and DeNisi, 1996 and 1998). Using our own feedback systems in LON-CAPA and its predecessor systems CAPA and *LectureOnline* no clear picture emerged (Pascarella, 2004; Kotas, 2000).

Members of the LON-CAPA community have conducted a series of before/after studies, in which the performance of students in large lecture classes before and after introduction of LON-CAPA was compared. In one study (Kashy et al., 2001) the authors found that the use of LON-CAPA increases the participation and success of students. The students reported an increase in time-on-task, and they scored higher on standardized exams after introduction of LON-CAPA into their class. Particularly remarkable was the finding that females show a stronger performance enhancement than their male counterparts in their physics classes due to LON-CAPA, welcome news in a field in which females are traditionally an underrepresented minority (see also Kortemeyer and Bauer, 2005).

It is generally understood that the learning process in humans cannot be likened to a simple input-output automaton model. Learning styles, learning needs, learning preferences, learning abilities, and the willingness to learn are just too different from person to person that one model or method can fulfill all of the above optimally for a large group of diverse students. This explains the so-called 'no significant difference' phenomenon which has been observed repeatedly in the literature. In order to address this diversity and dispersion of learning and teaching, LON-CAPA has been designed to accommodate multiple content representations. We are in the beginning stages of implementing meaningful multiple content representations and to provide a test bed setting for further studies (Bauer and Kortemeyer, 2005). Straight html or pdf text and pictures, interactive simulations, streamed 'talking face' lectures, PowerPoint presentations with voice-over narration, and so on, are all under consideration for competing representations. We believe that only through allowing the student sufficient freedom to customize their individual learning environment will we find a measurably positive difference in learning outcomes.

Just as one cannot rely on every student to learn in the same way, one also cannot rely on all students to always play by the rules set up by the instructors. Interestingly, a web site, set up by enterprising students and intended to allow students to solve our individualized homework assignments without doing any of the necessary work, has sprung up. Instead of taking steps to curtail the use of that web site and to take legal steps against it, we have come to see its existence as another research opportunity. Through an email poll we found out which students had used the cheat-site for their homework how often and then correlated the student's success in the in-calls exams and final course grades with this information. (We assured that no grades would be changed as a result of this poll, and we achieved almost 70% participation.) The outcome was statistically very significant: the more students used the cheat-site to short-circuit our individualized homework system, the worse their exam performance became (Kashy et al., 2003). An interesting side note: after we published these findings and shared them with our students, self-reported use of the cheat-site actually went up!

We have just finished a study in which we analyze the learning and teaching benefits of re-taking an exam online for partial credit (Kortemeyer et al., 2005). LON-CAPA facilitates this teaching innovation with ease, measurable positive learning outcomes can be showed, and, perhaps most important, the students are extremely pleased with this innovation.

Audience feedback systems that are used in large lecture settings are becoming more and more prevalent. These usually consist of a touchpad ('clicker') and RF or IR receivers, coupled to a computer that collects the students' responses and provides immediate summary information that can be displayed on computer projectors. LON-CAPA provides basic integration for this technology, so that it can be used as a general purpose tool, from simple attendance-taking, to quick pop quizzes, to sophisticated peer instruction exercises. One of the authors (Kortemeyer) is joining forces with the group of E. Mazur, Harvard, and together they propose to bring the full power of individualization to the peer-instruction use of this feedback system technology, as well as experiment with other IO devices, such as PDAs or smart phones.

LON-CAPA and virtual university courses

Our Lecture *Online* system, one of the predecessors of LON-CAPA was explicitly designed to serve as a platform for the delivery of virtual university courses, and LON-CAPA has followed the implementation of this functionality. Synchronous and asynchronous online communication channels have been built in, facilitating the teaching of virtual university classes. Since 1997 we have offered virtual university classes in introductory physics, and so far more than 2,000 students have successfully completed these courses. In addition, we have designed an Advanced Placement high school online physics course, which is now distributed nationally by Apex Learning (<http://www.apexlearning.com/>). For the latter, we also had to provide online physics laboratory experiences for the students. A sample of these laboratory exercises, in the form of java applets, can be found at <http://chair.pa.msu.edu/applets/labs/labs.htm>.

For all virtual university classes one has to ask if the learning outcomes are comparable to those of corresponding lecture classes. We have run such a study and are reporting its outcome here. We taught a large introductory physics lecture course in two sections and gave another section only in the online format. We made sure that all students received identical computer graded homework assignments and identical examinations. In addition we also administered the Force Concept Inventory (FCI) (Hestenes, Wells, and Swackhammer, 1992) The only difference was that the online section was able to view all materials in form of html pages, graphics files, video clips of lecture demonstrations, and java applet simulations, whereas the lecture-based students had to rely on the in-class lectures and their assigned textbooks. More than 500 students participated in this study. The outcome was both statistically significant and surprising: the virtual university students scored slightly higher on average on all exams, as well as the FCI-measured concept improvement. The average final grades given to these classes, 2.93 in the online class vs. 2.87 vs. the lecture class, both computed on a straight and previously published scale, also reflect this difference.

The interpretation of this comparison is not without difficulty. One could, of course, hypothesize that the online students were forced to engage in more active learning, whereas a certain fraction of the lecture-attending students may have been more passive. However, the populations of the two categories of students were self-selected. The average grade-point average of students in both categories was very close. However, it cannot be ruled out that the students in the online class simply had a greater affinity for the computer and thus chose to spend more time on task with their online physics course, simply because it was fun for them to do so.

Conclusions

LON-CAPA is a universal and fully functional course and learning content management system. Its power derives from freely shared online content and the free open source model for the software itself. The more authors participate in this online exchange, the more powerful this tool becomes, and so we invite all interested parties to join our consortium. LON-CAPA is suitable to deliver online education and has been in continuous use for this purpose since 1997. And LON-CAPA has proved to be a valuable research tool for research on teaching and learning.

Copyright © 2005 Bauer, W. and Kortemeyer, G. The authors assign to ODLAA and educational non-profit institutions a nonexclusive license to use this document for personal use and in courses of instruction provided that the article is used in full and this copyright statement is reproduced. The authors also grant to ODLAA a nonexclusive license to publish this document in electronic or print form within ODLAA publications and/or the world wide web. Any other usage is prohibited without the express permission of the authors.

References

- Albertelli, G., Minaei-Bidgoli, B., Punch, W. F., Kortemeyer, G. & Kashy, E. (2002). Concept feedback in computer-graded assignments. *Proceedings - IEEE Frontiers in Education* 32.
- Albertelli, G., Kortemeyer, G., Sakharuk, A. & Kashy, E. (2003). Personalized examinations in large on-campus classes. *Proceedings - IEEE Frontiers in Education* 33.
- Azevedo, R. & Bernard, R.M. (1995). A meta-analysis of the effects of feedback in computer-based instruction. *Journal of Educational Computer Research*, 13, p.111.
- Bauer, W., Benenson, W. & Westfall, G.D. (1992). *Multimedia physics*, CD ROM (1992)
- Bauer, W., Benenson, W. & Westfall, G.D. (n.d.). MultiMedia physics, retrieved on Sept. 27, 2005 from <http://www.pa.msu.edu/~bauer/mmp/>
- Bauer, W. & Kortemeyer, G. (2005). Research on learning in lon-capa: Multiple content representations, test data banks. In Z.C. Zacharia & C.P. Constantinou (Eds.), *Computer based learning in science*. (pp.189 ff). Conference Proceedings 2005, University of Zilina, Slovakia.
- Bonham, S., Bleicher, R. & Deardorff, D.L. (2001). Online homework: Does it make a difference? *The Physics Teacher*, 39 (5), p.293.
- Bransford, J.D., Brown, A.L. & Cocking, R.R. (eds.) (2000). *How people learn: Brain, mind, experience, and school*. Washington D.C.: National Academy Press.
- Hestenes, D., Wells, M. & Swackhamer, G. (1992). Force concept inventory. *The Physics Teacher*, 30, pp.141ff.
- Kashy, D.A., Albertelli, G., Kashy, E. & Thonnessen, M. (2001). Teaching with ALN technology: Benefits and costs, *Journal of English Educators*, 90 (4), pp.499ff.
- Kashy, D.A., Albertelli, G., Bauer, W., Kashy, E. & Thoennessen, M. (2003). Influence of non-moderated and moderated discussion sites on student success. *Journal of Asynchronous Learning Networks* 7, Issue 1, 31, http://www.aln.org/publications/jaln/v7n1/v7n1_kashy.asp
- Kashy, E., Gaff, S. J., Pawley, N., Stretch, W. L., Wolfe, S., Morrissey, D. J. & Tsai, Y. (1995). Conceptual questions in computer-assisted assignments, *American Journal of Physics*, 63 (11), pp.1000ff.
- Kluger, A.N. & DeNisi, A. (1996). The effects of feedback interventions on performance: Historical review, a meta-analysis and a preliminary feedback intervention theory. *Psychological Bulletin*, 119, pp.254ff.
- Kluger, A.N. & DeNisi, A. (1998). Feedback interventions: Toward the understanding of a double-edged sword, *Current Directions in Psychological Science*, 7, pp.67ff.
- Kortemeyer, G., et al. (n.D.). The LearningOnline Network with CAPA. Retrieved on Sept. 27, 2005 from <http://lon-capa.org/>
- Kortemeyer, G. & Bauer, W. (1999). Multimedia Collaborative Content Creation (mc³) - The MSU LectureOnline System, *J. Eng. Educ.* 88 (4), 405.
- Kortemeyer, G. & Bauer, W. (2005). LON-CAPA, An open-source freeware learning content management and course management system. In Z.C. Zacharia & C.P. Constantinou (Eds.), *Computer based learning in science*, (pp. 211ff). Conference Proceedings 2005, University of Zilina, Slovakia.
- Kortemeyer, G., Bauer, W., Benenson, W. & Kashy, E. (2005). Re-Taking a Test Online. *The Physics Teacher*. Accepted for publication.
- Kotas, P. (2000). Homework behavior in an introductory physics course. M.S. thesis, Central Michigan University.

Mason, B. & Bruning, R. (2003). Providing feedback in computer-based instruction: What the research tells us. Retrieved September 27 2005 at <http://dwb.unl.edu/Edit/MB/MasonBruning.html>

Pascarella, A.M. (2004). The influence of web-based homework on quantitative problem-solving in a university physics class. In *Proceedings NARST (National Association for Research in Science Teaching) Annual Meeting, 2004*.

Acknowledgements

Research funding provided by the US National Science Foundation through an Information Technology Research grant.