

3 Axis MEMs Accelerometer Box Electronics

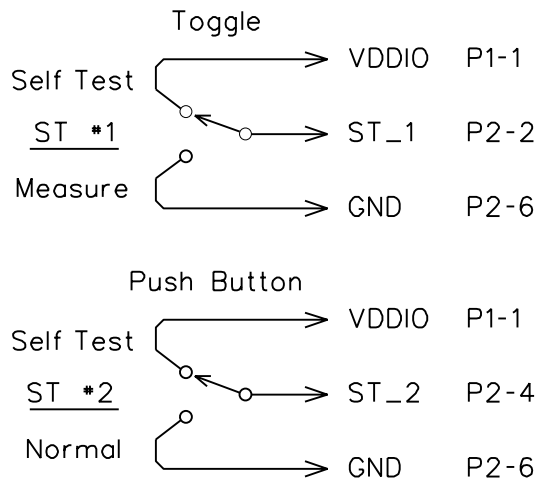

See also EVAL-ADXL354 Demo Board Data Sheet

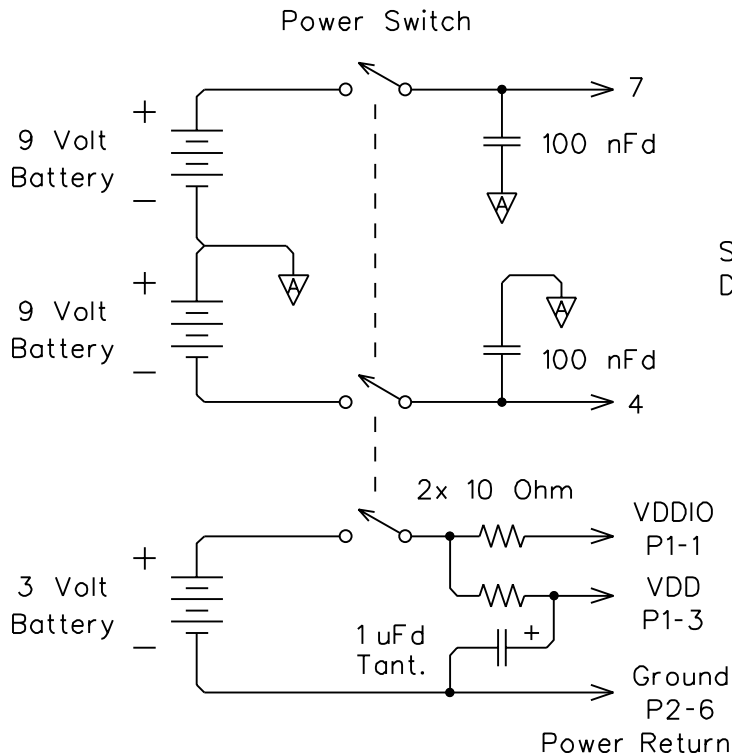
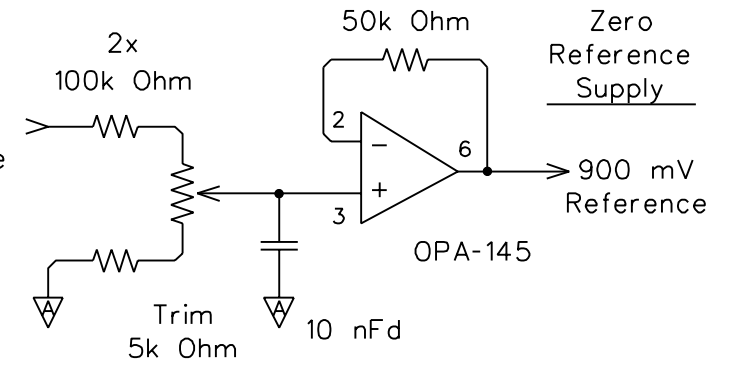
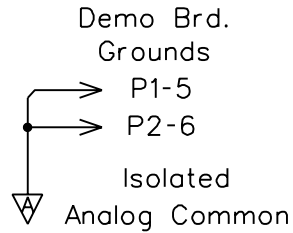

No Connexion to Demo Brd P2-3 & P2-5



X, Y, Z Diff. Output Amps

