

TPS22996 5.5-V, 4-A, 14-mΩ On-Resistance Dual-Channel Load Switch

1 Features

- Integrated dual-channel load switch
- V_{IN} voltage range: 0.6 V to V_{BIAS}
- V_{BIAS} voltage range: 2.5 V to 5.5 V
- On-resistance: 14 mΩ (typical)
- 4-A maximum continuous switch current per channel
- Quiescent current:
 - $I_Q = 16 \mu\text{A}$ (typical, both channels) at $V_{IN} = V_{BIAS} = 5 \text{ V}$
 - $I_Q = 13 \mu\text{A}$ (typical, single channel) at $V_{IN} = V_{BIAS} = 5 \text{ V}$
- Control input threshold enables use of 1.2-, 1.8-, 2.5-, and 3.3-V logic
- Configurable rise time
- Thermal shutdown
- Quick Output Discharge (QOD) (optional)

2 Applications

- [PC and notebooks](#)
- [Set-top boxes and residential gateways](#)
- [Telecom systems](#)
- [Solid-state drives \(SSD\)](#)

3 Description

The TPS22996 product family consists of two devices: TPS22996 and TPS22996N. Each device is a dual-channel load switch with controlled turnon. The device contains two N-channel MOSFETs that can operate over an input voltage range of 0.6 V to 5.5 V, and can support a maximum continuous current of 4 A per channel. Each switch is independently controlled by an on and off input (ON1 and ON2), which can interface directly with low-voltage control signals. The TPS22996 is capable of thermal shutdown when the junction temperature is above the threshold, turning the switch off. The switch turns on again when the junction temperature stabilizes to a safe range. The TPS22996 also offers an optional integrated 230-Ω on-chip load resistor for quick output discharge when the switch is turned off.

The TPS22996 is available in a small, space-saving 2.1-mm × 1.6-mm 8-DRL Package with leads to enable low cost manufacturing. The device is characterized for operation over the free-air temperature range of -40°C to 105°C .

Package Information

| PART NUMBER | PACKAGE ⁽¹⁾ | PACKAGE SIZE ⁽²⁾ |
|-------------|------------------------|-----------------------------|
| TPS22996 | DRL (SOT, 8) | 2.10 mm × 1.60 mm |

(1) For all available packages, see the orderable addendum at the end of the data sheet.

(2) The package size (length × width) is a nominal value and includes pins, where applicable.

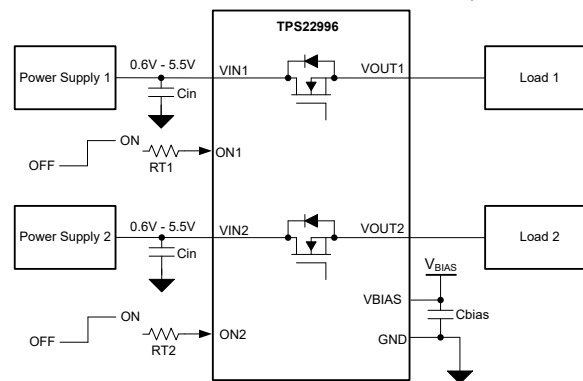

Application Circuit



Table of Contents

| | | | |
|---|----|--|----|
| 1 Features | 1 | 8.2 Functional Block Diagram..... | 15 |
| 2 Applications | 1 | 8.3 Feature Description..... | 15 |
| 3 Description | 1 | 8.4 Device Functional Modes..... | 17 |
| 4 Device Comparison Table | 3 | 9 Application and Implementation | 18 |
| 5 Pin Configuration and Functions | 3 | 9.1 Application Information..... | 18 |
| 6 Specifications | 4 | 9.2 Typical Application..... | 18 |
| 6.1 Absolute Maximum Ratings..... | 4 | 9.3 Power Supply Recommendations..... | 20 |
| 6.2 ESD Ratings..... | 4 | 9.4 Layout..... | 20 |
| 6.3 Recommended Operating Conditions..... | 4 | 10 Device and Documentation Support | 22 |
| 6.4 Thermal Information..... | 4 | 10.1 Documentation Support..... | 22 |
| 6.5 Electrical Characteristics..... | 5 | 10.2 Receiving Notification of Documentation Updates.. | 22 |
| 6.6 Switching Characteristics (TPS22996, TPS22996N)..... | 6 | 10.3 Support Resources..... | 22 |
| 6.7 Typical Characteristics: DC..... | 7 | 10.4 Trademarks..... | 22 |
| 6.8 Typical Characteristics: AC..... | 8 | 10.5 Electrostatic Discharge Caution..... | 22 |
| 7 Parameter Measurement Information | 13 | 10.6 Glossary..... | 22 |
| 8 Detailed Description | 14 | 11 Revision History | 22 |
| 8.1 Overview..... | 14 | 12 Mechanical, Packaging, and Orderable Information | 22 |

4 Device Comparison Table

| DEVICE | R_{ON} AT $V_{IN} = V_{BIAS} = 5\text{ V}$ (TYPICAL) | QUICK OUTPUT DISCHARGE | MAXIMUM OUTPUT CURRENT |
|--------------------------|--|------------------------|------------------------|
| TPS22996 | 14 m Ω | Yes | 4 A |
| TPS22996N ⁽¹⁾ | 14 m Ω | No | 4 A |

(1) Device in preview status. Please contact TI for more information.

5 Pin Configuration and Functions

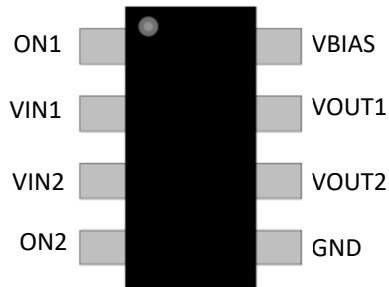

Figure 5-1. DRL Package, 8-Pin SOT (Top View)

Pin Functions

| PIN | | I/O | DESCRIPTION |
|-----|-------|-----|--|
| NO. | NAME | | |
| 1 | ON1 | I | Active-high switch 1 control input. Connect series resistor to set slew rate. Do not leave floating. |
| 2 | VIN1 | I | Switch 1 input. Recommended voltage range for these pins for optimal R_{ON} performance is 0.6 V to V_{BIAS} . Place an optional decoupling capacitor between these pins and GND to reduce V_{IN1} dip during turnon of the channel. |
| 3 | VIN2 | I | Switch 2 input. Recommended voltage range for these pins for optimal R_{ON} performance is 0.6 V to V_{BIAS} . Place an optional decoupling capacitor between these pins and GND to reduce V_{IN1} dip during turnon of the channel. |
| 4 | ON2 | I | Active-high switch 2 control input. Connect series resistor to set Slew Rate. Do not leave floating. |
| 5 | GND | I | Device ground. |
| 6 | VOUT2 | I | Switch 2 output. |
| 7 | VOUT1 | I | Switch 1 output. |
| 8 | VBIAS | I | Bias voltage. Power supply to the device. Recommended voltage range for this pin is 2.5 V to 5.5 V. |

6 Specifications

6.1 Absolute Maximum Ratings

over operating free-air temperature range (unless otherwise noted)⁽¹⁾

| | | MIN | MAX | UNIT |
|----------------------|--|------|-----|------|
| V _{IN1,2} | Input voltage | -0.3 | 6 | V |
| V _{OUT1,2} | Output voltage | -0.3 | 6 | V |
| V _{ON1,2} | ON pin voltage | -0.3 | 6 | V |
| V _{BIAS} | Bias voltage | -0.3 | 6 | V |
| I _{MAX} | Maximum continuous current per channel | | 4 | A |
| I _{MAX,PLS} | Maximum pulsed current switch per channel, pulse <300µs, 3% duty cycle | | 5.5 | A |
| T _J | Junction temperature | | 125 | °C |
| T _{stg} | Storage temperature | -65 | 150 | °C |

- (1) Operation outside the Absolute Maximum Ratings may cause permanent device damage. Absolute Maximum Ratings do not imply functional operation of the device at these or any other conditions beyond those listed under Recommended Operating Conditions. If used outside the Recommended Operating Conditions but within the Absolute Maximum Ratings, the device may not be fully functional, and this may affect device reliability, functionality, performance, and shorten the device lifetime.

6.2 ESD Ratings

| | | | VALUE | UNIT |
|--------------------|-------------------------|---|-------|------|
| V _(ESD) | Electrostatic discharge | Human body model (HBM), per ANSI/ESDA/ JEDEC JS-001, all pins ⁽¹⁾ | ±2000 | V |
| | | Charged device model (CDM), per JEDEC specification JS-002, all pins ⁽²⁾ | ±1000 | |

- (1) JEDEC document JEP155 states that 500-V HBM allows safe manufacturing with a standard ESD control process.
 (2) JEDEC document JEP157 states that 250-V CDM allows safe manufacturing with a standard ESD control process.

6.3 Recommended Operating Conditions

over operating free-air temperature range (unless otherwise noted)

| | | MIN | NOM | MAX | UNIT |
|---------------------|------------------------------|-----|-----|-------------------|------|
| V _{IN1,2} | Input voltage | 0.6 | | V _{BIAS} | V |
| V _{BIAS} | Bias voltage | 2.5 | | 5.5 | V |
| V _{ON1,2} | ON pin voltage | 0 | | 5.5 | V |
| V _{OUT1,2} | Output voltage | 0 | | V _{IN} | V |
| V _{IH} | High-Level input voltage, ON | 1.2 | | 5.5 | V |
| V _{IL} | Low-Level input voltage, ON | 0 | | 0.6 | V |
| T _A | Ambient temperature | -40 | | 105 | °C |

6.4 Thermal Information

| | THERMAL METRIC ⁽¹⁾ | TPS22996 | | UNIT |
|-----------------------|--|-----------|--|------|
| | | DRL (SOT) | | |
| | | 8 PINS | | |
| R _{θJA} | Junction-to-ambient thermal resistance | 115.8 | | °C/W |
| R _{θJC(top)} | Junction-to-case (top) thermal resistance | 48.5 | | °C/W |
| R _{θJB} | Junction-to-board thermal resistance | 20.7 | | °C/W |
| Ψ _{JT} | Junction-to-top characterization parameter | 1 | | °C/W |
| Ψ _{JB} | Junction-to-board characterization parameter | 20.4 | | °C/W |

6.4 Thermal Information (continued)

| THERMAL METRIC ⁽¹⁾ | | TPS22996 | UNIT |
|-------------------------------|--|-----------|------|
| | | DRL (SOT) | |
| | | 8 PINS | |
| $R_{\theta JC(bot)}$ | Junction-to-case (bottom) thermal resistance | N/A | °C/W |

(1) For more information about traditional and new thermal metrics, see the [Semiconductor and IC Package Thermal Metrics](#) application report.

6.5 Electrical Characteristics

over operating free-air temperature range (unless otherwise noted)

| PARAMETER | | TEST CONDITIONS | T_A | MIN | TYP | MAX | UNIT | | | |
|------------------------------------|---|--|------------------|-----------------------------|--|----------------|----------------|------|-----|----|
| Power Supplies and Currents | | | | | | | | | | |
| $I_{Q,VBIAS}$ | V_{BIAS} quiescent current (both channels) | $I_{OUT1} = I_{OUT2} = 0$ mA, $V_{IN1,2} = V_{ON1,2} = 5$ V | -40°C to 85°C | 16 | 22 | | μA | | | |
| | | | -40°C to 105°C | | | 23 | μA | | | |
| | V_{BIAS} quiescent current (single-channel) | $I_{OUT1} = I_{OUT2} = 0$ mA, $V_{ON2} = 0$ V, $V_{IN1,2} = V_{IN1} = 5$ V | -40°C to 85°C | 13 | 20 | | μA | | | |
| | | | -40°C to 105°C | | | 22 | μA | | | |
| $I_{SD,VBIAS}$ | V_{BIAS} shutdown current | $V_{ON1,2} = 0$ V, $V_{OUT1,2} = 0$ V | -40°C to 105°C | 0.1 | 0.5 | | μA | | | |
| $I_{SD,VIN}$ | V_{IN} shutdown current (per channel) | $V_{ON} = 0$ V, $V_{OUT} = 0$ V | $V_{IN} = 5$ V | -40°C to 85°C | 0.010 | 0.5 | | μA | | |
| | | | | -40°C to 105°C | | | 0.8 | μA | | |
| | | | $V_{IN} = 3.3$ V | -40°C to 85°C | 0.010 | 0.5 | | μA | | |
| | | | | -40°C to 105°C | | | 0.8 | μA | | |
| | | | $V_{IN} = 1.8$ V | -40°C to 85°C | 0.010 | 0.5 | | μA | | |
| | | | | -40°C to 105°C | | | 0.8 | μA | | |
| | | | $V_{IN} = 0.6$ V | -40°C to 85°C | 0.001 | 0.3 | | μA | | |
| | | | | -40°C to 105°C | | | 0.8 | μA | | |
| I_{ON} | ON pin leakage current | $V_{ON} = 5.5$ V | -40°C to 105°C | | 0.1 | | μA | | | |
| Resistance Characteristics | | | | | | | | | | |
| R_{ON} | On-Resistance | $I_{OUT} = -200$ mA | $V_{IN} = 5$ V | 25°C | 14 | 18 | mΩ | | | |
| | | | | -40°C to 85°C | | | 21 | mΩ | | |
| | | | | -40°C to 105°C | | | 23 | mΩ | | |
| | | | $V_{IN} = 3.3$ V | 25°C | 14 | 18 | mΩ | | | |
| | | | | -40°C to 85°C | | | 21 | mΩ | | |
| | | | | -40°C to 105°C | | | 23 | mΩ | | |
| | | | $V_{IN} = 1.8$ V | 25°C | 14 | 18 | mΩ | | | |
| | | | | -40°C to 85°C | | | 21 | mΩ | | |
| | | | | -40°C to 105°C | | | 23 | mΩ | | |
| | | | $V_{IN} = 0.6$ V | 25°C | 14 | 18 | mΩ | | | |
| | | | | -40°C to 85°C | | | 21 | mΩ | | |
| | | | | -40°C to 105°C | | | 23 | mΩ | | |
| | | | R_i | Internal on pin resistance | $V_{ON} = 5$ V | $V_{ON} = 5$ V | -40°C to 105°C | 11.5 | | kΩ |
| | | | R_{PD} | Output pulldown resistance | $V_{IN} = V_{OUT} = 5$ V, $V_{ON} = 0$ V | | -40°C to 105°C | 230 | 280 | Ω |
| | | | T_{SD} | Thermal shutdown | Junction temperature rising | - | 150 | 175 | | °C |
| | | | $T_{SD,HYS}$ | Thermal shutdown hysteresis | Junction temperature falling | - | | 20 | | °C |

6.6 Switching Characteristics (TPS22996, TPS22996N)

over operating free-air temperature range (unless otherwise noted)

| PARAMETER | | TEST CONDITIONS | MIN | TYP | MAX | UNIT |
|-------------------------------------|---------------|--|-----|------|-----|------|
| VIN = VON = VBIAS = 5V | | | | | | |
| t _{ON} | Turn ON time | R _L = 10 Ω, C _L = 0.1 μF, I _{ON} = 100 μA | | 1000 | | μs |
| t _{OFF} | Turn OFF time | R _L = 10 Ω, C _L = 0.1 μF, I _{ON} = 100 μA | | 2.3 | | μs |
| t _R | Rise time | R _L = 10 Ω, C _L = 0.1 μF, I _{ON} = 100 μA | | 688 | | μs |
| t _F | Fall time | R _L = 10 Ω, C _L = 0.1 μF, I _{ON} = 100 μA | | 2.12 | | μs |
| t _D | Delay time | R _L = 10 Ω, C _L = 0.1 μF, I _{ON} = 100 μA | | 317 | | μs |
| VIN = 0.6V, VON = VBIAS = 5V | | | | | | |
| t _{ON} | Turn ON time | R _L = 10 Ω, C _L = 0.1 μF, I _{ON} = 100 μA | | 588 | | μs |
| t _{OFF} | Turn OFF time | R _L = 10 Ω, C _L = 0.1 μF, I _{ON} = 100 μA | | 2.3 | | μs |
| t _R | Rise time | R _L = 10 Ω, C _L = 0.1 μF, I _{ON} = 100 μA | | 215 | | μs |
| t _F | Fall time | R _L = 10 Ω, C _L = 0.1 μF, I _{ON} = 100 μA | | 2.12 | | μs |
| t _D | Delay time | R _L = 10 Ω, C _L = 0.1 μF, I _{ON} = 100 μA | | 374 | | μs |

6.7 Typical Characteristics: DC

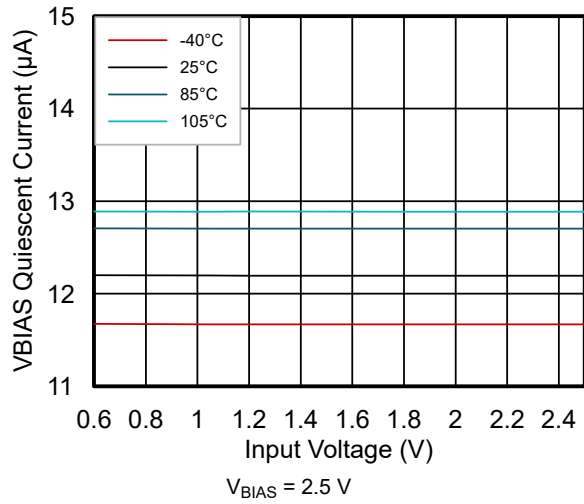

Figure 6-1. V_{BIAS} Quiescent Current vs Input Voltage Single Channel

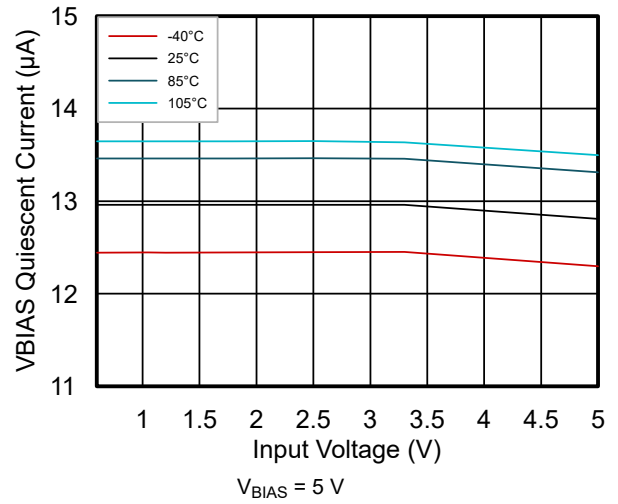

Figure 6-2. V_{BIAS} Quiescent Current vs Input Voltage Single Channel

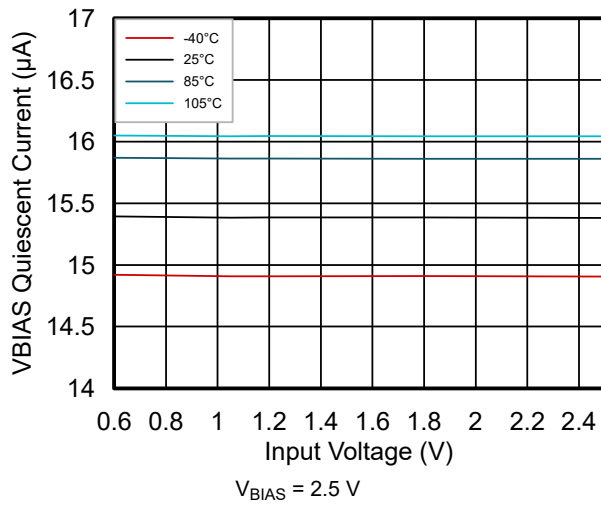

Figure 6-3. V_{BIAS} Quiescent Current vs Input Voltage Both Channels

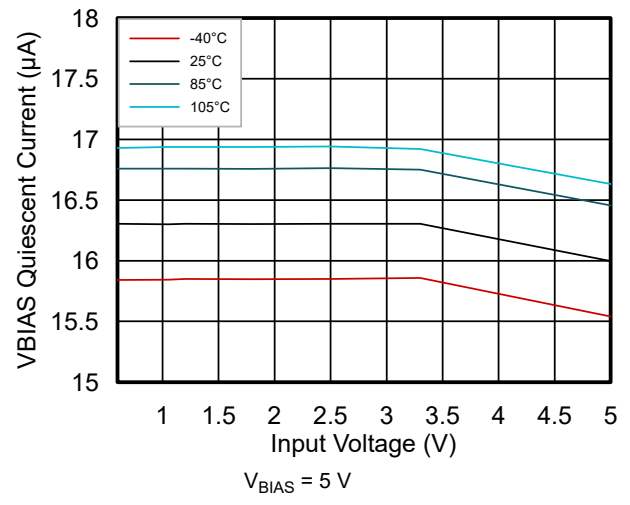

Figure 6-4. V_{BIAS} Quiescent Current vs Input Voltage Both Channels

6.8 Typical Characteristics: AC

$C_{IN} = 1 \mu\text{F}$, $C_L = 0.1 \mu\text{F}$, $R_L = 10 \Omega$, $V_{ON} = 5 \text{ V}$, $I_{ON} = 100 \mu\text{A}$ unless otherwise noticed

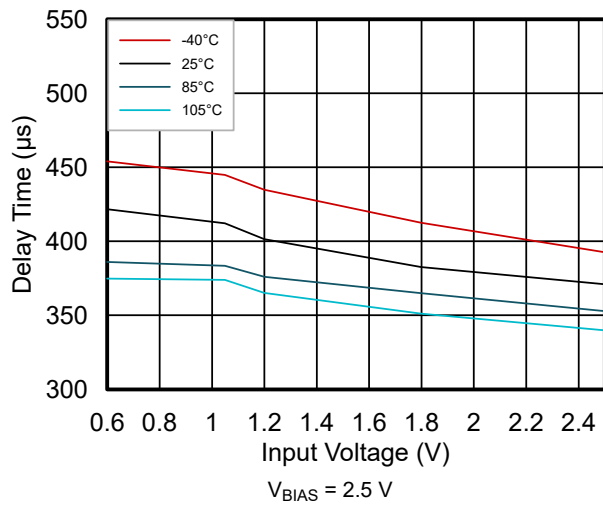

Figure 6-5. Delay Time vs Input Voltage

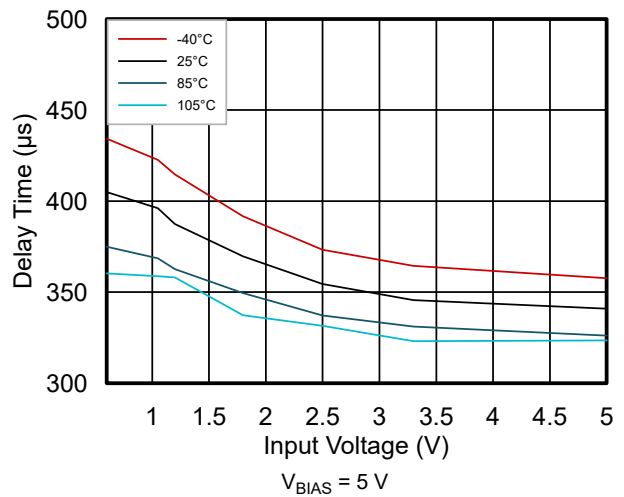

Figure 6-6. Delay Time vs Input Voltage

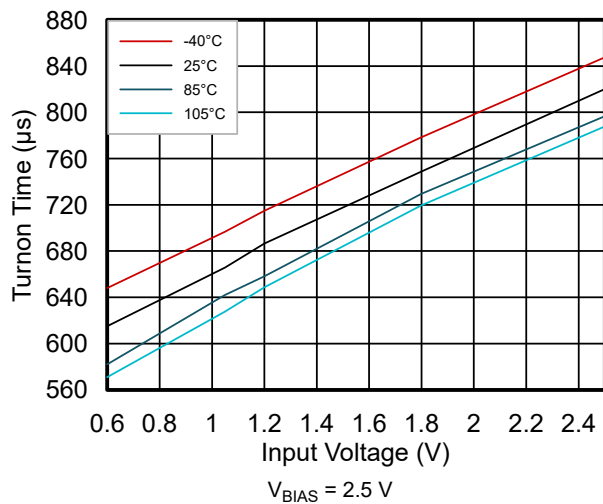

Figure 6-7. Turnon Time vs Input Voltage

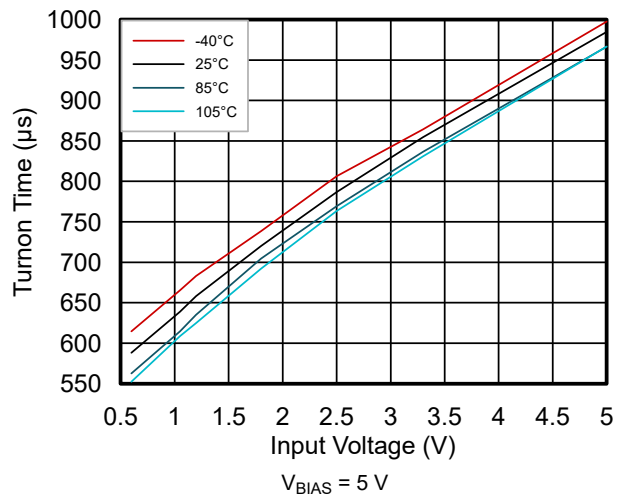

Figure 6-8. Turnon Time vs Input Voltage

6.8 Typical Characteristics: AC (continued)

$C_{IN} = 1 \mu\text{F}$, $C_L = 0.1 \mu\text{F}$, $R_L = 10 \Omega$, $V_{ON} = 5 \text{ V}$, $I_{ON} = 100 \mu\text{A}$ unless otherwise noticed

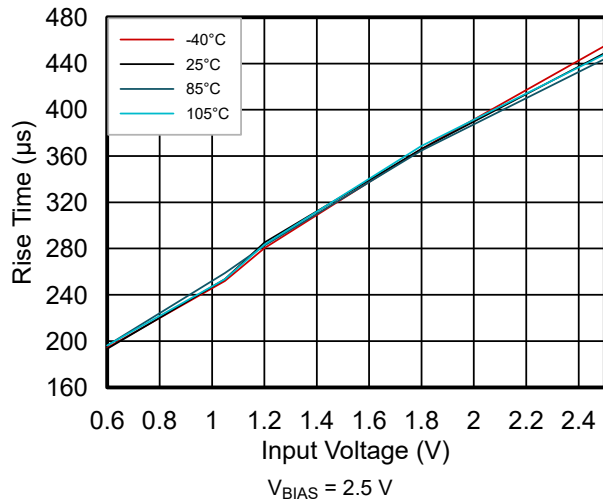

Figure 6-9. Rise Time vs Input Voltage

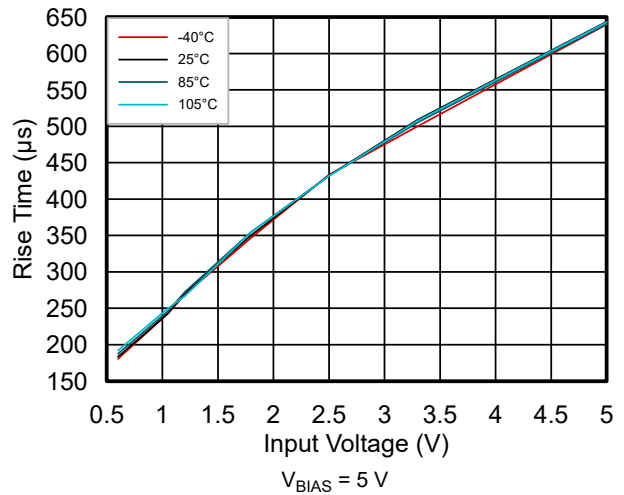

Figure 6-10. Rise Time vs Input Voltage

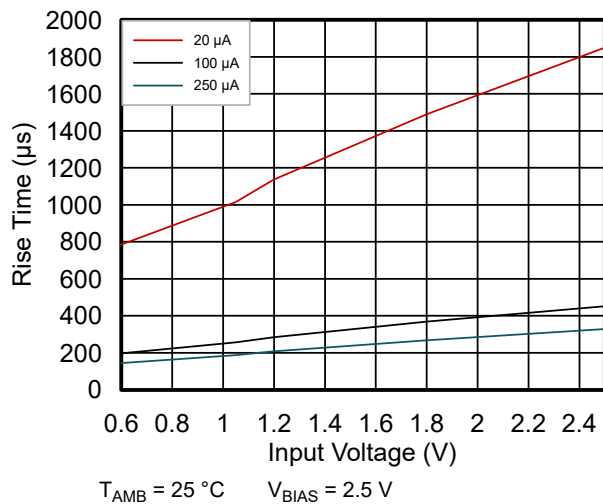

Figure 6-11. Rise Time vs Input Voltage with Different I_{ON}

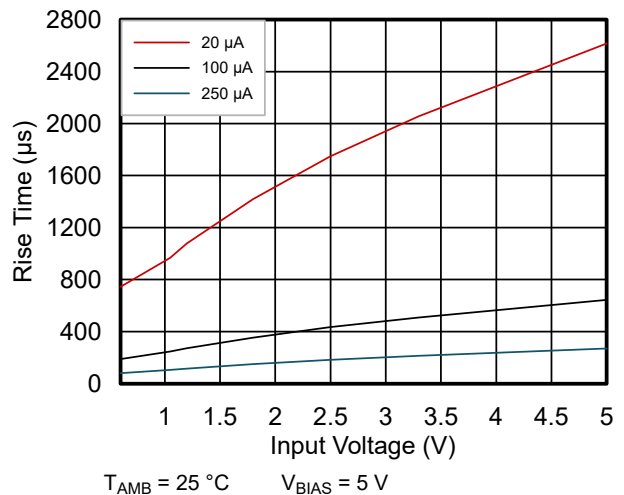

Figure 6-12. Rise Time vs Input Voltage with Different I_{ON}

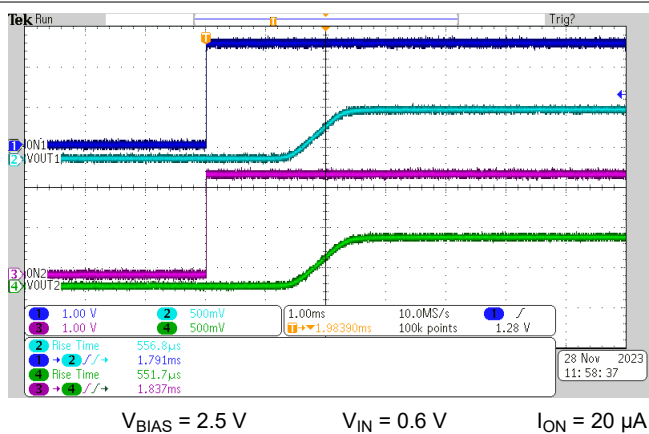

Figure 6-13. Turnon Response Time

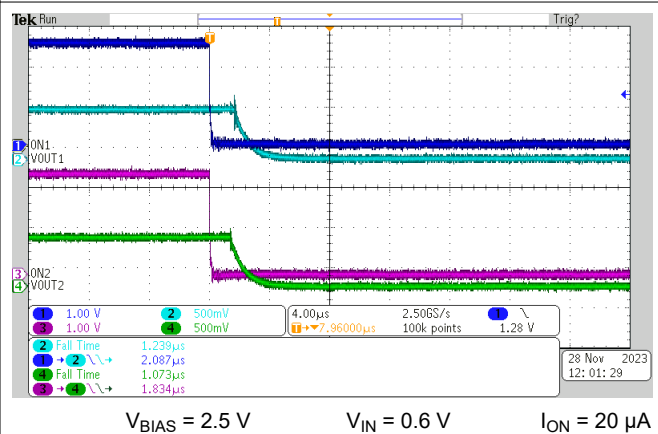

Figure 6-14. Turnoff Response Time

6.8 Typical Characteristics: AC (continued)

$C_{IN} = 1 \mu\text{F}$, $C_L = 0.1 \mu\text{F}$, $R_L = 10 \Omega$, $V_{ON} = 5 \text{ V}$, $I_{ON} = 100 \mu\text{A}$ unless otherwise noticed

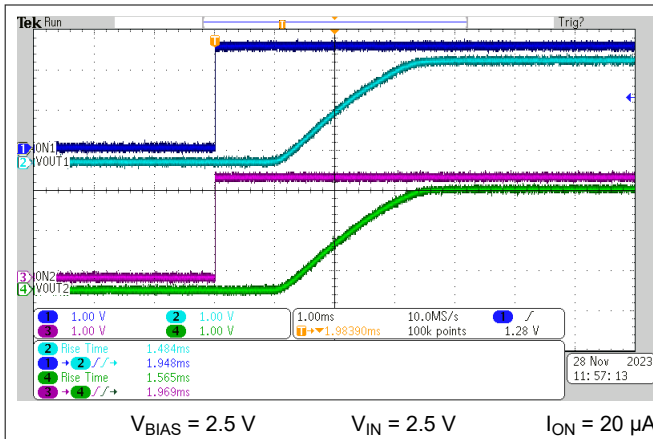

Figure 6-15. Turnon Response Time

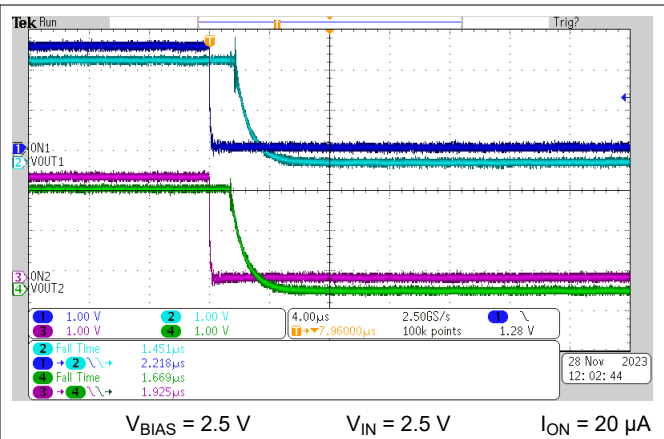

Figure 6-16. Turnoff Response Time

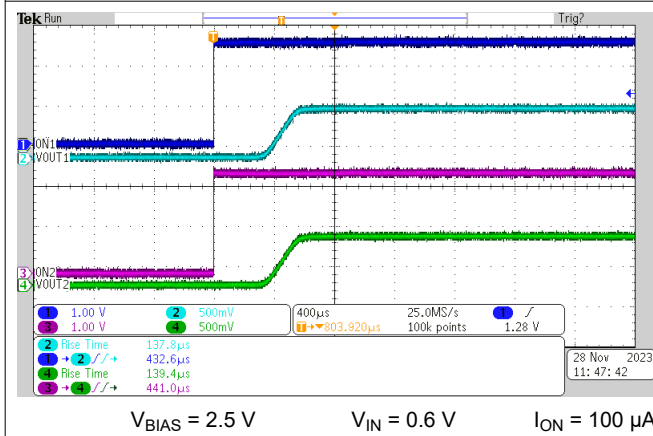

Figure 6-17. Turnon Response Time

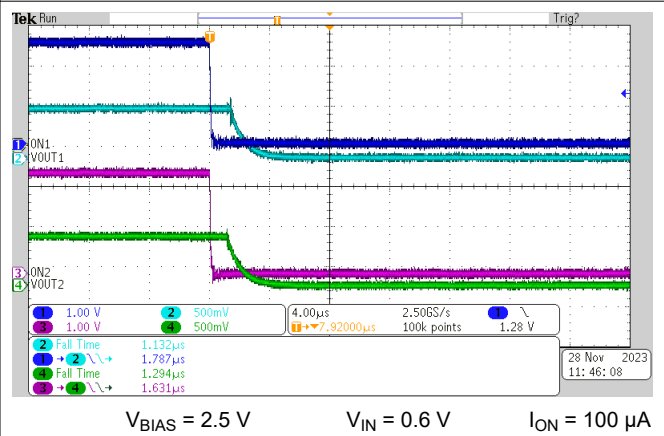

Figure 6-18. Turnoff Response Time

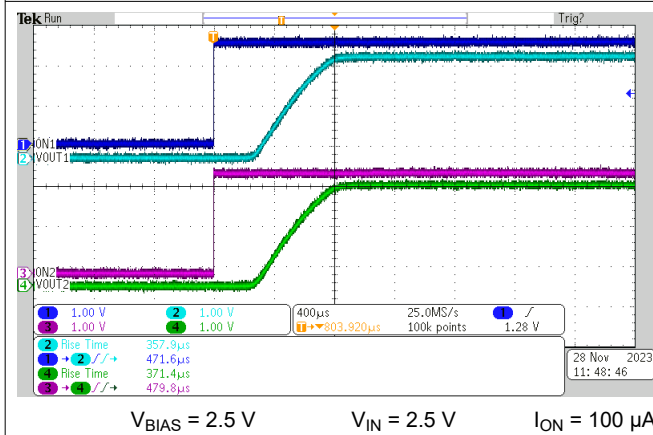

Figure 6-19. Turnon Response Time

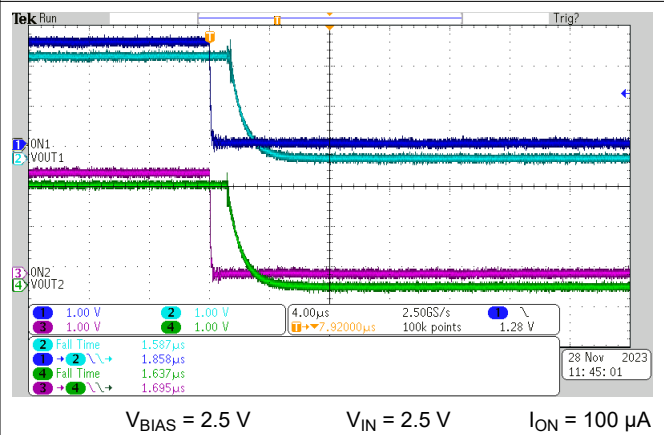
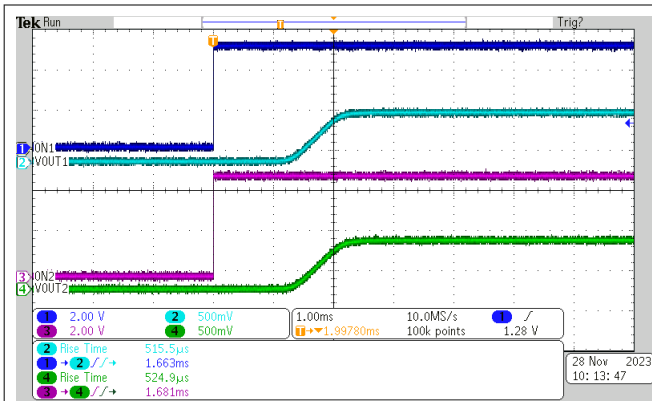

Figure 6-20. Turnoff Response Time

6.8 Typical Characteristics: AC (continued)

$C_{IN} = 1 \mu\text{F}$, $C_L = 0.1 \mu\text{F}$, $R_L = 10 \Omega$, $V_{ON} = 5 \text{ V}$, $I_{ON} = 100 \mu\text{A}$ unless otherwise noticed



$V_{BIAS} = 5 \text{ V}$ $V_{IN} = 0.6 \text{ V}$ $I_{ON} = 20 \mu\text{A}$

Figure 6-21. Turnon Response Time

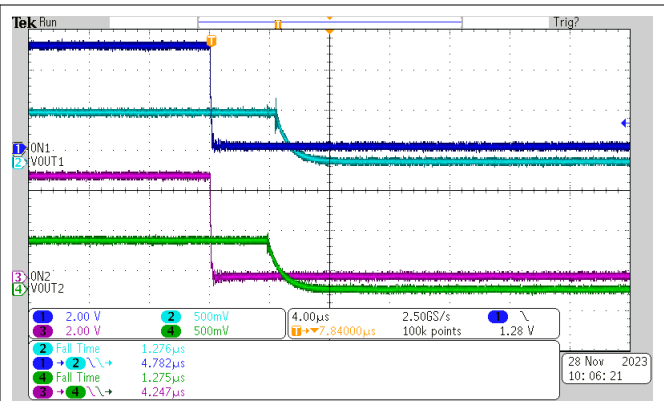

$V_{BIAS} = 5 \text{ V}$ $V_{IN} = 0.6 \text{ V}$ $I_{ON} = 20 \mu\text{A}$

Figure 6-22. Turnoff Response Time

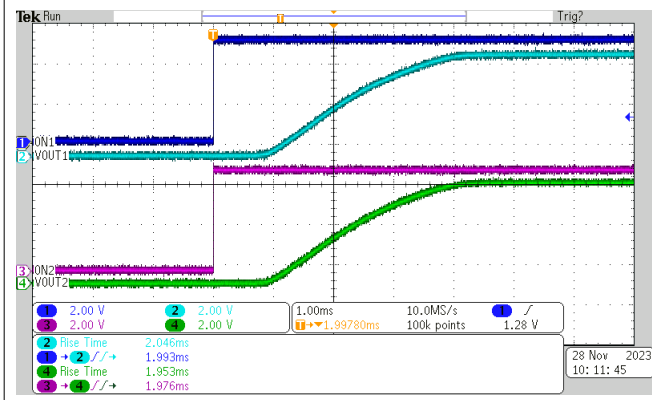

$V_{BIAS} = 5 \text{ V}$ $V_{IN} = 5 \text{ V}$ $I_{ON} = 20 \mu\text{A}$

Figure 6-23. Turnon Response Time

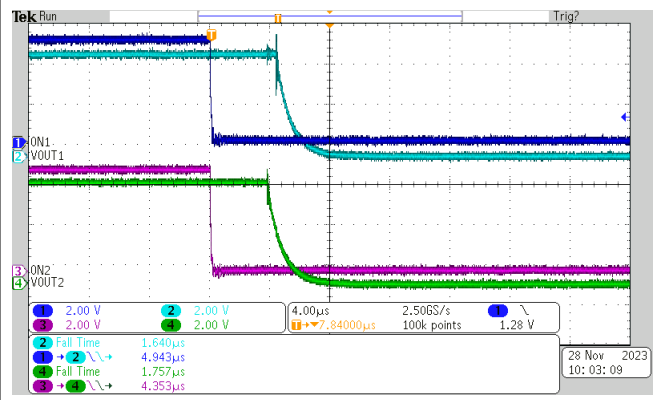

$V_{BIAS} = 5 \text{ V}$ $V_{IN} = 5 \text{ V}$ $I_{ON} = 20 \mu\text{A}$

Figure 6-24. Turnoff Response Time

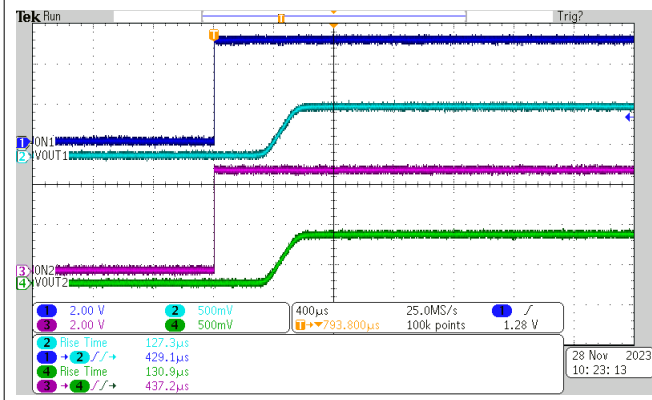

6.8 Typical Characteristics: AC (continued)

$C_{IN} = 1 \mu\text{F}$, $C_L = 0.1 \mu\text{F}$, $R_L = 10 \Omega$, $V_{ON} = 5 \text{ V}$, $I_{ON} = 100 \mu\text{A}$ unless otherwise noticed

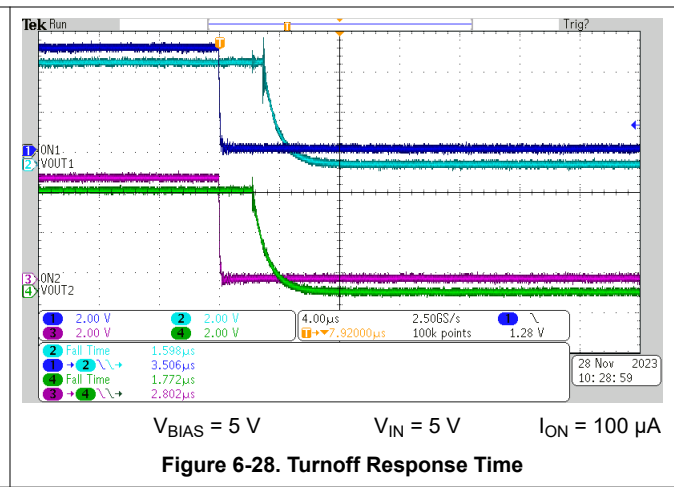
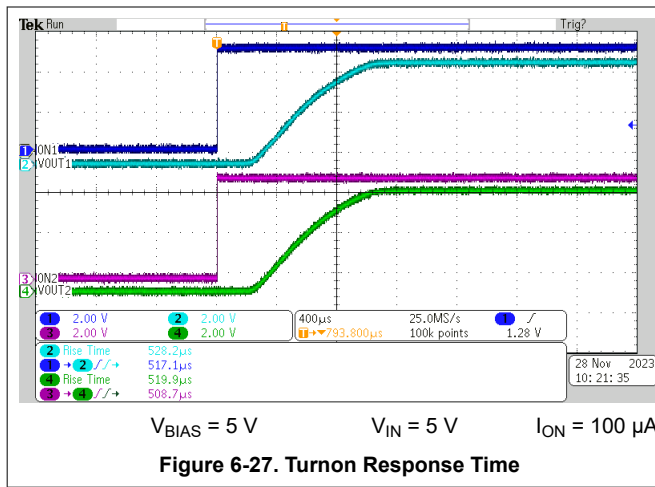

7 Parameter Measurement Information

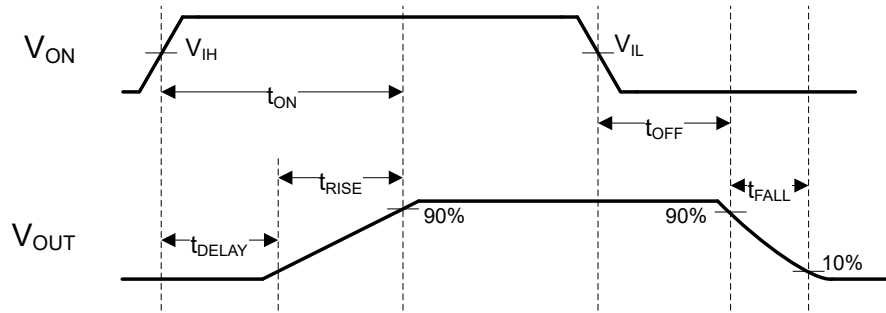

Figure 7-1. t_{ON} and t_{OFF} Waveforms

8 Detailed Description

8.1 Overview

The TPS22996 is a 5.5-V, dual-channel, 14-m Ω (typical) R_{ON} load switch in a 8-pin DRL package. Each channel can support a maximum continuous current of 4 A and is controlled by an on and off GPIO-compatible input. To reduce the voltage drop in high current rails, the device implements N-channel MOSFETs. Note that the ON pins must be connected and cannot be left floating. The device has a configurable slew rate for applications that require specific rise-time, which controls the inrush current. By controlling the inrush current, power supply sag can be reduced during turnon. Furthermore, the slew rate is proportional to the series resistor used on the ONx pin. See [Section 8.3.6](#) to determine the correct resistor value for a desired rise time.

The internal circuitry is powered by the V_{BIAS} pin, which supports voltages from 2.5 V to 5.5 V. This circuitry includes the charge pump, QOD (optional), and control logic. When a voltage is applied to V_{BIAS} , and the ONx pins transition to a low state, the QOD functionality is activated. This connects V_{OUTX} to ground through the on-chip resistor. The typical pulldown resistance (R_{PD}) is 230 Ω .

During the off state, the device prevents downstream circuits from pulling high standby current from the supply. The integrated control logic, driver, power supply, and output discharge FET eliminates the need for any external components, reducing solution size and bill of materials (BOM) count.

8.2 Functional Block Diagram

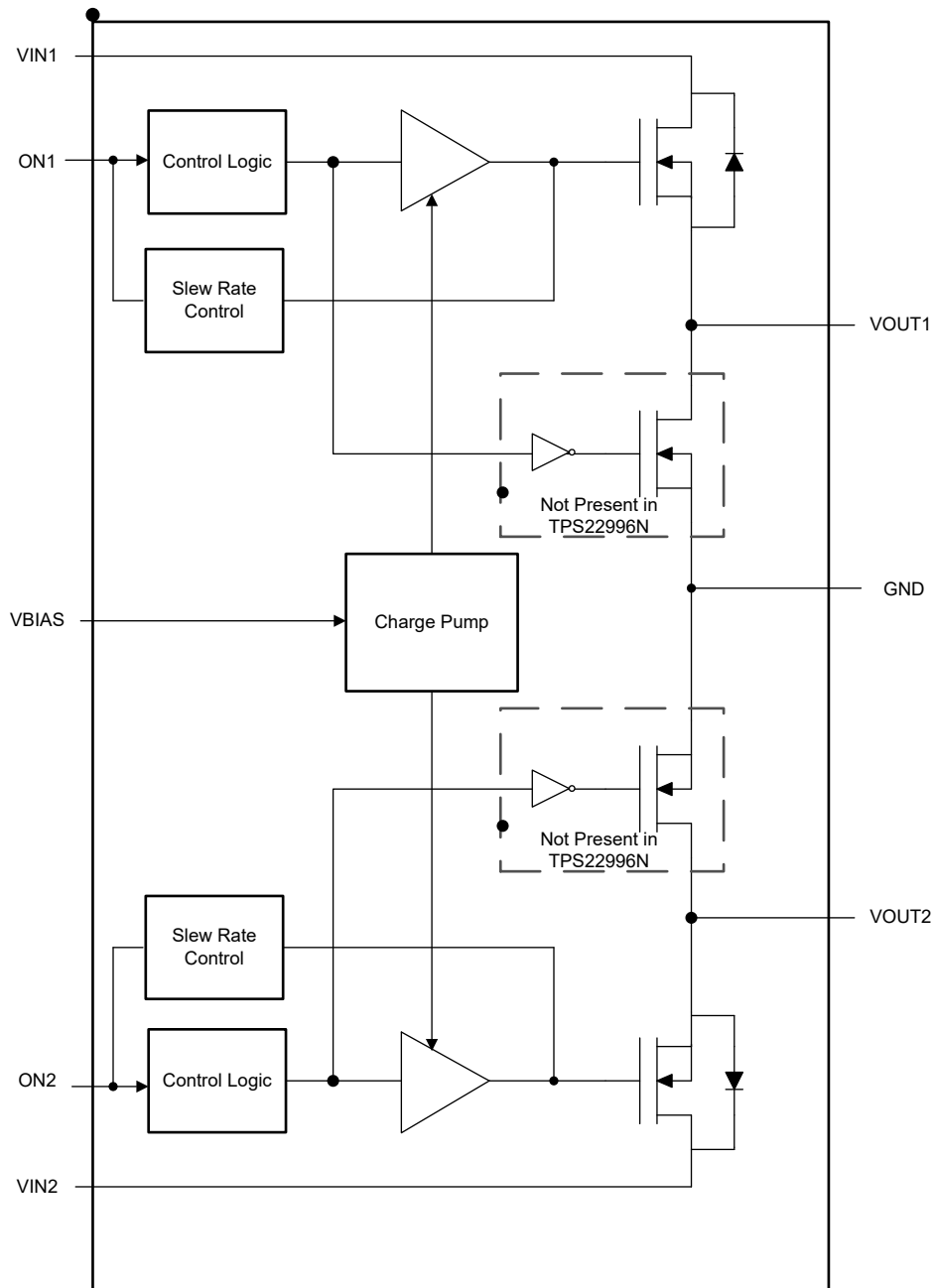

8.3 Feature Description

8.3.1 ON and OFF Control

The ON pins control the state of the switch and also the rise time of the output. Asserting ON high enables the switch. ON is active high with a low threshold, making it capable of interfacing with low-voltage signals. The ON pin is compatible with standard GPIO logic threshold. It can be used with any microcontroller with 1.2 V or higher GPIO voltage. This pin cannot be left floating and must be tied either high or low for proper functionality.

8.3.2 Input Capacitor (Optional)

To limit the voltage drop on the input supply caused by transient inrush currents when the switch turns on into a discharged load capacitor, a capacitor needs to be placed between VIN and GND. A 1- μ F ceramic capacitor,

C_{IN} , placed close to the pins is usually sufficient. Higher values of C_{IN} can be used to further reduce the voltage drop during high-current application. When switching heavy loads, it is recommended to have an input capacitor about 10 times higher than the output capacitor to avoid excessive voltage drop.

8.3.3 Output Capacitor (Optional)

Due to the integrated body diode in the NMOS switch, a C_{IN} greater than C_L is highly recommended. A C_L greater than C_{IN} can cause V_{OUT} to exceed V_{IN} when the system supply is removed. This could result in current flow through the body diode from V_{OUT} to V_{IN} . A C_{IN} to C_L ratio of 10 to 1 is recommended for minimizing V_{IN} dip caused by inrush currents during startup, however a 10 to 1 ratio for capacitance is not required for proper functionality of the device. A ratio smaller than 10 to 1 (such as 1 to 1) could cause slightly more V_{IN} dip upon turnon due to inrush currents. This can be mitigated by increasing the capacitance on the RT resistor for a longer rise time (see [Section 8.3.6](#)).

8.3.4 Quick Output Discharge (QOD)

The TPS22996 includes a QOD feature. When the switch V_{ONX} is disabled, an internal discharge resistance is connected between V_{OUTX} and GND to remove the remaining charge from the output. This resistance prevents the output from floating while the switch is disabled. For best results, it is recommended that the device gets disabled before V_{BIAS} falls below the minimum recommended voltage.

8.3.5 Thermal Shutdown

Thermal Shutdown protects the part from internally or externally generated excessive temperatures. When the device temperature exceeds T_{SD} , the switch is turned off. The switch automatically turns on again if the temperature of the die drops below hysteresis.

8.3.6 Adjustable Rise Time

TPS22996 integrates a unique architecture for adjusting the rise time. The device senses the current flowing into the ON1 and ON2 (I_{ON}) pins and utilizes the information to set the rise time. This allows the user to adjust the rise time by connecting a series resistance that is determined by the ON Pin voltage. Refer to [Table 8-1](#) and [Table 8-2](#) for reference on setting the resistor.

Table 8-1. Typical Rise Time ($V_{BIAS} = 5.0\text{ V}$, $R_L = 10\ \Omega$, $C_L = 0.1\ \mu\text{F}$)

| I_{ON} | $V_{IN} = 0.6\text{ V}$ | $V_{IN} = 1.8\text{ V}$ | $V_{IN} = 2.5\text{ V}$ | $V_{IN} = 3.3\text{ V}$ | $V_{IN} = 5.0\text{ V}$ |
|-------------------|-------------------------|-------------------------|-------------------------|-------------------------|-------------------------|
| 20 μA | 810 μs | 1434 μs | 1760 μs | 1986 μs | 2580 μs |
| 100 μA | 215 μs | 364 μs | 445 μs | 519 μs | 688 μs |
| 250 μA | 90 μs | 151 μs | 185 μs | 220 μs | 291 μs |

Table 8-2. Typical Rise Time ($V_{BIAS} = 3.3\text{ V}$, $R_L = 10\ \Omega$, $C_L = 0.1\ \mu\text{F}$)

| I_{ON} | $V_{IN} = 0.6\text{ V}$ | $V_{IN} = 1.8\text{ V}$ | $V_{IN} = 2.5\text{ V}$ | $V_{IN} = 3.3\text{ V}$ |
|-------------------|-------------------------|-------------------------|-------------------------|-------------------------|
| 20 μA | 781 μs | 1489 μs | 1821 μs | 2154 μs |
| 100 μA | 200 μs | 374 μs | 451 μs | 536 μs |
| 250 μA | 93 μs | 175 μs | 207 μs | 244 μs |

The following equation can be used to estimate the series resistance required to meet the desired rise time.

$$R_T = 1000 \times (V_{ON} - 1.2\text{ V}) / I_{ON} - R_i \quad (1)$$

where:

- R_T = Series resistance in $k\Omega$.
- R_i = Internal On Pin resistance in $k\Omega$.
- V_{ON} = ON pin voltage in V.
- I_{ON} = Current flowing into the ON pin in μA .

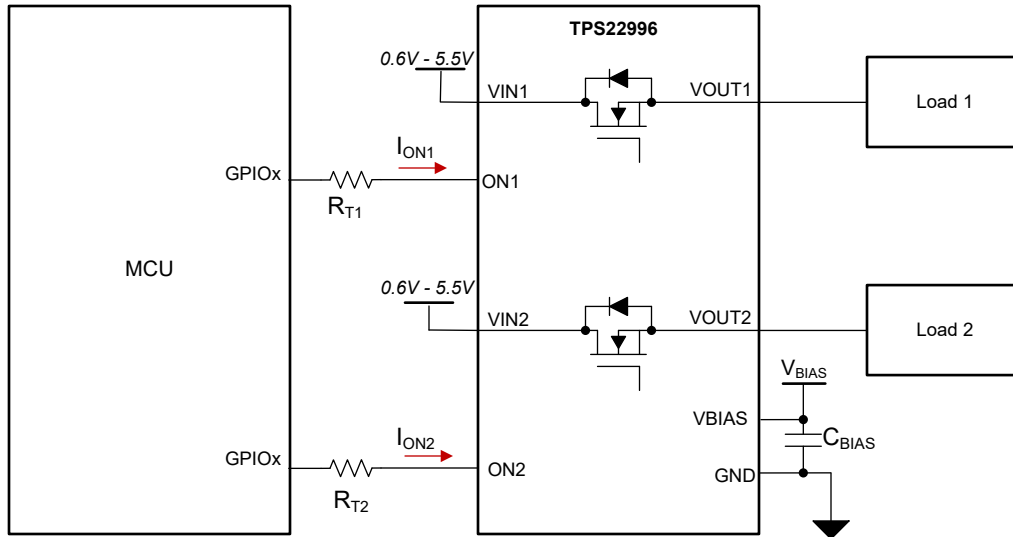

Figure 8-1. TPS22996 Adjustable Rise Time Configuration

8.4 Device Functional Modes

Table 8-3 lists the TPS22996 functions.

Table 8-3. TPS22996 Functions Table

| ON | VIN to VOUT | VOUT |
|----|-------------|------|
| L | Off | GND |
| H | On | VIN |

Table 8-4 lists the TPS22996N functions.

Table 8-4. TPS22996N Functions Table

| ON | VIN to VOUT | VOUT |
|----|-------------|----------|
| L | Off | Floating |
| H | On | VIN |

9 Application and Implementation

Note

Information in the following applications sections is not part of the TI component specification, and TI does not warrant its accuracy or completeness. TI's customers are responsible for determining suitability of components for their purposes, as well as validating and testing their design implementation to confirm system functionality.

9.1 Application Information

This section highlights some of the design considerations for implementing the device in various applications.

9.2 Typical Application

This application demonstrates how the TPS22996 can be used to limit the inrush current when powering on downstream modules.

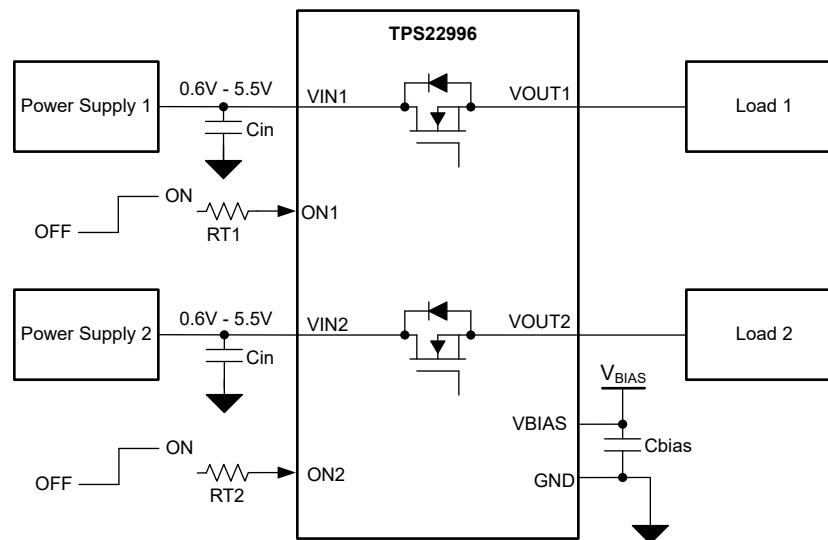

Figure 9-1. Typical Application Circuit

Table 9-1. Component Descriptions

| DESIGN PARAMETER | TYPICAL VALUES | DESCRIPTION |
|------------------|----------------|---|
| C_{IN} | 1 μ F | Filtering voltage transients |
| C_{OUT} | 100 nF | Filtering voltage transients |
| C_{BIAS} | 0.1 μ F | Filtering voltage transients and noises |
| RT1, RT2 | 10 k Ω | Series resistor for rise time control |

9.2.1 Design Requirements

For this example, the values below are used as the design parameters.

Table 9-2. Design Parameters

| PARAMETER | VALUE |
|------------|--------------|
| V_{BIAS} | 5 V |
| V_{IN} | 5 V |
| Rise Time | 1000 μ s |

9.2.2 Detailed Design Procedure

The design in this example is trying to achieve 1000 μs rise time for power sequencing, with both V_{BIAS} and V_{IN} to be 5 V. From [Table 8-1](#), the I_{ON} needs to be between 20 μA and 100 μA . To find the I_{ON} needed to achieve 1000 μs rise time, linear interpolation can be used to estimate as below:

$$T_{\text{R}} = (T_{\text{R}2} - T_{\text{R}1}) / (I_{\text{ON}2} - I_{\text{ON}1}) * (I_{\text{ON}} - I_{\text{ON}1}) + T_{\text{R}1} \quad (2)$$

where:

- T_{R} is the desired T_{R} , which is 1000 μs
- I_{ON} is the desired I_{ON}
- $T_{\text{R}1}$ is the first T_{R} used for linear interpolation, which is 2580 μs
- $T_{\text{R}2}$ is the second T_{R} used for linear interpolation, which is 688 μs
- $I_{\text{ON}1}$ is the first I_{ON} used for linear interpolation, which is 20 μA
- $I_{\text{ON}2}$ is the second I_{ON} used for linear interpolation, which is 100 μA

I_{ON} is calculated to be 86.8 μA . To find the R_{T} value, plug in the parameters in [Equation 1](#).

$$R_{\text{T}} = 1000 \times (5 \text{ V} - 1.2 \text{ V}) / 86.8 \mu\text{A} - 11.5 \text{ k}\Omega = 32.2 \text{ k}\Omega$$

By using the standard resistor value closest to 32.2 k Ω , the typical rise time can be calculated for the actual resistor value used on board.

9.3 Power Supply Recommendations

The device is designed to operate from a V_{BIAS} range of 2.5 V to 5.7 V and a V_{IN} range of 0.6 V to V_{BIAS} .

9.4 Layout

9.4.1 Layout Guidelines

For best performance, all traces must be as short as possible. To be most effective, the input and output capacitors must be placed close to the device to minimize the effects that parasitic trace inductances may have on normal operation. Using wide traces for V_{IN} , V_{OUT} , and GND helps minimize the parasitic electrical effects along with minimizing the case to ambient thermal impedance.

9.4.2 Layout Example

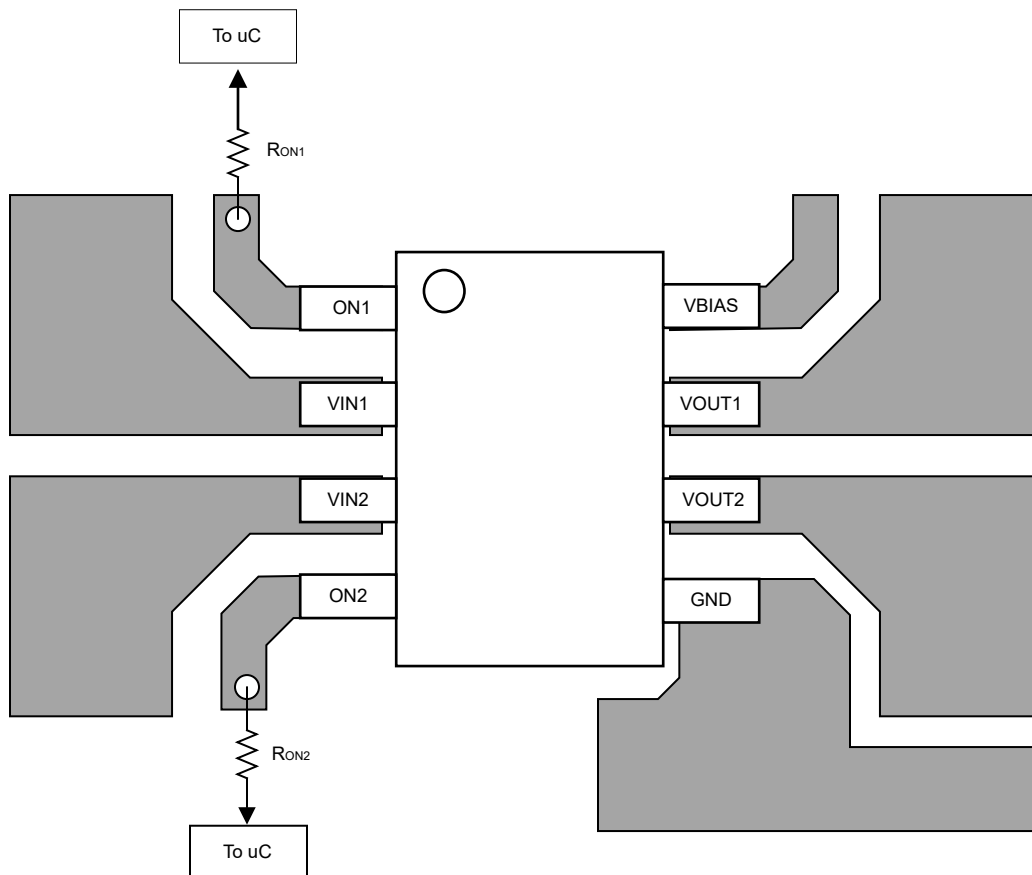

Figure 9-2. TPS22996 Layout Example

9.4.3 Power Dissipation

The maximum IC junction temperature must be restricted to 125°C under normal operating conditions. To calculate the maximum allowable power dissipation, $P_{D(max)}$ for a given output current and ambient temperature, use Equation 3.

$$P_{D(max)} = \frac{T_{J(max)} - T_A}{\theta_{JA}} \quad (3)$$

where

- $P_{D(max)}$ is the maximum allowable power dissipation.
- $T_{J(max)}$ is the maximum allowable junction temperature (125°C for the TPS22996).

- T_A is the ambient temperature of the device.
- θ_{JA} is the junction to air thermal impedance. See the [Thermal Information](#) section. This parameter is highly dependent upon board layout.

10 Device and Documentation Support

10.1 Documentation Support

10.1.1 Related Documentation

10.2 Receiving Notification of Documentation Updates

To receive notification of documentation updates, navigate to the device product folder on [ti.com](https://www.ti.com). Click on *Notifications* to register and receive a weekly digest of any product information that has changed. For change details, review the revision history included in any revised document.

10.3 Support Resources

[TI E2E™ support forums](#) are an engineer's go-to source for fast, verified answers and design help — straight from the experts. Search existing answers or ask your own question to get the quick design help you need.

Linked content is provided "AS IS" by the respective contributors. They do not constitute TI specifications and do not necessarily reflect TI's views; see TI's [Terms of Use](#).

10.4 Trademarks

TI E2E™ is a trademark of Texas Instruments.
All trademarks are the property of their respective owners.

10.5 Electrostatic Discharge Caution



This integrated circuit can be damaged by ESD. Texas Instruments recommends that all integrated circuits be handled with appropriate precautions. Failure to observe proper handling and installation procedures can cause damage.

ESD damage can range from subtle performance degradation to complete device failure. Precision integrated circuits may be more susceptible to damage because very small parametric changes could cause the device not to meet its published specifications.

10.6 Glossary

[TI Glossary](#) This glossary lists and explains terms, acronyms, and definitions.

11 Revision History

NOTE: Page numbers for previous revisions may differ from page numbers in the current version.

| DATE | REVISION | NOTES |
|---------------|----------|-----------------|
| December 2023 | * | Initial Release |

12 Mechanical, Packaging, and Orderable Information

The following pages include mechanical, packaging, and orderable information. This information is the most-current data available for the designated devices. This data is subject to change without notice and without revision of this document. For browser-based versions of this data sheet, see the left-hand navigation pane.

PACKAGING INFORMATION

| Orderable Device | Status (1) | Package Type | Package Drawing | Pins | Package Qty | Eco Plan (2) | Lead finish/ Ball material (6) | MSL Peak Temp (3) | Op Temp (°C) | Device Marking (4/5) | Samples |
|------------------|---------------|--------------|-----------------|------|-------------|-----------------|--------------------------------------|----------------------|--------------|-------------------------|---------|
| TPS22996DRLR | ACTIVE | SOT-5X3 | DRL | 8 | 4000 | RoHS & Green | Call TI SN | Level-1-260C-UNLIM | -40 to 105 | 22996 | Samples |

(1) The marketing status values are defined as follows:

ACTIVE: Product device recommended for new designs.

LIFEBUY: TI has announced that the device will be discontinued, and a lifetime-buy period is in effect.

NRND: Not recommended for new designs. Device is in production to support existing customers, but TI does not recommend using this part in a new design.

PREVIEW: Device has been announced but is not in production. Samples may or may not be available.

OBSELETE: TI has discontinued the production of the device.

(2) **RoHS:** TI defines "RoHS" to mean semiconductor products that are compliant with the current EU RoHS requirements for all 10 RoHS substances, including the requirement that RoHS substance do not exceed 0.1% by weight in homogeneous materials. Where designed to be soldered at high temperatures, "RoHS" products are suitable for use in specified lead-free processes. TI may reference these types of products as "Pb-Free".

RoHS Exempt: TI defines "RoHS Exempt" to mean products that contain lead but are compliant with EU RoHS pursuant to a specific EU RoHS exemption.

Green: TI defines "Green" to mean the content of Chlorine (Cl) and Bromine (Br) based flame retardants meet JS709B low halogen requirements of <=1000ppm threshold. Antimony trioxide based flame retardants must also meet the <=1000ppm threshold requirement.

(3) MSL, Peak Temp. - The Moisture Sensitivity Level rating according to the JEDEC industry standard classifications, and peak solder temperature.

(4) There may be additional marking, which relates to the logo, the lot trace code information, or the environmental category on the device.

(5) Multiple Device Markings will be inside parentheses. Only one Device Marking contained in parentheses and separated by a "-" will appear on a device. If a line is indented then it is a continuation of the previous line and the two combined represent the entire Device Marking for that device.

(6) Lead finish/Ball material - Orderable Devices may have multiple material finish options. Finish options are separated by a vertical ruled line. Lead finish/Ball material values may wrap to two lines if the finish value exceeds the maximum column width.

Important Information and Disclaimer:The information provided on this page represents TI's knowledge and belief as of the date that it is provided. TI bases its knowledge and belief on information provided by third parties, and makes no representation or warranty as to the accuracy of such information. Efforts are underway to better integrate information from third parties. TI has taken and continues to take reasonable steps to provide representative and accurate information but may not have conducted destructive testing or chemical analysis on incoming materials and chemicals. TI and TI suppliers consider certain information to be proprietary, and thus CAS numbers and other limited information may not be available for release.

In no event shall TI's liability arising out of such information exceed the total purchase price of the TI part(s) at issue in this document sold by TI to Customer on an annual basis.

EXAMPLE BOARD LAYOUT

DRL0008A

SOT-5X3 - 0.6 mm max height

PLASTIC SMALL OUTLINE

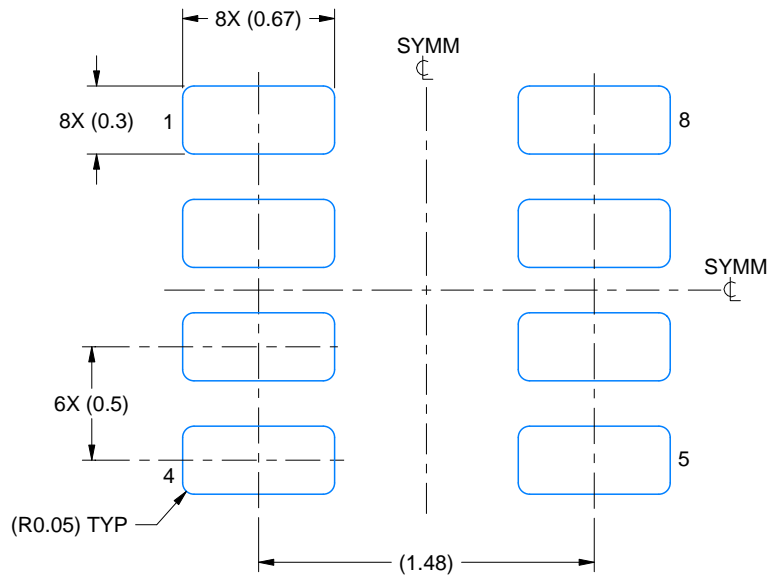

LAND PATTERN EXAMPLE
EXPOSED METAL SHOWN
SCALE:30X

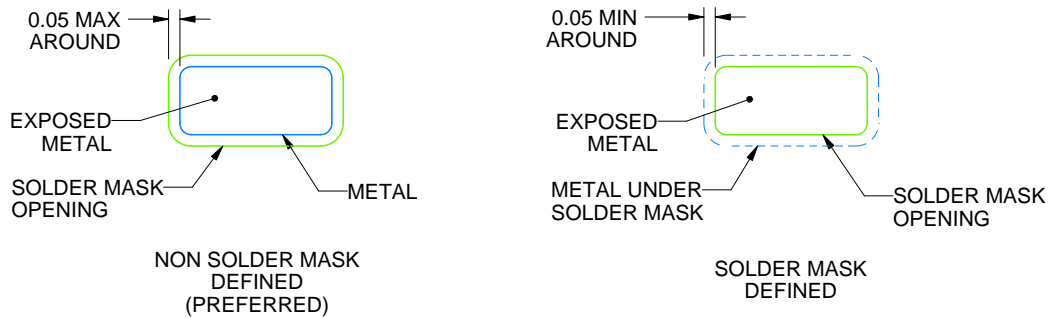

SOLDERMASK DETAILS

4224486/E 12/2021

NOTES: (continued)

- 5. Publication IPC-7351 may have alternate designs.
- 6. Solder mask tolerances between and around signal pads can vary based on board fabrication site.
- 7. Land pattern design aligns to IPC-610, Bottom Termination Component (BTC) solder joint inspection criteria.

EXAMPLE STENCIL DESIGN

DRL0008A

SOT-5X3 - 0.6 mm max height

PLASTIC SMALL OUTLINE

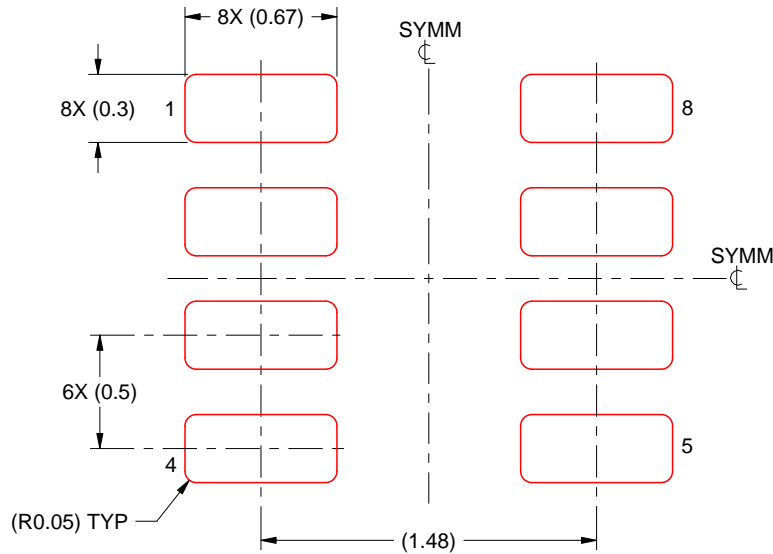

SOLDER PASTE EXAMPLE
BASED ON 0.1 mm THICK STENCIL
SCALE:30X

4224486/E 12/2021

NOTES: (continued)

8. Laser cutting apertures with trapezoidal walls and rounded corners may offer better paste release. IPC-7525 may have alternate design recommendations.
9. Board assembly site may have different recommendations for stencil design.

IMPORTANT NOTICE AND DISCLAIMER

TI PROVIDES TECHNICAL AND RELIABILITY DATA (INCLUDING DATA SHEETS), DESIGN RESOURCES (INCLUDING REFERENCE DESIGNS), APPLICATION OR OTHER DESIGN ADVICE, WEB TOOLS, SAFETY INFORMATION, AND OTHER RESOURCES "AS IS" AND WITH ALL FAULTS, AND DISCLAIMS ALL WARRANTIES, EXPRESS AND IMPLIED, INCLUDING WITHOUT LIMITATION ANY IMPLIED WARRANTIES OF MERCHANTABILITY, FITNESS FOR A PARTICULAR PURPOSE OR NON-INFRINGEMENT OF THIRD PARTY INTELLECTUAL PROPERTY RIGHTS.

These resources are intended for skilled developers designing with TI products. You are solely responsible for (1) selecting the appropriate TI products for your application, (2) designing, validating and testing your application, and (3) ensuring your application meets applicable standards, and any other safety, security, regulatory or other requirements.

These resources are subject to change without notice. TI grants you permission to use these resources only for development of an application that uses the TI products described in the resource. Other reproduction and display of these resources is prohibited. No license is granted to any other TI intellectual property right or to any third party intellectual property right. TI disclaims responsibility for, and you will fully indemnify TI and its representatives against, any claims, damages, costs, losses, and liabilities arising out of your use of these resources.

TI's products are provided subject to [TI's Terms of Sale](#) or other applicable terms available either on [ti.com](https://www.ti.com) or provided in conjunction with such TI products. TI's provision of these resources does not expand or otherwise alter TI's applicable warranties or warranty disclaimers for TI products.

TI objects to and rejects any additional or different terms you may have proposed.

Mailing Address: Texas Instruments, Post Office Box 655303, Dallas, Texas 75265
Copyright © 2024, Texas Instruments Incorporated