

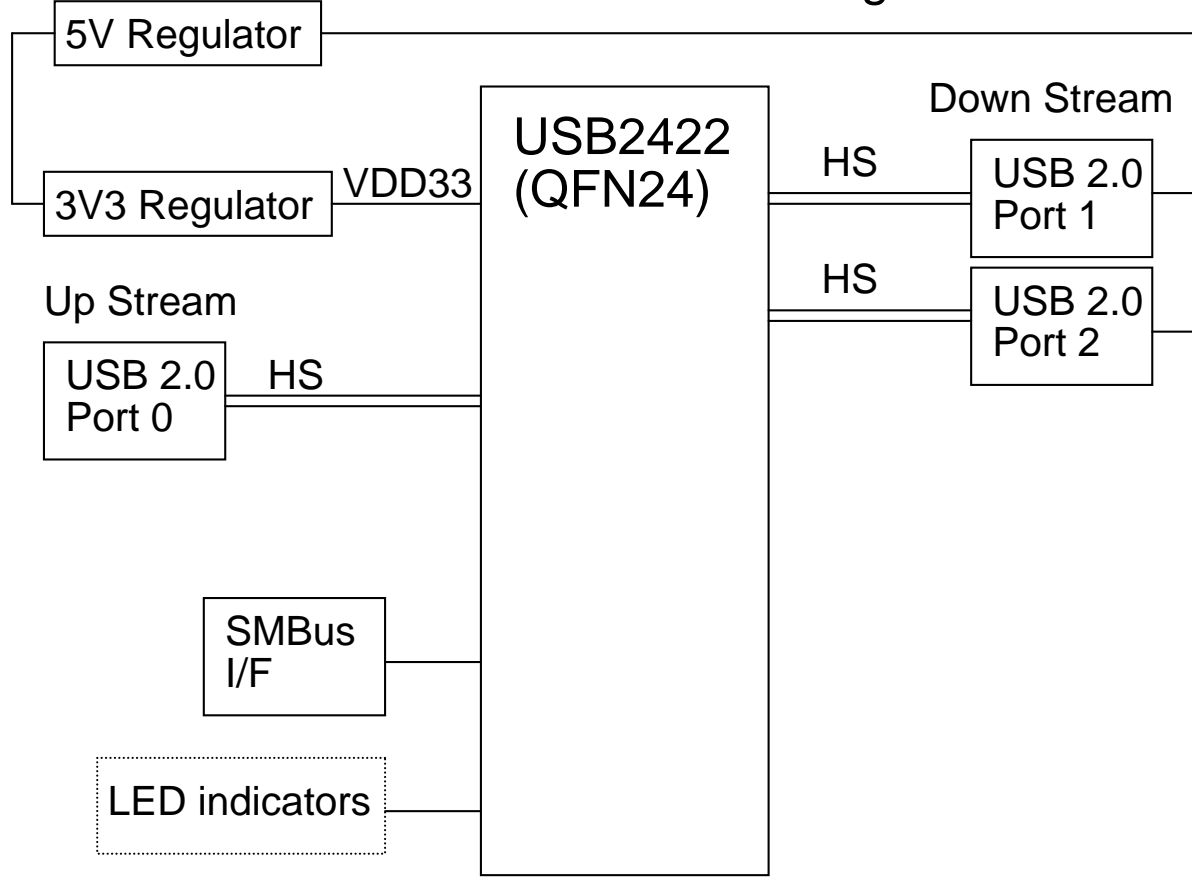

EVB-USB2422

Evaluation Board for USB2422

- Supports Self-power
- Optional SMBUS Configuration
- 2 Down Stream High Speed USB 2.0 ports
- Individual Port Power Control
- Crystal and Oscillator Inputs

Functional Block Diagram



 SMSC SUCCESS BY DESIGN		SMSC - Austin 10900-B Stonelake Blvd. Austin, TX 78759 512.502.0070	
		Title: Evaluation Board for USB2422, QFN24 Part Number: EVB-USB2422	
Size: B	Project Name: EVB-USB2422	Rev: A3	Date: Friday, June 07, 2013
		Sheet 1 of 2	

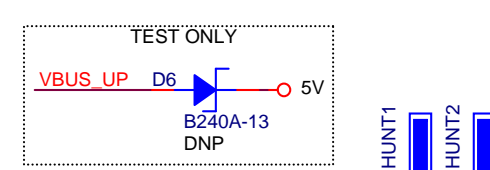
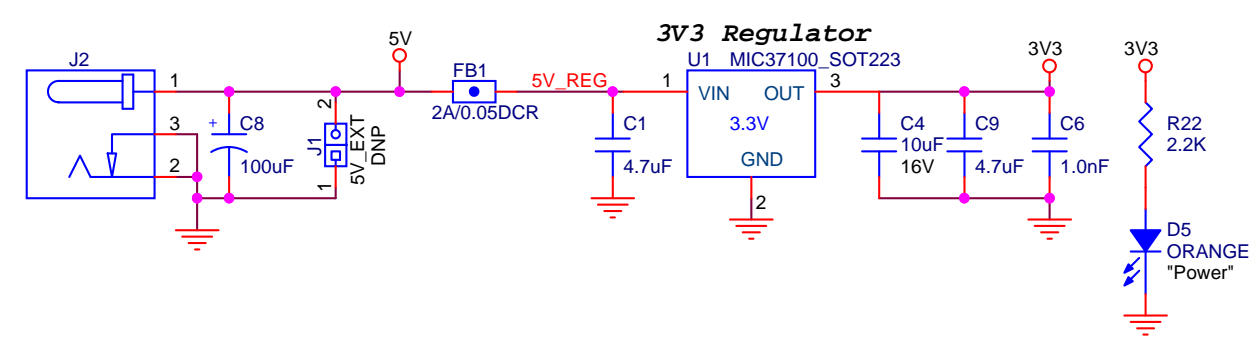
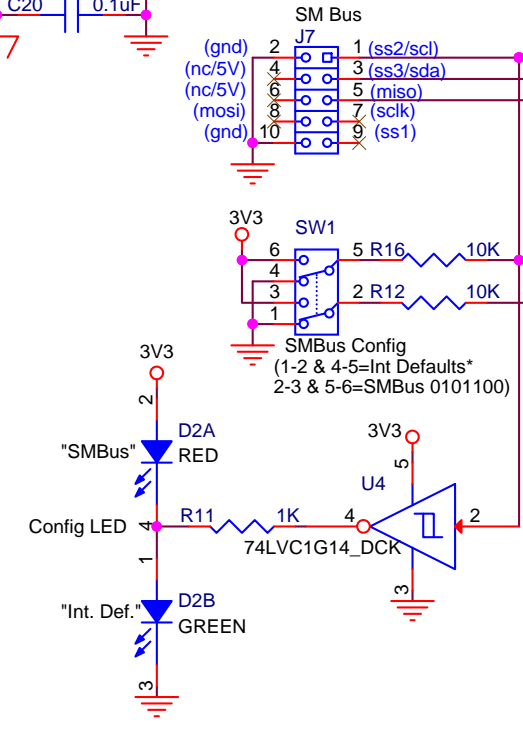
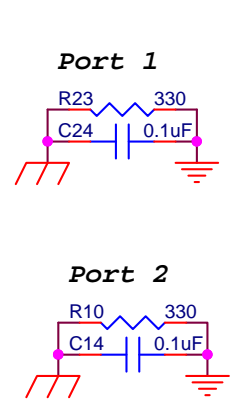
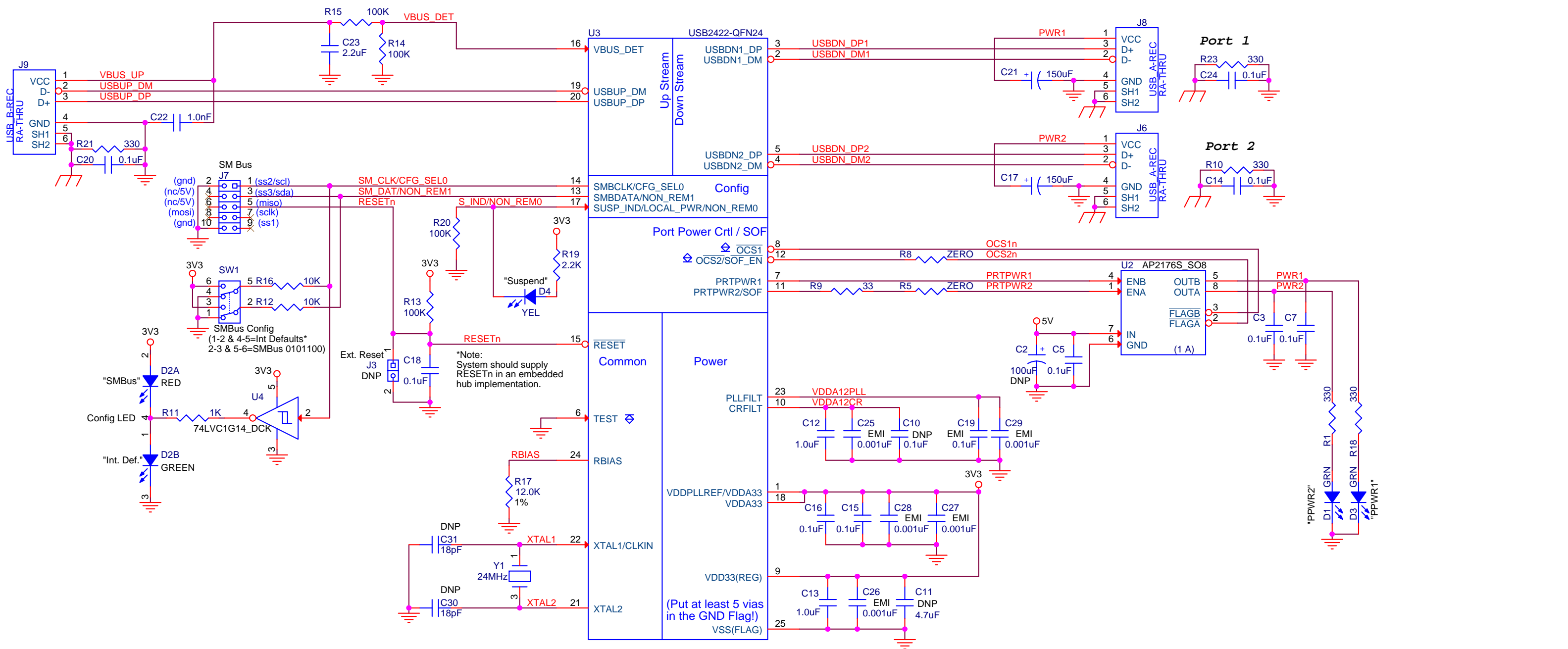

SMSC
 SUCCESS BY DESIGN

SMSC - Austin
 10900-B Stonelake Blvd.
 Austin, TX 78759
 512.502.0070

Title: Evaluation Board for USB2422, QFN24	
Part Number: EVB-USB2422	
Size: B	Project Name: EVB-USB2422
Date: Friday, June 07, 2013	Rev A3

Sheet 2 of 2