

# DK Board DC-DC Converter Design

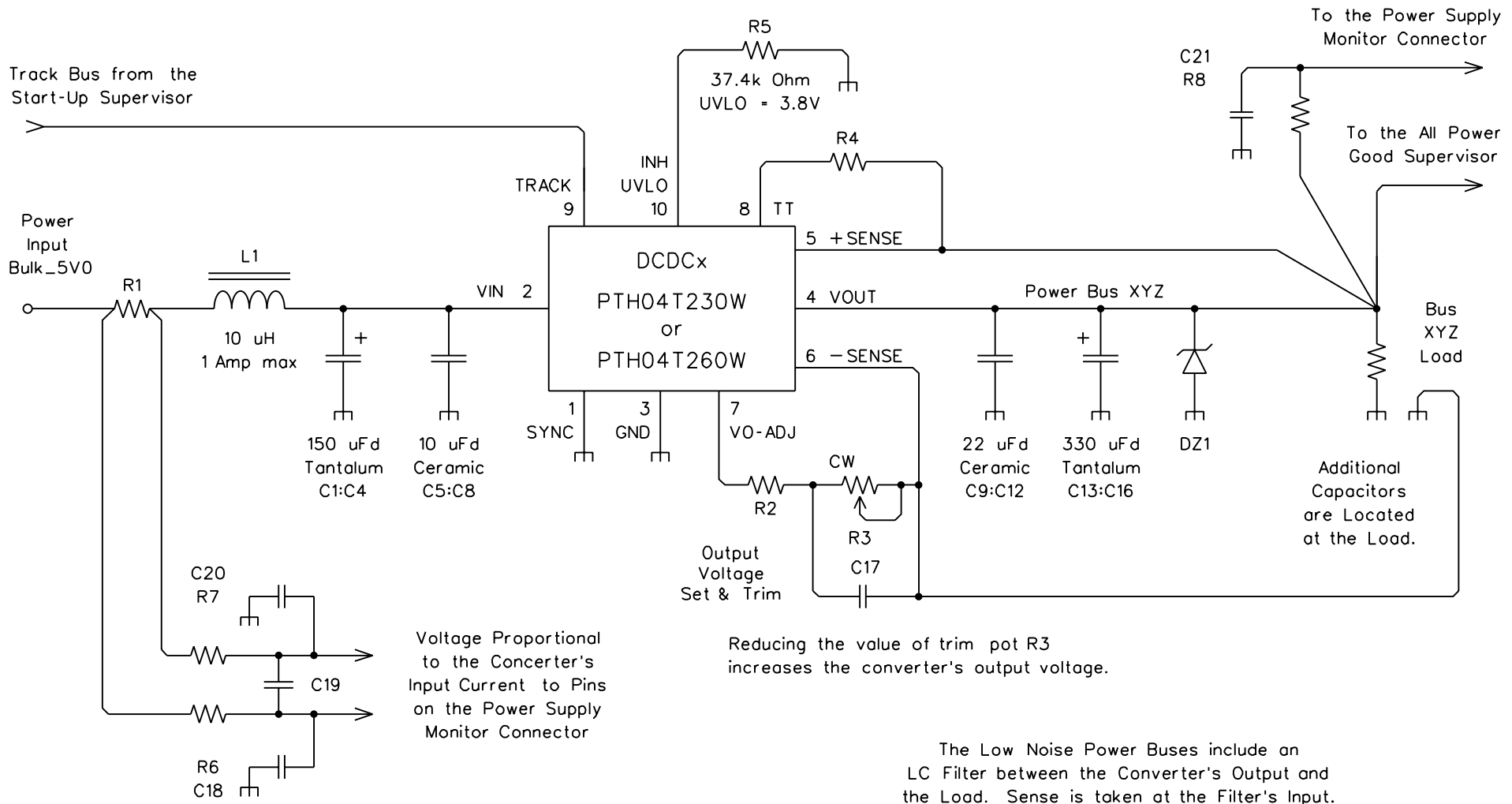

R1 is 5 to 30 mOhm depending on the DCDC Converter.

All 6 DCDC Converters are similar in design. Actual reference designators are larger by 1700. Reference designators increment by 30 from one converter to the next.

The RC Filters for the Power Supply Monitors:  
220 Ohm Resistors  
1 uFd Capacitors  
220 usec 723 Hz

DK Drw. 3  
Rev. 2-Jan-2024