



Libero® SoC v2022.3

PolarFire® SoC MSS Configurator User Guide

Introduction

The PolarFire® SoC Microcontroller Subsystem (MSS) Configurator provides a graphical user interface that allows embedded software engineers to define the MSS start-up state quickly. It exports an XML file that is consumed by the embedded software flow that converts the XML into initialization constructs. Additionally, the tool outputs a CXZ file for inclusion into your Libero® design flow. The CXZ file contains information about metadata and port needed by the FPGA designer to complete the MSS and FPGA fabric connectivity.

MSS configurator is available as a stand-alone application and as part of the Libero SoC design tool suite. The information in this user guide applies to both.



Important: Older versions of this documentation uses the terms "Master" and "Slave." The equivalent Microchip terminology used in this document is "Initiator" and "Target" respectively.

Table of Contents

Introduction.....	1
1. References.....	3
2. Installing the PolarFire SoC MSS Configurator.....	4
2.1. Input and Output Files.....	4
3. Running the PolarFire SoC MSS Configurator.....	5
3.1. Batch Mode.....	5
3.2. Interactive Mode.....	5
3.3. Using the PolarFire SoC MSS Configurator GUI.....	6
4. Creating a Project and Configuring MSS.....	37
5. Generating, Importing, and Exporting the MSS Component.....	39
5.1. Generating the MSS Component and Report.....	39
5.2. Importing the MSS CXZ File to Libero SoC.....	41
5.3. Importing the MSS XML File to SoftConsole.....	41
5.4. Exporting the FPGA Design Hardware Platform Information.....	41
6. Simulating an FPGA Design Interacting with MSS.....	42
7. Programming the Application Bitstream.....	43
8. Sample Project.....	44
9. Revision History.....	45
Microchip FPGA Support.....	47
Microchip Information.....	47
The Microchip Website.....	47
Product Change Notification Service.....	47
Customer Support.....	47
Microchip Devices Code Protection Feature.....	47
Legal Notice.....	48
Trademarks.....	48
Quality Management System.....	49
Worldwide Sales and Service.....	50

1. References

See the following reference documents for further details:

- Configuration of the MSS clocks.
 - For detailed information about the MSS clocking features, see [PolarFire FPGA and PolarFire SoC FPGA Clocking Resources User Guide](#).
- Configuration of the MSS interfaces to the FPGA fabric.
 - For detailed information about the MSS Fabric Interface Controller (FIC) features, see [PolarFire SoC FPGA MSS Technical Reference Manual](#).
- Selection and assignment of the MSS peripherals to the MSS dedicated I/Os and/or the FPGA fabric dedicated peripheral interfaces.
 - For detailed information about the MSS Peripherals features, see [PolarFire SoC FPGA MSS Technical Reference Manual](#).
- Configuration of the MSS Bank voltages and I/O standards and attributes.
 - For detailed information about the MSS Banks and I/Os features, see [PolarFire FPGA and PolarFire SoC FPGA User I/O User Guide](#).
- Configuration of the MSS DDR memories (DDR3/L, DDR4, LPDDR3, and LPDDR4).
 - For detailed information about the MSS DDR4, DDR3, LPDDR3, and LPDDR4 features, see [PolarFire FPGA and PolarFire SoC FPGA Memory Controller User Guide](#).
- Configuration of the MSS debug features.
 - For detailed information about the MSS debug features, see [PolarFire SoC FPGA MSS Technical Reference Manual](#).

2. Installing the PolarFire SoC MSS Configurator

The PolarFire SoC MSS Configurator bundled with Libero is available at the following location in the Libero installation section:

- Windows:
<Installation_Directory>\Microsemi\Libero_SoC_vX.X\Designer\bin64\pfsoc_mss.exe
- Linux: <Installation_Directory>\Microsemi\Libero_SoC_vX.X\bin64\pfsoc_mss

The PolarFire SoC MSS Configurator can also be installed as a stand-alone application.

For information about how to install Libero, see [Libero SoC v12.0 and later](#).

2.1 Input and Output Files

The following sections describe the PolarFire SoC MSS Configurator input and output files.

2.1.1 Output Files

The PolarFire SoC MSS Configurator generates the output file formats shown in the following figure.

- **XML Configuration File** — Contains the MSS memory map, clock, DDR memory controller, and peripheral configuration. The XML file is used to generate hardware files required for building the firmware project.
- **CXZ File** — Encapsulates the hardware design of the MSS block and can be imported into Libero SoC project.

Figure 2-1. PolarFire SoC MSS Configurator Block Diagram

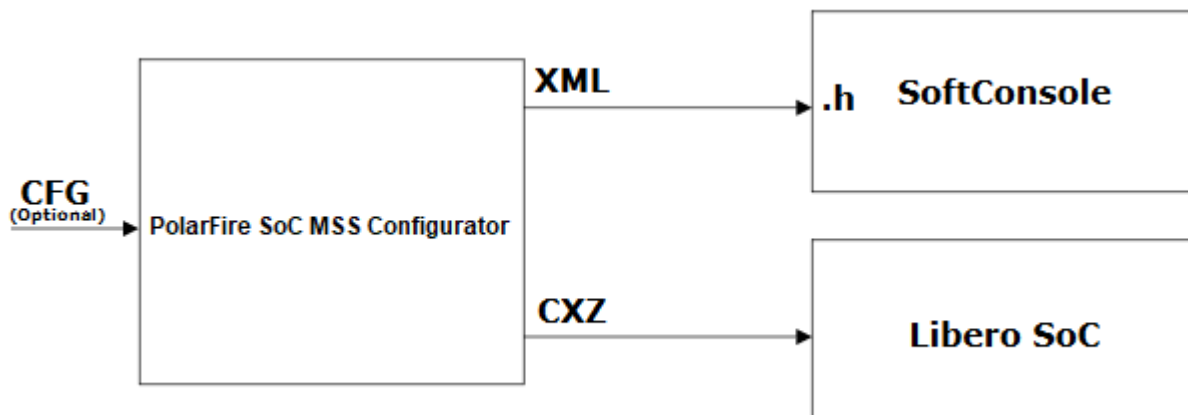

2.1.2 Input files

The PolarFire SoC MSS Configurator can be invoked without any input files. A configuration file (.cfg) from an earlier MSS configurator session can be optionally provided to the PolarFire SoC MSS Configurator.

Note: A .cfg file and a report file can also be generated from the PolarFire SoC MSS Configurator.

3. Running the PolarFire SoC MSS Configurator

You can run the PolarFire SoC MSS Configurator in Batch mode or Interactive mode.

3.1 Batch Mode

The PolarFire SoC MSS Configurator application can be executed in the Batch mode for scripted execution as follows:

- Windows®:

```
<Libero SoC or Standalone MSS Configurator installation area>\bin64\pfsoc_mss.exe -
GENERATE -CONFIGURATION_FILE:<absolute or relative path for configuration file name
(.cfg)> -OUTPUT_DIR:<absolute or relative path for output directory> -EXPORT_HDL:<true/
false> -LOGFILE:<absolute or relative path for logfile file name>
```

-EXPORT_HDL and -LOGFILE are optional arguments.

- Linux®:

```
<Libero SoC or Standalone MSS Configurator installation area>/bin64/pfsoc_mss.exe -
GENERATE -CONFIGURATION_FILE:<absolute or relative path for configuration file name
(.cfg)> -OUTPUT_DIR:<absolute or relative path for output directory> -EXPORT_HDL:<true/
false> -LOGFILE:<absolute or relative path for logfile file name>
```

-EXPORT_HDL and -LOGFILE are optional arguments.

3.2 Interactive Mode

In the Interactive (GUI) mode, the PolarFire SoC MSS Configurator provides the following high-level options.

Table 3-1. Configurator-Project Menu Options

Option	Description
New	Starts configuring a new MSS subsystem.
Open	Opens a configuration (.cfg) file.
Save/Save As	Saves the current configuration of the MSS subsystem to a configuration (.cfg) file.
Generate	Generates MSS configuration (.xml) and component (.cxz) files after configuring the MSS subsystem.
Close	Closes the current configuration (.cfg) file.

PolarFire SoC MSS Configurator can also be invoked in GUI mode for a specific configuration file as below:

- Windows:

```
<Libero SoC or Standalone MSS Configurator installation area>\bin64\pfsoc_mss.exe
-CONFIGURATION_FILE:<absolute or relative path for configuration file name (.cfg)>
-OUTPUT_DIR:<absolute or relative path for output directory>
```

- Linux:

```
<Libero SoC or Standalone MSS Configurator installation area>/bin64/pfsoc_mss.exe
-CONFIGURATION_FILE:<absolute or relative path for configuration file name (.cfg)>
-OUTPUT_DIR:<absolute or relative path for output directory>
```



Important: `-OUTPUT_DIR` is an optional argument in GUI mode. If specified, the default output directory location in GUI will always point to the specified location.

3.3 Using the PolarFire SoC MSS Configurator GUI

The PolarFire SoC MSS Configurator GUI has the following tabs.

- Peripherals
- DDR Memory
- L2 Cache
- Crypto
- MSS to/from Fabric Interface Controllers
- Clocks
- MSS I/O Attributes
- Memory Partition and Protection
- Misc

3.3.1 Clocks

Use the **Clocks** tab to configure the MSS PLL clock frequency and clock sources. For more information, see the [PolarFire FPGA and PolarFire SoC FPGA Clocking Resources User Guide](#).

There are three PLLs inside MSS, which generates the necessary clocks:

- MSS PLL
- DDR PLL
- SGMII PLL

Each PLL generates four output clocks from one input reference clock.

The actual output that PLL Solver generates is shown in GUI next to the **Actual:** label. If the requirement is met, the color of the label is blue. If it is not met (from you), it is red.

In MSS PLL, you must specify the four output clock requirements.

- Output 0 (CPU Clock)
- Output 1 (Crypto Clock)
- Output 2 (eMMC Clock)
- Output 3 (CAN Clock)

The following conditions pose restrictions on the PLL solver. Solver attempts to solve the fixed requirements first and then the ones without restriction.

1. When eMMC is enabled, the output clock requirement is fixed at 200 MHz.
2. When the CAN peripheral is enabled, the output clock requirement must be multiple of 8 (max 80 MHz).
3. Crypto can be at most 200 MHz.
4. CPU has the maximum frequency of 625 MHz.

In DDR PLL, enter the required output clock frequency in the DDR tab in Line Edit 'Memory clock frequency'. All four output clocks are generated by PLL that is the same frequency.

In SGMII PLL, the output frequency requirement is fixed at 625 MHz for all four outputs. You do not have to enter this. Additionally, the output clocks are phase-shifted by 90° (output 0 clock has 0° phase shift, output 1 clock has 90°, and so on).

The following table lists the option provided in the MSS **Clocks** selection tab.

Table 3-2. MSS Clock Selection Tab

Option	Description
eMMC/SD/SDIO clock source	eMMC/SD/SDIO can be clocked either through MSS PLL or Fabric I/O.
CAN clock source	CAN can be clocked either through MSS PLL or Fabric I/O.
MSS PLL Reference Clock Source	MSS can be clocked from dedicated I/O from Bank 5 (REFCLK) or North West PLL output.
MSS PLL required clock frequency	<ul style="list-style-type: none"> For STD speed, you can set the frequency value of up to 625 MHz. For -1 speed, you can set the frequency value of up to 667 MHz. <p>All MSS clock frequencies are derived from this setting.</p>
MSS CPU cores clock frequency Divider	The MSS CPU clock frequency is based on the MSS PLL clock frequency and is set using the divider values /1, /2, /4, or /8. The frequency must be greater or equal to the MSS AXI clock, and can have a maximum value of 667 MHz for -1 speed and 625 MHz for STD speed.
MSS AXI clock frequency Divider	The MSS AXI clock frequency is based on the MSS CPU clock frequency and is set using the divider values of /1, /2, /4, or /8. The frequency must be greater or equal to MSS AHB/APB clock, and can have a maximum value of 333.50 MHz for -1 speed and 312.50 MHz for STD speed.
MSS AHB/APB clock frequency Divider	The MSS AHB/APB clock frequency is based on the MSS CPU clock frequency and is set using the divider values /2, /4, or /8. The maximum supported frequency is 166.75 MHz for -1 speed and 156.25 MHz for STD speed.
DDR Reference Clock Source	You can select the North West (NW) PLL ports or I/Os from Bank 5.
RTC/MAC SGMII Reference Clock Input Source	You can select the NW PLL ports or I/Os from Bank 5.
Dedicated I/O from Bank5 (REFCLK) frequency	This is a dedicated I/O from Bank 5 to the MSS PLL. It can either be 100 MHz or 125 MHz.
NW PLL (REF_0_PLL_NW) frequency (MHz)/NW PLL (REF_1_PLL_NW) frequency (MHz)	This option is available when any peripheral is clocked from NW PLL output. It can be any value between 50 MHz to 125 MHz.
Crypto clock frequency from MSS (MHz)	You can set the reference clock frequency for Crypto between 1 MHz to 200 MHz.
MSS CAN clock frequency (MHz)	The MSS CPU clock frequency is based on the MSS PLL clock frequency. The supported frequencies in MHz are 8, 16, 24, 32, 40, 48, 56, 64, 72, and 80.

Note: The **DDR Reference Clock Input Source** option appears only when the DDR memory type is selected from the **DDR Memory** tab.

The following figure shows the **Clocks** tab in the PolarFire SoC MSS Configurator. In this example, the following configurations are used:

- Dedicated I/Os from Bank 5 (REFCLK) are selected as the reference clock input source for the MSS. The MSS PLL clock frequency is set to 600 MHz.
- Dedicated I/Os from Bank 5 (REFCLK) are used to source the reference clock input frequency for the DDR subsystem.

- The DDR clock source and MSS clock source are set to 125 MHz.

Figure 3-1. Clocks Tab

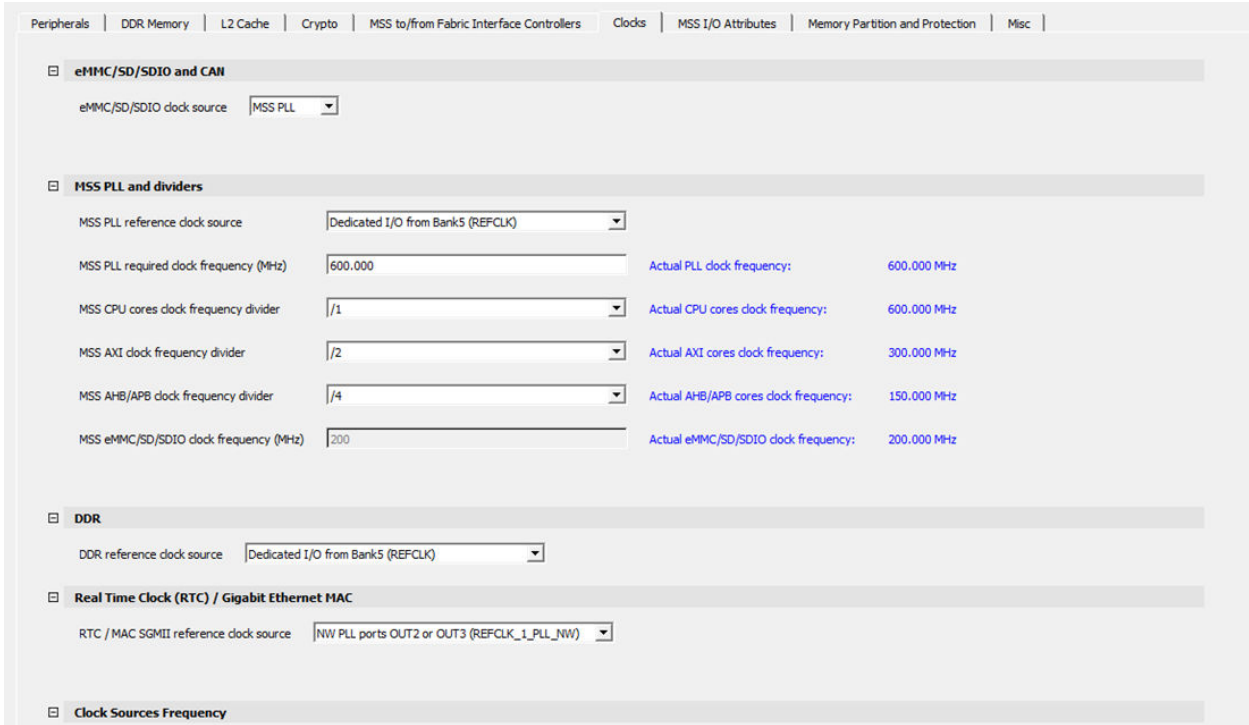

The following figure shows the **Clocks** tab with PLL in the PolarFire SoC MSS Configurator. In this example, the following configuration is used:

- NW PLL ports OUT2 or OUT3 (REFCLK_0_PLL_NW) are selected as the reference clock input source for the MSS. The MSS PLL clock frequency is set to 600.000 MHz.
- NW PLL ports OUT2 or OUT3 (REFCLK_1_PLL_NW) are used to source the reference clock input frequency for the DDR subsystem and Real Time Clock/Gigabit Ethernet MAC.
- The DDR Clock Source and MSS Clock Source are set to 100 MHz.

Figure 3-2. Clocks Tab with PLL

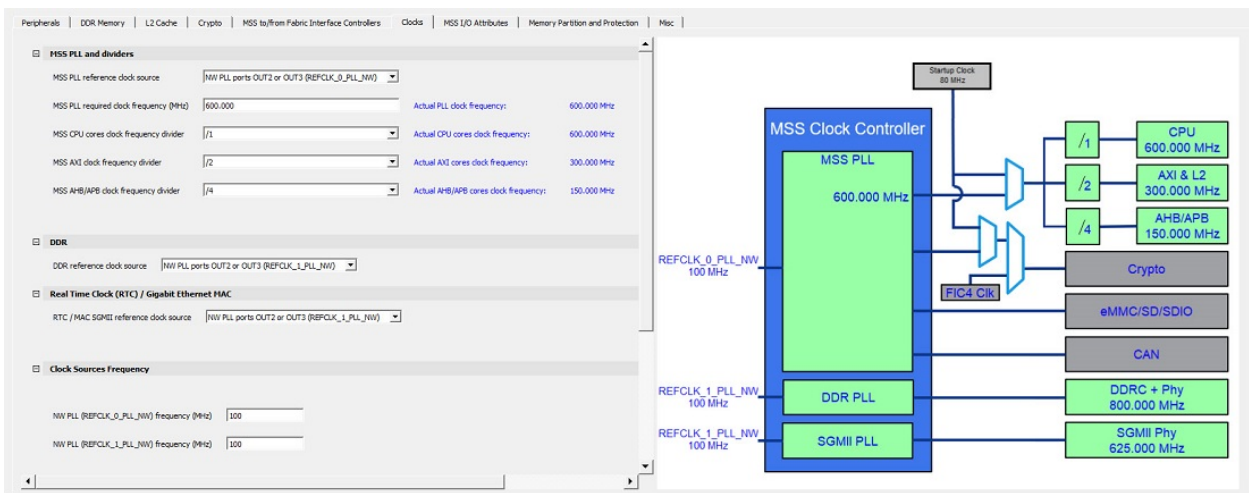

For more information about configuring the MSS DDR subsystem, see [DDR Memory](#).

3.3.2 MSS To/From Fabric Interface Controllers

Using the **MSS to/from Fabric Interface Controllers** tab, any combination of **FIC_0**, **FIC_1**, **FIC_2**, and **FIC_3** can be enabled and configured to support initiator and target interfaces. For more information, see the [PolarFire SoC FPGA MSS Technical Reference Manual](#).

FIC_0, **FIC_1**, and **FIC_2** support AXI4 interfaces, while **FIC_3** supports APB.

For **FIC_0** and **FIC_1** interfaces, both initiator and target interfaces can be enabled at the same time. **FIC_2** interface can support only target interface, and **FIC_3** interface can only support initiator interface (MSS is initiator).

FIC_0 and **FIC_1** have both initiator and target interfaces to and from the FPGA fabric, while **FIC_2** and **FIC_3** support target or initiator interfaces, respectively.

The **Jitter Range** for the Embedded DLLs can be selected in the **Fabric Interface Controller** tab. The **Embedded DLL Jitter Range** drop down has the following options.

- Low
- Medium Low
- Medium High
- High



Important: The default selection is Medium Low.

The following figure shows all FIC options available and enabled. By default, the DLLs of all the FICs are enabled.

Figure 3-3. MSS to/from Fabric Interface Controllers Tab

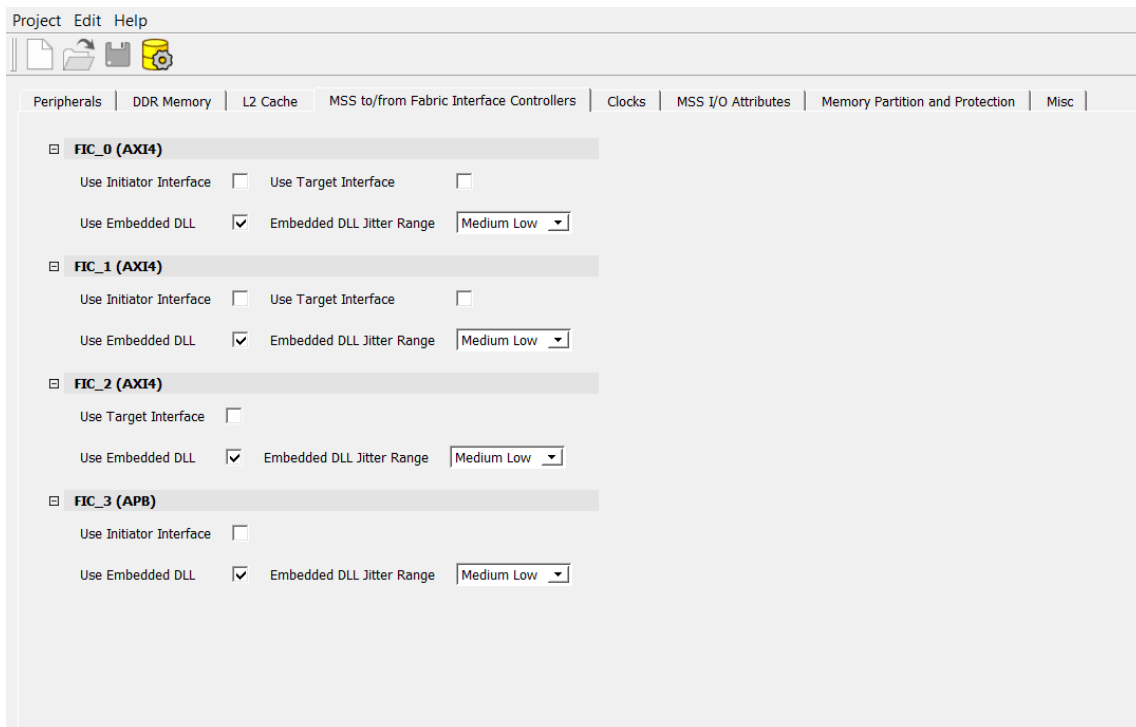



Important: The FIC interface can operate up to 250 MHz. The FIC clock is independent of the MSS clock. If the frequency of the FIC block is greater than or equal to 125 MHz, the embedded DLL must be enabled to remove the clock insertion delay. If the frequency of the FIC block is less than 125 MHz, the embedded DLL must be bypassed.

When an initiator interface is enabled for a FIC, that initiator interface must be connected to a target in the fabric. When a target interface is enabled for an FIC, that target interface must be connected to an initiator in the fabric.

There is a clock domain crossing logic in the FIC block to address the asynchronous MSS and Fabric clocks and therefore, user logic is not required to implement clock domain crossing synchronization for this interface.

Figure 3-4. FIC Interfaces Enabled

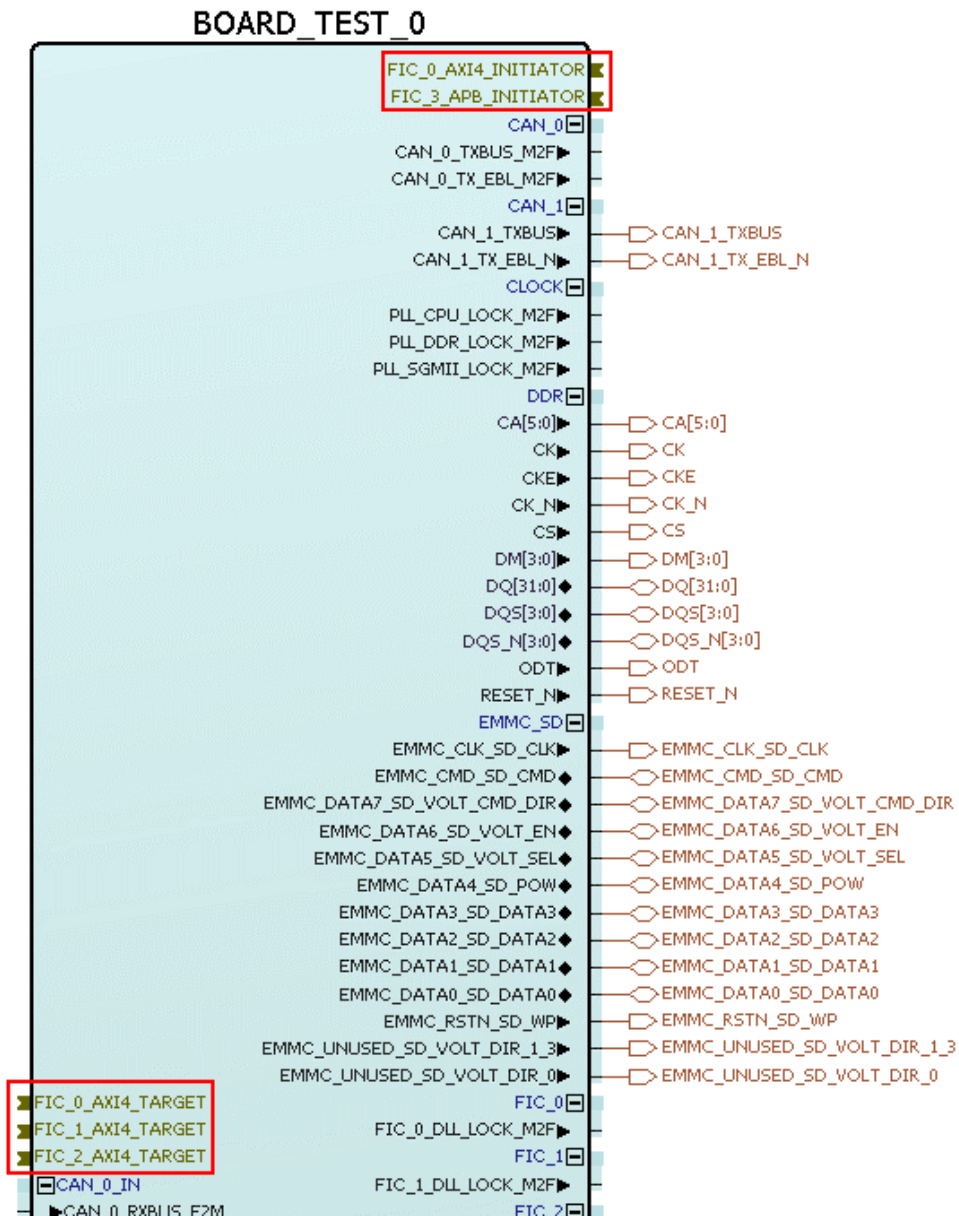

Note: The MSS SmartDesign component is visible only after importing the MSS CXZ file.

3.3.3 Peripherals

Select the following I/Os using the **Peripherals** tab:

- GPIOs from Bank 2 and Bank 4, which are dedicated to the MSS.
- Fabric I/Os, if the dedicated I/Os from Bank 2 and Bank 4 are not available.
- GPIOs from Bank 5 are dedicated to SGMII but can be routed to GMII or MII fabric I/Os. GPIO from Bank 5 are displayed only when Gigabit Ethernet MAC_0 or Gigabit Ethernet MAC_1 is selected.



Important: I/Os from the DDR bank are dedicated to the DDR Controller in the MSS.

For more information, see the [PolarFire SoC FPGA MSS Technical Reference Manual](#). The following figure shows the **Peripherals** tab on the PolarFire SoC MSS Configurator.

Figure 3-5. Peripherals Tab

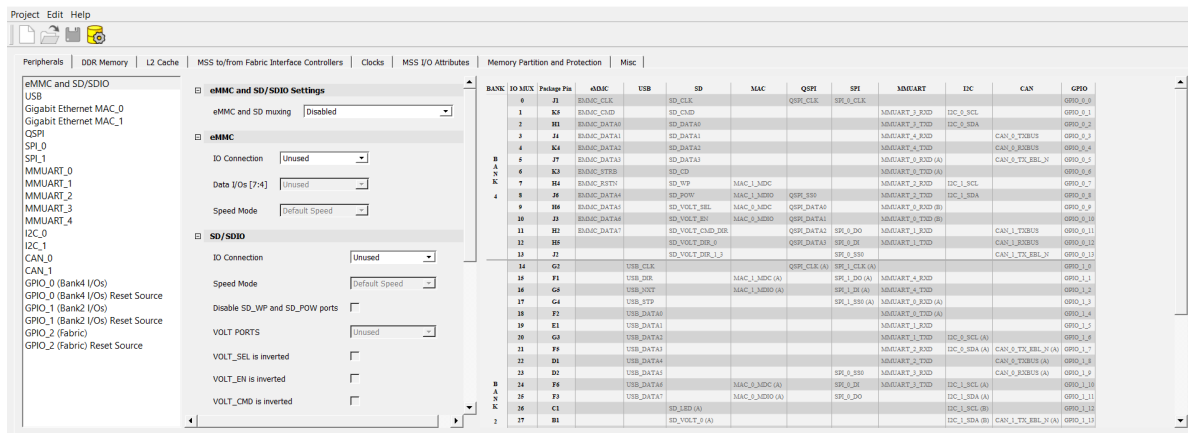

By default, all peripherals are marked as **Unused**. To include peripherals that are required in the design, select the peripheral from the left-hand side of the window and use the corresponding drop-down to assign MSS I/Os or fabric I/Os.

The I/Os associated with the following peripherals are dedicated and cannot be assigned to fabric I/Os:

- USB peripherals are dedicated in Bank 2.
- eMMC peripherals are dedicated in Bank 4.
- Ports SD_POW and SD_WP can be disabled when not in use and can be used for other interfaces.
- SD/SDIO peripherals are dedicated in Bank 4.

The GPIOs in Bank 2 and Bank 4 have the following options.

- Unused
- MSS I/Os Bank2/4
- Static High
- Static Low



Important:

- **Static High** and **Static Low** can only be set when **eMMC and SD muxing** is enabled.
- **GPIO_2 (Fabric)** does not support **Static High** and **Static Low** options.

According to the options selected, the affected GPIOs are highlighted in green, as shown in the following figure.

Figure 3-6. GPIO Options

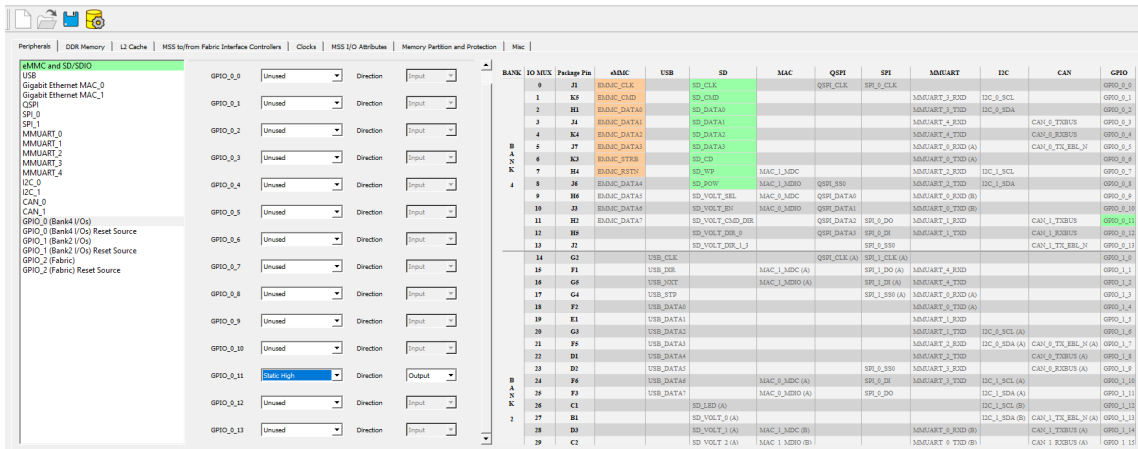

Note: If the I/Os for a peripheral are selected in a bank, you cannot select the same I/Os for another peripheral from the same bank. If you try, the tool generates the following error message in the log window:

I/O placement errors were detected in Peripherals Tab.

Figure 3-7. I/O Placement Error Message in Log Window

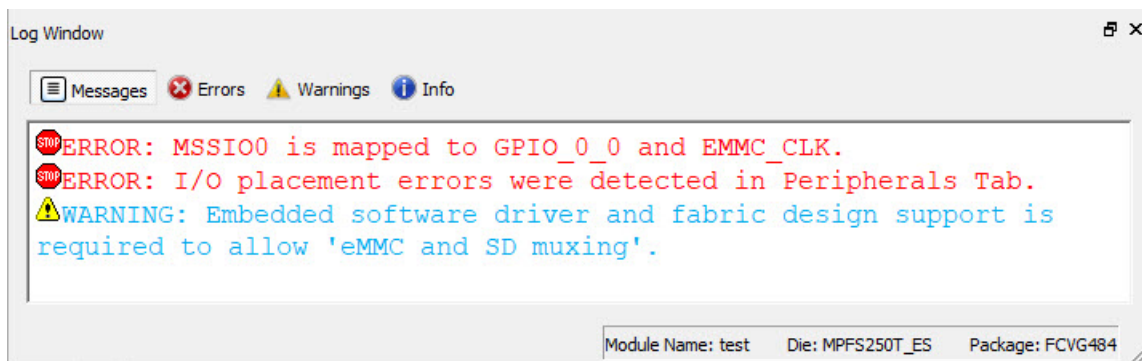

You can choose to enable either eMMC or SD at power-up using the eMMC and SD muxing option. The highlighted green-colored ports denote which I/O setting is active, whereas the orange-colored ports indicate which I/O setting is inactive.

The following warning message is generated in the log window, when the eMMC or SD setting is enabled.

Embedded software driver and fabric design support is required to allow 'eMMC and SD muxing'.

The eMMC and SD cannot be used simultaneously, as shown in the following figure.

Figure 3-8. Overlapping I/O Warning

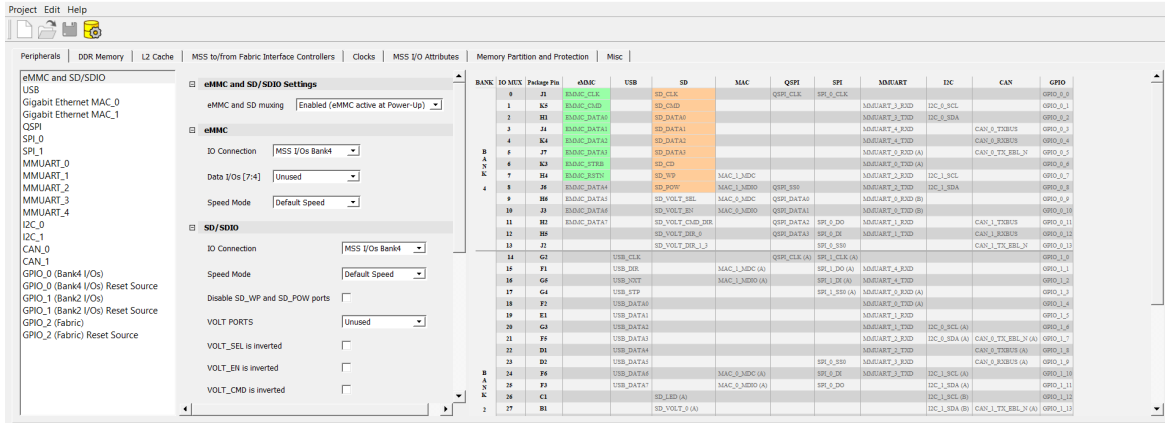

3.3.4 MSS I/O Attributes

MSS I/Os are present in Bank2, Bank4, and Bank5. The attributes present for each bank are as explained as shown in the following.

3.3.4.1 Bank2 I/Os

The MSS I/Os are available across Bank2. The **Bank2 I/Os** tab allows you to select the electrical characteristics of the MSS I/Os. Each MSS I/O along with the settings must be enabled one-by-one.

Figure 3-9. Bank2 I/Os Tab

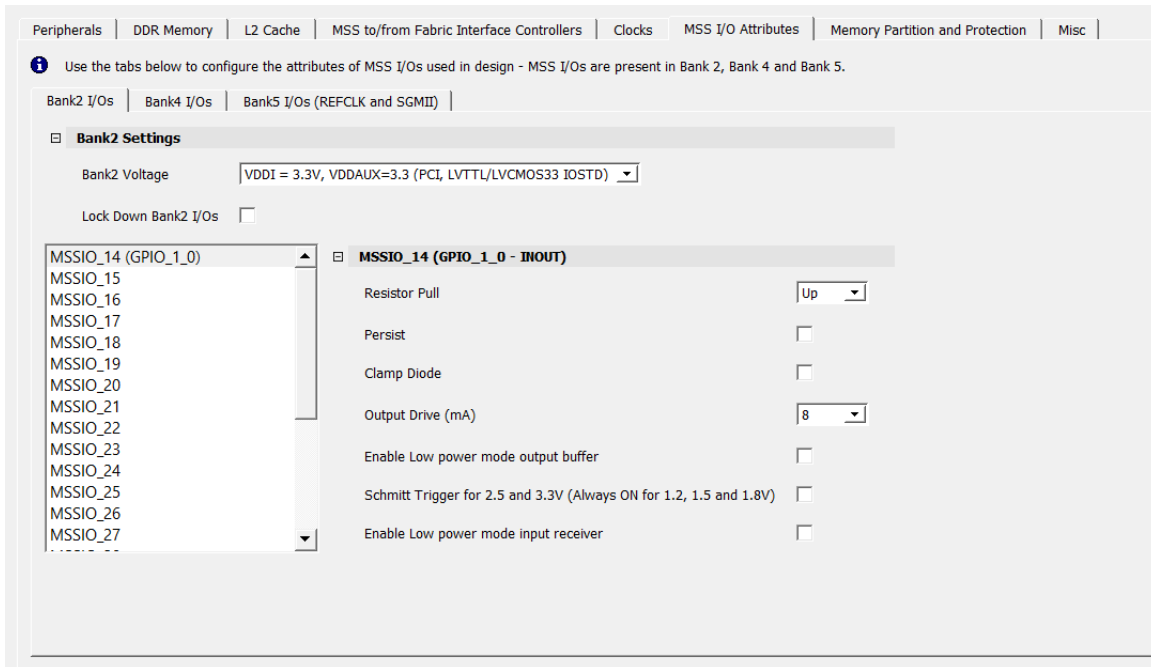

Note: Enable the Lock Down Bank2 I/Os option to lock all the Bank2 MSSIOs.

The following table lists the I/O standards and the output drive.



Important: This is applicable to Bank2 and Bank4 MSSIOs only.

Table 3-3. I/O Standard and Output Drive

Protocol	Speed Mode	LVC MOS Standard	Output Current Drive	Supported Out Drive Values
USB 2.0	High	3.3V	8 mA-20 mA	8, 12, 16, and 20 mA
		2.5V	6 mA-16 mA	6, 8, 12, and 16 mA
		1.8V	6 mA-12 mA	6, 8, 10, and 12 mA
eMMC	Default speed	3.3V	3.3V => 2-20 mA	2, 4, 8, 12, 16, and 20 mA
		1.8V	1.8V => 2-10 mA	2, 4, 6, 8, and 10 mA
		1.2V	1.2V => 2-8 mA	2, 4, 6, and 8 mA
	High speed	3.3V	3.3V => 4-20 mA	4, 8, 12, 16, and 20 mA
		1.8V	1.8V => 4-10 mA	4, 6, 8, and 10 mA
		1.2V	1.2V => 4-8 mA	4, 6, and 8 mA
	High speed DDR	3.3V	3.3V => 2-20 mA	2, 4, 8, 12, 16, and 20 mA
		1.8V	1.8V => 2-10 mA	2, 4, 6, 8, and 10 mA
		1.2V	1.2V => 2-8 mA	2, 4, 6, and 8 mA
	HS200	1.8V	1.8V => 6-10 mA	6, 8, and 10 mA
		1.2V	1.2V => 4-8 mA	4, 6, and 8 mA
	HS400	1.8V	1.8V => 4-10 mA	4, 6, 8, and 10 mA
		1.2V	1.2V => 4-8 mA	4, 6, and 8 mA
	HS400-ES	1.8V	1.8V => 4-10 mA	4, 6, 8, and 10 mA
		1.2V	1.2V => 4-8 mA	4, 6, and 8 mA
SDIO	Low Speed	3.3V	2 mA-20 mA	2, 4, 8, 12, 16, and 20 mA
	Full Speed	3.3V	2 mA-20 mA	2, 4, 8, 12, 16, and 20 mA
SD	Default speed	3.3V	2 mA-20 mA	2, 4, 8, 12, 16, and 20 mA
	High speed	3.3V	4 mA-20 mA	4, 8, 12, 16, and 20 mA
	SDR12	1.8V	2 mA-10 mA	2, 4, 6, 8, and 10 mA
	SDR25	1.8V	4 mA-10 mA	4, 6, 8, and 10 mA
	SDR50	1.8V	4 mA-10 mA	4, 6, 8, and 10 mA
	DDR50	1.8V	4 mA-10 mA	4, 6, 8, and 10 mA
	SDR104	1.8V	6 mA-10 mA	6, 8, and 10 mA
CAN	—	3.3V	2 mA-20 mA	2, 4, 8, 12, 16, and 20 mA

Libero® SoC v2022.3

Running the PolarFire SoC MSS Configurator

.....continued				
Protocol	Speed Mode	LVCMOS Standard	Output Current Drive	Supported Out Drive Values
QSPI		3.3V	3.3V => 8-20 mA	8, 12, 16, and 20 mA
		2.5V	2.5V => 8-16 mA	8, 12, and 16 mA
		1.8V	1.8V => 8-12 mA	8, 10, and 12 mA
		1.5V	1.5V => 8-10 mA	8 mA
		1.2V	1.2V => 6-8 mA	6 and 8 mA
SPI	Initiator	3.3V	3.3V => 8-20 mA	8, 12, 16, and 20 mA
		2.5V	2.5V => 8-16 mA	8, 12, and 16 mA
		1.8V	1.8V => 8-12 mA	8, 10, and 12 mA
		1.5V	1.5V => 8-10 mA	8 mA
		1.2V	1.2V => 6-8 mA	6 and 8 mA
	Target	3.3V	3.3V => 8-20 mA	8, 12, 16, and 20 mA
		2.5V	2.5V => 8-16 mA	8, 12, and 16 mA
		1.8V	1.8V => 8-12 mA	8, 10, and 12 mA
		1.5V	1.5V => 8 - 10 mA	8 mA
		1.2V	1.2V => 6-8 mA	6 and 8 mA
MMUART	—	3.3V	3.3V => 2-20 mA	2, 4, 8, 12, 16, and 20 mA
		2.5V	2.5V => 4-16 mA	4, 6, 8, 12, and 16 mA
		1.8V	1.8V => 4-12 mA	4, 6, 8, 10, and 12 mA
I2C	Standard	3.3V	3.3V => 2-20 mA	2, 4, 8, 12, 16, and 20 mA
		1.8V	1.8V => 2 - 10 mA	2, 4, 6, 8, and 10 mA
	Fast	3.3V	3.3V => 2-20 mA	2, 4, 12, 16, and 20 mA
		1.8V	1.8V => 2-10 mA	2, 4, 6, 8, and 10 mA
Ethernet MAC(MDIO)	PHY Management Interface	3.3V	3.3V => 8-20 mA	8, 12, 16, and 20 mA
		2.5V	2.5V => 8-16 mA	8, 12, and 16 mA
		1.8V	1.8V => 8-12 mA	8, 10 and 12 mA
		1.5V	1.5V => 8 - 10 mA	8 mA
		1.2V	1.2V => 6-8 mA	6 and 8 mA
GPIO	—	3.3V	3.3V => 2-20 mA	2, 4, 8, 12, 16, and 20 mA
		2.5V	2.5V => 2-16 mA	2, 4, 6, 8, 12, and 16 mA
		1.8V	1.8V => 2-12 mA	2, 4, 6, 8, 10, and 12 mA
		1.5V	1.5V => 2-8 mA	2, 4, 6, and 8 mA
		1.2V	1.2V => 2-8 mA	2, 4, 6, and 8 mA

When a peripheral supports multiple speed modes, the following must be followed.

- I/O standard check must be specific for the peripheral and the speed mode is selected.
- Support for out drive values depends on the peripheral type, the speed mode, and the I/O Standard.

3.3.4.2 Bank4 I/Os

The MSS I/Os are available across Bank 4. The **Bank4 I/Os** tab allows you to select the electrical characteristics of the MSS I/Os. Each MSS I/O along with the settings must be enabled one by one.

Figure 3-10. Bank4 I/Os Tab

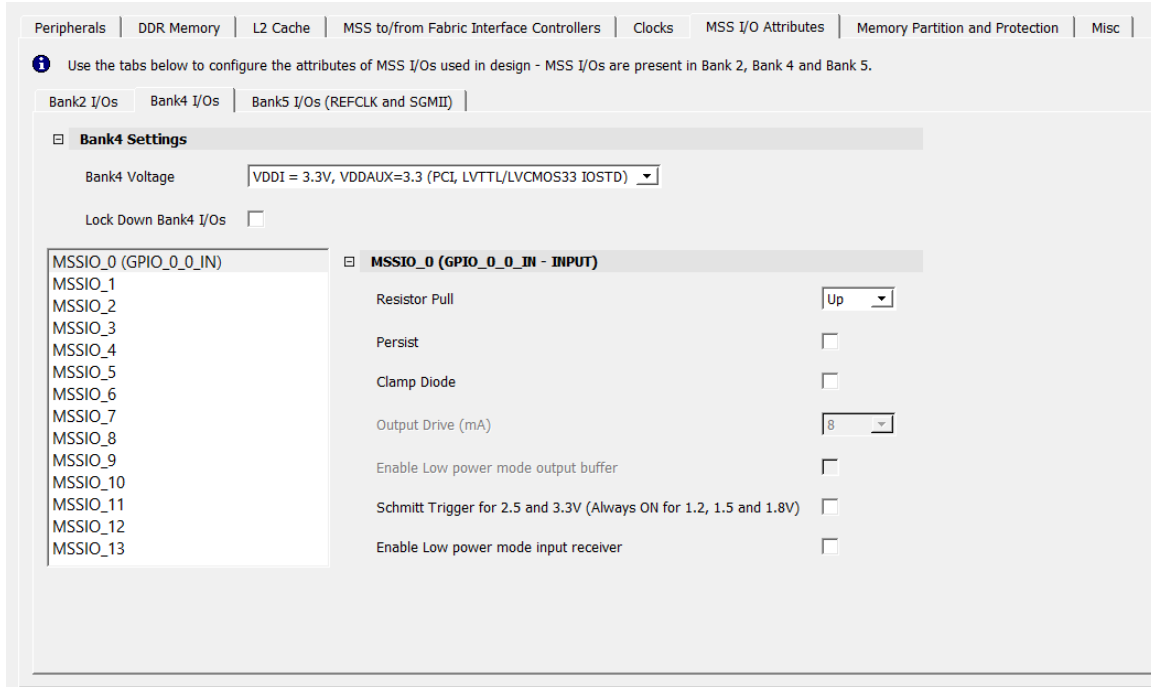

Important: Enable the Lock Down Bank4 I/Os option to lock all the Bank4 MSSIOs.

3.3.4.3 Bank5 I/Os (REFCLK and SGMII)

Using the Bank5 I/Os (REFCLK and SGMII) tab, you can select the electrical characteristics of the Bank5 I/Os, as shown in the following figure. The tool generates a warning in the log window for unsupported selections.

Figure 3-11. Bank5 I/Os (REFCLK and SGMII) Tab with RefClk I/O Setting Option Selected

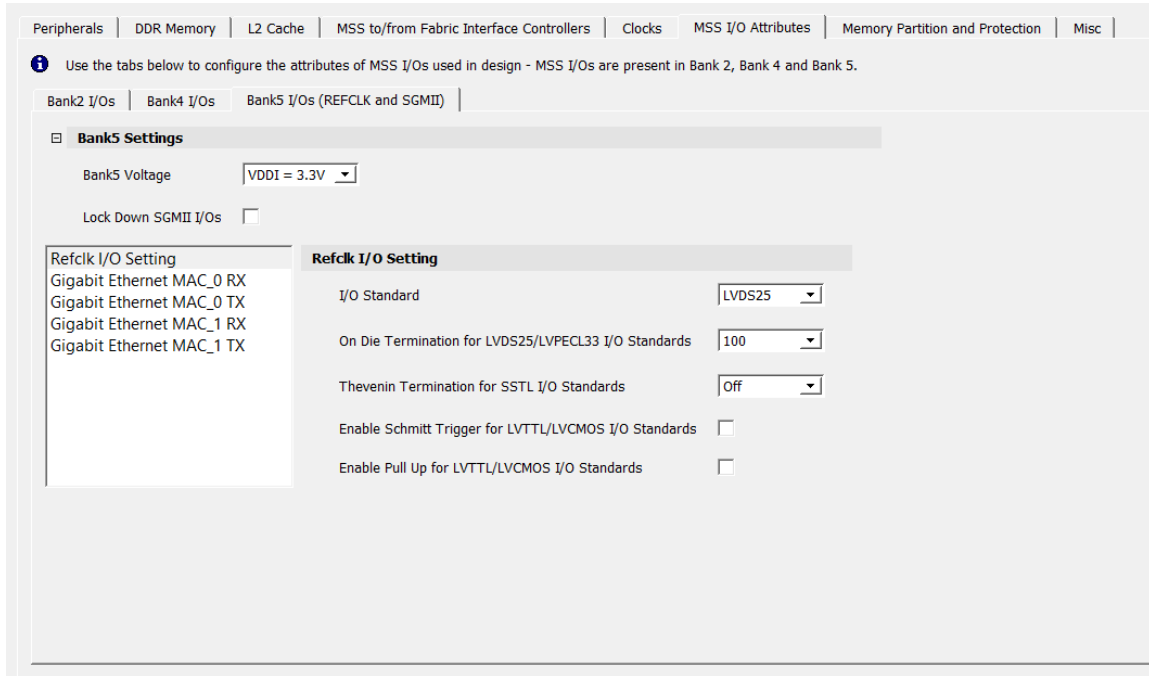

Important: Enable the Lock Down SGMII I/Os option to lock all the SGMII I/Os.

PolarFire SoC supports two full-duplex SGMII channels (Channel0 and Channel1). Each channel has one RX and one TX. There are two input and two output I/Os that must be configured for SGMII, and all I/Os are differential.

SGMII Inputs

MAC_0 (Channel0) RX and MAC_1 (Channel1) RX are inputs and have the following options:

- I/O Standard



Important: The IOSTD must match the bank voltage in the **Refclk I/O Setting** section. For example, if the bank 5 voltage VDDI is 3.3 V, you cannot set SGMII I/Os to any IOSTD, which is 2.5 V such as LVDS25, RSDS25, MINILVDS25, SUBLVDS25, PPDS25, and LCMDS25.

- Resistor Pull
- VCM Range
- On Die Termination (Ohm)

The following figure shows the SGMII RX.

Figure 3-12. Bank5 I/Os (REFCLK and SGMII) Tab with Gigabit Ethernet MAC_0 RX Option Selected

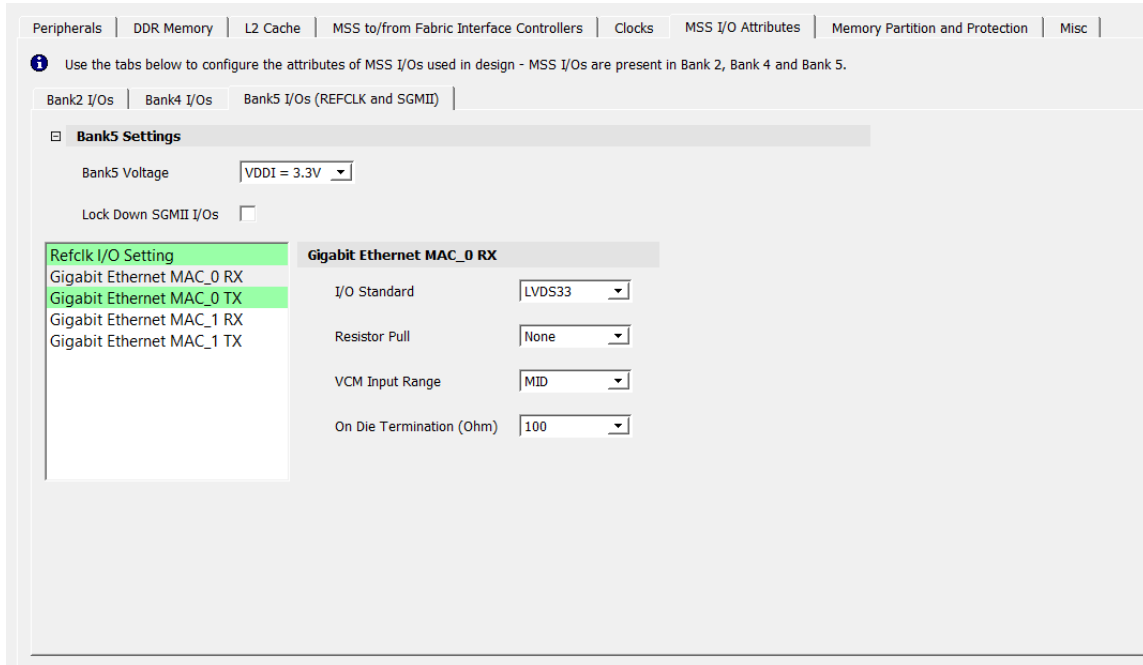

SGMII RX Register Settings

The following table lists the Channel 0/Channel 1 RX register settings.

Table 3-4. Channel 0/1 RX Register Settings

GUI Labels/Parameter Name	Options
I/O Standard	LVDS33, LVDS25, RSDS33, RSDS25, MINILVDS33, MINILVDS25, SUBLVDS33, SUBLVDS25, PPDS33, PPDS25, LCMDS33, LCMDS25
Resistor Pull	None, Up, Down
VCM Input Range	MID, LOW
On Die Termination (Ohm)	OFF, 100

SGMII Outputs

MAC_0 (Channel0) TX and MAC_1 (Channel1) TX are outputs and have the following options:

- I/O Standard
- Resistor Pull
- Output Drive
- Source Termination (Ohm)

The following figure shows the SGMII TX.

Figure 3-13. Bank5 I/Os(REFCLK and SGMII) Tab with Gigabit Ethernet MAC_1 TX Option Selected

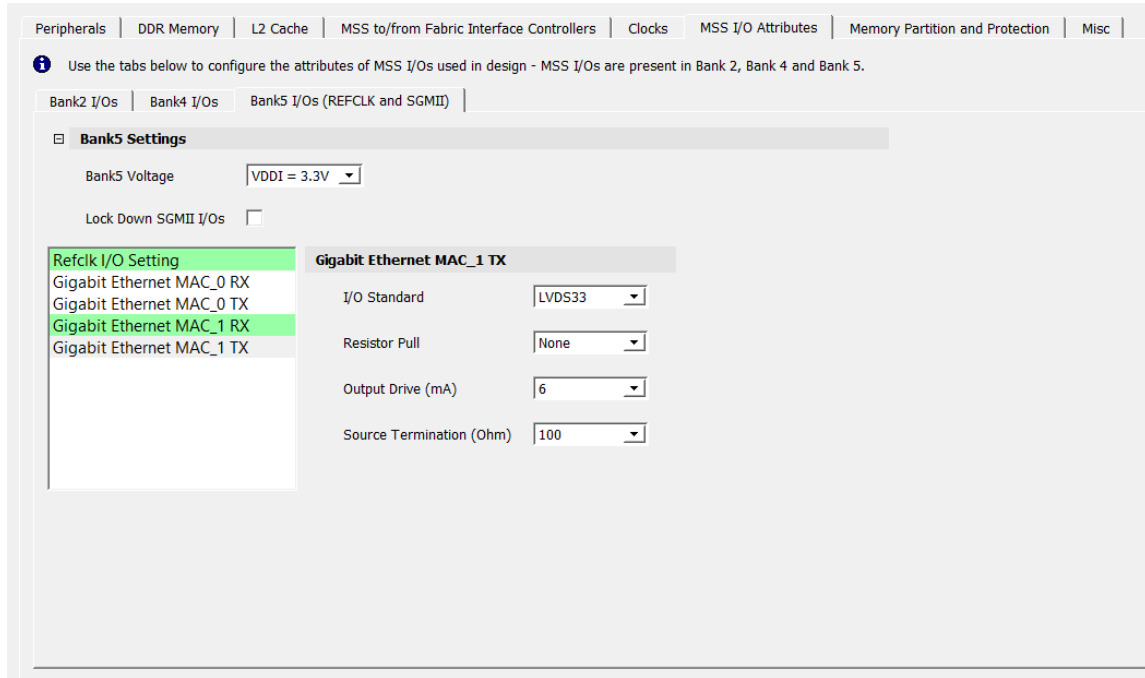

SGMII TX Register Settings

The following table lists the Channel 0/Channel 1 TX register settings.

Table 3-5. Channel 0 /1 TX Register Settings

GUI Labels/Parameter Name	Options
I/O Standard	LVDS33, LVDS25, RSDS33, RSDS25, MINILVDS33, MINILVDS25, SUBLVDS33, SUBLVDS25, PPDS33, PPDS25, LCMDS33, LCMDS25
Resistor Pull	None, Up, Down
Output Drive (mA)	1.5, 2, 3, 3.5, 4, 6
Source Termination (Ohm)	OFF, 100

SGMII Output I/O Standard Settings

Based on the selected I/O standards, you must enforce the following DRC checks:

Table 3-6. SGMII Output DRC Check

I/O_TYPE	Direction	Legal Output DRIVE Settings (mA)
LVDS33	Output	6, 4, 3.5, 3
LVDS25	Output	6, 4, 3.5, 3
RSDS33	Output	4, 3, 2, 1.5
RSDS25	Output	4, 3, 2, 1.5
MINILVDS33	Output	6, 4, 3.5, 3
MINILVDS25	Output	6, 4, 3.5, 3
SUBLVDS33	Output	3, 2, 1.5, 1

.....continued

I/O_TYPE	Direction	Legal Output DRIVE Settings (mA)
SUBLVDS25	Output	3, 2, 1.5, 1
PPDS33	Output	4, 3, 2, 1.5
PPDS25	Output	4, 3, 2, 1.5
LCMDS33	Output	6, 4, 3.5, 3
LCMDS25	Output	6, 4, 3.5, 3

I/O Standard and Supported Output Drive

Voltage selection for Bank 5 must match the I/O Standard selected for TX and RX in both channels.

Example 3-1.

Bank5 Voltage selection -> VDDI = 3.3V -> LVDS33 is legal but not LVDS25

Table 3-7. Legal Values/Settings for I/O_TYPE/Output Drive Combination

I/O_TYPE	Legal Output DRIVE Settings (mA)
LVDS33	6, 4, 3.5, 3
LVDS25	6, 4, 3.5, 3
RSDS33	4, 3, 2, 1.5
RSDS25	4, 3, 2, 1.5
MINILVDS33	6, 4, 3.5, 3
MINILVDS25	6, 4, 3.5, 3
SUBLVDS33	3, 2, 1.5, 1
SUBLVDS25	3, 2, 1.5, 1
PPDS33	4, 3, 2, 1.5
PPDS25	4, 3, 2, 1.5
LCMDS33	6, 4, 3.5, 3
LCMDS25	6, 4, 3.5, 3

3.3.4.4 Bank2 and Bank4 I/Os Related to SD and eMMC Muxing

The eMMC and SD peripherals use the same MSS I/Os, so both peripherals cannot be active at the same time. However, the PolarFire SoC MSS Configurator allows you to configure the electrical characteristics of the MSS I/Os related to both peripherals when **eMMC and SD muxing** is enabled in the **Peripherals** tab, where one of the peripherals (eMMC or SD) is active at power-up and the other peripheral is not active at power-up. The MSS I/Os related to a peripheral that is active at power-up is listed in **Bank2 I/Os** tab and **Bank4 I/Os** tab. MSS I/Os related to a peripheral that is not active at power-up is shown as follows:

In the highlighted tabs, you might be able to select the electrical characteristics of eMMC or SD MSS I/Os only (electrical characteristics of MSS I/Os related to any other peripherals are grayed-out).

- If **eMMC and SD muxing** is selected as **Enabled (eMMC active at Power-Up)** in **Peripherals** tab, the highlighted tabs will be shown to the user.



Important: The eMMC MSS I/Os are listed under Bank2/Bank4 I/Os tabs, and SD MSS I/Os are listed in the highlighted tabs.

Figure 3-14. Bank2 and Bank4 SD I/Os Tabs

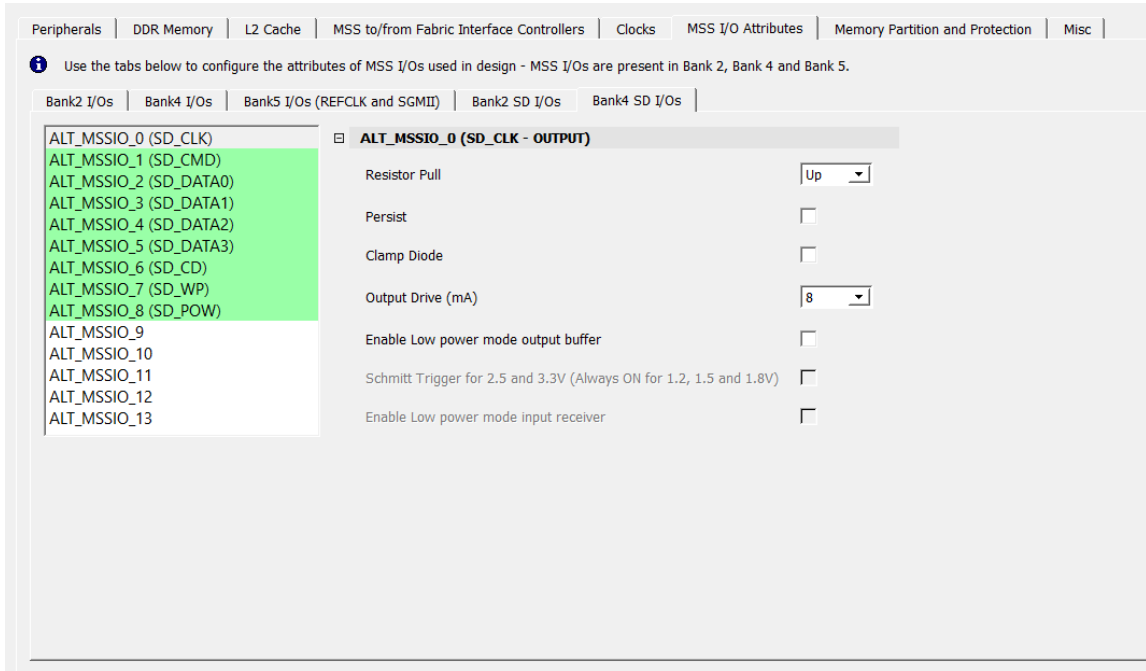

- If **eMMC and SD muxing** is selected as **Enabled (SD active at Power-Up)** in **Peripherals** tab, the highlighted tabs will be shown to the user.



Important: The SD MSS I/Os are listed under Bank2/Bank4 I/Os tabs, and eMMC MSS I/Os are listed in the highlighted tabs.

Figure 3-15. Bank2 and Bank4 eMMC I/Os Tabs

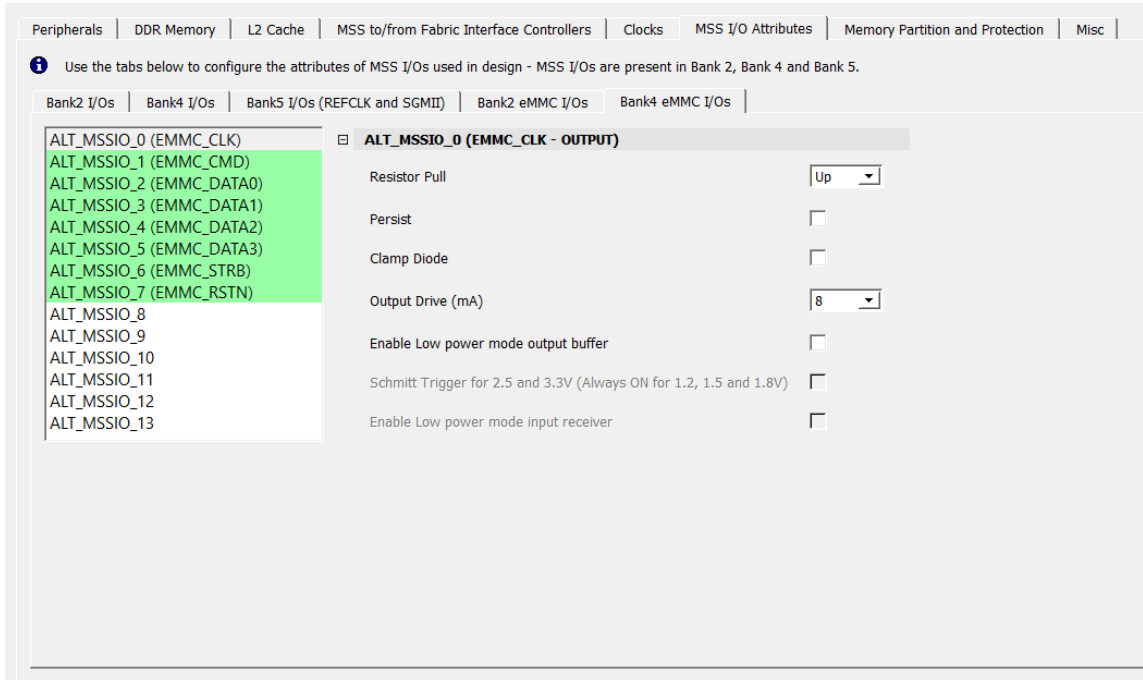

Important: When **eMMC and SD muxing** is enabled, the user must ensure that the required embedded software driver and fabric design support is available to dynamically switch between eMMC and SD peripherals.

When **eMMC and SD muxing** is enabled, MSSIO PADS can be configured as Pull-Up or Pull-Down by selecting GPIOs as **Static High** or **Static Low**. When **Static High** or **Static Low** is selected for a GPIO in Bank 4 or Bank 2, all the I/O attributes of the corresponding MSSIO are greyed out except **Output Drive**. **Resistor Pull** is set to **Up** when **Static High** is selected and to **Down** when **Static Low** is selected by default for the corresponding MSSIOs in **Bank2 I/Os** and **Bank4 I/Os** tab and vice versa in the **Bank2 eMMC(SD) I/Os** and **Bank4 eMMC(SD) I/Os** tab.

For example: when **Static High** is selected for `GPIO_0_13` in the **Peripherals** tab, the **MSSIO I/O Attributes** tab will be setup as follows.

- Bank4 I/Os settings are shown in the following figure.

Figure 3-16. Bank4 I/O Settings

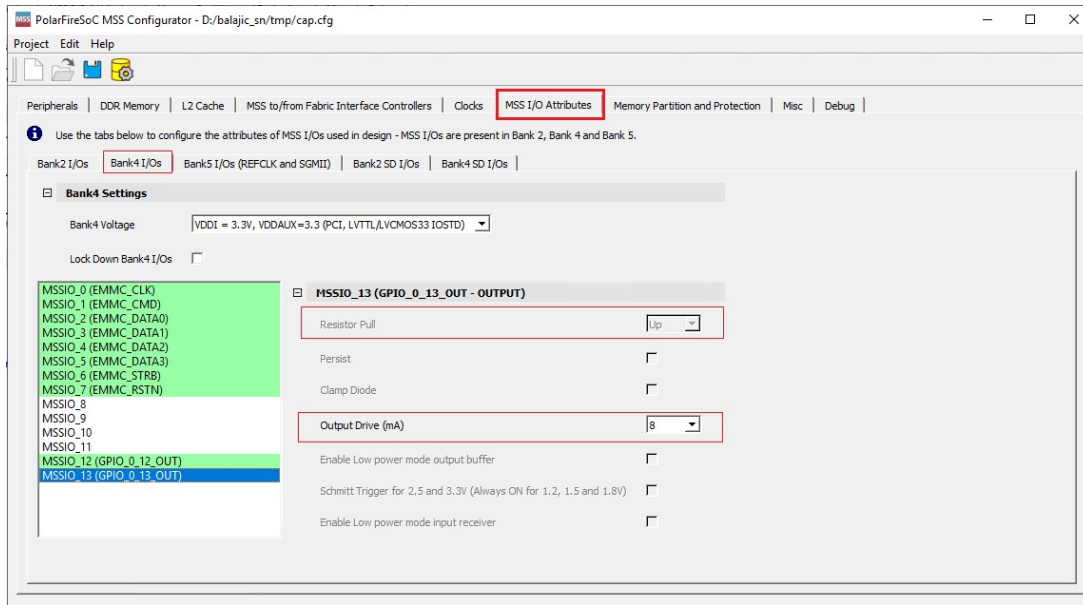

- Alternate Bank4 I/Os settings are shown in the following figure.

Figure 3-17. Alternate Bank4 I/Os Settings

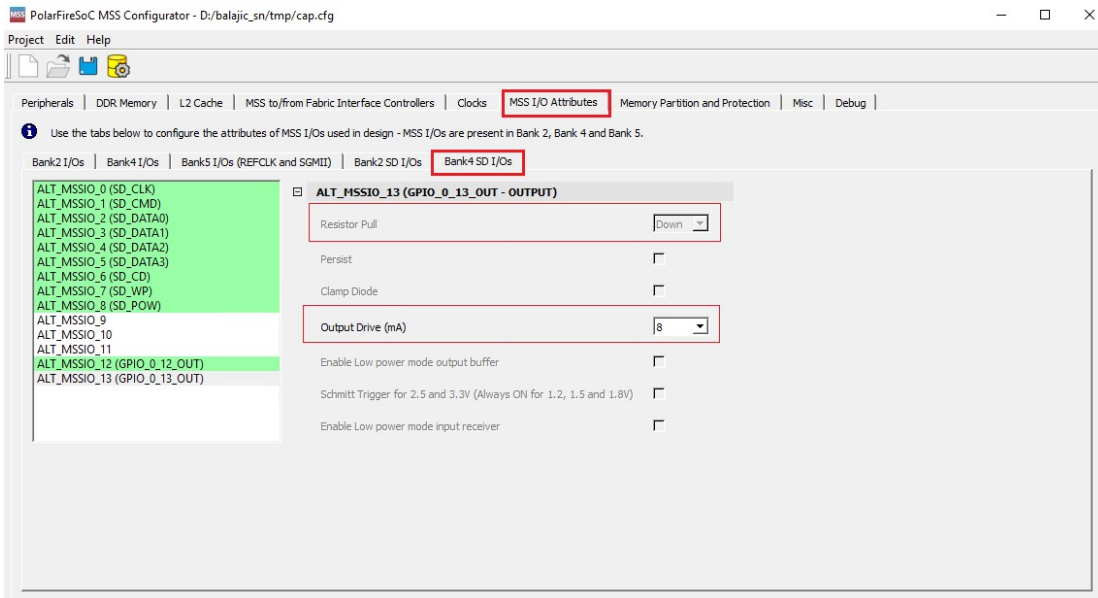

3.3.5 DDR Memory

Select the required DDR type from the **DDR Memory Type** pull-down. The DDR configuration options are available on the **DDR Topology**, **DDR Controller**, **DDR Memory Initialization**, and **DDR Memory Timing** tabs (see the following figure).

For more information about the architecture and functional blocks of MSS DDR Controller, see [PolarFire SoC FPGA MSS Technical Reference Manual](#). This section describes the options available in the **MSS Configurator > DDR Memory** tab for configuring MSS DDR Controller.

The **DDR Topology** tab, in the following figure, controls the physical aspects of the memory, such as data and address widths, enabling of ECC and DM, and setting the clock frequency.

- For DDR3 and DDR4, the COMPONENT, UDIMM, RDIMM, LRDIMM, and SODIMM memory formats are supported.

- For LPDDR3/4, only the COMPONENT memory format is supported.

Figure 3-18. DDR Memory Tab

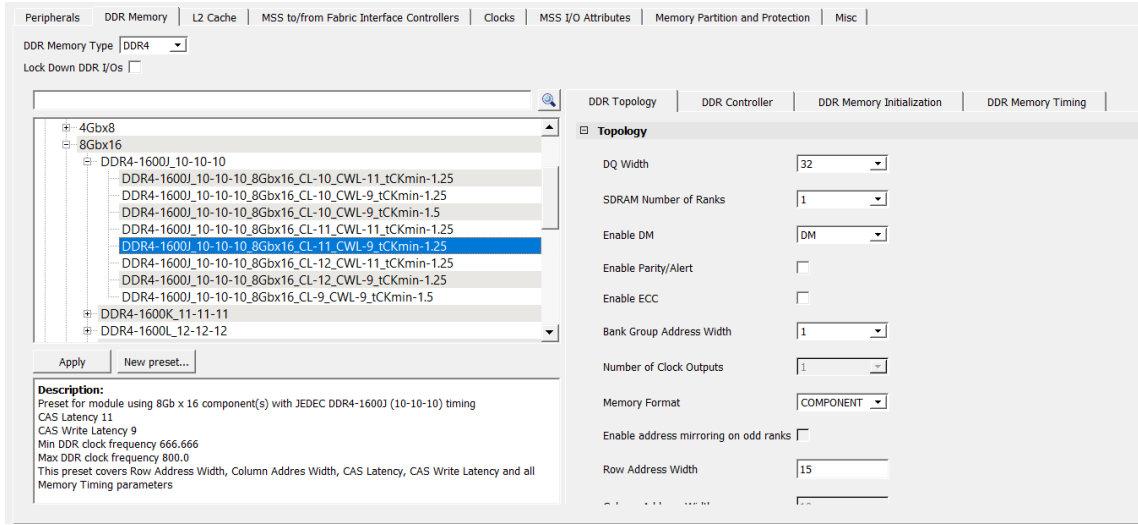

Important:

- Enable the Lock Down DDR I/Os option to lock all the DDR I/Os.
- Configure the DDR parameters according to the data sheet from the DDR vendor.

The **DDR Controller** tab controls the DQS Drive, ODT, Precharge look-ahead, and Address Ordering.

Figure 3-19. DDR Controller Tab

DDR Topology | DDR Controller | **DDR Memory Initialization** | DDR Memory Timing

Drive

DQ Drive 48 DQS Drive 48

ADD/CMD Drive 34 Clock Drive 48

ODT

DQ ODT 120

DQS ODT 120

Efficiency

Enable Activate/Precharge look-ahead

Address Ordering Chip-Row-BG-Bank-Col

ODT Activation Settings on Write

Enable Rank0 - ODT0 Enable Rank0 - ODT1

Enable Rank1 - ODT0 Enable Rank1 - ODT1

ODT Activation Settings on Read

The **DDR Memory Initialization** tab controls the DDR mode register configuration according to the JEDEC specification. In the PolarFire SoC FPGA DDR architecture, these parameters are passed to the start-up code running on the E51 monitor core, which then performs the DDR initialization sequence and configures the mode registers.

The following figure shows the memory initialization configuration.

Figure 3-20. DDR Memory Initialization

DDR Topology	DDR Controller	DDR Memory Initialization	DDR Memory Timing
Mode Register 0			
Burst Length	Fixed BL8		
Read Burst Type	Sequential		
Memory CAS Latency	12		
Mode Register 1			
ODT Rtt Nominal Value	RZQ/4		
Memory Additive CAS Latency	CL-1		
Output Drive Strength	RZQ/7		
Mode Register 2			
Low Power Auto Self Refresh	Automatic		
Memory Write CAS Latency	11		
Dynamic ODT (Rtt_WR)	RZQ/1		
Mode Register 3			

The **DDR Memory Timing** tab controls the timing parameters, which are translated to the appropriate configuration values for the DDR subsystem IP.

Figure 3-21. DDR Memory Timing Tab

DDR Topology	DDR Controller	DDR Memory Initialization	DDR Memory Timing
<input type="checkbox"/> Timing parameters dependent on speed bin			
tRAS (ns)	<input type="text" value="35"/>		
tRCD (ns)	<input type="text" value="15"/>		
tRP (ns)	<input type="text" value="15"/>		
tRC (ns)	<input type="text" value="50"/>		
tWR (ns)	<input type="text" value="15"/>		
tCCD_L (cycles)	<input type="text" value="5"/>		
tCCD_S (cycles)	<input type="text" value="4"/>		
<input type="checkbox"/> Timing parameters dependent on operating condition			
tREFI (us)	<input type="text" value="7.8"/>		
<input type="checkbox"/> Timing parameters dependent on speed bin and page size			
tRFC (ns)	<input type="text" value="160"/>		
tFAW (ns)	<input type="text" value="75"/>		

3.3.6 Misc

Use the **Misc** tab to enable the following options:

- Trace functionality
- JTAG (Debug) functionality
- Interrupts to/from MSS
- Configuring GPIO Interrupt Register
- Exposing Boot Status ports
- Exposing feedback ports to fabric

Figure 3-22. Misc Tab

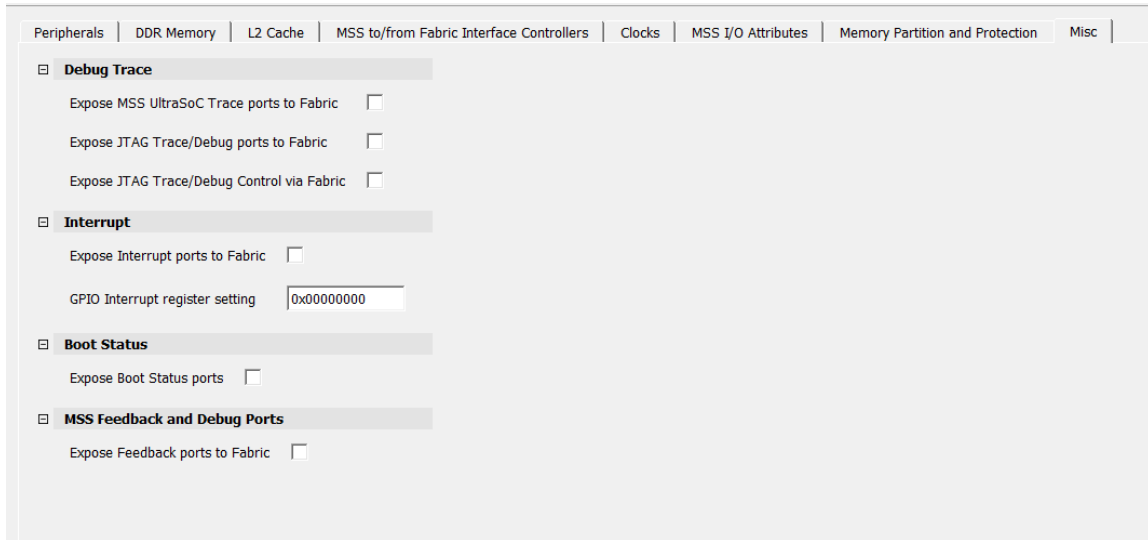

For more information, see [PolarFire SoC FPGA MSS Technical Reference Manual](#).

By default, these options are marked as **Unused**. When any of the options are enabled, the corresponding ports are exposed on the MSS block (see the following figure).

Boot Status: When **Expose Boot Status ports** option is selected, the ports `BOOT_FAIL_CLEAR_F2M` and `BOOT_FAIL_ERROR_M2F` are exposed as shown in the following figure.

Figure 3-23. PFSOC_MSS_C0_0 Jtag Trace Enabled

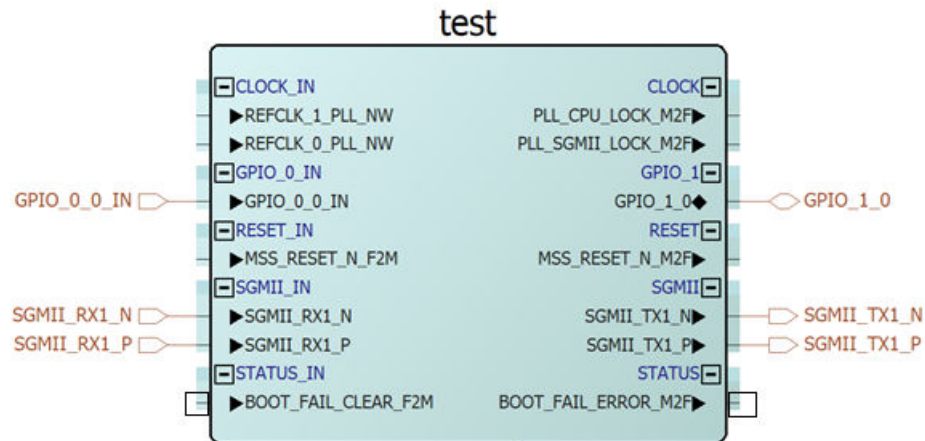

MSS Feedback and Debug Ports: This option is only available for production devices. If selected, a group of `MSS_FEEDBACK_DEBUG` ports are exposed as shown in the following figure.

Figure 3-24. MSS Module With MSS_FEEDBACK_DEBUG Ports Exposed

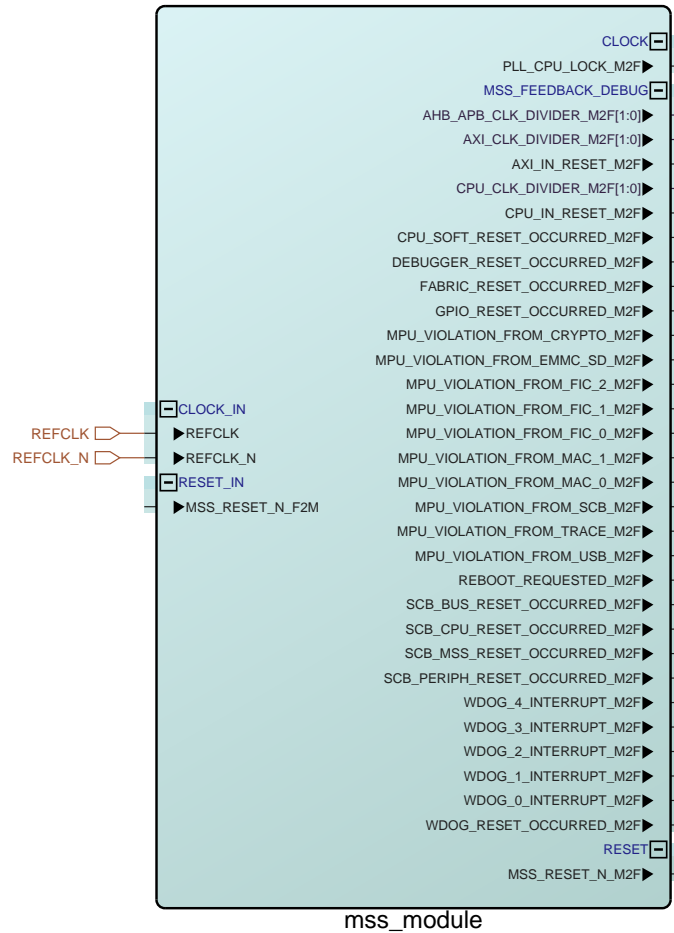

Important: In a Libero project, when System Controller Suspend Mode is enabled (**Project > Project Settings > Device settings**), the `PFSOC_SCSM` macro must be instantiated in the user design and the `REBOOT_REQUESTED_M2F` pin of MSS must be connected to the `SC_WAKE` pin of `PFSOC_SCSM` macro to wake up the system controller temporarily so it can reboot the MSS during normal operation.

3.3.7 L2 Cache

Level2 memory subsystem has three operating modes – Cache, Loosely-Integrated-Memory (LIM), and Scratchpad. These modes can be configured in MSS configurator using the options in the L2 Cache tab based on user needs. The goal is to make the configuration options easier to use and understand for the users.

You can allocate L2 memory for the processor or peripheral using the **L2 Cache** tab, as shown in the following figure.

Figure 3-25. L2 Cache

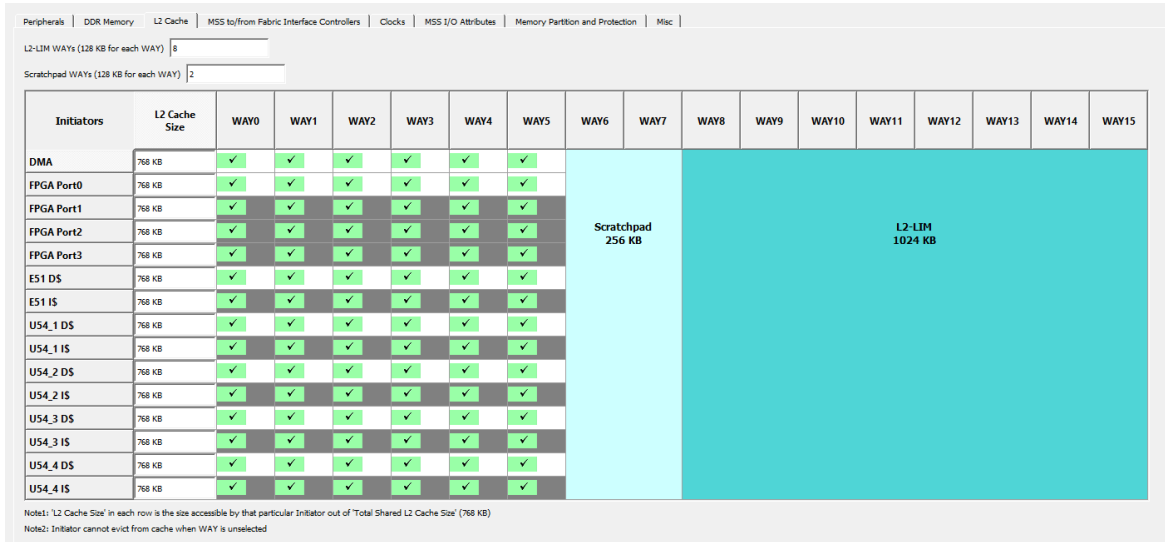

In the L2 Cache tab:

- There are 16 WAYS. WAY0 is always allocated for Cache.
- In the GUI, the default L2-LIM size will be set at 15 (WAY1 – WAY15). This means that 1 WAY (128 Kbytes) is configured as L2 cache and 1920 Kbytes is configured as LIM. User can increase or decrease the L2-LIM size to configure the LIM as Cache memory for various processors and peripherals.
- In the GUI, all the WAYS are enabled for Cache by default. The user can disable the selection to allocate it for Scratchpad.
- Cache size shows the amount of memory available and is shared among all processors and peripherals.



Important:

- All AXI4 front way ports must be identical.
- The core D & I Ways have to be identical and hence ways for port 1, 2, 3, and ways for core I are disabled for selection.

3.3.8 Crypto

The following table lists the crypto ownership modes.

Table 3-8. Crypto Ownership Modes

Owner	Description
MSS	The MSS owns the crypto.
Fabric	The Fabric owns the crypto and ports are exposed to the fabric.
Shared MSS	This is shared between the MSS and the Fabric. The MSS is the first owner. There are regular ports and other ports for handshaking to switch the ownership.
Shared Fabric	This is shared between the MSS and the Fabric. The Fabric is the first owner. There are regular ports and other ports for handshaking and to switch ownership.

Note: Streaming Interface is not available for Fabric mode.

Figure 3-26. Crypto Tab

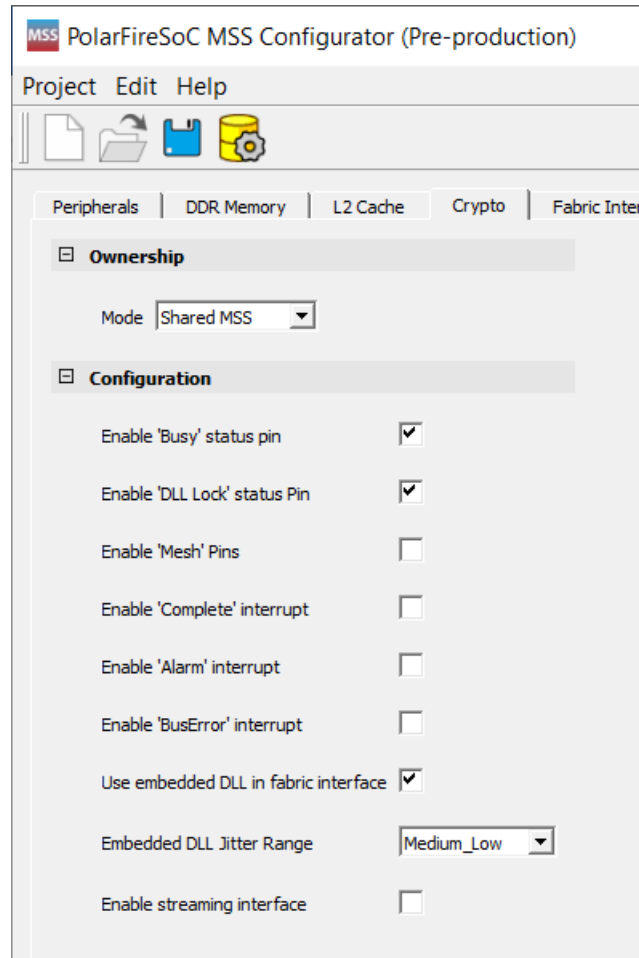

In the crypto modes:

- The status pins and interrupt pins are available as configuration options in all the ownership modes except the MSS ownership mode.
- There are three options that expose the DLL lock, Busy, and Mesh ports. The Busy and DLL Lock are ON by default, while the Mesh input pin connects to 0 when not used.
- The **Use embedded DLL in fabric interface** is always provided in all modes and is enabled by default when the **Enable streaming interface** option is selected.

3.3.9 Memory Partition and Protection

The Physical Memory Protection (PMP) prevents a process (running on a RISC-V Processor) or an initiator (FPGA Fabric) from accessing memory that has not been allocated to it. RISC-V system has PMP unit, which provides control registers for each processor to allow physical memory access privileges (read, write, execute) to be specified for each physical memory region. Similarly, the AXI Switch has Memory Protection Unit (MPU) block which provides register control to setup memory access regions for FPGA initiators.

DDR Memory Partition

The DDR Memory Partition tab allows the DDR memory to be allocated to cached and non-cached regions depending on the amount of DDR memory physically connected.

Figure 3-27. DDR Memory Partition Tab

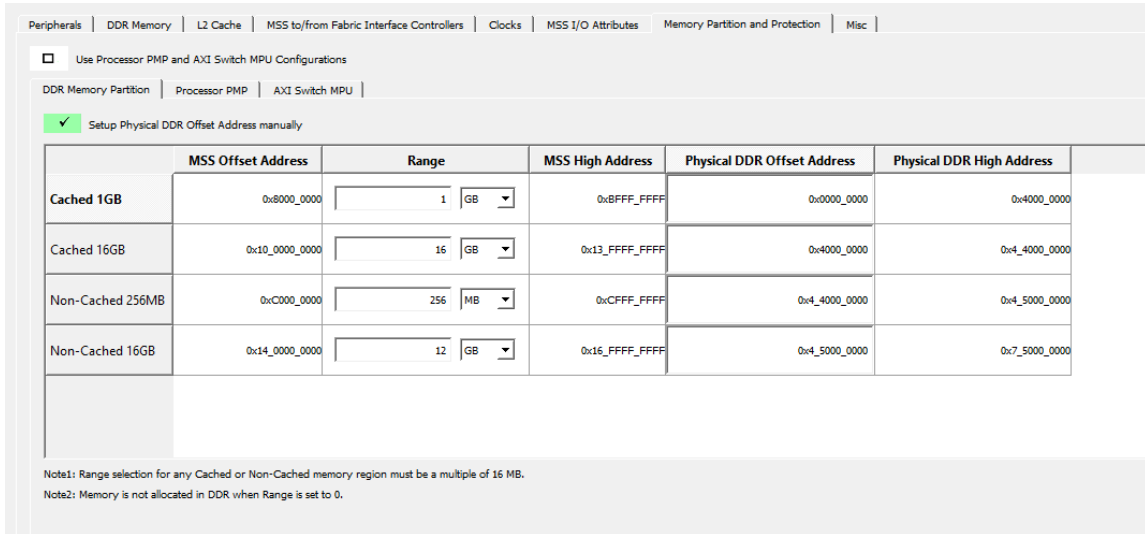

In the DDR Memory Partition:

- The Offset Address (Base Address) for both cached and non-cached regions is fixed.
- High Address is the End Address based on the size.
- Users are expected to enter the Range. Based on the Range selection, High Address and Physical DDR Offset is updated.
 - When Range is set to zero, memory is not allocated in DDR.
 - When Range is set to a nonzero value, it must be a multiple of 16 MB.
- Physical DDR Offset is allocation of DDR memory (connected to the FPGA system) based on the nonzero Range value.



Important: When **Setup Physical DDR Address manually** option is enabled, the default Physical DDR Offset Address is set as 0x0000_0000 for all the regions and it is up to the user to change this address (when the size of the allocated memory region is greater than 0 bytes). When the size of allocated memory region is zero bytes, the offset and high address are reported as **N/A** and remains as a read-only field.

- Range is allocated sequentially starting with 0x0000_0000 in the following order:
 - Cached 32-bit
 - Cached 64-bit
 - Non-Cached 32-bit
 - Non-Cached 64-bit

The following figure shows the graphical representation of how the Physical DDR Offset allocation is done based on the above ranges:

Figure 3-28. Physical DDR Offset - Graphical Representation

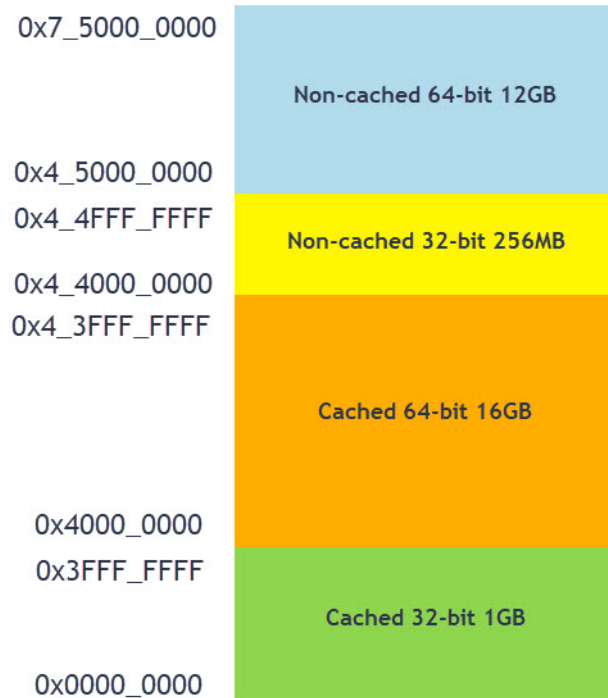

Processor PMP

The following figure shows the Processor PMP tab.

Figure 3-29. Processor PMP Tab

Processor Initiators

	AMP Context A	AMP Context B
US4.1	<input checked="" type="checkbox"/>	<input type="checkbox"/>
US4.2	<input type="checkbox"/>	<input checked="" type="checkbox"/>
US4.3	<input checked="" type="checkbox"/>	<input type="checkbox"/>
US4.4	<input checked="" type="checkbox"/>	<input type="checkbox"/>

Processor Initiators in AMP Context A and AMP Context B can access the Peripherals selected below

	AMP Context A				AMP Context B			
	Enabled	Offset Address	Range	High Address	Enabled	Offset Address	Range	High Address
HHUART_1	<input checked="" type="checkbox"/>	0x2010_0000	4_KB	0x2010_0FFF	<input type="checkbox"/>	0x2010_0000	4_KB	0x2010_0FFF
HHUART_2	<input checked="" type="checkbox"/>	0x2010_2000	4_KB	0x2010_2FFF	<input type="checkbox"/>	0x2010_2000	4_KB	0x2010_2FFF
HHUART_3	<input type="checkbox"/>	0x2010_4000	4_KB	0x2010_4FFF	<input checked="" type="checkbox"/>	0x2010_4000	4_KB	0x2010_4FFF
HHUART_4	<input type="checkbox"/>	0x2010_6000	4_KB	0x2010_6FFF	<input checked="" type="checkbox"/>	0x2010_6000	4_KB	0x2010_6FFF
SPI_0	<input checked="" type="checkbox"/>	0x2010_8000	4_KB	0x2010_8FFF	<input type="checkbox"/>	0x2010_8000	4_KB	0x2010_8FFF
SPI_1	<input type="checkbox"/>	0x2010_9000	4_KB	0x2010_9FFF	<input checked="" type="checkbox"/>	0x2010_9000	4_KB	0x2010_9FFF

Processor Initiators can access memory regions created below (DDR / FPGA Fabric memory through FIC)

Name	Memory Type	AMP Context	Offset Address	Range	High Address	Lock PMP	Read	Write	Execute
DDR_Cached_16GB_0	DDR_Cached_16GB	AMP_Context_A	0x10_0000_0000	4_Bytes	0x10_0000_0003	<input type="checkbox"/>	<input type="checkbox"/>	<input checked="" type="checkbox"/>	<input type="checkbox"/>
FIC_0_S12MB_1	FIC_0_S12MB	AMP_Context_A	0x6000_0000	4_Bytes	0x6000_0003	<input type="checkbox"/>	<input checked="" type="checkbox"/>	<input type="checkbox"/>	<input type="checkbox"/>

Processor Initiators

Four CPU initiators can be enabled in one of the two Asymmetric Multi Processing (AMP) contexts. CPU initiators can access both CPU and Peripherals.

Figure 3-30. Processor Initiators

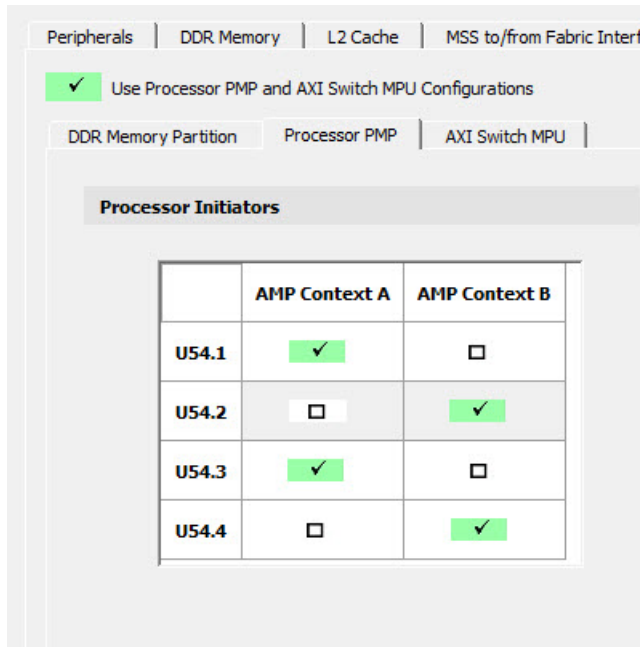

Processor Initiators in Context A and Context B can access the following selected Peripherals

The AMP Context A is assigned to AHB0 bus interface and AMP Context B is assigned to AHB1 bus interface. Peripherals can be enabled in either Context A or in Context B. The range and base address for the peripherals are populated in Graphical User Interface and are not editable. The base address will be different for peripherals that are on dual AHB bus interfaces for Context A and Context B.

Figure 3-31. Processor Initiators in Context A and Context B Accessing the Peripherals

Processor Initiators in AMP Context A and AMP Context B can access the Peripherals selected below

	AMP Context A				AMP Context B			
	Enabled	Offset Address	Range	High Address	Enabled	Offset Address	Range	High Address
MMUART_1	<input checked="" type="checkbox"/>	0x2010_0000	4_KB	0x2010_0FFF	<input type="checkbox"/>	0x2810_0000	4_KB	0x2810_0FFF
MMUART_2	<input type="checkbox"/>	0x2010_2000	4_KB	0x2010_2FFF	<input checked="" type="checkbox"/>	0x2810_2000	4_KB	0x2810_2FFF
MMUART_3	<input checked="" type="checkbox"/>	0x2010_4000	4_KB	0x2010_4FFF	<input type="checkbox"/>	0x2810_4000	4_KB	0x2810_4FFF
MMUART_4	<input type="checkbox"/>	0x2010_6000	4_KB	0x2010_6FFF	<input checked="" type="checkbox"/>	0x2810_6000	4_KB	0x2810_6FFF
SPI_0	<input checked="" type="checkbox"/>	0x2010_8000	4_KB	0x2010_8FFF	<input type="checkbox"/>	0x2810_8000	4_KB	0x2810_8FFF
SPI_1	<input type="checkbox"/>	0x2010_9000	4_KB	0x2010_9FFF	<input checked="" type="checkbox"/>	0x2810_9000	4_KB	0x2810_9FFF
I2C_0	<input checked="" type="checkbox"/>	0x2010_A000	4_KB	0x2010_AFFF	<input type="checkbox"/>	0x2810_A000	4_KB	0x2810_AFFF
I2C_1	<input type="checkbox"/>	0x2010_B000	4_KB	0x2010_BFFF	<input checked="" type="checkbox"/>	0x2810_B000	4_KB	0x2810_BFFF
CAN_0	<input checked="" type="checkbox"/>	0x2010_C000	4_KB	0x2010_CFFF	<input type="checkbox"/>	0x2810_C000	4_KB	0x2810_CFFF
CAN_1	<input type="checkbox"/>	0x2010_D000	4_KB	0x2010_DFFF	<input checked="" type="checkbox"/>	0x2810_D000	4_KB	0x2810_DFFF
Gigabit Ethernet MAC_0	<input checked="" type="checkbox"/>	0x2011_0000	8_KB	0x2011_1FFF	<input type="checkbox"/>	0x2811_0000	8_KB	0x2811_1FFF
Gigabit Ethernet MAC_1	<input type="checkbox"/>	0x2011_2000	8_KB	0x2011_3FFF	<input checked="" type="checkbox"/>	0x2811_2000	8_KB	0x2811_3FFF
GPIO_0 (Bank4 I/Os)	<input checked="" type="checkbox"/>	0x2012_0000	4_KB	0x2012_0FFF	<input type="checkbox"/>	0x2812_0000	4_KB	0x2812_0FFF
GPIO_1 (Bank2 I/Os)	<input type="checkbox"/>	0x2012_1000	4_KB	0x2012_1FFF	<input checked="" type="checkbox"/>	0x2812_1000	4_KB	0x2812_1FFF
GPIO_2 (Fabric)	<input checked="" type="checkbox"/>	0x2012_2000	4_KB	0x2012_2FFF	<input type="checkbox"/>	0x2812_2000	4_KB	0x2812_2FFF

Processor Initiators can access memory regions created below (DDR/FPGA Fabric memory through FICs)

DDR memory appears at several address ranges depending on whether it is cached, non-cached, or access through a Write Combine Buffer (WCB). WCB improves performance (by combining multiple writes to the same address into

a single write) for sequential accesses. Each AMP context needs to specify how much DDR memory of each type it needs. Some DDR memories may be shared between AMP Context to pass data. User can create protection for memory region accessed by processors by clicking on the **Add Memory Region...** button. User can delete any memory region by selecting the memory region and clicking **Delete** button. The following figure shows the memory regions available to Processor Initiators.

Figure 3-32. Memory Regions Available to Processor Initiators

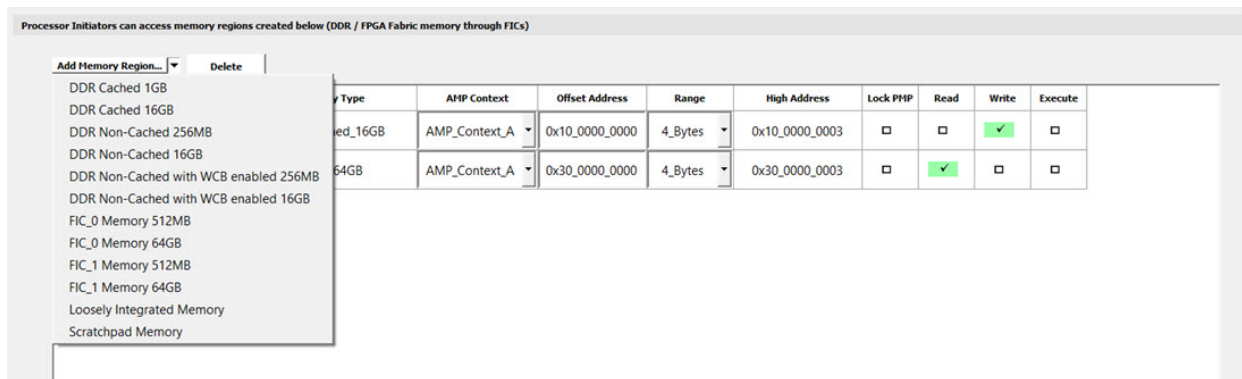

The following table lists different types of memory regions that user can create.

Table 3-9. Available Memory Region

Memory Type	Memory Size	Address Size	Address Range
DDR Cached	512 MB	32-bit	0x80000000 - 0xBFFFFFFF
	16 GB	64-bit	0x10_00000000 - 0x13_FFFFFFFF
DDR Non-Cached	256 MB	32-bit	0xC0000000 - 0xCFFFFFFF
	16 GB	64-bit	0x14_00000000 - 0x17_FFFFFFFF
DDR Non-Cached with WCB enabled	256 MB	32-bit	0xC0000000 - 0xCFFFFFFF
	16 GB	64-bit	0x14_00000000 - 0x17_FFFFFFFF
FIC_0 Memory	512 MB	32-bit	0x60000000 - 0x7FFFFFFF
	64 GB	64-bit	0x20_00000000 - 0x2F_FFFFFFFF
FIC_1 Memory	512 MB	32-bit	0xE0000000 - 0xFFFFFFFF
	64 GB	64-bit	0x30_00000000 - 0x3F_FFFFFFFF
Loosely Integrated Memory	—	—	Start Address is 0x0800_0000
Scratch	—	—	Start Address is 0x0A00_0000

AXI Switch MPU

AXI switch Memory Protection Unit (MPU) provides FPGA (Non-CPU) Initiators read/write/execute access to the Memory subsystem and Fabric Memory. Users can create protection for memory regions accessed by FPGA Initiators by clicking any one of the FPGA Initiators and clicking the **Add Memory Region...** button. User can delete any memory region by selecting the memory region and clicking **Delete** button.

Libero® SoC v2022.3

Running the PolarFire SoC MSS Configurator

Figure 3-33. AXI Switch MPU Tab

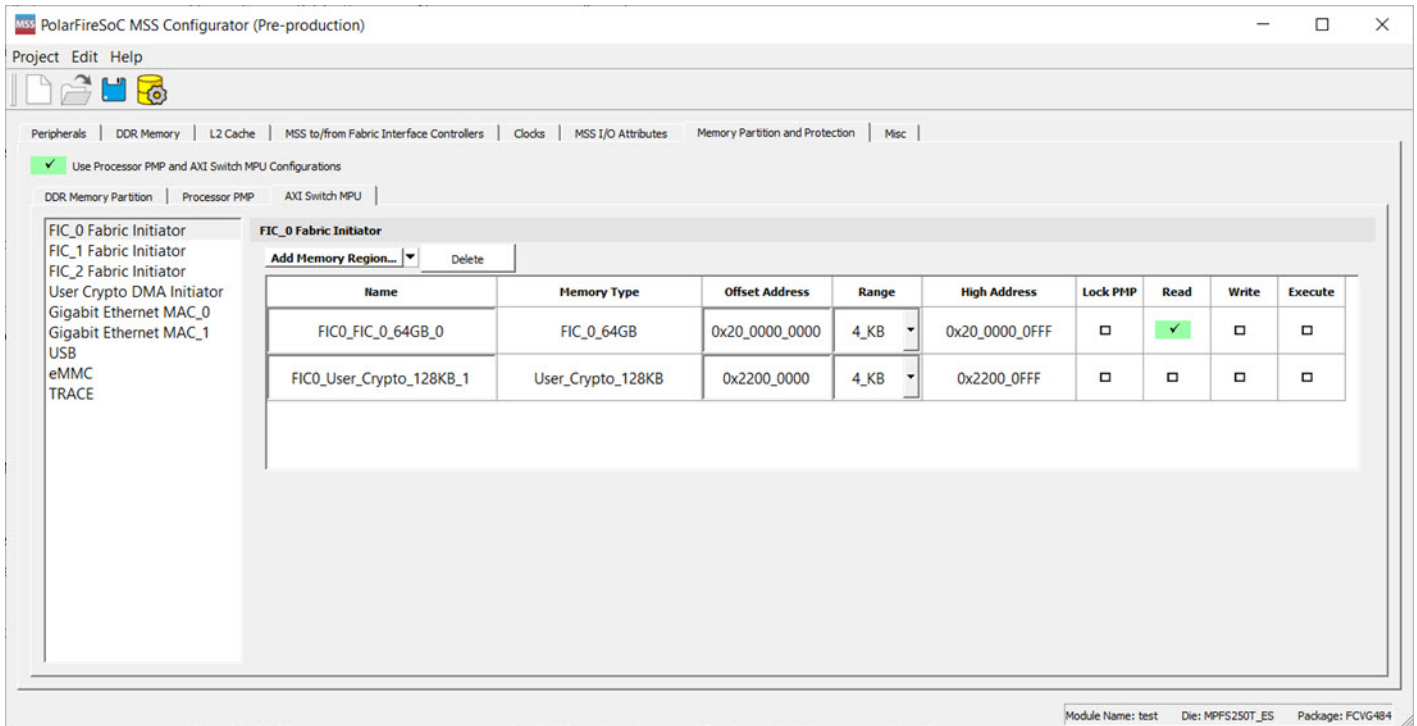

The following table lists the different types of memory regions that user can create.

Memory Type	Memory Size	Address Size	Address Range
DDR Non-Cached	256 MB	32-bit	0xC0000000 - 0xCFFFFFFF
	16 GB	64-bit	0x14_00000000 - 0x17_FFFFFFFF
FIC_0 Memory	512 MB	32-bit	0x60000000 - 0x7FFFFFFF
	64 GB	64-bit	0x20_00000000 - 0x2F_FFFFFFFF
FIC_1 Memory	512 MB	32-bit	0xE0000000 - 0xFFFFFFFF
	64 GB	64-bit	0x30_00000000 - 0x3F_FFFFFFFF
FIC_3 Memory	512 MB	32-bit	0x40000000 - 0x5FFFFFFF
User Crypto Memory	128 KB	32-bit	0x22000000 - 0x2201FFFF

4. Creating a Project and Configuring MSS

To create a project and configure MSS:

1. Launch the PolarFire SoC MSS Configurator (`pf_soc_mss`) using one of the following ways:
 - Libero SoC installation directory
 - Standalone MSS installation area
 - Windows Start menu
2. Create a new project using **Project > New**.
3. Enter a module name (for example, `PFSOC_MSS_C0`), and then select the appropriate die, package, and speed. The module name you enter appears in the following places:
 - File names of the PolarFire SoC MSS Configurator generated outputs at the specified output/generation directory
 - MSS component file (`<module_name>.cxz`)
 - MSS XML configuration file (`<module_name>_mss_cfg.xml`)
 - MSS configuration file corresponding to the current MSS configuration that is generated (`<module_name>.cfg`)
 - MSS configuration report file (`<module_name>_Report.html`)
 - Component/module name of the MSS component (`cxz`) that can be imported to a Libero SoC project

Figure 4-1. MSS - Module Name Dialog Box

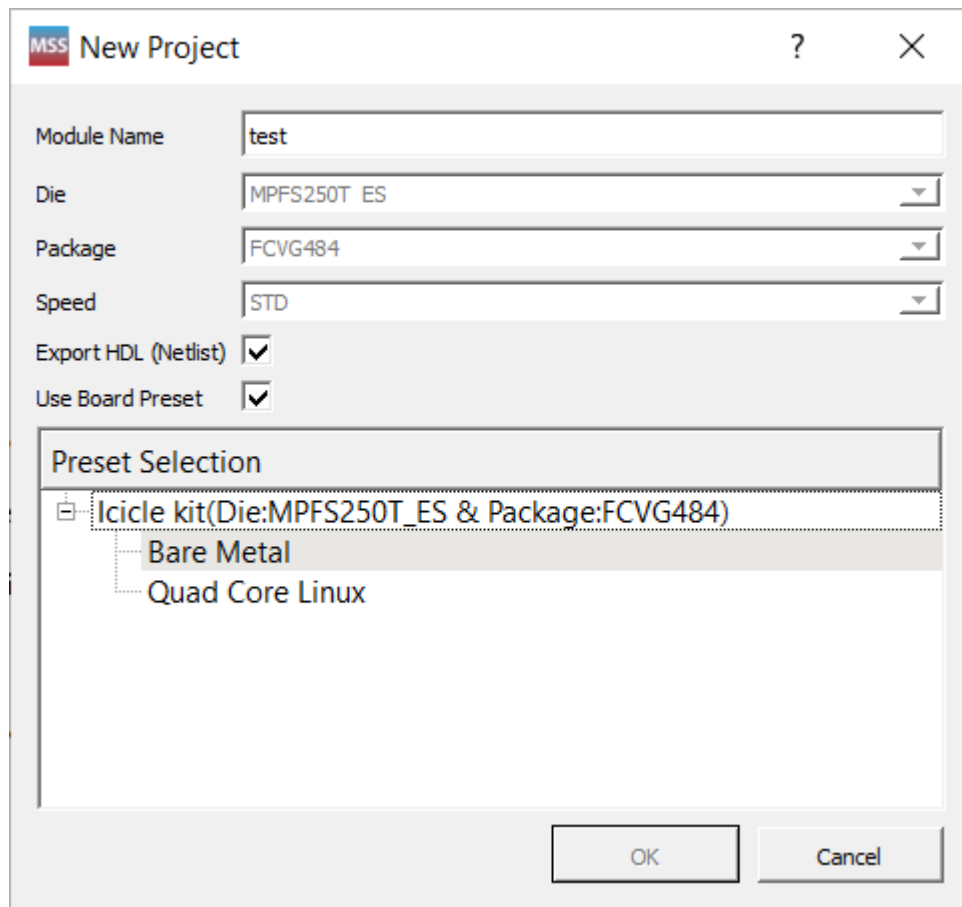

Presets for Icicle Kit

When you create a New Project, you can import one of the available presets for Icycle kit. These presets are staged in data folder and are in 'CFG' format. All the parameter/values from the CFG file are loaded, except for the following four parameters:

- Module Name
- Die
- Package
- Speed

User-selected values are used for Module Name, Die, Package, and Speed parameters in the GUI. This is done to facilitate changing Module Name/Die/Package/Speed (from the Icycle kit preset) to meet users need.

The default speed grade is STD including for the Icycle Kits. If you open a previous release .cfg, which does not have speed grade (PolarFire SoC MSS Configurator v2021.2 or earlier) in v2021.3, it has STD as the default speed grade.

The list of presets are shown using a tree widget. By default, the 'Default Configuration' preset is selected in GUI and user must explicitly select one of the presets for Icycle kit to load them. Once a preset is selected, users cannot edit them using **Edit Settings** option as the preset tree widget is unavailable in the **Edit Settings** dialog box.

The following figure shows the MSS configurator tabs.

Figure 4-2. MSS Configurator Tabs

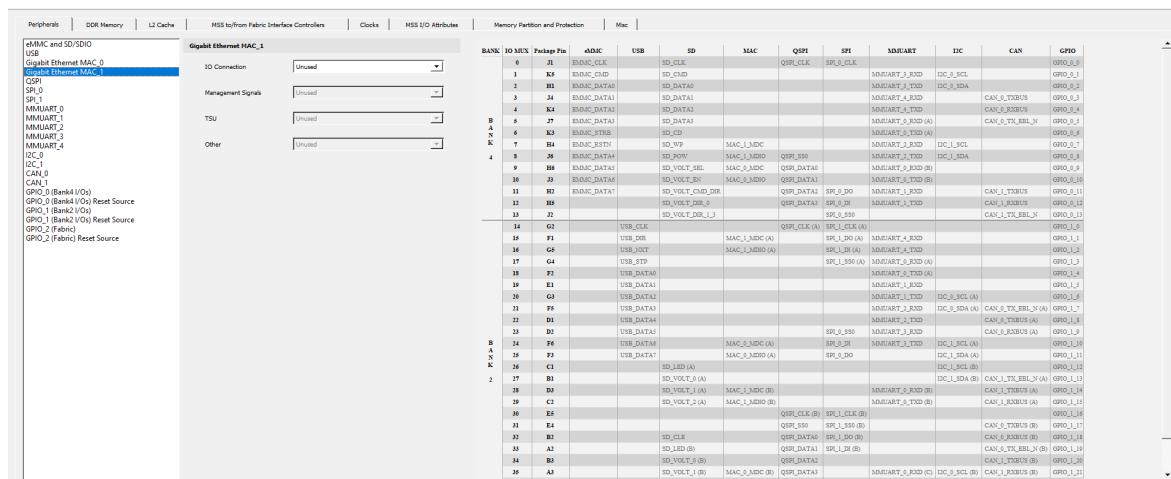

4. Configure **Clocks, Fabric Interface Controllers, I/O Configuration, DDR Memory, and Misc settings.**
5. Click the **Save** option to save the MSS configuration to a .cfg file.
6. From the **Save MSS Configuration** dialog box:
 - Browse to a directory and create a folder. For example, create C:\Microsemi\PFSoC_MSS_Configuration.
 - Enter a file name (for example, PFSoC_MSS_C0) and click **Save**.

Note: The file name you enter is for the stand-alone MSS project only and is not used as the component name.

The MSS Configuration is created and saved to the file specified and the Log window shows the following message:
 INFO: Successfully saved MSS configuration in C:/Microsemi/PFSoC_MSS_Configuration/PFSoC_MSS_C0.cfg file.

5. Generating, Importing, and Exporting the MSS Component

The following sections describe the steps for generating, importing, and exporting the MSS component.

5.1 Generating the MSS Component and Report

To generate the MSS component, use the **Generate** option (see the following figure).

Figure 5-1. Generate Option

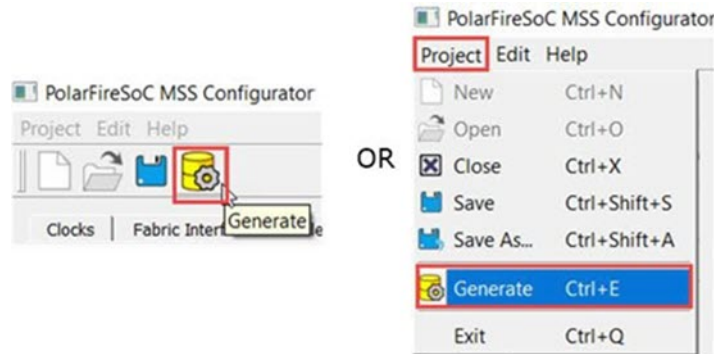

The configuration file (`module_name.xml`) required for the firmware project and the configuration report file (`module_name.html`) are also generated at this time.

The Log window shows the following messages indicating the generated files:

```
INFO: Successfully generated MSS configuration report to 'C:/Microsemi/PFSOC_MSS_Configuration/PFSOC_MSS_C0_Report.html'
```

```
INFO: Successfully generated MSS component file to 'C:/Microsemi/PFSOC_MSS_Configuration/PFSOC_MSS_C0.cxz'
```

The report file (`module_name.html`) consists of following sections:

- Design Information – This section consists of design parameters like device family name, die, package, configurator version, and the date the report was generated.
- FPGA Fabric – This section mentions whether FPGA Fabric programming is required or not.
- Fabric Interface Controllers – Consists information about status of the interface controllers.
- Peripherals – Contains information about which peripherals are being used or unused.
- DDR Memory – Shows the memory type.
- List of Ports – Depicts information about all the ports with direction.
- I/O REFCLK Port Settings – Shows all the information about Reference clock ports.
- MSSIO Port Settings – Shows all the information about MSSIO ports.
- DDRIO Port Settings – Shows all the information about DDRIO ports.
- SGMII I/O Port Settings – Shows all the information about SGMII ports.

Figure 5-2. Configuration Report for PolarFire SoC MSS Configurator

Design Information

Design Parameter Name	Design Parameter Value
Family	PolarFireSoC
Die	MPFS250T_ES
Package	FCVG484
Version	2021.3
Date	Wed Nov 10 11:06:25 2021

FPGA Fabric

FPGA Fabric Programming	Required
--------------------------------	-----------------

MSS to/from Fabric Interface Controllers

Interface Controller Name	Enabled
FIC_0 AXI4 Initiator Interface	true
FIC_0 AXI4 Target Interface	true
FIC_1 AXI4 Initiator Interface	false
FIC_1 AXI4 Target Interface	true
FIC_2 AXI4 Target Interface	true
FIC_3 APB Initiator Interface	true

Peripherals

Peripheral Name	Enabled
eMMC	MSSIO_B4
USB	MSSIO_B2
SD/SDIO	MSSIO_B4
Gigabit Ethernet MAC_0	SGMII_IO_B5
Gigabit Ethernet MAC_1	SGMII_IO_B5
QSPI	MSSIO_B2
SPI_0	FABRIC
SPI_1	UNUSED
MMUART_0	FABRIC
MMUART_1	FABRIC
MMUART_2	FABRIC
MMUART_3	FABRIC
MMUART_4	FABRIC
I2C_0	FABRIC
I2C_1	MSSIO_B2_B
CAN_0	FABRIC
CAN_1	MSSIO_B2_B
GPIO_0_0	UNUSED
GPIO_0_1	UNUSED
GPIO_0_2	UNUSED
GPIO_0_3	UNUSED
GPIO_0_4	UNUSED
GPIO_0_5	UNUSED

5.2 Importing the MSS CXZ File to Libero SoC

To import the PFSOC_MSS_C0.cxz file:

1. Use the **Import MSS** option shown in the following figure.

Figure 5-3. Import MSS to Libero

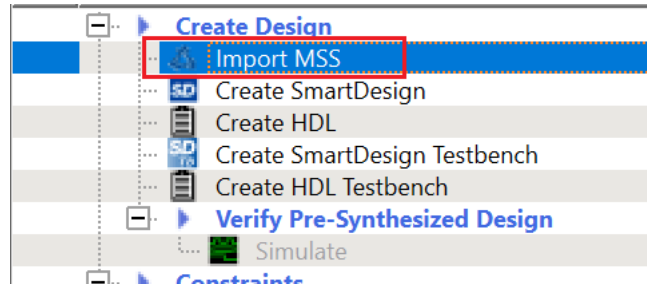

2. From Design Hierarchy, drag the MSS component to SmartDesign canvas.
3. Build the hierarchy.

Note: Any changes required in the MSS configuration must be performed in the PolarFire SoC MSS Configurator, and the updated MSS CXZ file must be re-imported and used in Libero SmartDesign.

5.3 Importing the MSS XML File to SoftConsole

Copy the XML file from:

```
<$Directory>:\Microsemi\PFSOC_MSS_Configuration\PFSOC_MSS_C0_mss_cfg.xml
```

to:

```
<$Installation  
Directory>:\Microchip\<$SoftConsole_Workspace>\Project_Name\src\platform\config\xml
```

Note: This step can also be performed using the **Import** option from SoftConsole.

5.4 Exporting the FPGA Design Hardware Platform Information

When using PolarFire SoC, the overall application runs an embedded software application on the RISC-V cores that may use the FPGA fabric to expand the number of I/O peripherals, accelerate software functions using FPGA logic, or control FPGA fabric functions. In these cases, the processor communicates with the FPGA fabric via the MSS Fabric Interface Controllers (FIC) and interrupt ports. The embedded software application must contain the following information to establish this communication properly:

- Fabric blocks like LSRAM, DMA Controller, and PCIe are connected to the AXI interconnect IP on the Fabric side. MSS communicates with these fabric blocks via Fabric Interface Controllers, which connects to the AXI Interconnect IP. The memory addresses of these fabric blocks are specified in the AXI Interconnect IP Configurator. These memory addresses must be specified in the software application.
- In the Libero SoC design, the user must drive the required MSS interrupt ports and other interrupts can be grounded. The corresponding Interrupt Request (IRQ) handler routines must be invoked in the software application for interrupt handling.

Libero SoC tool does not export the FPGA fabric peripheral memory map, interrupt mapping, or peripheral clock frequencies. Therefore, add this information manually in your embedded software projects. For example, if fabric blocks such as LSRAM and DMA Controller are used in the design and interfaced with the MSS through a FIC, then the memory addresses of these fabric blocks must be specified in the user application code for accessing them from MSS.

6. Simulating an FPGA Design Interacting with MSS

The MSS simulation model has been designed to verify that the connectivity to the MSS has been properly established with the FPGA fabric logic.

The MSS simulation model can be used to verify:

- The Fabric—MSS connectivity using the Fabric Interface Controllers (FICs).
- The Fabric—MSS interrupt (M2F and F2M) interface.

For information about how to set up and run the simulation for the PolarFire SoC MSS, see [MSS Simulation User Guide for PolarFire SoC](#)

7. Programming the Application Bitstream

To program the application bit stream:

1. Use Libero SoC or FlashProExpress to program the FPGA fabric array, sNVM, eNVM and any security settings.
2. Use Libero SoC to program any eNVM client.

Note: SoftConsole must be used to program the Boot mode.

Alternatively, you can also perform the following steps:

1. Use SoftConsole to program the eNVM with the First Stage Boot image.
 - a. Select the project you want programmed to eNVM in SoftConsole's **Project Explorer** pane.
 - b. Click the **PolarFire SoC Boot Mode 1** external tool.

Programming progress messages appear in the Console.

For more information, see [PolarFire SoC Software Development and Tool Flow User Guide](#).

8. Sample Project

For PolarFire SoC Icicle Kit reference design and supporting files, see [PolarFire SoC Icicle Kit Reference Design](#) GitHub repository.

9. Revision History

The revision history describes the changes that were implemented in the document. The changes are listed by revision, starting with the most current publication.

Revision	Date	Description
J	12/2022	<ul style="list-style-type: none"> Updated section 3.3.2. MSS To/From Fabric Interface Controllers. Updated section 3.3.3. Peripherals. Updated section 3.3.4.1. Bank2 I/Os. Updated section 3.3.4.2. Bank4 I/Os. Updated section 3.3.4.3. Bank5 I/Os (REFCLK and SGMII). Updated section 3.3.4.4. Bank2 and Bank4 I/Os Related to SD and eMMC Muxing. Updated section 3.3.5. DDR Memory. Updated section 3.3.6. Misc. Updated section 3.3.7. L2 Cache. Updated section 3.3.9. Memory Partition and Protection. Updated section 4. Creating a Project and Configuring MSS.
H	08/2022	<p>The following list of changes are made in this revision.</p> <ul style="list-style-type: none"> Updated the 3.1. Batch Mode section. Updated the 3.2. Interactive Mode section. Updated the 3.3.4.1. Bank2 I/Os section. Updated the 5.1. Generating the MSS Component and Report section.
G	04/2022	<p>The following list of changes are made in this revision.</p> <ul style="list-style-type: none"> Updated 3.3.1. Clocks with support for -1 speed grade devices. Added information related to Feedback ports in 3.3.6. Misc.
F	12/2021	<p>The following list of changes are made in this revision.</p> <ul style="list-style-type: none"> Updated 4. Creating a Project and Configuring MSS. Removed note from 3.1. Batch Mode. Added information related to Locked Down I/Os in 3.3.6. Misc.
E	08/2021	<p>The following list of changes are made in this revision.</p> <ul style="list-style-type: none"> 1. References: Updated the MSS Fabric Interface Controller features reference.
D	08/2021	<p>The following list of changes are made in this revision.</p> <ul style="list-style-type: none"> 3.3.1. Clocks: Updated the Clocks Tab with addition of eMMC/SD/SDIO and CAN clock sources. 3.3.2. MSS To/From Fabric Interface Controllers: Fabric Interface Controller tab was renamed to 'MSS to/from Fabric Interface Controllers'. 3.3.3. Peripherals: Added information about eMMC or SD/SDIO setting. 3.3.4. MSS I/O Attributes: MSS REFCLK I/O, Bank4 and Bank2 I/Os and SGMII I/Os were moved to MSS I/O Attributes. 3.3.6. Misc: Updated the section with Feedback Ports option.
C	04/2021	<p>The following list of changes are made in this revision.</p> <ul style="list-style-type: none"> Peripherals: Added note related to the availability of SD pins. Crypto: Updated the section with Streaming Interface Option details. Memory Partition and Protection: Added this section.

.....continued

Revision	Date	Description
B	12/2020	Revision B is released in December 2020. Following is a list of changes made in this revision: <ul style="list-style-type: none">• Updated the Using the PolarFire SoC MSS Configurator GUI section.• Updated the Creating a Project and Configuring MSS section.• Updated the Generating the MSS Component and Report section.• Updated the Clocks section.• Added a note in the SGMII section.
A	9/2020	Initial Revision

Microchip FPGA Support

Microchip FPGA products group backs its products with various support services, including Customer Service, Customer Technical Support Center, a website, and worldwide sales offices. Customers are suggested to visit Microchip online resources prior to contacting support as it is very likely that their queries have been already answered.

Contact Technical Support Center through the website at www.microchip.com/support. Mention the FPGA Device Part number, select appropriate case category, and upload design files while creating a technical support case.

Contact Customer Service for non-technical product support, such as product pricing, product upgrades, update information, order status, and authorization.

- From North America, call **800.262.1060**
- From the rest of the world, call **650.318.4460**
- Fax, from anywhere in the world, **650.318.8044**

Microchip Information

The Microchip Website

Microchip provides online support via our website at www.microchip.com/. This website is used to make files and information easily available to customers. Some of the content available includes:

- **Product Support** – Data sheets and errata, application notes and sample programs, design resources, user's guides and hardware support documents, latest software releases and archived software
- **General Technical Support** – Frequently Asked Questions (FAQs), technical support requests, online discussion groups, Microchip design partner program member listing
- **Business of Microchip** – Product selector and ordering guides, latest Microchip press releases, listing of seminars and events, listings of Microchip sales offices, distributors and factory representatives

Product Change Notification Service

Microchip's product change notification service helps keep customers current on Microchip products. Subscribers will receive email notification whenever there are changes, updates, revisions or errata related to a specified product family or development tool of interest.

To register, go to www.microchip.com/pcn and follow the registration instructions.

Customer Support

Users of Microchip products can receive assistance through several channels:

- Distributor or Representative
- Local Sales Office
- Embedded Solutions Engineer (ESE)
- Technical Support

Customers should contact their distributor, representative or ESE for support. Local sales offices are also available to help customers. A listing of sales offices and locations is included in this document.

Technical support is available through the website at: www.microchip.com/support

Microchip Devices Code Protection Feature

Note the following details of the code protection feature on Microchip products:

- Microchip products meet the specifications contained in their particular Microchip Data Sheet.
- Microchip believes that its family of products is secure when used in the intended manner, within operating specifications, and under normal conditions.
- Microchip values and aggressively protects its intellectual property rights. Attempts to breach the code protection features of Microchip product is strictly prohibited and may violate the Digital Millennium Copyright Act.
- Neither Microchip nor any other semiconductor manufacturer can guarantee the security of its code. Code protection does not mean that we are guaranteeing the product is “unbreakable”. Code protection is constantly evolving. Microchip is committed to continuously improving the code protection features of our products.

Legal Notice

This publication and the information herein may be used only with Microchip products, including to design, test, and integrate Microchip products with your application. Use of this information in any other manner violates these terms. Information regarding device applications is provided only for your convenience and may be superseded by updates. It is your responsibility to ensure that your application meets with your specifications. Contact your local Microchip sales office for additional support or, obtain additional support at www.microchip.com/en-us/support/design-help/client-support-services.

THIS INFORMATION IS PROVIDED BY MICROCHIP "AS IS". MICROCHIP MAKES NO REPRESENTATIONS OR WARRANTIES OF ANY KIND WHETHER EXPRESS OR IMPLIED, WRITTEN OR ORAL, STATUTORY OR OTHERWISE, RELATED TO THE INFORMATION INCLUDING BUT NOT LIMITED TO ANY IMPLIED WARRANTIES OF NON-INFRINGEMENT, MERCHANTABILITY, AND FITNESS FOR A PARTICULAR PURPOSE, OR WARRANTIES RELATED TO ITS CONDITION, QUALITY, OR PERFORMANCE.

IN NO EVENT WILL MICROCHIP BE LIABLE FOR ANY INDIRECT, SPECIAL, PUNITIVE, INCIDENTAL, OR CONSEQUENTIAL LOSS, DAMAGE, COST, OR EXPENSE OF ANY KIND WHATSOEVER RELATED TO THE INFORMATION OR ITS USE, HOWEVER CAUSED, EVEN IF MICROCHIP HAS BEEN ADVISED OF THE POSSIBILITY OR THE DAMAGES ARE FORESEEABLE. TO THE FULLEST EXTENT ALLOWED BY LAW, MICROCHIP'S TOTAL LIABILITY ON ALL CLAIMS IN ANY WAY RELATED TO THE INFORMATION OR ITS USE WILL NOT EXCEED THE AMOUNT OF FEES, IF ANY, THAT YOU HAVE PAID DIRECTLY TO MICROCHIP FOR THE INFORMATION.

Use of Microchip devices in life support and/or safety applications is entirely at the buyer's risk, and the buyer agrees to defend, indemnify and hold harmless Microchip from any and all damages, claims, suits, or expenses resulting from such use. No licenses are conveyed, implicitly or otherwise, under any Microchip intellectual property rights unless otherwise stated.

Trademarks

The Microchip name and logo, the Microchip logo, Adaptec, AVR, AVR logo, AVR Freaks, BesTime, BitCloud, CryptoMemory, CryptoRF, dsPIC, flexPWR, HELDO, IGLOO, JukeBlox, KeeLoq, Kleer, LANCheck, LinkMD, maXStylus, maXTouch, MediaLB, megaAVR, Microsemi, Microsemi logo, MOST, MOST logo, MPLAB, OptoLyzer, PIC, picoPower, PICSTART, PIC32 logo, PolarFire, Prochip Designer, QTouch, SAM-BA, SenGenuity, SpyNIC, SST, SST Logo, SuperFlash, Symmetricom, SyncServer, Tachyon, TimeSource, tinyAVR, UNI/O, Vectron, and XMEGA are registered trademarks of Microchip Technology Incorporated in the U.S.A. and other countries.

AgileSwitch, APT, ClockWorks, The Embedded Control Solutions Company, EtherSynch, Flashtec, Hyper Speed Control, HyperLight Load, Libero, motorBench, mTouch, Powermite 3, Precision Edge, ProASIC, ProASIC Plus, ProASIC Plus logo, Quiet- Wire, SmartFusion, SyncWorld, Temux, TimeCesium, TimeHub, TimePictra, TimeProvider, TrueTime, and ZL are registered trademarks of Microchip Technology Incorporated in the U.S.A.

Adjacent Key Suppression, AKS, Analog-for-the-Digital Age, Any Capacitor, AnyIn, AnyOut, Augmented Switching, BlueSky, BodyCom, Clockstudio, CodeGuard, CryptoAuthentication, CryptoAutomotive, CryptoCompanion, CryptoController, dsPICDEM, dsPICDEM.net, Dynamic Average Matching, ICSP, INICnet, Intelligent Paralleling, IntelliMOS, EtherGREEN, GridTime, IdealBridge, In-Circuit Serial Programming, ICSP, INICnet, Intelligent Paralleling, IntelliMOS, Inter-Chip Connectivity, JitterBlocker, Knob-on-Display, KoD, maxCrypto, maxView, memBrain, Mindi, MiWi, MPASM, MPF, MPLAB Certified logo, MPLIB, MPLINK, MultiTRAK, NetDetach, Omniscient Code Generation, PICDEM, PICDEM.net, PICkit, PICTail, PowerSmart, PureSilicon, QMatrix, REAL ICE, Ripple Blocker, RTAX, RTG4, SAM-

ICE, Serial Quad I/O, simpleMAP, SimpliPHY, SmartBuffer, SmartHLS, SMART-I.S., storClad, SQI, SuperSwitcher, SuperSwitcher II, Switchtec, SynchroPHY, Total Endurance, Trusted Time, TSHARC, USBCheck, VariSense, VectorBlox, VeriPHY, ViewSpan, WiperLock, XpressConnect, and ZENA are trademarks of Microchip Technology Incorporated in the U.S.A. and other countries.

SQTP is a service mark of Microchip Technology Incorporated in the U.S.A.

The Adaptec logo, Frequency on Demand, Silicon Storage Technology, and Symmcom are registered trademarks of Microchip Technology Inc. in other countries.

GestIC is a registered trademark of Microchip Technology Germany II GmbH & Co. KG, a subsidiary of Microchip Technology Inc., in other countries.

All other trademarks mentioned herein are property of their respective companies.

© 2022, Microchip Technology Incorporated and its subsidiaries. All Rights Reserved.

ISBN: 978-1-6683-1610-8

Quality Management System

For information regarding Microchip's Quality Management Systems, please visit www.microchip.com/quality.

Worldwide Sales and Service

AMERICAS	ASIA/PACIFIC	ASIA/PACIFIC	EUROPE
<p>Corporate Office 2355 West Chandler Blvd. Chandler, AZ 85224-6199 Tel: 480-792-7200 Tel: 480-792-7277 Technical Support: www.microchip.com/support Web Address: www.microchip.com</p> <p>Atlanta Duluth, GA Tel: 678-957-9614 Fax: 678-957-1455</p> <p>Austin, TX Tel: 512-257-3370</p> <p>Boston Westborough, MA Tel: 774-760-0087 Fax: 774-760-0088</p> <p>Chicago Itasca, IL Tel: 630-285-0071 Fax: 630-285-0075</p> <p>Dallas Addison, TX Tel: 972-818-7423 Fax: 972-818-2924</p> <p>Detroit Novi, MI Tel: 248-848-4000</p> <p>Houston, TX Tel: 281-894-5983</p> <p>Indianapolis Noblesville, IN Tel: 317-773-8323 Fax: 317-773-5453 Tel: 317-536-2380</p> <p>Los Angeles Mission Viejo, CA Tel: 949-462-9523 Fax: 949-462-9608 Tel: 951-273-7800</p> <p>Raleigh, NC Tel: 919-844-7510</p> <p>New York, NY Tel: 631-435-6000</p> <p>San Jose, CA Tel: 408-735-9110 Tel: 408-436-4270</p> <p>Canada - Toronto Tel: 905-695-1980 Fax: 905-695-2078</p>	<p>Australia - Sydney Tel: 61-2-9868-6733</p> <p>China - Beijing Tel: 86-10-8569-7000</p> <p>China - Chengdu Tel: 86-28-8665-5511</p> <p>China - Chongqing Tel: 86-23-8980-9588</p> <p>China - Dongguan Tel: 86-769-8702-9880</p> <p>China - Guangzhou Tel: 86-20-8755-8029</p> <p>China - Hangzhou Tel: 86-571-8792-8115</p> <p>China - Hong Kong SAR Tel: 852-2943-5100</p> <p>China - Nanjing Tel: 86-25-8473-2460</p> <p>China - Qingdao Tel: 86-532-8502-7355</p> <p>China - Shanghai Tel: 86-21-3326-8000</p> <p>China - Shenyang Tel: 86-24-2334-2829</p> <p>China - Shenzhen Tel: 86-755-8864-2200</p> <p>China - Suzhou Tel: 86-186-6233-1526</p> <p>China - Wuhan Tel: 86-27-5980-5300</p> <p>China - Xian Tel: 86-29-8833-7252</p> <p>China - Xiamen Tel: 86-592-2388138</p> <p>China - Zhuhai Tel: 86-756-3210040</p>	<p>India - Bangalore Tel: 91-80-3090-4444</p> <p>India - New Delhi Tel: 91-11-4160-8631</p> <p>India - Pune Tel: 91-20-4121-0141</p> <p>Japan - Osaka Tel: 81-6-6152-7160</p> <p>Japan - Tokyo Tel: 81-3-6880-3770</p> <p>Korea - Daegu Tel: 82-53-744-4301</p> <p>Korea - Seoul Tel: 82-2-554-7200</p> <p>Malaysia - Kuala Lumpur Tel: 60-3-7651-7906</p> <p>Malaysia - Penang Tel: 60-4-227-8870</p> <p>Philippines - Manila Tel: 63-2-634-9065</p> <p>Singapore Tel: 65-6334-8870</p> <p>Taiwan - Hsin Chu Tel: 886-3-577-8366</p> <p>Taiwan - Kaohsiung Tel: 886-7-213-7830</p> <p>Taiwan - Taipei Tel: 886-2-2508-8600</p> <p>Thailand - Bangkok Tel: 66-2-694-1351</p> <p>Vietnam - Ho Chi Minh Tel: 84-28-5448-2100</p>	<p>Austria - Wels Tel: 43-7242-2244-39 Fax: 43-7242-2244-393</p> <p>Denmark - Copenhagen Tel: 45-4485-5910 Fax: 45-4485-2829</p> <p>Finland - Espoo Tel: 358-9-4520-820</p> <p>France - Paris Tel: 33-1-69-53-63-20 Fax: 33-1-69-30-90-79</p> <p>Germany - Garching Tel: 49-8931-9700</p> <p>Germany - Haan Tel: 49-2129-3766400</p> <p>Germany - Heilbronn Tel: 49-7131-72400</p> <p>Germany - Karlsruhe Tel: 49-721-625370</p> <p>Germany - Munich Tel: 49-89-627-144-0 Fax: 49-89-627-144-44</p> <p>Germany - Rosenheim Tel: 49-8031-354-560</p> <p>Israel - Ra'anana Tel: 972-9-744-7705</p> <p>Italy - Milan Tel: 39-0331-742611 Fax: 39-0331-466781</p> <p>Italy - Padova Tel: 39-049-7625286</p> <p>Netherlands - Drunen Tel: 31-416-690399 Fax: 31-416-690340</p> <p>Norway - Trondheim Tel: 47-72884388</p> <p>Poland - Warsaw Tel: 48-22-3325737</p> <p>Romania - Bucharest Tel: 40-21-407-87-50</p> <p>Spain - Madrid Tel: 34-91-708-08-90 Fax: 34-91-708-08-91</p> <p>Sweden - Gothenberg Tel: 46-31-704-60-40</p> <p>Sweden - Stockholm Tel: 46-8-5090-4654</p> <p>UK - Wokingham Tel: 44-118-921-5800 Fax: 44-118-921-5820</p>