

TITLE: pone_ecp5_022_best		values checked
Document Number:		REV:
Date: 30.05.2022 15:51:30	Sheet: 1/6	

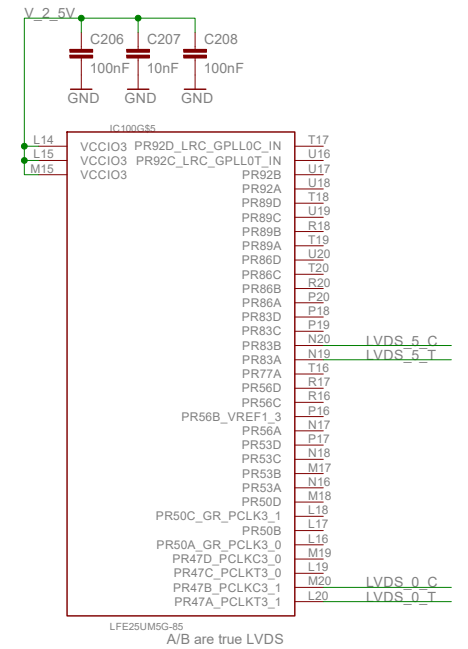
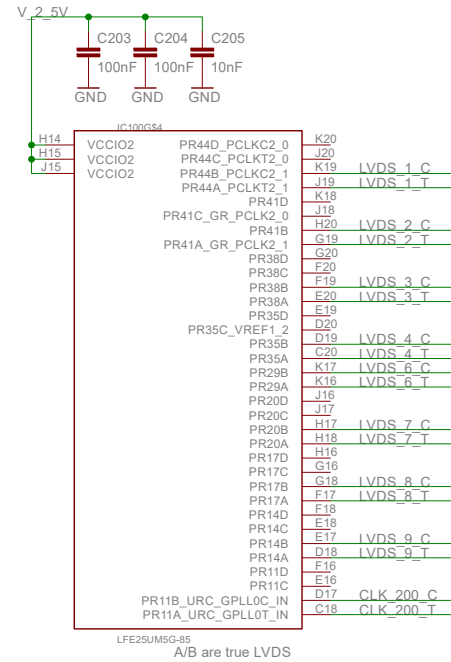
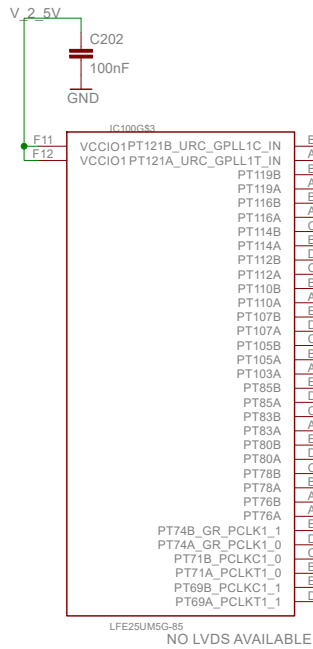
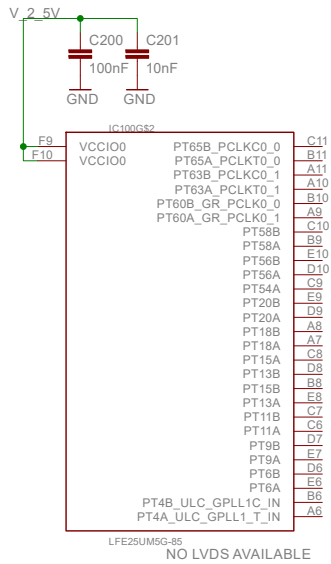

TITLE: pone_ecp5_022_best values checked

Document Number: REV:

Date: 30.05.2022 15:51:30 Sheet: 2/6

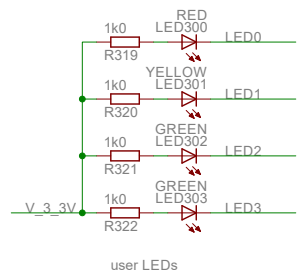
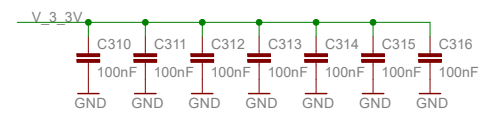
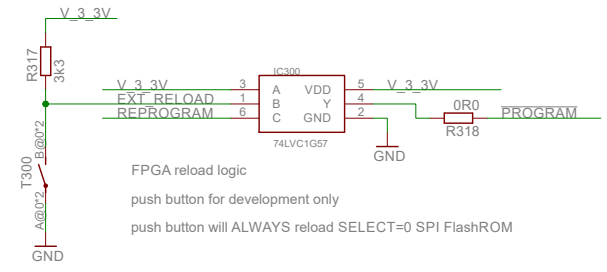
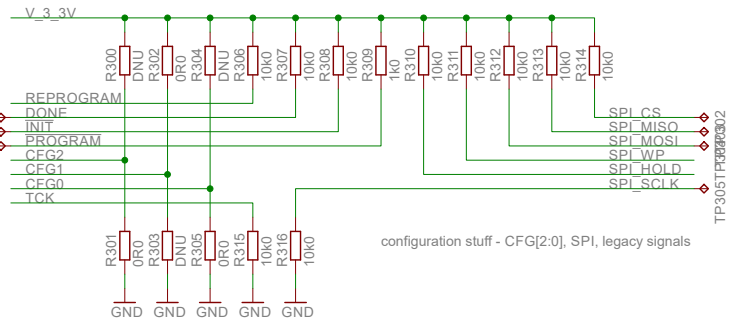
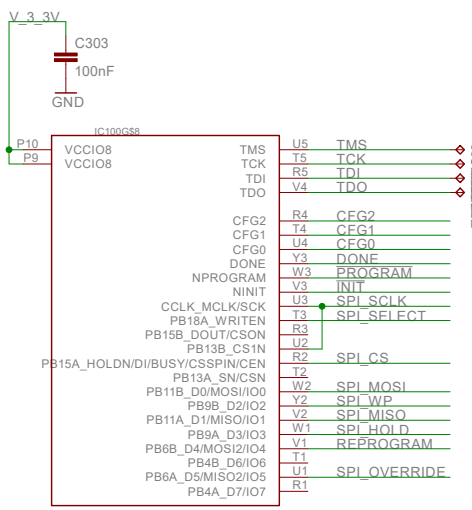
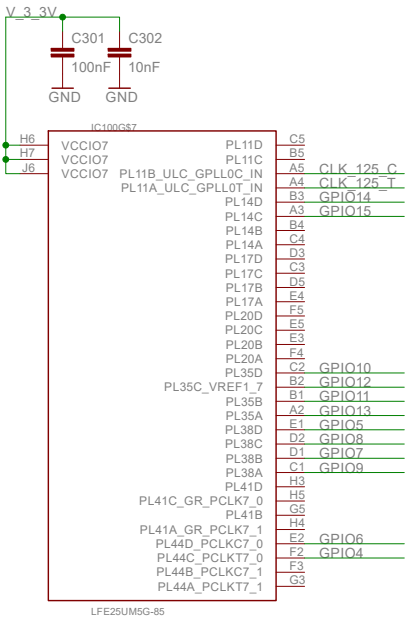
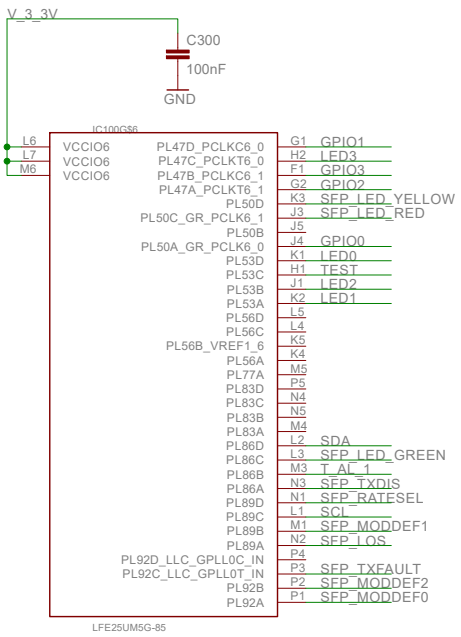

SPI boot selection
credits to Jan Michel (MDC MBO)
will select first SPI FlashROM after power up or longer power down.
SELECT=1 is held for ~5s
boot sequence will typically take 500ms

short power cycle (~1s) keeps SELECT=1
long power cycle (~10s) changes to SELECT=0
DO NOT GO BELOW ~5s to allow safe booting with SELECT=1

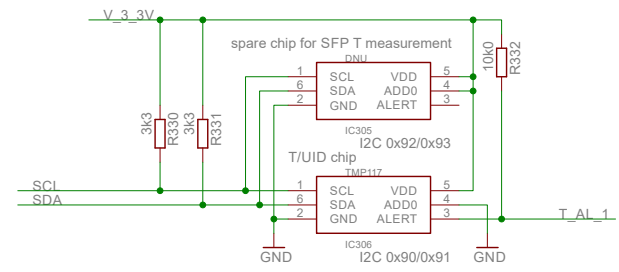
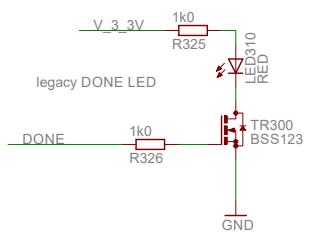
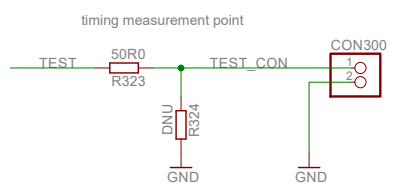
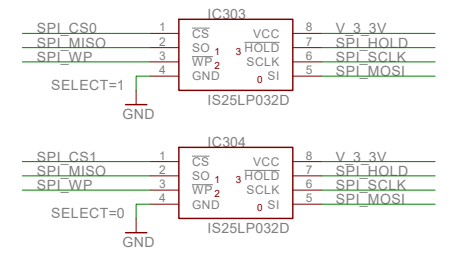
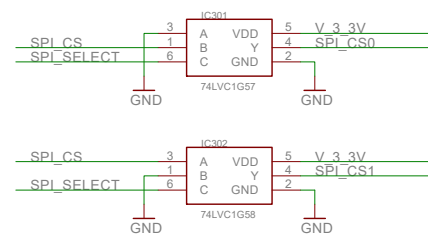
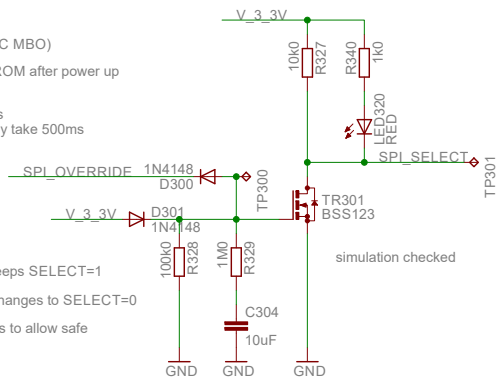

TITLE: pone_ecp5_022_best		values checked
Document Number:		REV:
Date: 30.05.2022 15:51:30		Sheet: 3/6

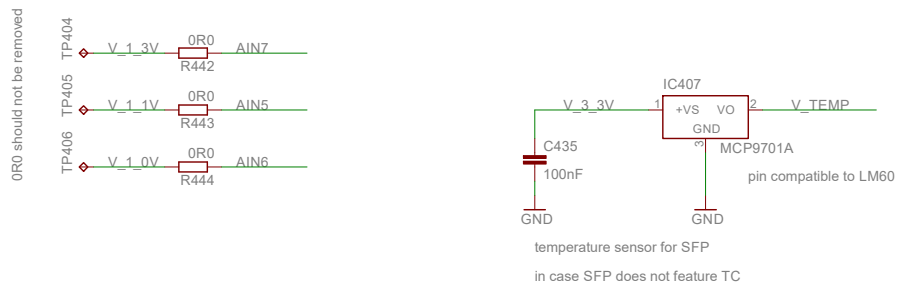
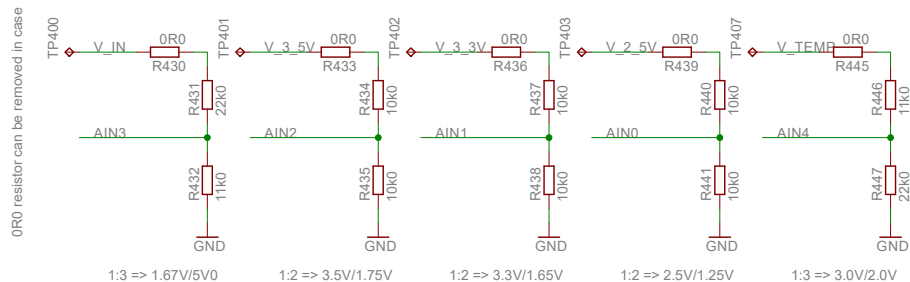
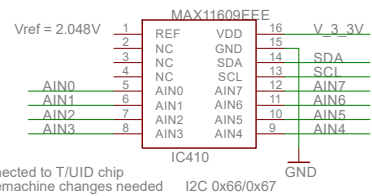
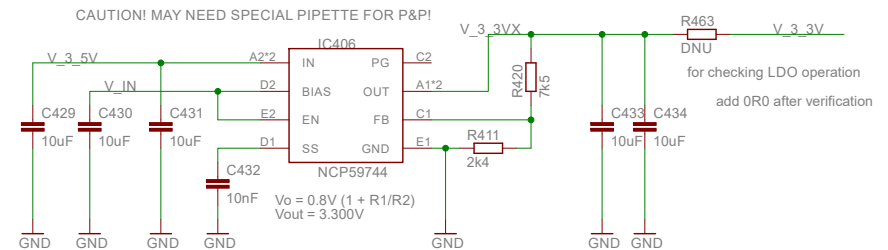
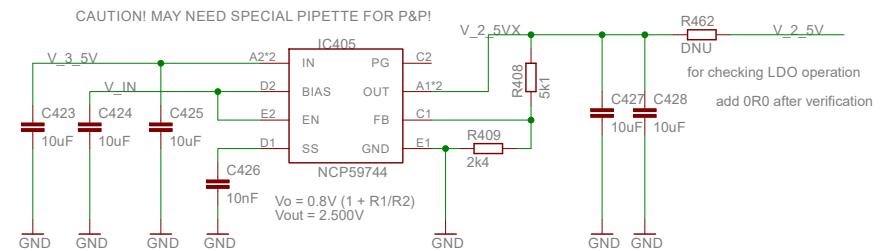
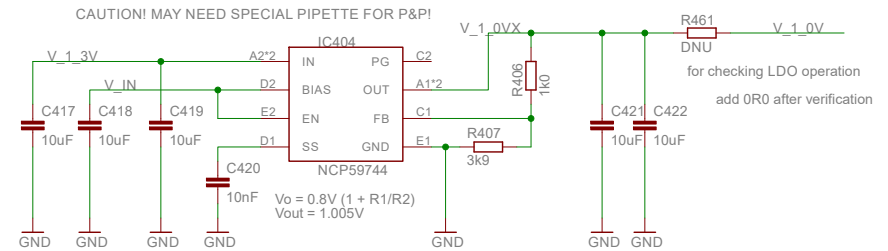
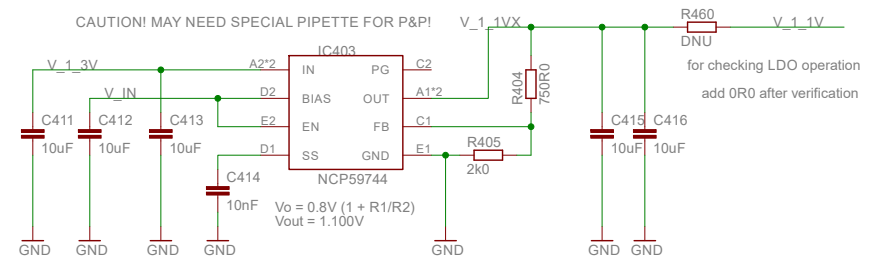
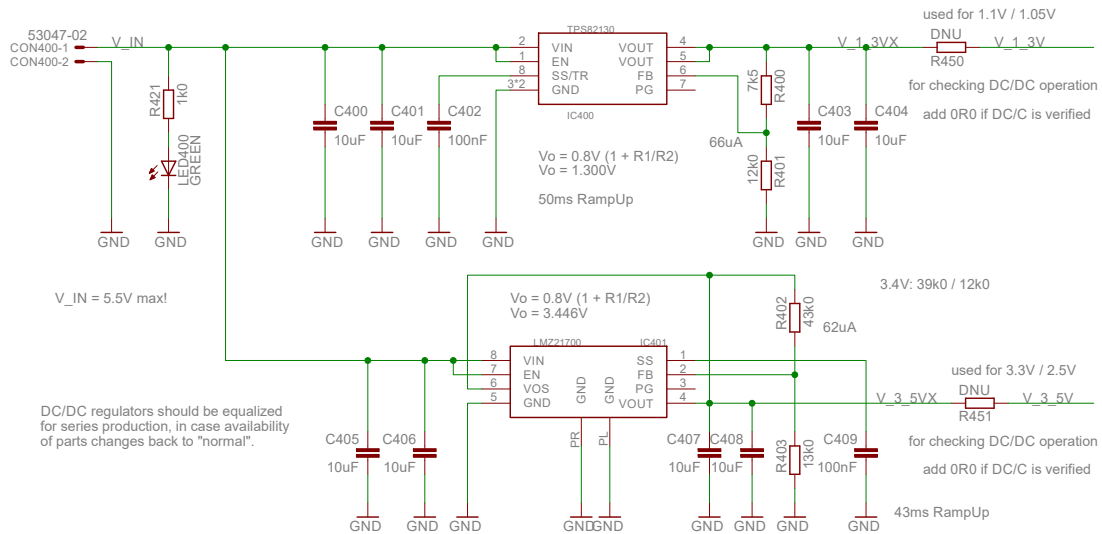

TITLE: pone_ecp5_022_best		values checked
Document Number:		REV:
Date: 30.05.2022 15:51:30	Sheet: 4/6	

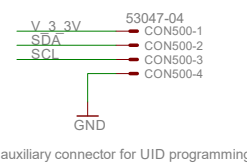
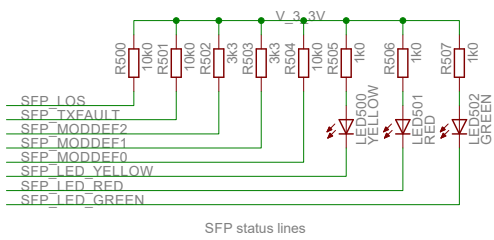
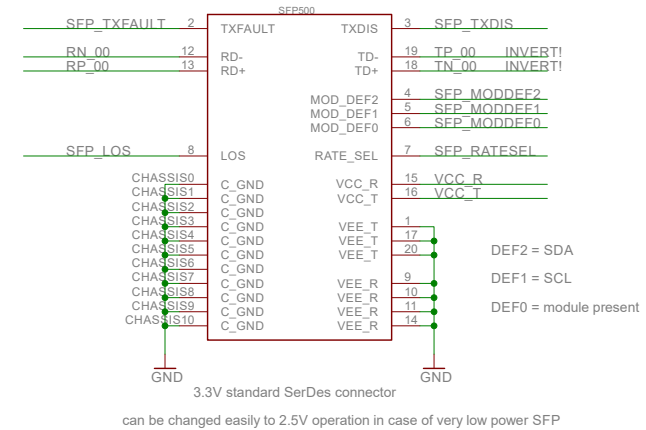
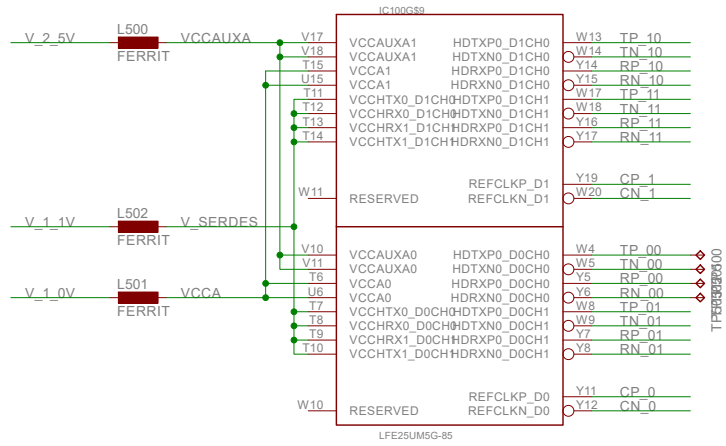
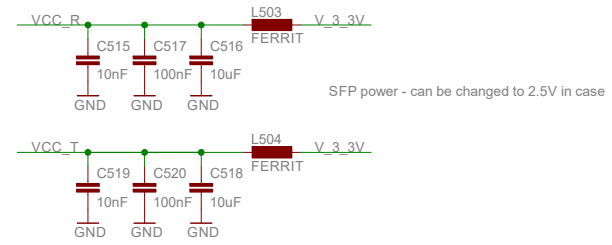
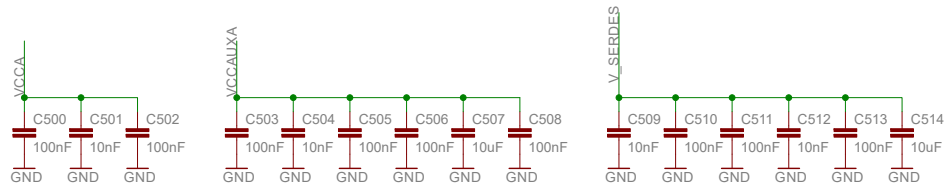

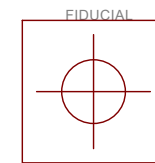
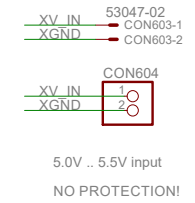
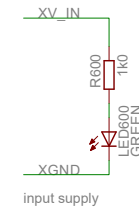
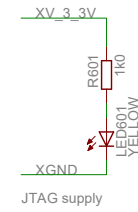
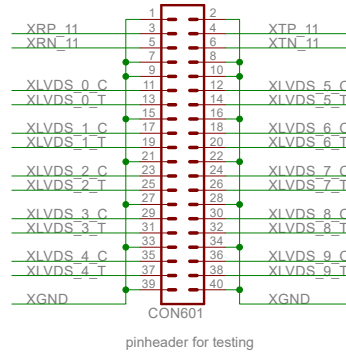
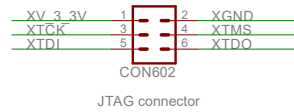
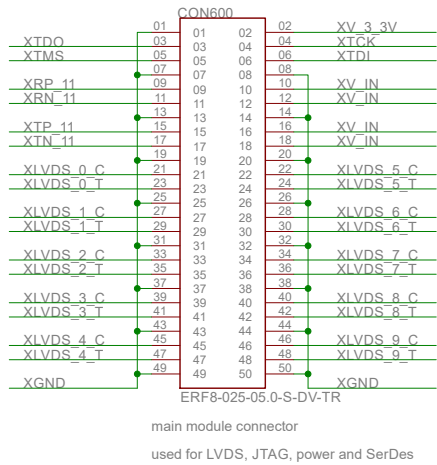

FID600

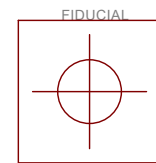

FID601

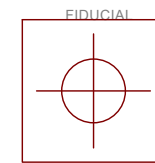

FID610

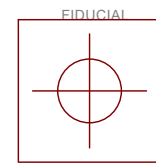

FID611

TITLE: pone_ecp5_022_best		values checked
Document Number:		REV:
Date: 30.05.2022 15:51:30	Sheet: 6/6	