

THE
ADVANCED ENERGY®
MDX 1.5K

User Manual

Serial Number: _____

ADVANCED ENERGY
INDUSTRIES, INC

1600 Prospect Parkway
Fort Collins, Colorado 80525

~~(303) 221-4670~~

Telex #45-0938

5700147-B

December 1990

(970) 221 0108

J. P. [unclear] 1.1 6247

To ensure years of dependable service, Advanced Energy® products are thoroughly tested and designed to be among the most reliable and highest quality systems available worldwide. All parts and labor carry our standard 1-year warranty.

For **Customer Service**, call:

AE, Colorado office	(303) 221-0108 (24-hour line) Fax: (303) 221-5583
AE, California office	(408) 263-8784 (8 a.m. to 5 p.m. Pacific Standard Time — California only) Fax: (408) 263-8992
AE, Northeast office	(508) 371-1381 Fax: (508) 369-1305
AE, Japanese office	81 (03) 3222-1311 Fax: 81 (03) 3222-1315
AE, German office	49 (0711) 777-87-18 Fax: 49 (0711) 777-87-00
all others	contact your local service center—see the list on the next page

©1989, Advanced Energy Industries, Inc

All rights reserved. Printed in the United States of America. This manual is supplied to enable the reader to safely install, operate, and service the equipment described herein. Making copies of any part of this manual for any purpose other than these is a violation of U.S. copyright law.

In the interest of providing even better equipment, Advanced Energy Industries, Inc., reserves the right to make product changes without notification or obligation.

For more information, write Advanced Energy Industries, Inc., 1600 Prospect Parkway, Fort Collins, CO 80525.

AE Service Centers

<u>Company Name</u>	<u>Phone/Fax Numbers</u>
Vacutec AB Sweden	46 (0) 40-437270 <i>Fax:</i> 46 (0) 40-435538
Gambetti Kenologia snc Italy	39 (02) 9055660 <i>Fax:</i> 39 (02) 9052778
Segen Technologies, Ltd. Israel	972 (03) 9363106 <i>Fax:</i> 972 (03) 9362030
Zeus Co., Ltd. Korea	82 (02) 577-3181 <i>Fax:</i> 82 (02) 576-3199
Schmidt Scientific Taiwan	886 (02) 5013468 <i>Fax:</i> 886 (02) 25029692

Returning Units for Repair

Before returning any product for repair and/or adjustment, call AE Customer Service and discuss the problem with them. Be prepared to give them the serial number of the unit and the reason for the proposed return. This consultation call will allow Customer Service to determine if the unit must actually be returned for the problem to be corrected. Such technical consultation is always available at no charge.

If you return a unit without first getting authorization from Customer Service, and that unit is found to be functional, you will have to pay a retest and calibration fee, and all shipping charges.

Upgrading Units

AE will upgrade older units for a fee (a percentage of the current list price, based on the age of the unit. Such an upgraded unit will carry a 6-month warranty (which will be added to any time remaining on the original warranty).

DESIGNED FOR MAGNETRONS

The new MDX series of magnetron drives are designed for hard use in a vacuum environment. Advanced circuit and semiconductor technology makes these amazing units more than 90% smaller and lighter than comparable equipment.

Performance is also remarkably improved through high-frequency switching techniques that reduce output energy storage. This decreases splatter and enables faster response to stabilize magnetron loads.

FULL POWER

The new MDX magnetron drives come equipped with standard features like a power regulator, interlock string, remote interface, full digital monitors, and an integrator.

The drive is fully protected from arcs and open/short circuits. Arc-Out™, a recent AE development, senses an abnormal load and quenches the arc before damage occurs.

FULL I/O

All displayed signals are available continuously at the rear I/O connector. In addition:

- analog control of ramp and output
- logic or contact control of ON/OFF
- fully buffered and ground referenced 0-5 V signals for voltage, current, and power
- logic outputs for interlock, output, and setpoint status information.

SERVICEABILITY -- MODULAR

Advanced Energy Industries, Inc., standard modules are used throughout the MDX, enabling replacements to be made in minutes without special tools, soldering, or adjustments.

CONFIDENCE

The MDX family is designed to be among the most reliable and quality-oriented systems available. All parts and labor carry our standard 1-year warranty, and for a small premium we will extend the warranty to a full 5 years.

CONTENTS

	<u>Page</u>
Warning.....	4
Safety.....	5
General Description.....	5
Specifications.....	6
Unpacking.....	6
Power Connections.....	6
Interface, User Connector.....	7
Interface, Front Panel.....	15
Output Connector.....	19
Operation.....	19
Principles of Operation.....	20
Warranty.....	21

******* WARNING *******

PROPER USE AND SAFE OPERATING PROCEDURES OF THE EQUIPMENT ARE THE RESPONSIBILITY OF THE USER OF THIS SYSTEM.

Advanced Energy Industries, Inc., provides information on its products and associated hazards, but it assumes no responsibility for the after-sale operation and safety practices. Take appropriate action to protect personnel and property from hardware failure.

ALL PERSONNEL WHO WORK WITH OR ARE EXPOSED TO THIS EQUIPMENT MUST TAKE PRECAUTIONS TO PROTECT THEMSELVES AGAINST POSSIBLE SERIOUS AND/OR FATAL BODILY INJURY. DO NOT BE CARELESS AROUND THIS EQUIPMENT.

1.0 SAFETY

The high-voltage nature of the output of these power supplies dictates the use of caution when near the output power connection.

Precautions:

1. Make certain that the chassis is properly grounded -- **THE GROUND CONNECTION PROVIDED SHOULD NOT BE DEFEATED!**
2. Do not remove the protective covers from the support during operation.

2.0 GENERAL DESCRIPTION

The MDX series of magnetron drives are designed as power sources for dc magnetron applications.

The unit will reliably deliver full power to a magnetron cathode at 750 V.

This power is controlled within any of three regulation modes: power, current, or voltage. The control can be made from the front panel or a user port.

Full instrumentation is included, as is a programmable ramp, a full interlock string, and front panel setpoint lock.

A high-frequency conversion technique coupled with a proprietary Arc-Out™ circuit makes possible extremely low stored energy, reducing energy discharged into an arc by several orders of magnitude. This greatly decreases splatter and thermal shock on sensitive targets.

3.0 SPECIFICATIONS

Input Voltage	208 V ac +/- 10%, 50/60 Hz
Input Current	8 A nominal at 1.5 kW (full power) 0.92 power factor 15 A circuit breaker
Output Power	0-1500 W
Output Voltage	0-750 V, 1200 V open circuit voltage
Output Current	0-2 A
Output Ripple	5% rms max., ripple frequency = 50 kHz
Cooling	0-45 degrees C ambient. Three inches of clearance to the rear and one side of unit is required.
Humidity	0-92% noncondensing

4.0 UNPACKING

DO NOT APPLY POWER TO THE UNIT BEFORE FOLLOWING THIS PROCEDURE:

Unpack and inspect your power supply carefully. Check for any sticking switches on the front panel and any obvious physical damage.

Remove the top cover (6 phillips screws). Inspect the plexiglass for signs of physical damage. If no damage is observed, proceed to the next section.

4.1 POWER CONNECTIONS

The standard power is 208 V +/- 10% at 50/60 Hz. A three-prong, grounded U.S. standard connector is provided with the unit. DO NOT OPERATE ON AN UNGROUNDED OUTLET. DO NOT CUT OFF GROUND TAB.

WARNING

MAKE CERTAIN USER MAIN CIRCUIT BREAKER IS OFF DURING HOOKUP.

4.2 INTERFACE, USER CONNECTOR

Connector -- Subminiature "D" (25 pin)

PIN #	NAME	DESCRIPTION	REF.
1	A.IOOUT	Analog signal representing output current	4.2.1
2	A.POUT	Analog signal representing output power	4.2.2
3	A.VOUT	Analog signal representing output voltage	4.2.3
4	D.XWATER	User water interlock	4.2.4
5	D.XVAC	User vacuum interlock	4.2.4
6	D.XAUX	User auxiliary interlock	4.2.4
7	D.XOFF	Remote system off command	4.2.5
8	D.XON	Remote system on command	4.2.6
9	INTLKCOM	Interlock common	4.2.7
10	A.XREF	External reference voltage (5 V)	4.2.8
11	A.RAMPOUT	Analog signal representing ramp program	4.2.9
12	A.LEVELOUT	Analog signal representing level program	4.2.10
13	D.SETPOINT	Digital indication representing output at setpoint	4.2.11
14	A.VAUX	External voltage (15 V)	4.2.12
15	unassigned		
16	unassigned		
17	unassigned		
18	unassigned		
19	unassigned		
20	M.COM	Meter common	4.2.13
21	OUTCOM	Indicator common	4.2.14
22	D.OUTPUT	Digital indication representing output present	4.2.15

PIN #	NAME	DESCRIPTION	REF.
23	A.XLEVEL	Remote system level adjust	4.2.16
24	A.XRAMP	Remote system ramp adjust	4.2.17
25	INCOM	External program common	4.2.18

Note: All levels that are referred to as high are 15 V logic unless otherwise stated.

4.2.1 A.IOUT

The A.IOUT connection provides a fully buffered 0-5 V output signal representing output current. 5 V equals 2 A for an MDX 1.5K (see Diagram 5). A.IOUT is referenced to M.COM. Source impedance is 100 ohms.

4.2.2 A.POUT

The A.POUT connection provides a fully buffered 0-5 V output signal representing output power. 5 V equals 1500 W for an MDX 1.5K (see Diagram 5). A.POUT is referenced to M.COM. Source impedance is 100 ohms.

4.2.3 A.VOUT

The A.VOUT connection provides a fully buffered 0-5 V output signal representing output voltage. 5 V equals 750 V dc (see Diagram 5). A.VOUT is referenced to M.COM. Source impedance is 100 ohms.

4.2.4 D.XAUX, D.XVAC, D.XWATER

These allow the user to gain access to the interlock string. With the string satisfied, the main contactor will not close, or if the contact is closed, breaking the string will cause the main contactor to open. If the interlock string is broken, the appropriate interlock status indicator will flash. To turn on the magnetron drive again, the failed interlock must be corrected. If the interlock conditions have been met, the interlock status indicators will be lit but will not flash. After a failed interlock has been corrected, D.XON or OUTPUT ON will turn on the magnetron drive. Connect the appropriate interlock through a closed switch on INTLKCOM to indicate a good interlock (see Diagram 2).

4.2.5 D.XOFF

The D.XOFF command duplicates the OUTPUT OFF of the front panel. This function overrides all other commands and forces the magnetron drive to turn off by opening the main contactor.

4.2.6 D.XON

The D.XON command allows remote turn on of the magnetron drive. To use this command, the REMOTE ON must be selected on the rear panel (see Fig. 1). This transfers the OUTPUT ON command to D.XON. A momentary contact closure of D.XON to INTLKCOM will cause the magnetron drive to turn on if D.XOFF is connected through a contact closure to INTLKCOM (see Diagram 3). A two-wire command is possible with D.XON and D.XOFF connected together. If this is done, both must be connected to INTLKCOM continuously to turn on the magnetron drive (see Diagram 4).

4.2.7 INTLKCOM

All interlock connections are referred to INTLKCOM, a dedicated ground that returns to the internal system ground, the chassis ground, and finally safety ground.

4.2.8 A.XREF

The A.XREF connection provides the user with an accurate 5 V reference (5 V +/- 10 mV). Reference A.XREF to INCOM. Note: Do not load the A.XREF to more than 5 mA. Source impedance is 100 ohms.

4.2.9 A. RAMP

The A.RAMP connection provides a fully buffered 0-5 V output signal representing the amount of time for the output ramp. 5 V equals 10 sec. or min., whichever is selected (see Fig. 1). Source impedance is 100 ohms.

4.2.10 A.LEVEL

The A.LEVEL connection provides a fully buffered 0-5 V output signal representing the presently programmed setpoint of the magnetron drive. 5 V equals maximum setpoint. Reference A.LEVEL to M.COM. Source impedance is 100 ohms.

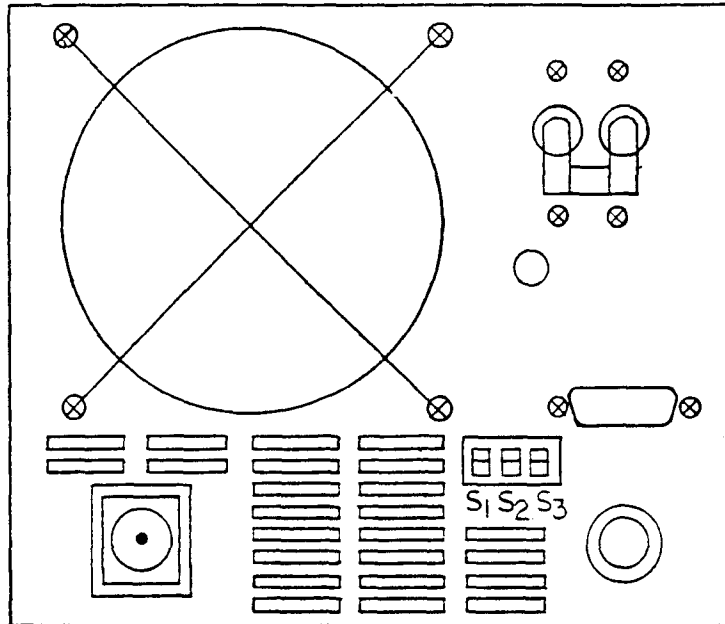

Switch S1 -- RAMP

This switch changes the ramp from 1-10 sec. (switch in upper position) to 1-10 min. (switch in lower position).

Switch S2 -- REMOTE PROGRAM

This switch changes the program control from the front panel control (switch in the upper position) to user connector control (switch in the lower position). The user connector is used for both level programming (A.XLEVEL) and for ramp programming (A.XRAMP).

Switch S3 -- REMOTE ON

This switch changes the OUTPUT ON control from the front panel (switch in the upper position) to the user connector (switch in the lower position).

Figure 1. MDX 1.5K rear chassis switch location.

4.2.11 D.SETPOINT

D.SETPOINT is an output signal that duplicates the SETPOINT light indication on the front panel. D.SETPOINT goes low when the output setpoint has been reached. D.SETPOINT should be referenced to OUTCOM. D.SETPOINT will flash at a rate of approximately 3.5 Hz. When the output is not at setpoint, it will flash at approximately 15 Hz when the output is ramping.

4.2.12 A.VAUX

The A.VAUX connection is a user-available 15 V referenced to OUTCOM. This output is internally limited at 100 mA.

4.2.13 M.COM

All meter connections are referenced to M.COM, a dedicated ground that returns to internal system ground, then chassis ground, and finally safety ground.

4.2.14 OUTCOM

Ground return used as a reference for MDX that parallels front panel status indicators. A dedicated ground that returns to the internal system ground, then chassis ground, and finally safety ground.

4.2.15 D.OUTPUT

D.OUTPUT is an output signal that duplicates the OUTPUT light indication on the front panel. The OUTPUT light on the front panel will illuminate when the output is enabled. D.OUTPUT goes high when the output is enabled. Reference D.OUTPUT to OUTCOM. Source impedance is 100 ohms.

4.2.16 A.XLEVEL

The A.XLEVEL connection allows the user to program output level from an external source (see Diagram 6). The signal should be 0-5 V, with 5 V being maximum output. To enable this function, REMOTE PROGRAM must be selected (see Fig. 1). Reference A.XLEVEL to INCOM. Source impedance is 100 ohms.

4.2.17 A.XRAMP

The A.XRAMP connection allows the user to program ramp time from an external source (see Diagram 6). The signal should be 0-5 V, with 5 V being maximum ramp time (10 min. or sec.). To enable this function, REMOTE PROGRAM must be selected on the rear panel (see Fig. 1). Reference A.XRAMP to INCOM. Source impedance is 100 ohms.

4.2.18 INCOM

All analog input control connections are referenced to INCOM, a dedicated ground that returns to the internal system ground, then chassis ground, and finally safety ground.

USER PLUG

CHEATS ALL INTERLOCKS

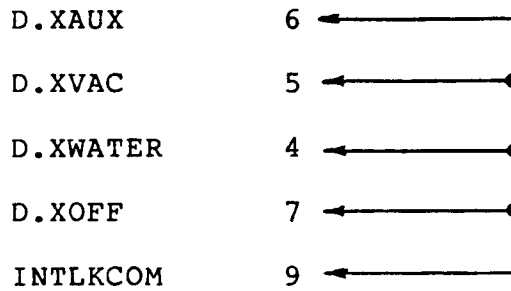

DIAGRAM 1. CHEATER PLUG

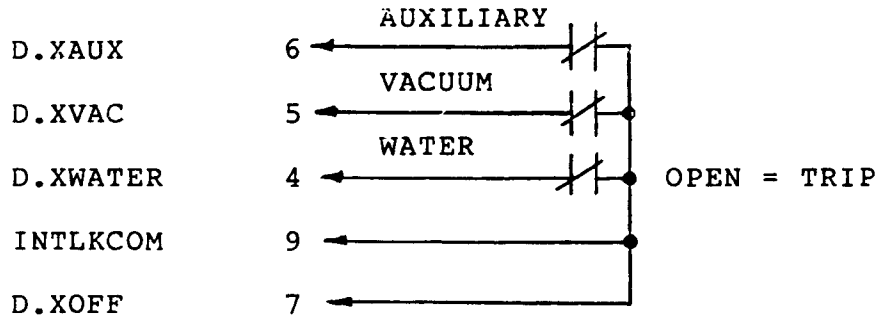

DIAGRAM 2. NORMAL INTERLOCK CONNECTION

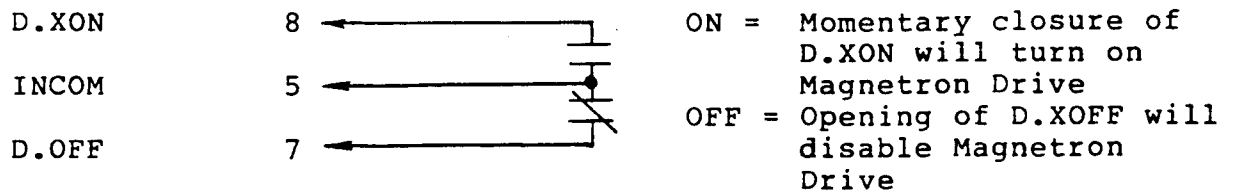

DIAGRAM 3. THREE-WIRE CONTROL CONNECTION

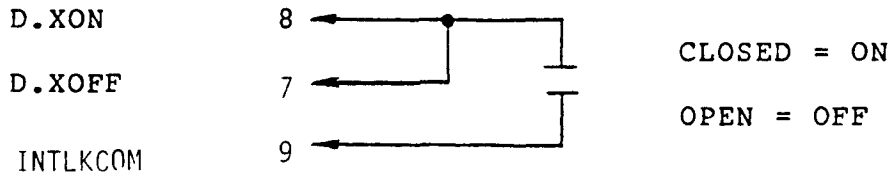

DIAGRAM 4. TWO-WIRE CONTROL CONNECTION

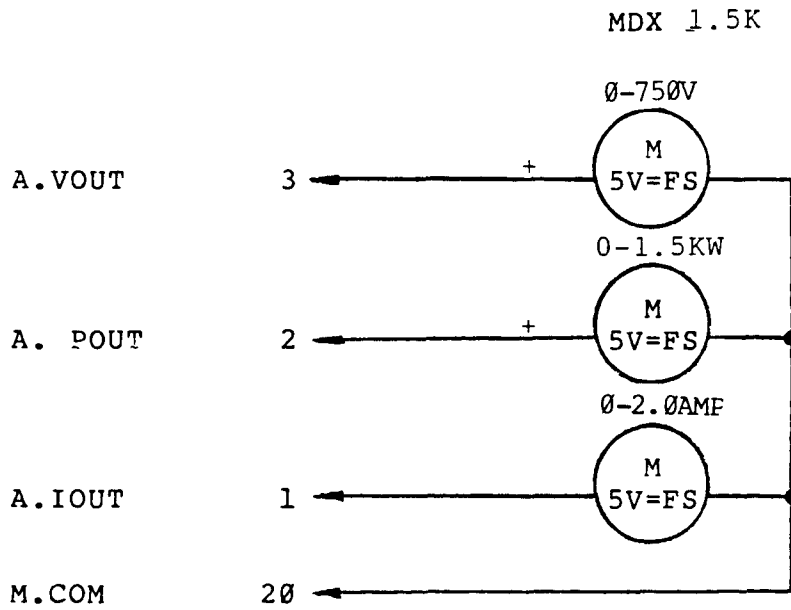

DIAGRAM 5. EXTERNAL METERING

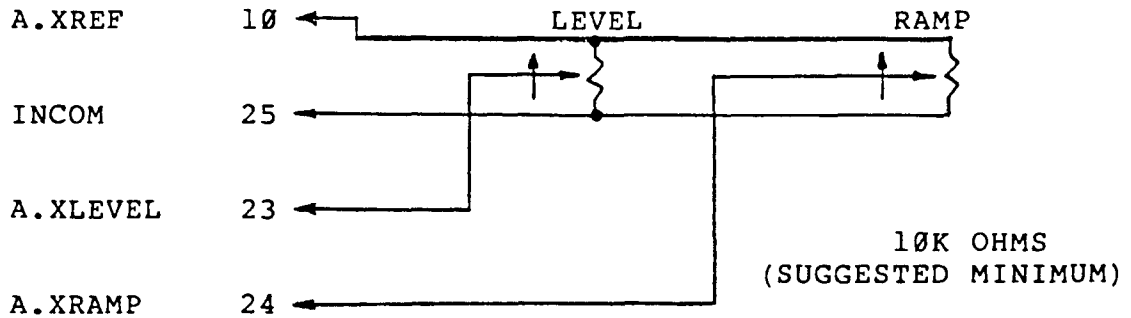

DIAGRAM 6. EXTERNAL PROGRAMS

4.3 INTERFACE, FRONT PANEL

4.3.1 POWER

The power button turns on the internal power of the power supply.

4.3.2 OUTPUT OFF

The OUTPUT OFF button will turn off the magnetron drive.

4.3.3 OUTPUT ON

The OUTPUT ON button turns on the magnetron drive if the front panel mode is selected, a regulation mode has been selected, and all interlocks are satisfied. If a setpoint value has previously been programmed, the MDX will go to that value when turned on.

4.3.4 REGULATION; POWER, CURRENT, VOLTAGE

The MDX magnetron drive allows three modes of regulation: power, current, or voltage. The current mode is selected by pressing CURRENT, the power mode by pressing POWER, and the voltage mode by pressing both POWER and CURRENT simultaneously. The user can change modes only when the output has been turned off.

4.3.5 LEFT DISPLAY

The left display allows continuous monitoring of the regulation mode. When the regulation mode is changed (see paragraph 4.3.4) the parameter that is monitored changes to the new mode.

4.3.6 STATUS

4.3.6.1 ARC

The ARC LED flashes when an arc is sensed or if the Arc-Out™ circuit is activated.

4.3.6.2 SETPOINT

The SETPOINT LED turns on when the output reaches the preselected setpoint. It will flash if current, voltage, or power exceeds the maximum limit or if the output cannot reach the programmed level.

4.3.6.3 RAMP

The RAMP LED will rapidly flash when the output is ramping toward the preselected setpoint. If the output is out of regulation, the LED will flash at a slower rate. Once the final setpoint is reached, the LED will turn off.

4.3.6.4 PLASMA

The PLASMA LED turns on when a minimum current threshold is being delivered to the load.

4.3.6.5 OUTPUT

The OUTPUT LED turns on when the magnetron drive has been enabled and the main contactor closes.

4.3.6.6 TEMP

Senses internal overtemperature.

4.3.6.7 INTERLOCK

This LED is a user interlock indicator. The LED is on when the interlock is satisfied. A failed interlock will cause its LED to extinguish. When an interlock fails, the magnetron drive is turned off and cannot be restarted until the interlock failure is corrected and the LED is on again.

4.3.7 SETPOINT

The SETPOINT button allows the user to preprogram the output level. Press this button (the regulation mode LED and the SETPOINT LED will turn on) while watching the right display to program the ramp time.

4.3.8 LEVEL

The LEVEL knob is used to program the output level. Drive setpoints can be programmed in either the ON or OFF mode. If the level is changed during a ramp, the output changes for the ramp to finish at its preprogrammed time. Once the output is at the preprogrammed level, the LEVEL knob has full control of the output level.

4.3.9 RAMP

The RAMP knob allows the user to preprogram the amount of ramp time (time from 0 output to the preprogrammed level). This can be programmed for either 1-10 sec. or 1-10 min. (see Fig. 1).

4.3.10 RIGHT DISPLAY

The right display allows continuous monitoring of the following parameters in conjunction with the ACTUAL and SETPOINT switches.

4.3.10.1 KW

When the KW LED is on, the display is either monitoring output kilowatts if the ACTUAL LED is on or monitoring the power setpoint if the SETPOINT LED is on and the supply is in the power regulation mode. Press the SETPOINT or the ACTUAL button.

4.3.10.2 VOLTS

When the VOLTS LED is on, the right display is either monitoring output voltage if the ACTUAL LED is on or monitoring the voltage regulation setpoint if the SETPOINT LED is on and the supply is in the voltage regulation mode. Press the SETPOINT or ACTUAL button.

4.3.10.3 AMPS

When the AMPS LED is on, the right display is either monitoring output current if the ACTUAL LED is on or monitoring the current regulation setpoint if the SETPOINT LED is on and the supply is in the current regulation mode. Press the SETPOINT or ACTUAL button.

4.3.10.4 MINUTES or SECONDS

When the MINUTES or SECONDS and SETPOINT LEDs are on,, the right display shows the ramp setpoint.

4.3.11 SETPOINT

The SETPOINT button allows the user to check programmed setpoints. If the right display indicates MINUTES or SECONDS, pressing the SETPOINT button allows the user to see the programmed regulation mode setpoint. If the right display indicates KW, VOLT, or AMP, pressing the SETPOINT button allows the user to check the programmed regulation mode setpoint.

4.3.12 ACTUAL

The ACTUAL button allows the user to select the desired mode of monitoring on the right display.

4.4 OUTPUT CONNECTOR

Connector Amphenol 83-822

Use RG-8U cable for the output connection. The correct connection has been supplied.

Note: The shield is connected to the chassis ground and will be positive or negative referenced to the center connector as ordered.

5.0 OPERATION

Connect the output connector.

Turn on the breaker on the rear panel of the magnetron drive.

Press the power switch in until it latches.

All displays will read zero. The OUTPUT OFF LED will be lit. Other lights that will be on include both DISPLAYs, a regulation mode (if it has been selected), and the ACTUAL LED.

Select a regulation mode (current, power, or voltage) by pressing the appropriate button. The corresponding LED(s) will light.

Press SETPOINT twice and adjust the ramp rate. Watch the right display for the desired value (refer to paragraph 4.3.9).

Press SETPOINT and adjust the output level. Watch the right display for the desired value (refer to paragraph 4.3.8).

Press ON to enable the output. The contactor will close, the ARC LED will momentarily light, and the OUTPUT, RAMP, and PLASMA LEDs will come on (refer to paragraph 4.3.3).

The output will ramp to the selected output level, at which time the RAMP LED will go out and the SETPOINT LED will come on.

6.0 PRINCIPLES OF OPERATION

6.1 BLOCK DIAGRAM

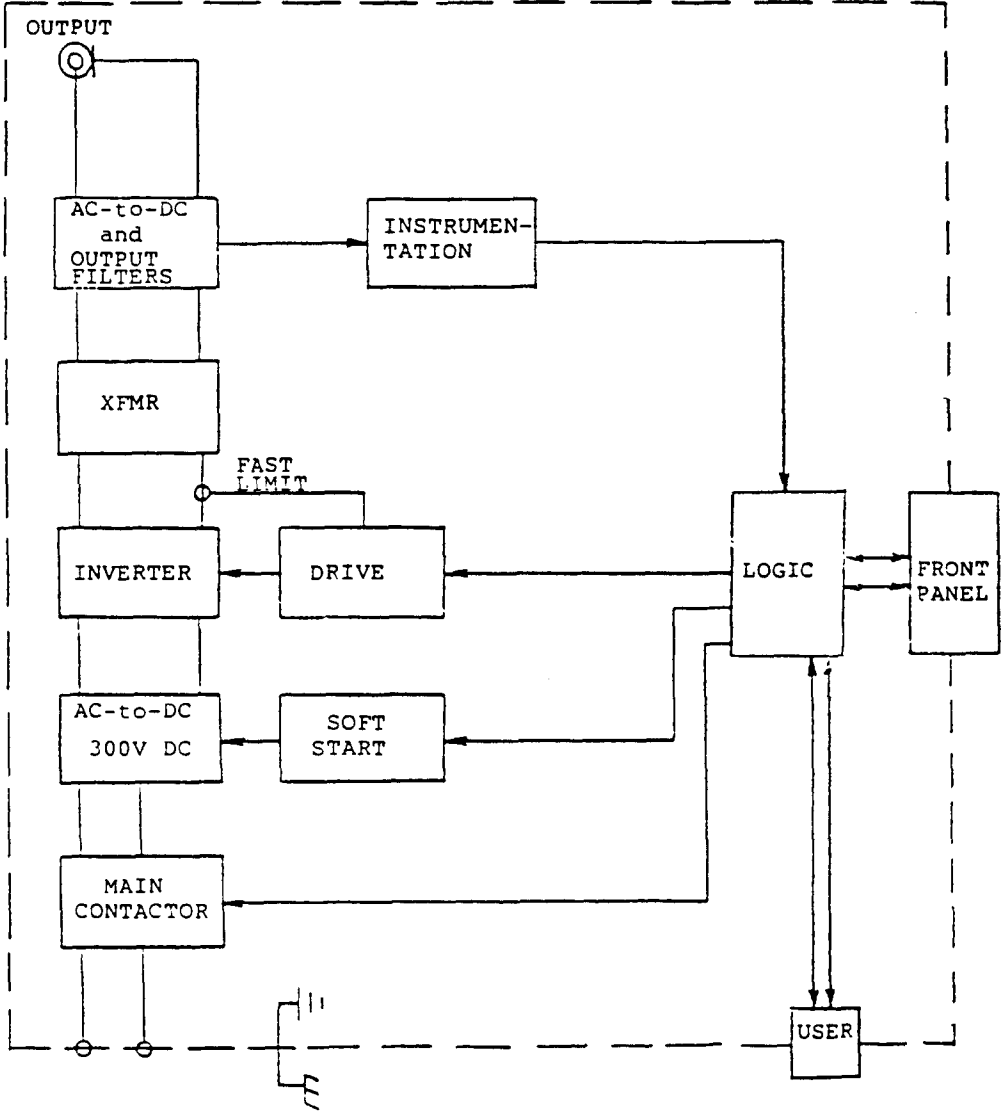

Warranty Claims

Advanced Energy® products are warranted to be free from failures due to defects in material and workmanship for 12 months after they are shipped from the factory (please see warranty statement, below, for details).

In order to claim shipping or handling damage, you must inspect the delivered goods and report such damage to AE within 30 days of your receipt of the goods. Please note that failing to report any damage within this period is the same as acknowledging that the goods were received undamaged.

For a warranty claim to be valid, it must:

- be made within the applicable warranty period
- include the product serial number and a full description of the circumstances giving rise to the claim
- have been assigned a return authorization number (see below) by AE Customer Service

All warranty work will be performed at an authorized AE service center (see list of contacts at the front of the manual). You are responsible for obtaining authorization (see details below) to return any defective units, prepaying the freight costs, and ensuring that the units are returned to an authorized AE service center. AE will return the repaired unit (freight prepaid) to you by second-day air shipment (or ground carrier for local returns); repair parts and labor will be provided free of charge. Whoever ships the unit (either you or AE) is responsible for properly packaging and adequately insuring the unit.

Authorized Returns

Before returning any product for repair and/or adjustment, call AE Customer Service and discuss the problem with them. Be prepared to give them the serial number of the unit and the reason for the proposed return. This consultation call will allow Customer Service to determine if the unit must actually be returned for the problem to be corrected. Such technical consultation is always available at no charge.

Units that are returned without authorization from AE Customer Service and that are found to be functional will not be covered under the warranty (see warranty statement, below). That is, you will have to pay a retest and calibration fee, and all shipping charges.

Upgrading Units

AE's products are continually changing as ways to improve them are discovered. AE is happy to upgrade older units so that they reflect recent improvements. The fee for upgrading a unit will be a percentage of the current list price, based on the age of the unit. Such an upgraded unit will carry a 6-month warranty (which will be added to any time remaining on the original warranty). Contact Customer Service for specifics on getting an older unit upgraded to the current revision level.

Warranty

The seller makes no express or implied warranty that the goods are merchantable or fit for any particular purpose except as specifically stated in printed AE specifications. The sole responsibility of the Seller shall be that it will manufacture the goods in accordance with its published specifications and that the goods will be free from defects in material and workmanship. The seller's liability for breach of an expressed warranty shall exist only if the goods are installed, started in operation, and tested in conformity with the seller's published instructions. The seller expressly excludes any warranty whatsoever concerning goods that have been subject to misuse, negligence, or accident, or that have been altered or repaired by anyone other than the seller or the seller's duly authorized agent. This warranty is expressly made in lieu of any and all other warranties, express or implied, unless otherwise agreed to in writing. The warranty period is 12 months after the date the goods are shipped from AE. In all cases, the seller has sole responsibility for determining the cause and nature of the failure, and the seller's determination with regard thereto shall be final.