

# SEREN

INDUSTRIAL POWER SYSTEMS INC.

---

## **MM-Series MANUAL IMPEDANCE MATCHING NETWORK OPERATOR'S MANUAL**

Revision 1.00

Document Number 6200120000

SEREN Industrial Power Systems, Inc.  
1717 Gallagher Drive  
Vineland, New Jersey, 08360  
U.S.A.

Telephone: 856-205-1131  
Fax: 856-205-1141  
E-mail: [info@serenips.com](mailto:info@serenips.com)

Copyright ©2004, Seren IPS Inc.

## **Introduction**

Thank you for acquiring your new SEREN IPS MM-Series Manual Impedance Matching Network. All MM-Series Matching Networks have been designed to provide the best value, ease of operation, and reliability for plasma processing, RF processing, and coating systems. This manual covers specifications, installation, and operation of the MM-Series Manual Matching Network.

## **Information**

For technical questions, application assistance, or additional information, contact our customer service department or nearest customer service representative.

## **Service**

Customer Service Representatives are available to answer your technical questions. Should your Seren IPS product require service, contact the nearest Seren IPS, Inc. service representative for a Return Materials Authorization Number. Any returned equipment should be sent freight prepaid.

Please note: Equipment returned to us without prior authorization or without a Return Materials Authorization (RMA) number visible on the outside of the package will be refused.

## **How to Contact Us**

Our address, telephone, and fax numbers are listed below. Office hours are Monday through Friday, 8:00am to 5:00pm, United States Eastern Time

SEREN Industrial Power Systems, Inc.  
1717 Gallagher Drive  
Vineland, New Jersey, 08360 U.S.A.

Telephone: 856-205-1131  
Fax: 856-205-1141

## **Proprietary Information Notice**

This document contains information proprietary to SEREN IPS Inc. This document shall not be reproduced or its contents disclosed without the written permission of SEREN IPS Inc. This notice shall appear in all copies.

**TABLE OF CONTENTS**

Safety Notes .....	3
MM-Series Manual Matching Network Features .....	5
Physical Dimensions .....	6
Controls and Connections .....	8
Unpacking .....	11
Installation .....	11
Operation .....	13
Matching Network "Cold" Setup .....	13
Matching Network First-Use Tuning .....	13
Matching Network Operation After First-Use Tuning .....	14
Technical Data .....	15
Ratings and Specifications .....	15
Tuning Range, MM300 Manual Matching Network .....	16
Tuning Range, MM3X Manual Matching Network .....	17
Tuning Range, MM6 Manual Matching Network .....	18
Theory of Operation .....	19
Chassis Schematics .....	20
Typical System Configuration .....	22
Maintenance .....	23
Problem Solving .....	24
Range Configuration .....	26
Seren 1 Year Limited Warranty .....	27
Obtaining Service For The MM-Series Manual Matching Network .....	27
Glossary Of Terms .....	28
Revision History .....	29

## Safety Notes

Your MM-Series Manual matching Network has been designed and tested to meet strict safety requirements. These include independent lab examination and approval, and compliance to established standards. Please read the following instructions carefully before operating the Matching Network and refer to them as needed to ensure the continued safe operation of your MM-Series Matching Network.

**Follow** all warnings and instructions marked on or supplied with the product.

### Symbology:

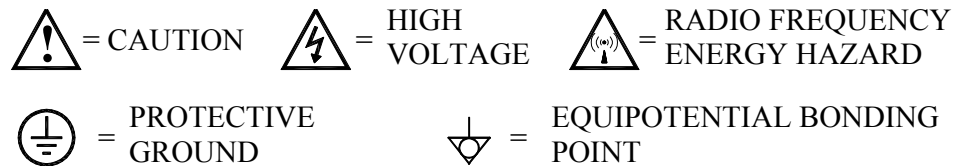

**Unplug** or disconnect this equipment from the Radio Frequency (RF) power source before removal of any covers.

**Do not** use this equipment near wet locations, or outdoors.

**Do not** place this equipment on an unstable cart, stand, or table. The MM-Series Matching Network may fall, causing personal injury or damage to the Matching Network. Improper grounding of the Matching Network to the system can result in electrical shock.

**To avoid electric shock**, this unit must be connected in compliance with the National Electrical Code ANSI C1 and/or any other codes applicable to the user. Improper installation may result in a shock or fire hazard.

**It is the responsibility** of the installer to provide a proper protective ground from the Matching Network to the system. The system should be grounded in accordance with local and national electrical codes, and any other codes applicable to the user.

**Do not** allow anything to rest on the interconnecting cables. Do not locate the MM-Series Matching Network where persons will step on the interconnecting cables.

**Never** spill liquid of any kind on or into the Matching Network.

**Never** remove covers or guards that require a tool for removal. This should be performed by a qualified service engineer at the initial matching network set-up configuration for your specific plasma impedance. There are no operator serviceable areas within these covers. Refer servicing to qualified service personnel.

**This product** is to be operated only when all covers are installed, appropriate RF Connections have been made, and all RF Cables are in place and tightened. **DO NOT** operate this unit without connecting the output with the appropriate output cable or strap connected to the plasma reactor.

**HAZARDOUS VOLTAGE PRESENT WITHIN THE UNIT AND AT THE RF OUTPUT CONNECTOR – RISK OF ELECTRICAL SHOCK AND RADIO FREQUENCY ENERGY BURN.**



**CAUTION!**



**ELECTRICAL SHOCK AND RF VOLTAGE  
HAZARD PRESENT INSIDE UNIT AND AT RF  
OUTPUT CONNECTOR.  
DO NOT REMOVE COVERS.  
REFER SERVICING TO QUALIFIED SERVICE  
PERSONNEL.**

## **MM-Series Manual Matching Network Features**

The MM-Series Manual Matching network is designed for use in conjunction with a Radio Frequency power supply as a component in an RF power delivery system for plasma processing or Radio Frequency processing applications.

The Radio Frequency power supply, interconnecting cable(s), and other accessories are sold separately.

The MM-Series Manual Matching Network consists of two variable capacitors and a single fixed inductor. The matching network circuit topology is an "L" type. The type "L" circuit configuration provides a wide tuning range and low insertion loss, delivering maximum power transfer to the Plasma Load.

The variable capacitors within the MM-Series Manual Matching Network are manually positioned by knobs located on the front panel.

### Other MM-Series Matching Network Features:

- Wide tuning range, custom tuning ranges available
- Generic Application, Sputter Application, or custom configurations available.
- Low loss type "L" circuit topology
- Compact Size
- ½-Rack mounting option available
- 300 Watts (MM-300, MM3X) or 600 Watts (MM-6) nominal input power
- Internal DC Voltage probe with selectable polarity
- Convection Cooled
- HN female output connector, other connector configurations available
- 3-Position Source Selector Switch (optional)
- Cost-effective solution for applications that do not require automatic impedance matching

**PHYSICAL DIMENSIONS**

Dimensions in Inch [mm]

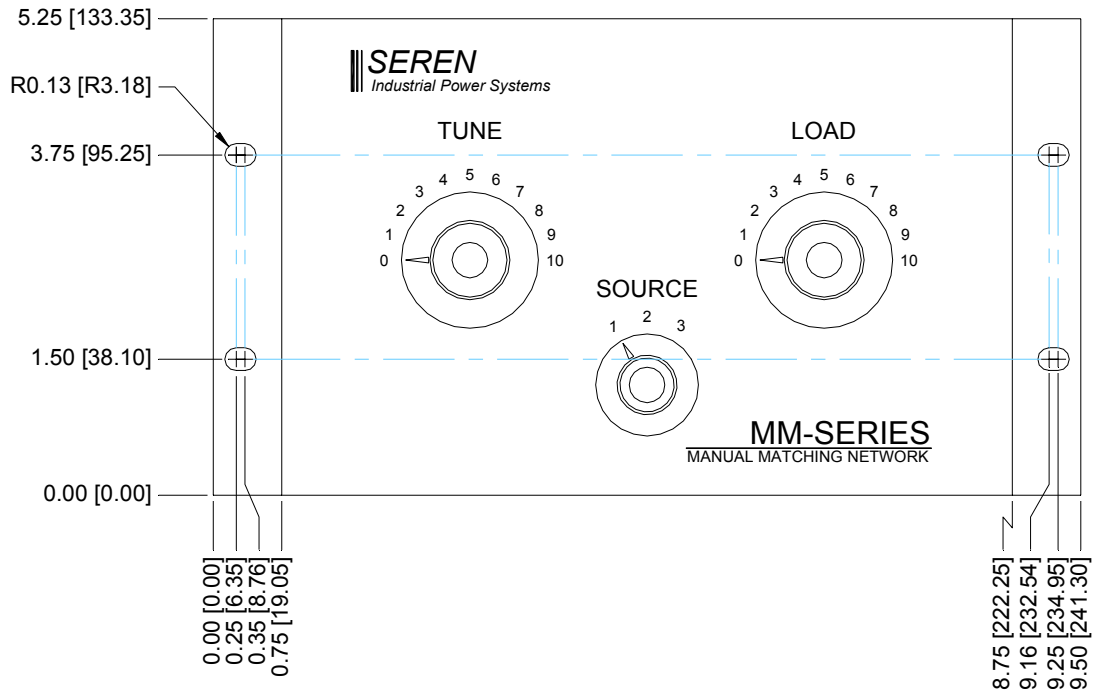

**Front Panel View, MM-Series Matching Network**

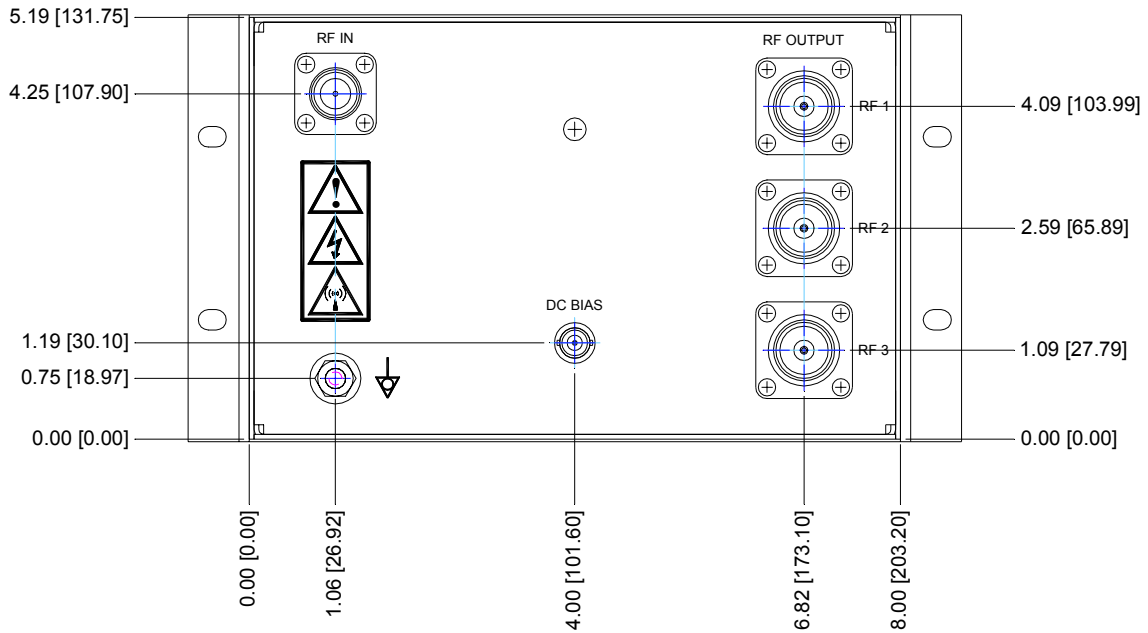

**Rear Panel View, MM-Series Matching Network**

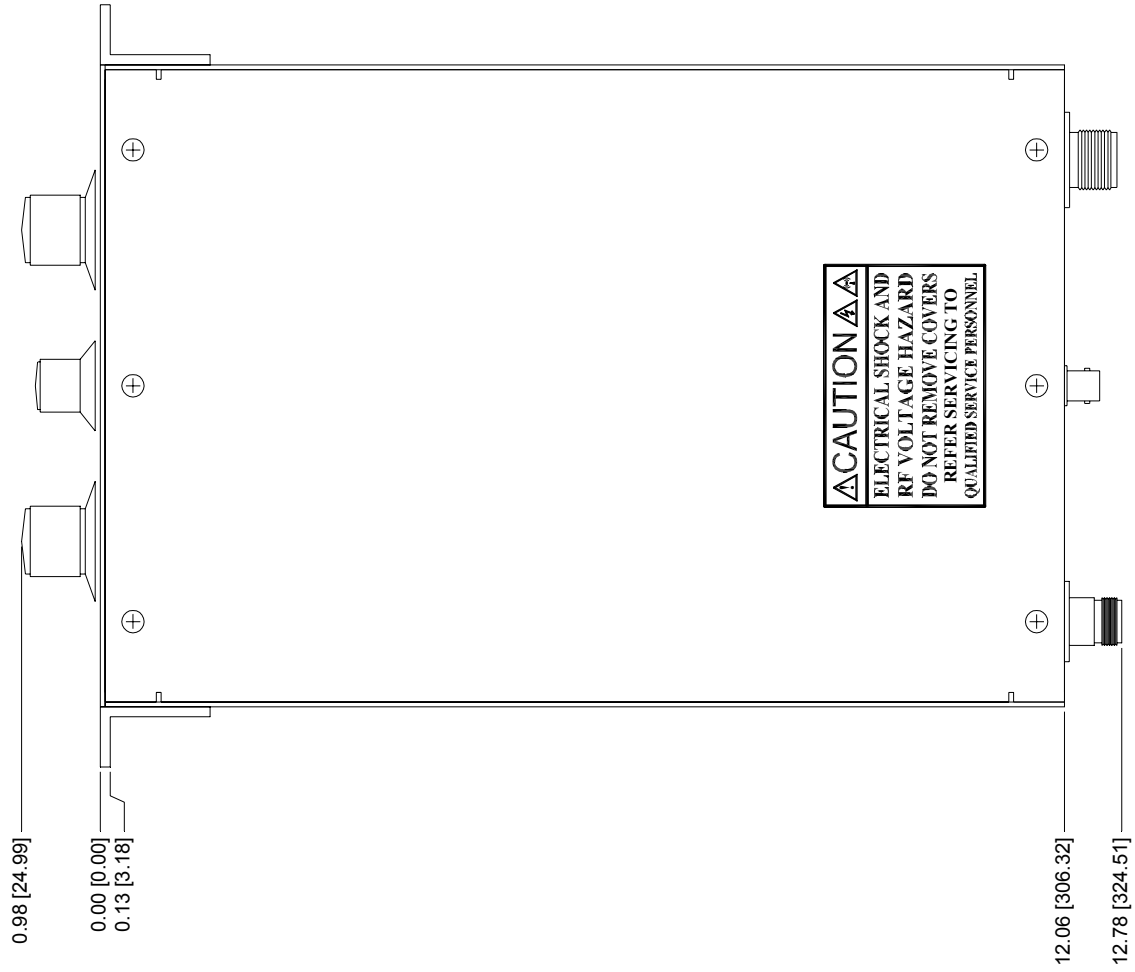

Top Panel View, MM-Series Matching Network



**CONTROLS and CONNECTIONS:**

The MM-Series Manual Matching Networks have simple operator controls, located on the front panel. The controls are diagrammed below:

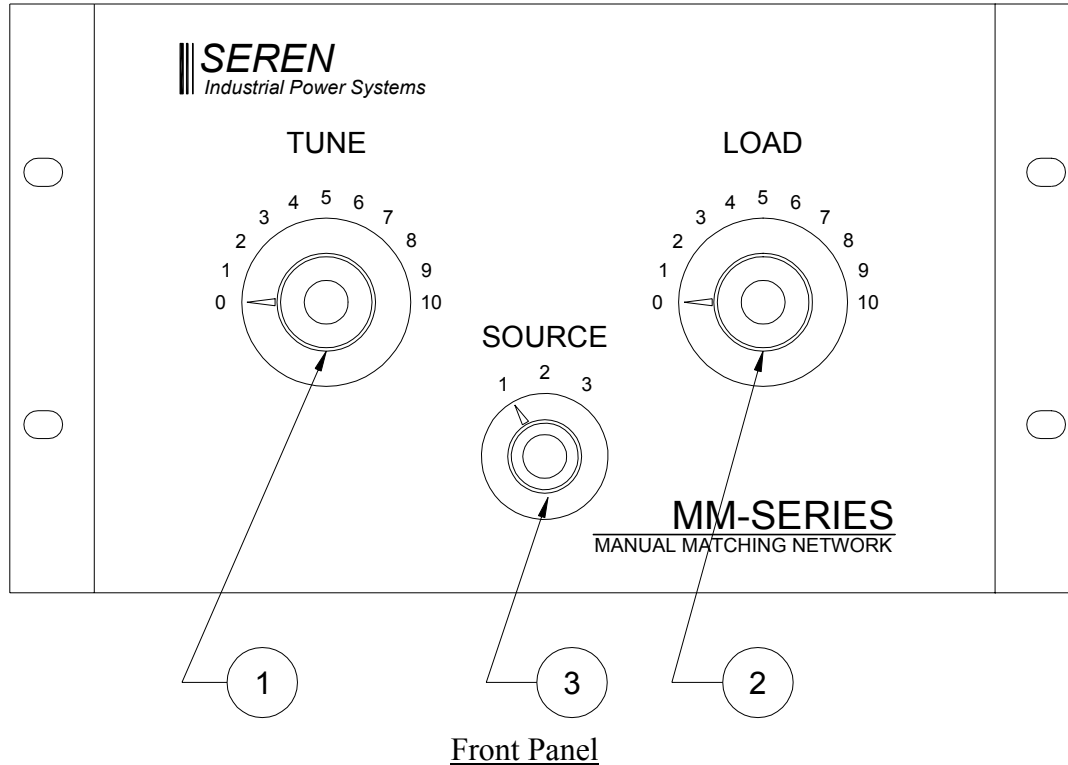

Item	Description
1	<p>Tune Capacitor Adjustment Knob</p> <p>Turn counter-clockwise to decrease capacitance, Clockwise to increase capacitance.                      "0" is Minimum Capacitance (capacitor plates completely un-meshed)                      "10" is Maximum Capacitance (capacitor plates completely meshed)                      Note: Knob will rotate 360°</p>
2	<p>Load Capacitor Adjustment Knob</p> <p>Turn counter-clockwise to decrease capacitance, Clockwise to increase capacitance.                      "0" is Minimum Capacitance (capacitor plates completely un-meshed)                      "10" is Maximum Capacitance (capacitor plates completely meshed)                      Note: Knob will rotate 360°</p>
3	<p>3-Position Source Selector Switch (optional)</p> <p>Routes the MM-Series Manual Matching Network's output to the rear panel RF1, RF2, or RF3 RF Output connector.</p> <p><b><u>DO NOT</u> change switch setting when RF power is applied to the matching network.</b> Internal damage to the matching network or RF Power source may result.</p>

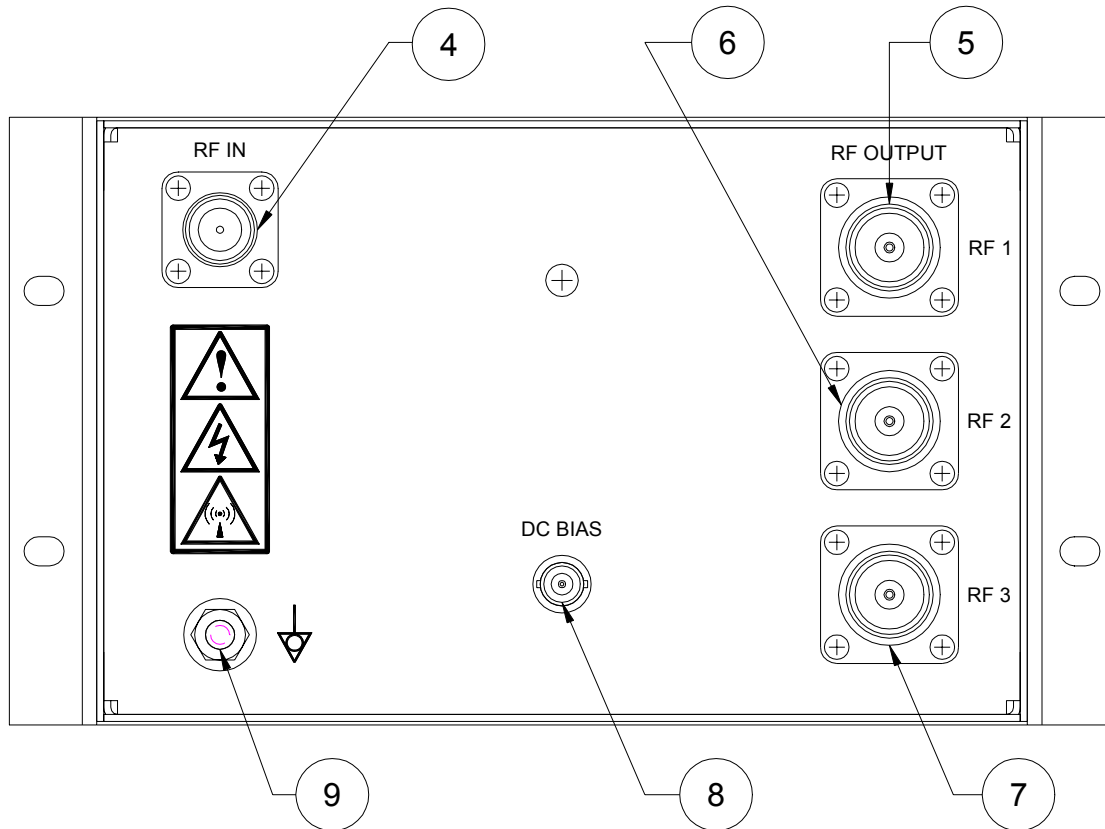

Rear Panel

Item	Description
4	<p>RF Input Connector</p> <p>Coaxial type "N" female. Center pin is RF 'Hot', internally connected to the load capacitor and the series inductor. The threaded shell is RF Return, connected to the MM-Series Matching Network chassis.</p>
5	<p>RF Output Connector #1</p> <p>Coaxial connector, Type "HN" female.</p> <p>Units without source selector switch option: Center pin is "RF" hot, internally connected to the Tune (series) capacitor. The threaded shell is RF Return, connected to the MM-Series Matching Network chassis.</p> <p>Units with source selector switch option: Center pin is "RF" hot, internally connected to the Tune (series) capacitor when the source selector switch is set to the "1" position. The threaded shell is RF Return, connected to the MM-Series Matching Network chassis.</p>

MM-SERIES MANUAL MATCHING NETWORK OPERATOR'S MANUAL	
---	--

6	<p>RF Output Connector #2 (Units with Source Selector Switch Option only)</p> <p>Coaxial connector, Type "HN" female. Center pin is "RF" hot, internally connected to the Tune (series) capacitor when the source selector switch is set to the "2" position. The threaded shell is RF Return, connected to the MM-Series Matching Network chassis.</p>
7	<p>RF Output Connector #3 (Units with Source Selector Switch Option only)</p> <p>Coaxial connector, Type "HN" female. Center pin is "RF" hot, internally connected to the Tune (series) capacitor when the source selector switch is set to the "3" position. The threaded shell is RF Return, connected to the MM-Series Matching Network chassis</p>
8	<p>DC Bias Probe Output</p> <p>Coaxial Connector, Type "BNC" Female. Center pin is "probe output". The connector shell is return, connected to the MM-Series Matching Network chassis. The DC Bias Probe attenuation factor is 200:1. Probe polarity is negative (-).</p>
9	<p>Equipotential Bonding Terminal</p> <p>¼-20 x 1" long stud, supplied with 2 washers and a hex nut. Directly connected to the MM-SERIES matching network's chassis. Connect to the plasma chamber frame ground or system frame ground and the RF Power Supply's Equipotential bonding terminal or chassis with a 2" or wider piece of silver plated copper strap. Keep strap connections as short as possible. Used to minimize RF circulating currents within a processing system.</p>

**UNPACKING:**

Remove the MM-Series Matching Network from its carton and packing materials. Examine the unit for physical damage. If physical damage is evident, notify both the carrier and Seren IPS, Inc. Contact the Seren IPS Inc. service department or a Seren IPS Inc. service representative for assistance.

**INSTALLATION:**

Recommended Accessories (purchased separately)

Consult with your local Seren IPS Inc. sales or service representative to obtain accessory items appropriate for your application and matching network configuration.

Item	Description	Seren Part Number
RF Input Cable	Coaxial, Type RG-213, Type "N" Male to Type "N" Male, 12-Foot (3.66m) Length	9000010144
RF Output Cable	Coaxial, Type RG-393/U, Type "HN" Male to Type "HN" Male 3-Foot (.91m) length	9000020036

Physical Mounting of the MM-Series Matching Network

Mount the MM-Series Matching Network on the plasma chamber or as close as possible to the plasma chamber. Ensure the side panel vent holes are not blocked or obstructed. Ensure there is a proper RF ground connection (equipotential bonding) between the plasma chamber and the matching network. If the matching network is not physically mounted to the plasma chamber, an equipotential bonding (GROUND) strap must be installed.

Grounding (equipotential bonding) of the MM-Series Matching Network

A solid electrical bond between the matching network's chassis and the plasma chamber's chassis is essential for proper operation and safety. A poor bond may result in erratic matching network performance and an electrical shock or RF burn hazard



**IF THE MM-SERIES MATCHING NETWORK CHASSIS IS NOT DIRECTLY BOLTED/ELECTRICALLY BONDED TO THE PLASMA CHAMBER, A BONDING (GROUND) STRAP IS REQUIRED.**

Equipotential bonding straps can be constructed of 0.020" (0.5mm) thick by 2" (50.8mm) (or wider) Copper strap, preferably silver-plated to enhance conductivity and prevent the copper from oxidizing (tarnished copper is not a good RF conductor). Connect the bonding strap from the MM-Series Matching Network's rear panel equipotential bonding terminal to the plasma chamber chassis.

Bonding straps should be as short in length and as wide as possible. Due to operation at 13.56 MHz, the majority of the RF current flows on the surface of the bonding strap (Skin Effect). The more surface area, the better the RF bonding connection. If a single chamber bonding (ground) point is not available, a star-bonding (ground) configuration is recommended.

**Do not daisy chain bonding connections.**

#### Connecting the MM-Series Matching Network Outputs

Connect the rear panel RF Output RF connector(s) to the plasma chamber, via coaxial cables. Keep the length of the coaxial cable as short as possible.

The plasma chamber can present low-impedance, high current and/or high impedance, high voltage loads to the MM-Series matching network's output. RG-393/U or RG-225/U coaxial output cable is recommended for its high-voltage and high temperature properties. Depending on your application, non-Teflon dielectric coaxial cable types may melt or internally arc.

The MM-Series matching network utilizes a type "HN" connector for RF output. This is intended to prevent accidental swapping of input and output cables during installation.

#### Connecting the MM-Series Matching Network RF Input

Connect the matching network's RF Input connector to the RF power source's (RF Generator) RF output connector with a suitable coaxial cable. Coaxial cable types RG-213/U, RG-393/U, or RG-225/U are recommended.

The RF input cable is, electrically, a component of the matching network. The RF input cable length can affect the matching network's performance and ability to match the load impedance. A 12-foot (3.66m) cable length is recommended for initial system set-up, and is often sufficient for most applications. Optimum cable length for your application must be empirically determined.

## OPERATION

Refer to the RF Generator operator's manual for operational details.

### Matching Network "Cold" Setup

1. Set the Tune capacitor position to the mid-range (5) position.
2. Set the Load capacitor position to the mid-range (5) position

### Matching Network First-Use Tuning



1. Enable the RF Generator's AC Mains power.
2. Set the RF Generator's power setpoint to 50 Watts and enable the RF output.
3. Observe the RF generator's reflected power display. Very slowly, rotate the LOAD knob and determine if the reflected power increases or decreases. Adjust the LOAD knob until the reflected power is as low as possible.
4. Continue to observe the RF generator's reflected power display. Very slowly, rotate the TUNE knob and determine if the reflected power increases or decreases. Adjust the TUNE knob until the reflected power is as low as possible.

**Note:** The TUNE adjustment is very sensitive – a slight adjustment can make a large difference in reflected power.

5. Repeat steps 3 and 4 until reflected power is as close to 0 Watts as possible. Typically, 5 Watts or less of reflected power is acceptable.
6. Increase the RF generator's power output to 50% of the desired process power. Repeat steps 3, 4, and 5.
7. Increase the generator's power output to the desired process power. Repeat steps 3, 4, and 5.
8. Note the TUNE and LOAD knob's positions. Leave the TUNE and LOAD knobs in their current positions for process use.
9. Disable the RF Generator's RF output.

End of First-Use tune.

**Should adjustments be required to optimize the MM-Series Matching Network to your plasma reactor or process, refer to "Range Configuration" in the Problem Solving section.**

Matching Network Operation after First-Use Tune:



1. Unless otherwise required for process purposes, leave the TUNE and LOAD knobs as positioned in step 8 in the previous section.
  2. Enable the RF Generator's AC Mains.
  3. Set the RF Generator for the desired power output.
  4. Enable the RF Generator's output.
  5. Observe the RF Generator's forward and reflected power display – ensure the reflected power is less than 10 Watts (or what has been deemed acceptable for the process).
  6. If needed, adjust the TUNE and LOAD knobs to obtain the lowest reflected power possible.
  7. Execute the process.
  8. Disable the RF Generator's RF output.
- End.

## **TECHNICAL DATA**

### **Ratings and Specifications**

RF Input Power	MM300, MM3X: 300 Watts Nominal, application dependant MM6: 600 Watts Nominal, application dependant
Frequency	13.56 MHz
Connections:	RF Input: Type N female RF Output: MM300, MM6: Type HN Female, Qty: 1 MM3X: Type HN Female, Qty: 3 DC Probe Output: Type BNC Female, Qty: 1 Equipotential Bonding Terminal: ¼-20 x 1" Stud, Qty: 1
Environmental:	Operating Ambient: 10°C to 40°C Humidity: 80% maximum, non-condensing
Cooling:	Convection
Matching Elements: (Standard Configurations)	MM300 (Seren P/N 9400210001) MM3X (Seren P/N 9400220000) Load Capacitor Range (Variable): 22-822pF Fixed Loading Capacitors: None Tune Capacitor Range(Variable): 17-178pF RF Coil: 12 Turn  MM6 (Seren P/N 9400230000): Load Capacitor Range (Variable): 22-822pF Fixed Loading Capacitors: 240pF x1 Tune Capacitor Range (Variable): 24-163pF RF Coil: 7 Turn
DC Bias Probe:	DC Voltage, 200:1 Attenuation (Standard), Negative (-) Polarity
Package Dimensions: Inch (mm)	With Rack Ears: 5.25(133.3)H x 9.50(241.3)W x 12.06 (306.3) Without Rack Ears: 5.25(133.3)H x 8.00(203.2)W x 12.06 (306.3) Dimensions exclude front panel knobs and rear panel connectors.
Weight	6.5 Lbs. (2.95 Kg)



Tuning Range, MM300 Manual Matching Network

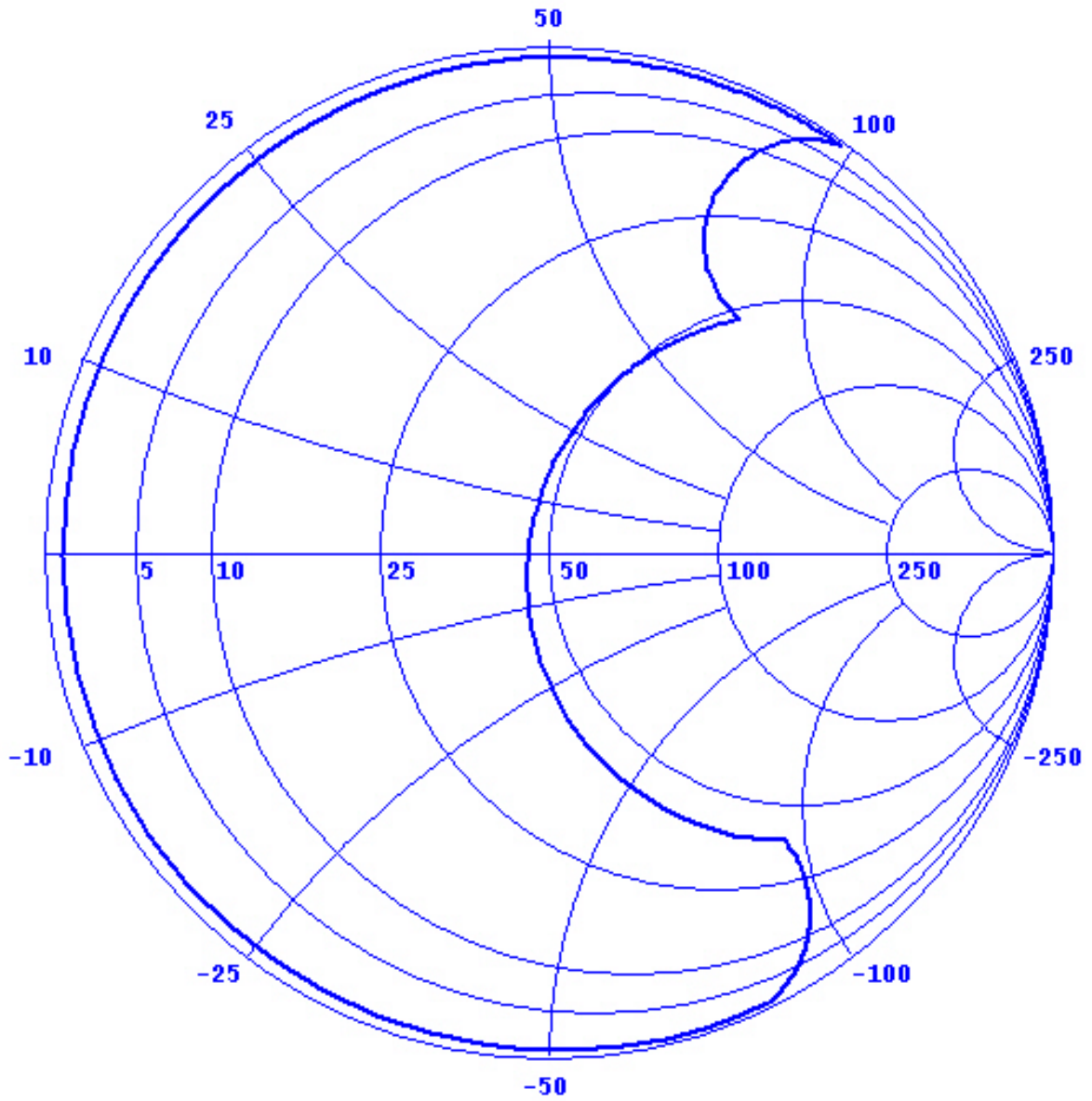

Tuning Range, MM3X Manual Matching Network:

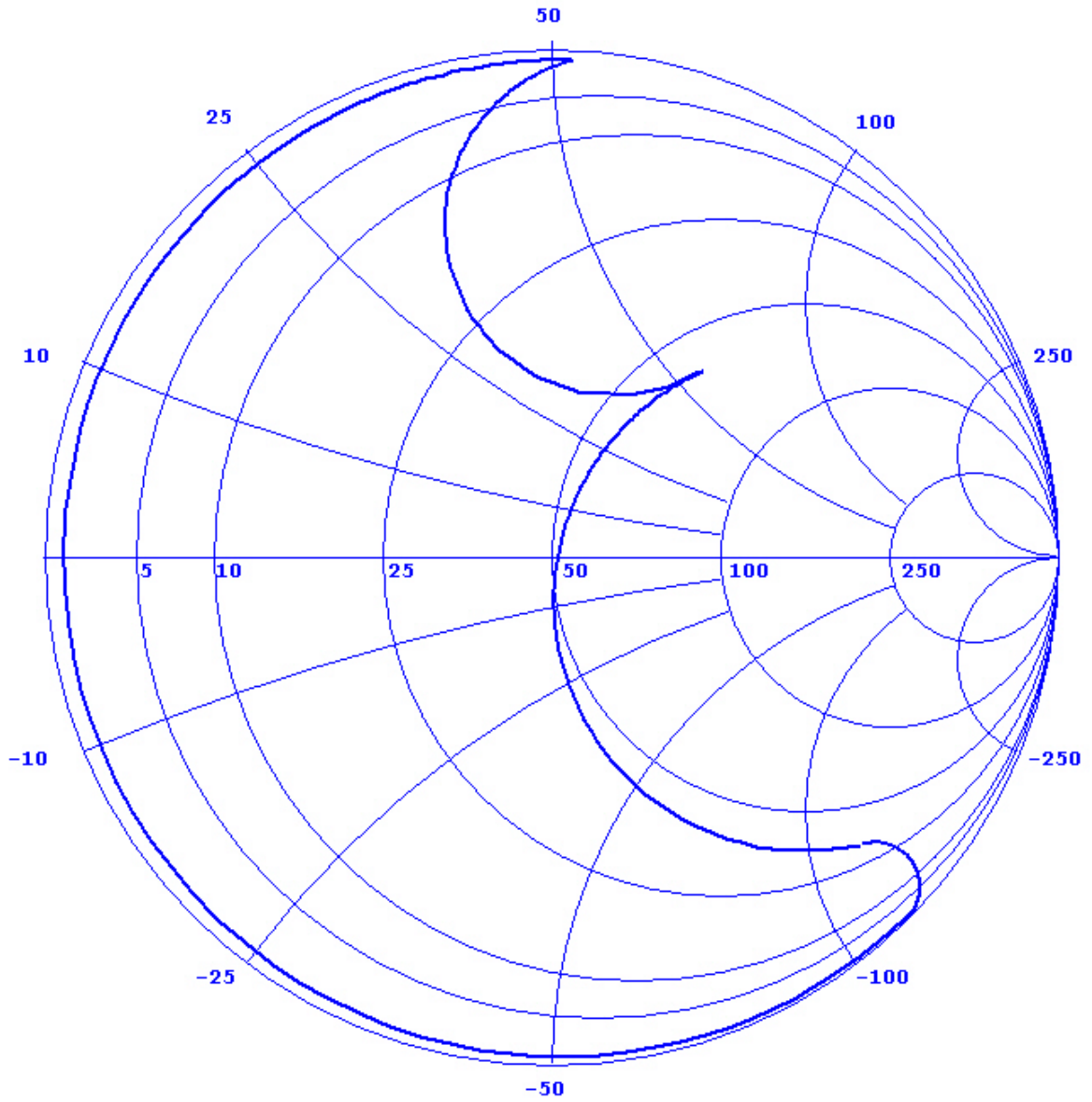

Tuning Range, MM6 Manual Matching Network:

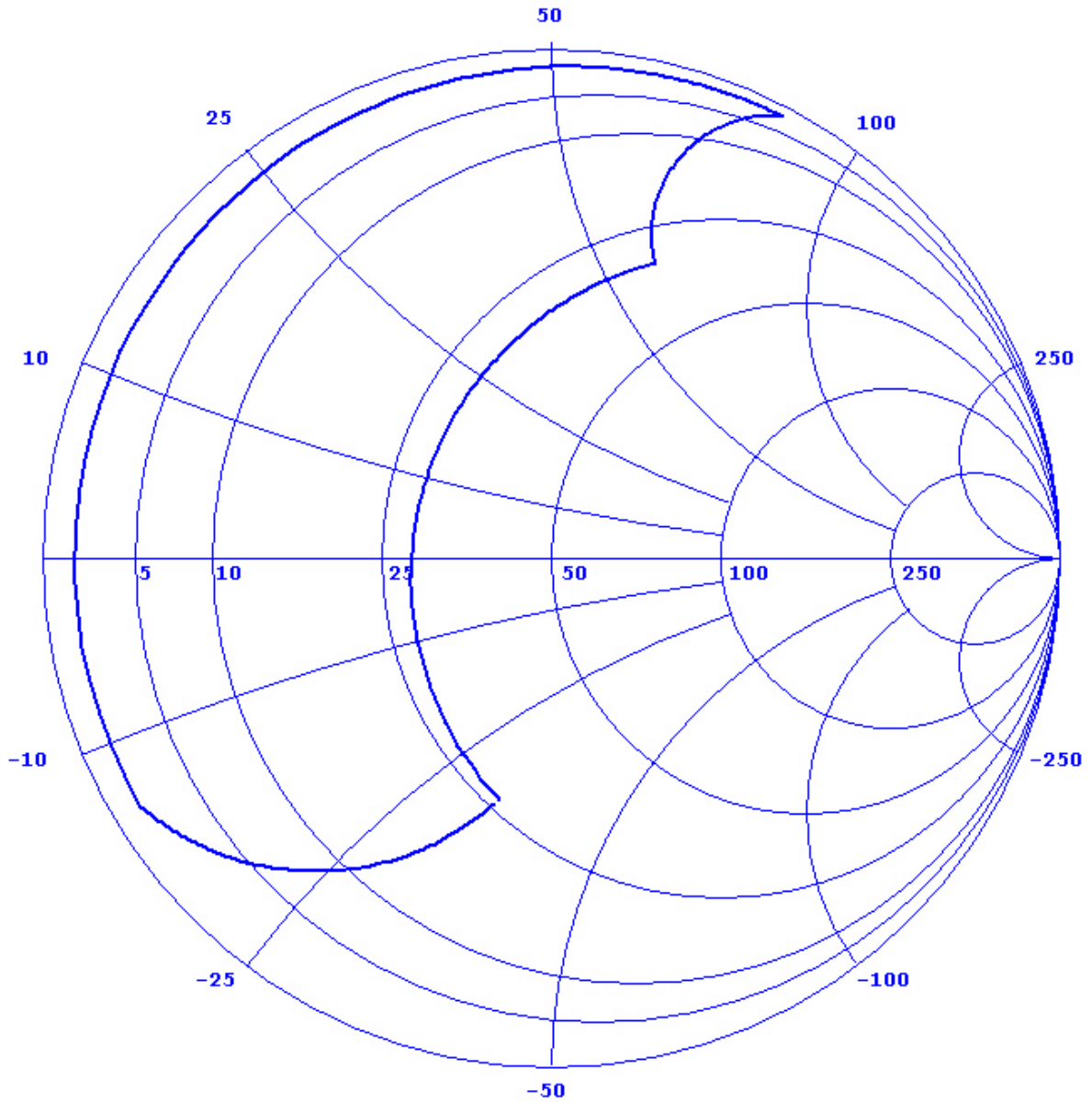

## **Theory of Operation**

The function of the MM-Series Manual Impedance Matching Network is to manually transform the plasma impedance from a mismatched condition to 50 Ohms. This is accomplished by the using passive components with high voltage and current ratings, configured in a basic type "L" configuration.

### Loading and Plasma Impedance:

The shunt or Load elements are connected from the RF input to chassis ground. The loading component is used to drive the plasma impedance to 50 ohms and is accomplished through the use of an air variable capacitor. Depending on the model and application, additional fixed capacitors may be connected in parallel with the load variable capacitor.

### Tuning and Plasma Reactance:

The series or Tune elements work together to counteract the reactive component of the plasma impedance. Seren AT-Series matching networks utilize a fixed inductor in series with a air variable capacitor to counteract the plasma reactance.

### DC Voltage Probe:

A 200:1 DC Voltage probe is included within the MM-Series Matching Network. The probe provides a means to measure the developed DC Voltage within the chamber. The DC Voltage probe's output signal is proportional to the developed DC within the chamber.

The DC Voltage probe's output can be used by the processing system to monitor plasma chamber status and/or used as a power regulation feedback signal for the RF generator. Using the DC Voltage probe output for a power regulation feedback signal is commonly referred to as DC Voltage Control. Seren IPS Inc. RF Generators can operate in DC Voltage control mode.

The DC Voltage developed within the chamber has a negative (-) polarity. The DC Voltage probe has a negative polarity output.

**Chassis Schematics:**

Chassis Schematics for the MM300, MM3X, and MM6 are show below. Other configurations are possible, on a custom-order basis. Contact the Seren IPS Inc. factory or a Seren IPS Inc. service representative for information regarding other application configurations.

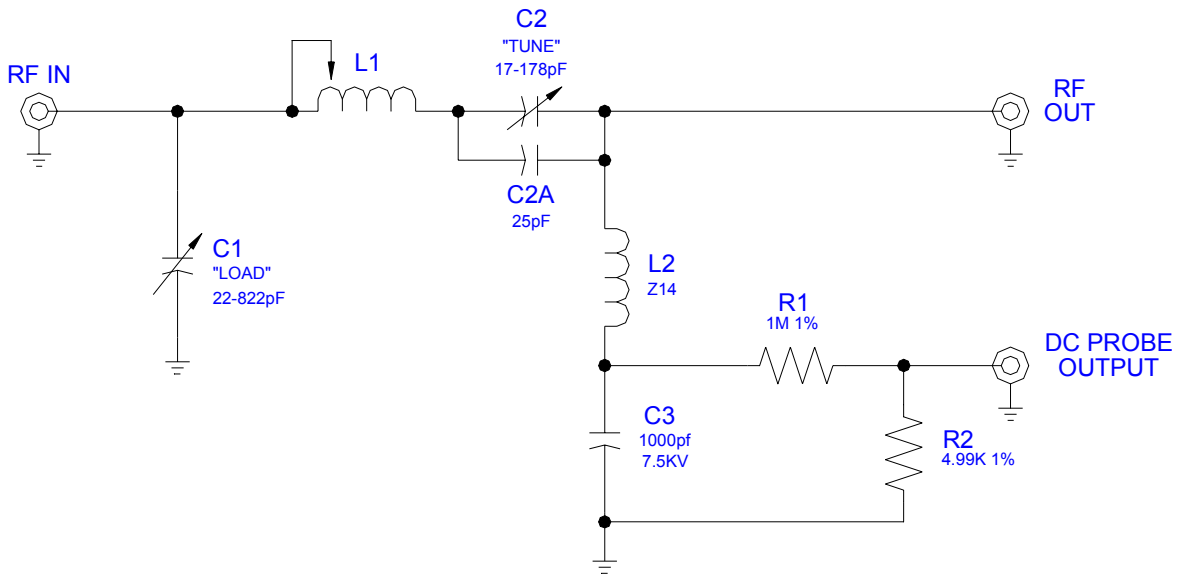

Chassis Schematic, MM300

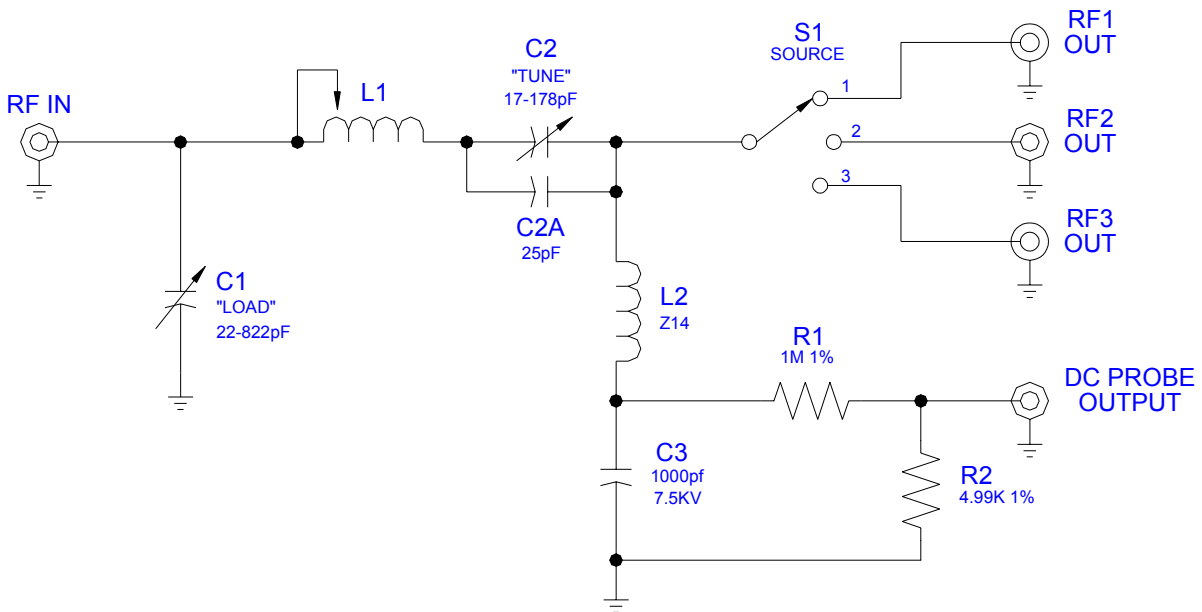

Chassis Schematic, MM3X

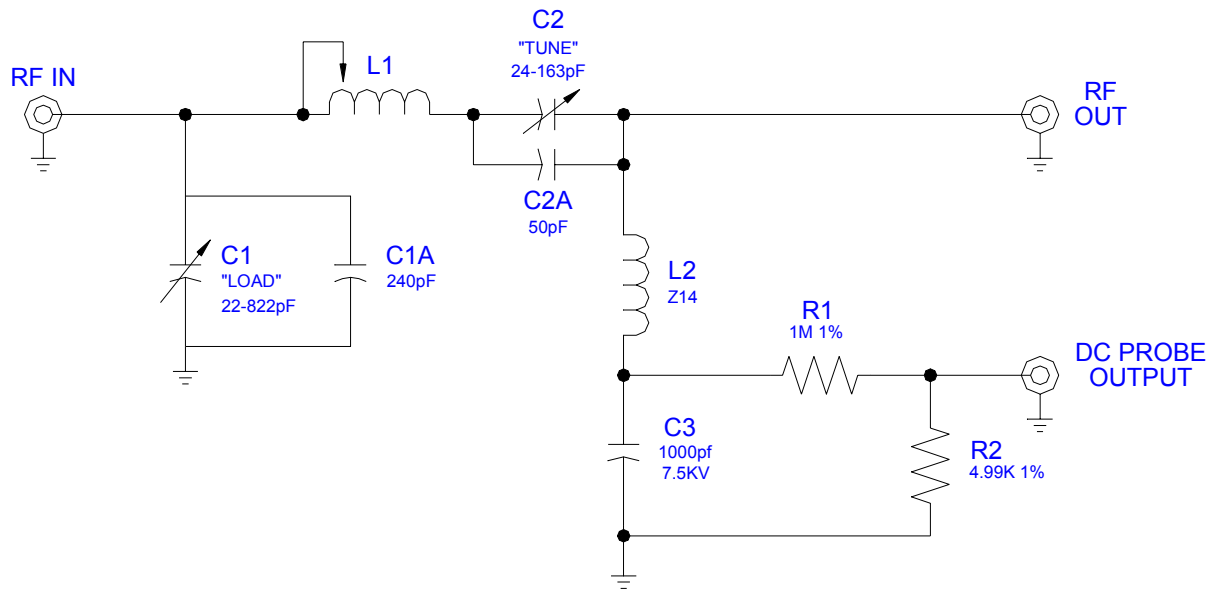

Chassis Schematic, MM6

### Typical System Configuration

A typical system configuration is shown below. The basic configuration consists of an MM-Series matching network, an RF Power source (generator), and a load. In this configuration, the matching network operates independently from the RF power source and load/processing system.

Other configurations and wiring schemes are possible. For assistance with system wiring schemes, contact the customer service department or a Seren IPS Inc. service depot. Coaxial cables, RF generators, and system equipment are not supplied with the MM-Series Matching Network.

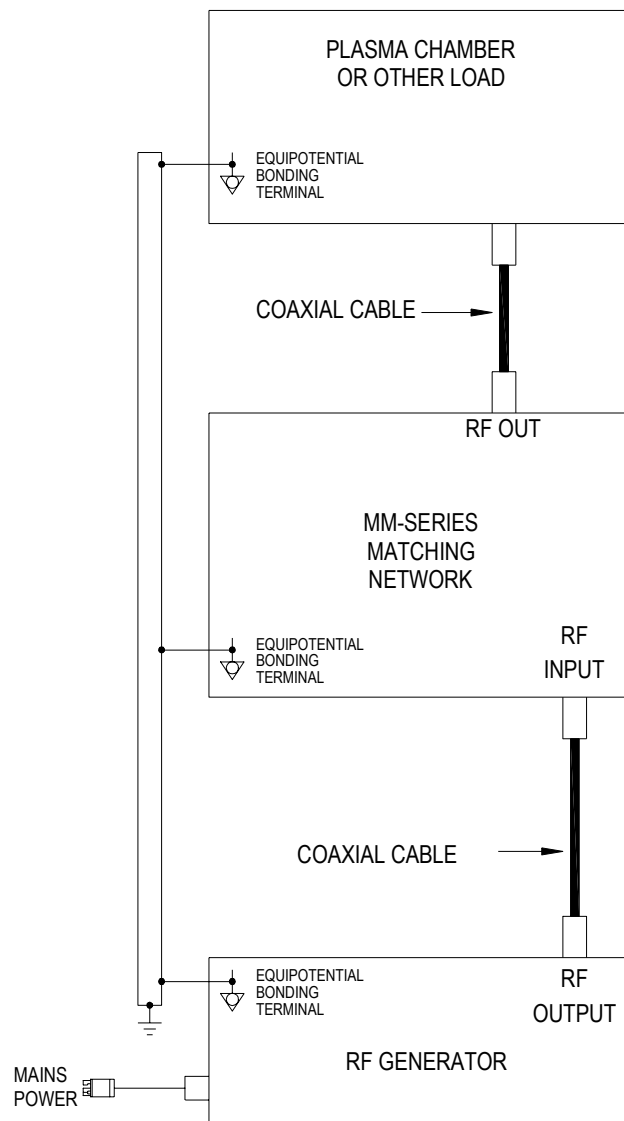

Typical System Configuration

**MAINTAINENCE:**

The MM-Series Manual Matching Network is designed to be maintenance free. There are no user maintainable assemblies inside the unit. The MM-Series is designed for use in a clean environment. Periodically check the air vents for accumulation of dust and debris. Clean the air vents with a vacuum cleaner if they appear dirty or clogged.



Restricting the air vents or installing the MM-Series Manual Matching Network in a dusty environment may impact the long-term reliability of the matching network. Severe dust contamination can clog the Load and Tune capacitors and cause internal arcing.

Cleaning:

**DO NOT** clean the MM-Series Manual Matching Network when RF power is applied to the matching network. The exterior of the matching network may be cleaned with a soft cloth, dampened with soap and water or a mild solvent, such as alcohol.



**PROBLEM SOLVING**

*Problem Solving Chart*

The following chart lists some conditions that may occur and the recommended solutions. Follow the suggested solutions until the problem is corrected. If the problem persists, please contact Seren IPS Inc. customer service or a Seren IPS Inc. service representative.

Condition	Suggested Solutions
<p>The Generator's reflected power display is the same as the generator's forward power.</p>	<p>Adjust the MM-Series matching network's Tune and Load knobs.</p> <p>On a MM3X Manual Matching network, check the position of the source selector switch. Ensure the selector switch is set properly. Consult system provider's documentation.</p> <p>Ensure the generator's RF output cable is connected to the MM-Series Matching Networks RF Input Connector.</p> <p>Ensure the load is properly connected to the RF output connector.</p>
<p>The load used to be matched, but over a period of time, the match has drifted – reflected power has increased.</p>	<p>Over time, deposits can build up on the inside of a plasma chamber. The deposits change the chamber's impedance.</p> <ol style="list-style-type: none"> <li>1. A slight re-adjustment of the matching network's Tune and Load Knobs may be needed to restore the match.</li> <li>2. The plasma chamber may need to be cleaned. Consult the system documentation for chamber cleaning details.</li> <li>3. Check the coaxial cable between the MM-Series Matching network and the load – the coaxial cable may have failed or melted.</li> </ol>
<p>The load was tuned, but when the generator's forward power is increased, the reflected power increases.</p>	<p>The MM-Series Manual Matching Networks are not capable of automatic tracking.</p> <ol style="list-style-type: none"> <li>1. A slight adjustment of the Load knob may lower the reflected power.</li> <li>2. If the match improved, but is still not acceptable, a slight adjustment of the Tune knob may lower reflected power. Note: the Tune adjustment is very sensitive.</li> </ol>
<p>The load was tuned, but when the generator's forward power is decreased, the reflected power increases.</p>	<p>The MM-Series Manual Matching Networks are not capable of automatic tracking.</p> <ol style="list-style-type: none"> <li>1. A slight adjustment of the Load knob may lower the reflected power.</li> <li>2. If the match improved, but is still not acceptable, a</li> </ol>

Condition	Suggested Solutions
	slight adjustment of the Tune knob may lower reflected power. Note: the Tune adjustment is very sensitive.
The matching network can tune the load, but reflected power cannot be tuned to Zero (0) Watts.	<ol style="list-style-type: none"><li data-bbox="667 323 1414 432">1. Increase or decrease the length of coaxial cable between the RF generator and the MM-Series matching network. Use 1 foot (304mm) increments.</li><li data-bbox="667 449 1414 558">2. Increase or decrease the length of coaxial cable between the MM-Series matching network and the load. Use increments of 6 inches (152mm) or less.</li><li data-bbox="667 575 1414 684">3. The matching network's range configuration may need adjustment. See the "Range Configuration" heading in the Problem Solving section</li></ol>

Range Configuration

Unless otherwise specified at the time of order, the MM-Series Manual Matching network is shipped with a “generic” range configuration. On some systems, the generic range configuration may be insufficient to obtain a matched (0 Watts Reflected power) condition. Refer to the chart below to adjust the matching network's range.

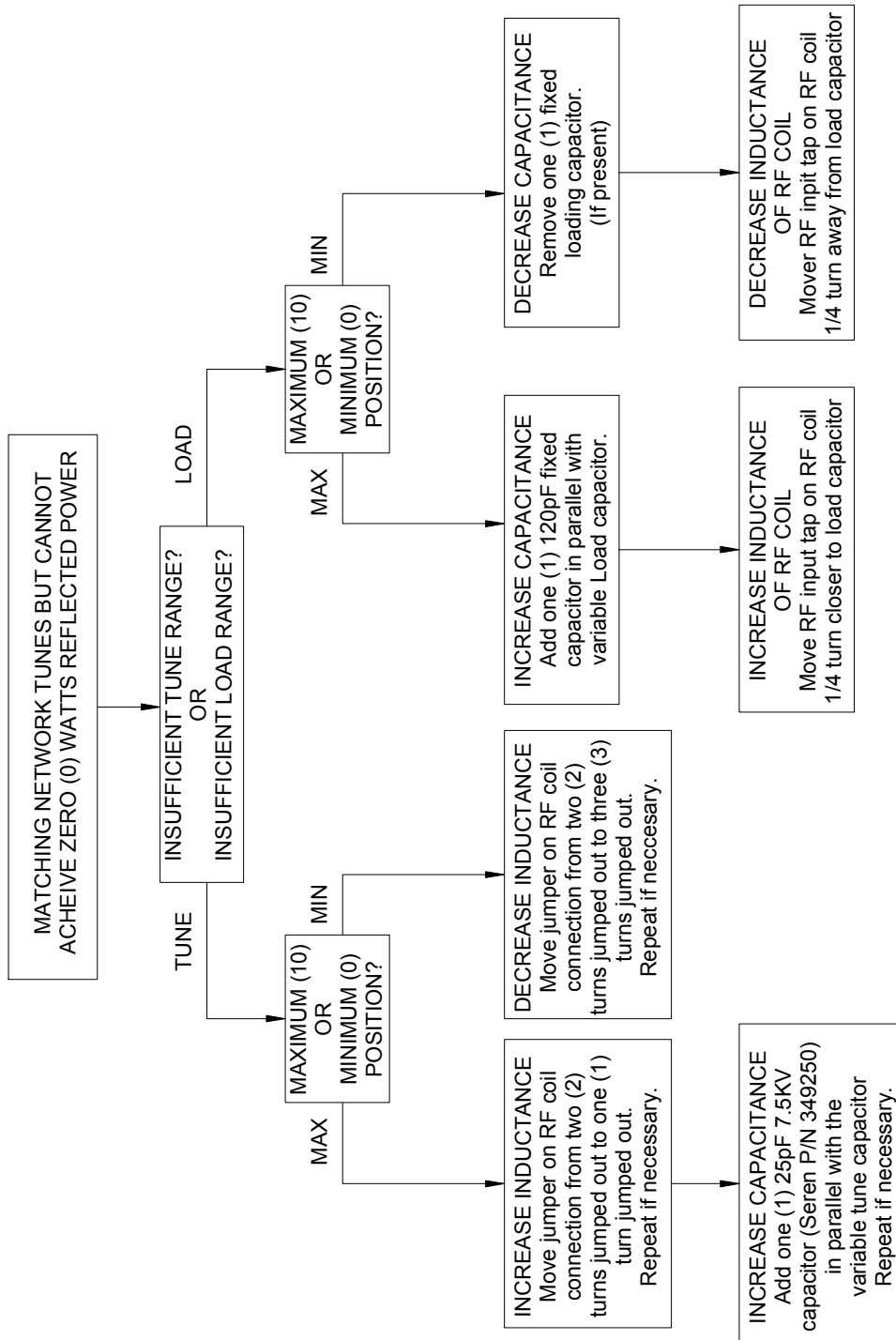

## **SEREN 1 Year Limited Warranty**

SEREN IPS Inc. products are warranted to the original purchaser against defects in material and workmanship for a period of one year from the date of delivery.

SEREN IPS Inc. will repair or replace, at its option, all defective products returned freight prepaid during the warranty period, without charge, provided that there is no evidence the product has been mishandled, abused, or misapplied. Our liability under this warranty is limited to servicing, repairing, or replacing any defective products for a period of one year after delivery to the original purchaser.

If warranty service is required, the equipment must be returned, transportation charges prepaid, to our factory or authorized service depot. In the case of misuse, abnormal operating conditions, or other non-warranty work, a repair cost estimate will be submitted for approval before work is started.

### WHAT THE WARRANTY DOES NOT COVER:

This warranty covers only defects in materials and workmanship provided by SEREN I.P.S. and does not cover equipment damage or malfunction from misuse, abuse, accident, act of God, non-SEREN I.P.S. modification or upgrade. Improper return shipping, packaging, or shipping damage is not covered. SEREN I.P.S. will not be liable for any incidental or consequential damages resulting from your use of, or inability to use your Matching Network.

### IF YOU HAVE A PROBLEM

The first step is to contact your system vendor. Consult with your system vendor to determine the nature of the problem. Your system vendor knows the intimate details of how your processing system interfaces and operates with the MM-Series Manual Matching Network and can efficiently resolve system related problems.

If it is determined that the Matching Network has a problem, contact the nearest Seren IPS service representative or our customer service department at 1-856-205-1131. Before you call, please be ready to provide the model number of your Matching Network, its serial number, date of manufacture, a description of the problem, and the model and manufacturer of the processing system it is used on.

### HOW IS WARRANTY SERVICE OBTAINED?

Our customer service representative will explain how to obtain service under this warranty. Please save the original packing materials in order to facilitate shipment.

## Glossary of Terms

A	Amperes, a measurement unit of current
AC	Alternating Current
Chamber	Industry term for a vacuum chamber used in plasma processing equipment.
D-Sub	Industry term for D-Subminiature connector
DC	Direct Current
Equipotential Bond Equipotential Bonding	Equipotential bonding (often referred to as grounding) is used to control RF circulating currents within a system. For regulatory purposes, it is not a "Protective Earth" or "Safety Ground", even though it may be bonded to the "Protective Earth" or "Safety Ground" within the equipment or user's facility.
KHz	Kilo Hertz, a measurement unit of frequency (1000 Hertz)
KVA	Kilo Volt-Amperes
Load Capacitor	Industry term for a shunt capacitor in an "L" type impedance matching network. Can be fixed or variable type.
Matchbox	Industry term for an impedance matching network
MHz	Mega Hertz, a measurement unit of frequency (1,000,000 Hertz)
mV	Milli-Volts, a measurement unit of Voltage, equal to 1/1000 of a Volt.
RF Generator	Industry term for Radio Frequency Power Supply
RF	Radio Frequency
Strike Preset	A pre-determined (usually empirically) starting positions for the matching network's capacitors – an aid for plasma ignition.
Tune Capacitor	Industry term for the series capacitor in an "L" type impedance matching network. Can be fixed or variable type.
Tuner	Industry term for an impedance matching network
VAC	Volts, Alternating Current
VDC	Volts, Direct Current
W	Watts

**Revision History**

<b>Revision</b>	<b>Date</b>	<b>Revision Description</b>
1.00	8/11/04	Issued