

SEREN

INDUSTRIAL POWER SYSTEMS INC.

RX01/LX01 SERIES RADIO FREQUENCY POWER SUPPLY

OPERATOR'S MANUAL

Revision: 2.03
Standard Configuration

Document Number 6100220000

SEREN Industrial Power Systems, Inc.
1670 Gallagher Drive
Vineland, New Jersey, 08360
U.S.A

Telephone: 856-205-1131
Fax: 856-205-1141
E-mail: info@serenips.com
Web: www.serenips.com

Copyright © 2003-2019 Seren IPS Inc.

This page intentionally blank.

Introduction

Thank you for purchasing your new SEREN IPS product. Seren Radio Frequency Power Supplies are designed to provide the best value, ease of operation, and reliability for plasma processing systems. This manual covers specifications, installation, and operation of the Seren IPS Inc. RX01 and LX01 Series RF Power Supplies.

Information

To get answers for any questions you might have regarding your plasma or processing system, please contact your system vendor first. Your system vendor knows the intimate details of how your equipment interfaces and operates with the RF Power Supply and can efficiently resolve system related problems.

For questions directly related to the RF Power Supply, you may call us, Monday through Friday, 8:00am to 5:00pm, United States Eastern Time, at:

1-856-205-1131

Service

For RF Power Supplies purchased with a processing system, or covered under a service contract from your system vendor, please contact the system vendor to arrange for service.

For after-market or end user customers, a SEREN IPS customer service representative will arrange for service. Call us, Monday through Friday, 8:00am to 5:00pm, United States Eastern Time, at: **1-856-205-1131**

Please note: Equipment returned to us without prior authorization or without a Return Materials Authorization (RMA) number visible on the outside of the package will be refused.

How to Contact Us

Our address, telephone, and fax numbers are listed below.

SEREN Industrial Power Systems, Inc.
1670 Gallagher Drive
Vineland, New Jersey, 08360 U.S.A.

Telephone: 856-205-1131
Fax: 856-205-1141

Proprietary Information Notice

This document contains information proprietary to SEREN IPS Inc. This document shall not be reproduced or its contents disclosed without the written permission of SEREN IPS Inc. This notice shall appear in all copies.

This page intentionally blank.

TABLE OF CONTENTS

Safety Notes	1
Radio Frequency Power Supply Model Features	3
Installation	4
Recommended Mounting	4
Supplied Accessories	4
Ventilation	4
Connection to a Water Cooling System	5
Connecting to Water Inlet/Outlet Ports	5
Coolant Water Temperature and Flow Rate	6
Coolant Water Supply Lines	6
Solenoid Water Valve Installation	7
RF Output Connection	7
Connection to AC Mains	10
System Interfacing	20
Front Panel Controls and Display	21
Operation.....	23
Front Panel Operation	23
Configuring Programmable Parameters	28
Programmable Parameter Reference Chart	28
Programmable Parameter Details.....	36
Analog Interface Operation	77
Serial Interface Operation	79
Serial Communications: RS-232, RS-422, RS-485 Protocols	81
Serial Command Reference Chart	82
Serial Command Reference Chart - MC2 "Pass-Thru" Commands	90
Serial Command Details, RS-232, RS-422, RS-485 Protocols	92
Serial Communications: RS-485 Protocol	119
Overview	119

TABLE OF CONTENTS

How To Configure the RF Power Supply for RS-485 Communications	119
Sending Serial Commands via RS-485	121
Serial Communications: MODBUS Protocol	122
Overview	122
How To Configure the RF Power Supply for MODBUS Communications	123
MODBUS Commands	124
DeviceNet™ Communications (<i>option</i>)	132
DeviceNet Technical Information	132
DeviceNet I/O Poll Command/Response Assembly Data Formats	134
DeviceNet Product Codes and Product Names	156
DeviceNet Serial Number Reporting	156
DeviceNet Electronic Data Sheet (EDS)	157
How to Configure the RF Power Supply for DeviceNet Communications	159
DeviceNet Operation	162
Pulsing Operation	163
Rear Panel Controls and Connections.....	166
R101, R101MKII, R301, R301MKII, L301, L101MKII, L301MKII Rear Panel	166
R601, L601, R1001, L1001 Rear Panel	166
R1001W, L1001 Rear Panel	167
R2001, R2001H, R3001, L2001, L2001H, L3001 Rear Panel	168
R4001 and R5001 (4U Package) Rear Panel	168
R5001, L5001 (5U Package) Rear Panel	169
R10001 Rear Panel	170
R15001 Rear Panel	171
RF Output Connector	172
Power Inlet or Captive Power Cord	172
Mains Circuit Breaker	173
DCP Connector (R101, R101MKII, L101MKII, R301, R301MKII L301, L101MKII, L301MKII Models only)	174
CEX OUT Connector	173

TABLE OF CONTENTS

CEX IN Connector	174
Fan Exhaust	174
Analog Interface Connector	175
Analog Interface Connector Pin List	176
Typical Interface Circuits	183
Typical Analog Interface Connections	186
External Feedback with Probe Inverter Option (Model R101, R101MKII, L101MKII, R301, R301MKII, L301, L301MKII only)	187
Serial Interface Connector.....	189
Serial Interface Connector Pin List	189
Serial Interface Wiring: RS-232	190
Serial Interface Wiring: 4-Wire RS-485 and RS-422	191
Serial Interface Wiring: 2-Wire RS-485	192
Serial Interface Wiring: Serial Pass-Through to Seren IPS MC2 Controller	193
Equipotential Bonding Terminal	196
Valve Connector	197
Valve Connector Pin List	197
Coolant Water IN Port	198
Coolant Water OUT Port	198
DeviceNet Interface Connector and Controls (<i>Optional</i>)	199
DeviceNet Interface Connector	199
DeviceNet Status Indicators	200
DeviceNet Address Switches	200
DeviceNet Data Rate Switch	200
Typical System Configuration	201
Maintenance.....	202
Problem Solving Chart and Front Panel Alarm Messages	203

TABLE OF CONTENTS

Technical Data	211
RF Power Supply Identification	211
Specifications: R101 (Transformer Supply) (Discontinued)	212
Specifications: R101 (Switching Supply) (Discontinued)	216
Specifications: R101MKII	220
Specifications: L101MKII	224
Specifications: R301 (Discontinued)	228
Specifications: R301MKII.....	232
Specifications: L301 (Discontinued)	236
Specifications: L301MKII	240
Specifications: R601	244
Specifications: L601	248
Specifications: R1001	252
Specifications: R1001W	256
Specifications: L1001	261
Specifications: L1001W	265
Specifications: R2001	270
Specifications: R2001H	275
Specifications: L2001	280
Specifications: L2001H	285
Specifications: R3001	290
Specifications: L3001	295
Specifications: R4001	300
Specifications: R5001 (4U Package, Part Number Series 960096XXXX)	305
Specifications: R5001 (5U Package, Part Number Series 960072XXXX and 960086XXXX).....	310
Specifications: L5001 (5U Package)	315
Specifications: R10001 (27MHz 8KW OEM version)	320
Specifications: R10001	325
Specifications: R15001	330
 Physical Dimensions: R101, R101MKII, R301, R301MKII, L301, L101MKII, L301MKII ...	335
Physical Dimensions: R601, L601, R1001, R1001W, L1001	337

TABLE OF CONTENTS

Physical Dimensions: R2001, R2001H, L2001, L2001H, R3001, L3001	339
Physical Dimensions: R4001, R5001 (4U Package)	341
Physical Dimensions: R5001, L5001 (5U Package)	343
Physical Dimensions: R10001	345
Physical Dimensions: R15001	347
Agency Compliance Information	349
Declaration Of Conformity (CE) Models R101MKII, L101MKII, R301MKII, L301MKII	349
Declaration Of Conformity (CE) Models R101, L101, R301, L301 (discontinued)	350
Declaration Of Conformity (CE) Models R601, L601, R1001, L1001	351
Declaration Of Conformity (CE) Models R2001, R2001H, L2001, L2001H, R3001, L3001	352
Declaration Of Conformity (CE) Models R10001, R15001	353
Semiconductor Equipment and Materials International (SEMI)	354
SEREN 1 Year Limited Warranty.....	355
Obtaining Service for your RF Power Supply.....	355
Glossary of Terms.....	356
Revision History.....	358

This page intentionally blank.

Safety Notes

Seren IPS Inc. RF Power Supplies have been designed and tested to meet strict safety requirements. These include independent lab examination and approval, and compliance to established standards. Please read the following instructions carefully before operating the RF Power Supply and refer to them as needed to ensure the continued safe operation of the RF Power Supply.

If the R/LX01-Series RF power supply is used in a manner for which it is not intended, the safety protection provided by the equipment may be impaired.

Follow all warnings and instructions marked on or supplied with the product.

Symbology:

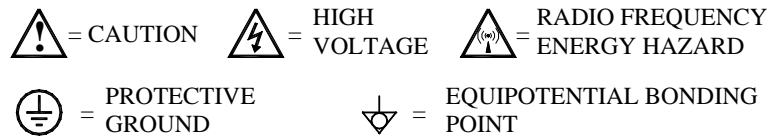

The Operator's Manual / product documentation must be consulted in all cases where the caution symbol is used on the RF power supply.

Unplug or disconnect this equipment from the power source before cleaning or re-configuring the AC mains voltage.

Do not use this equipment near water, wet locations, or outdoors.

Do not place this equipment on an unstable cart, stand, or table. The RF Power Supply may fall, causing personal injury or damage to the RF Power Supply.

This product is equipped with a power cord and grounding type plug. This is a safety feature. To avoid electric shock, this unit must be connected to the power source in compliance with the National Electrical Code ANSI C1 and/or any other codes applicable to the user. Improper installation may result in a shock or fire hazard. Note: Models R10001 and R15001 are not supplied with a power plug. It is the responsibility of the installer to provide a safety ground (protective earth) connection to the power cord in accordance with national and local codes.

It is the responsibility of the installer to provide a proper protective ground from the RF Power Supply to earth ground, in accordance with local and national electrical codes, and any other codes applicable to the user.

The RF Power Supply shall be operated from the type of power source indicated by the ratings plate. If you are not sure of the type of power available, consult an electrician or your local power company.

The power supply cord and plug is the disconnect device for this equipment. If the plug is removed from the cord and the power cord is hard wired to the power source, it is the responsibility of the installer to provide a disconnect device. Note: Models R10001 and R15001 are not supplied with a power plug. It is the responsibility of the installer to provide a disconnect

device in accordance with national and local codes. The power plug or disconnect device must be readily accessible by service personnel.

For SEMI S2 compliance, the system power distribution panel, system integrator, or end-user must supply an over-current protection device (fuse or circuit breaker) with a minimum interrupting capacity of 10,000A (10,000AIC).

For SEMI S8 compliance, the RF power supply must be mounted with the centerline of the front panel display located between 0.0 inches (0.0 cm) and 64.0 inches (162.6 cm) above the floor.

Do not allow anything to rest on the power cord or interconnecting cables. Do not locate the RF Power Supply where persons will step on the power or interconnecting cables.

Slots and Openings in the equipment's chassis are provided for ventilation. To ensure reliable operation of the RF Power Supply, these openings must not be blocked, covered, or restricted. Restricting the air inlets or exhaust will cause the unit to overheat. Sustained over temperature conditions may degrade or damage the unit.

Never push objects of any kind into the slots and openings of the RF Power Supply's enclosure. They may touch dangerous voltage points or short out parts, which could result in a fire or electric shock.

Never spill liquid of any kind on or into the RF Power Supply.

Never remove covers or guards that require a tool for removal. There are no operator serviceable areas within these covers. Refer servicing to qualified service personnel.



CAUTION!



ELECTRICAL SHOCK HAZARD PRESENT
INSIDE UNIT, AT THE RF OUTPUT
CONNECTOR, AND AT THE MAINS INPUT
CONNECTOR.
DO NOT REMOVE COVERS.
REFER SERVICING TO QUALIFIED
SERVICE PERSONNEL.

Radio Frequency Power Supply Features

Seren IPS Inc. Radio Frequency (RF) RF Power Supplies are intended for use with radio frequency plasma processing systems and radio frequency processing applications.

The RX01 and LX01-Series RF Power Supplies provide a level-controlled radio frequency power output. Available frequencies are 350-460KHz (LX01 Series), 1.7-2.1MHz, 13.56MHz, 27.12MHz, and 40.68MHz (RX01-Series) at power levels up to 15000 Watts. The RX01 and LX01-Series RF Power Supplies feature operator-accessible controls, a visual display of power supply status, and control interfaces to the user's processing system. Other RF Power Supply features are listed below:

- Packages: R/L101, R/L301, R/L101MKII, R/L301MKII: ½ Rack, 3U High Package
R/L601, R/L1001: ½ Rack, 4U High Package
R/L2001, R/L3001: 19" Rack, 4U High Package
R4001: 19" Rack, 4U High Package
R5001: 19" Rack, 4U or 5U High Packages
L5001: 19" Rack, 5U High Package
R10001, R15001: 19" Rack, 6U High Package
- Flexible AC Mains operating voltage range:
R101, R/L301: 90-140VAC or 180-264VAC, selectable via transformer taps
R/L101MKII: 90-264VAC, universal input, no taps to configure.
R/L301MKII: 90-264VAC, universal input, no taps to configure.
R/L601: 105-264VAC, universal input, no transformer taps to configure
R/L1001: 190-264VAC, no transformer taps to configure.
R/L2001, R/L3001, R4001, R5001, L5001:
190-264VAC or 380-415VAC, no transformer taps to configure
(refer to Technical Data section for unit-specific details).
R10001, R15001:
180-264VAC or 380-415VAC, no transformer taps to configure
(refer to Technical Data section for unit-specific details).
- User-programmable 350KHz to 460KHz synthesized internal frequency source (L-Series)
(other frequency ranges available from 100KHz to 460KHz – consult factory)
- User-programmable 1.7MHz to 2.1MHz synthesized internal frequency source (R-Series)
- Crystal-Controlled fixed frequency (R-Series)
- Programmable Variable Frequency Tuning. (1.7-2.1MHz R-Series, L-Series Models)
- Bright, easy to read 4 Line Vacuum Fluorescent Display, capable of displaying Forward and Reflected RF Power, Control Mode, Power Supply status, and RF or DC Probe Voltage.
- Front panel controls for RF On/Off, mode selection, and programming
- Front Panel, Analog, and Serial control interfaces
- Forward Power and Load (Net) Power Leveling
- Scaleable Forward and Reflected power metering
- Scalable RF and DC Probe Voltage display
- Remote control operation via analog system interface connector
- Computer Control via RS-232/422/485 serial interface. Other optional interfaces available.
- Common Exciter input and output
- Air Cooling (100-1000 Watt models)
- Water Cooling (models over 1000 Watts)

Installation:

Recommended mounting:

Seren IPS Inc. RF Power Supplies are designed for placement on a shelf within an equipment rack, in a clean environment. Environment type: Pollution Degree 2. The shelf within the equipment rack must be capable of supporting the full weight of the unit.



Seren IPS R/LX01-Series RF Power Supplies are designed for operation in a clean environment (Pollution Degree 2 or cleaner). Operation in dirty/dusty/harsh environments (Pollution Degree 3 or greater) may result in damage to the RF Power Supply's internal components and is not covered under warranty.

The RF Power Supply is supplied with Rack Mounting Ears. The mounting ears are designed for securing the RF Power Supply to the equipment rack rail. The rack mounting ears ***are not*** designed to support the weight of the RF Power Supply. The user must provide a shelf within the equipment rack to support the weight of RF Power Supply. The user is responsible for providing mounting hardware. RF Power Supply weights are listed by model type in the technical specifications section of this manual.

Note: For **SEMI S8 Compliance**, the RF power supply must be mounted with the centerline of the front panel display located between 0.0 inches (0.0 cm) and 64.0 inches (162.6 cm) above the floor.

Mounting Options for ½ -Rack RF Power supplies:

One (1) ½-rack RF Power Supply may be mounted in a 19" equipment rack with the use of an optional single rack mount kit. The user must provide a shelf within the equipment rack to support the weight of unit.

Two (2) ½-rack RF Power Supplies may be mounted in a 19" equipment rack with the use of an optional dual rack mount kit. The user must provide a shelf within the equipment rack to support the weight of two (2) ½-rack units.

Supplied Accessories:

Supplied accessories vary by model type. Supplied accessories may include power cords, rack ears, water valves, and other accessory items. Refer to the appropriate RF Power Supply model's page in the technical specifications section of this manual.

Ventilation:

All of the RX01/LX01 series RF Power Supplies require ventilation, including the water-cooled model types. The forced-air cooling requirements vary by model type. Refer to the appropriate RF Power Supply model's page in the technical specifications section of this manual for the model-specific forced air cooling requirements. If the unit is mounted in an equipment rack or other suitable enclosure, ensure there is adequate fresh (cool) air intake and an exhaust path for the rear panel fan.



Placing the RF Power Supply in an unventilated or sealed enclosure will create an "oven" effect and force the unit to shut down. Continued operation under conditions of poor ventilation may degrade or damage the RF Power Supply. Maximum air intake temperature is +40°C

Connection To A Water Cooling System: (*Water-cooled RF Power Supplies only*)

Water-cooled RF Power Supplies requires connection to an external, user-supplied water chiller or water re-circulation system. Two (2) 3/8" N.P.T. female ports are provided on the rear panel of the unit. An external solenoid water valve is provided to prevent condensation within the RF Power Supply.

Connecting to Water Inlet/Outlet Ports:

Water-cooled RF Power Supplies use 3/8" N.P.T. (tapered), dry-seal, hexagonal female fittings for coolant water inlet and outlet port connections. Although the coolant water ports are brazed to an internal bracket or heatsink, the coolant water ports can be damaged by excessive torque when threading a fitting into the coolant water inlet and outlet ports.

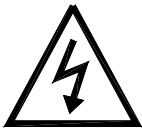

Improper installation, removal, or over-tightening of water fittings will damage the water inlet/outlet ports and cause water leaks. The water leak may be internal and unobserved.

Damage to the water inlet/outlet ports and internal components resulting from improper fitting installation or removal are not covered by Seren IPS Inc. product warranty.

WARNING!

Improper coolant water fitting installation or removal may cause water leaks and create an electrocution hazard.

Use the methods specified below to install or remove coolant water fittings.

Water Fitting Installation Method	
Step	Action
1.	Wrap a layer of Teflon pipe sealant tape around the male threads of the fitting to be installed in the water inlet or outlet port.
2.	Thread the fitting into the water inlet or outlet port <i>by hand</i> until tight.
3.	Place a wrench on the hexagonal coolant water port. Hold the wrench steady to prevent rotation of the coolant water port.
4.	Place a second wrench on the water fitting threaded into the coolant water port in step 2.
5.	Turn the water fitting with the second wrench one-quarter (1/4) to one-half (1/2) turn clockwise to seat the fitting and create a dry seal.
6.	Apply coolant water and ensure there are no leaks at the coolant water inlet or outlet port threads.

Water Fitting Removal Method	
Step	Action
1.	Disable coolant water flow and drain the system or system segment pertaining to the RF Power Supply. Drain the supply lines connected to the RF Power Supply.
2.	Place a wrench on the hexagonal coolant water port. Hold the wrench steady to prevent rotation of the coolant water port
3.	Place a second wrench on the water fitting to be removed from the coolant water port.
4.	Turn the water fitting with the second wrench one-quarter (1/4) to one-half (1/2) turn counter-clockwise to un-seat the fitting.
5.	Unthread the fitting from the coolant water inlet or outlet port <i>by hand.</i>

Coolant Water Temperature and Flow Rate:

Coolant water inlet temperature range is +15°C to +40°C. Recommended coolant water inlet temperature range is +22°C to +28°C (to prevent condensation). Minimum coolant water flow rate varies by model type. Refer to the appropriate RF Power Supply model's page in the technical specifications section of this manual for the model-specific coolant water flow rate. Detailed coolant water specifications are located in the Technical Specifications section of this manual.

To prevent condensation within the RF Power Supply, a solenoid water valve is provided.

Coolant Water Supply Lines:

To ensure sufficient coolant water flow, the coolant water supply and return lines must have an inside diameter (I.D.) of 3/8 inch [9.52mm] or greater. Connect the water supply lines directly to the system water supply manifold.



DO NOT connect the RF Power Supply's coolant lines in series or "daisy-chain" with other water-cooled equipment. Other water-cooled equipment may have restricted water paths, resulting in insufficient water flow through the RF Power Supply.

The RF Power Supply's solenoid water valve disables the water flow through the unit when the RF output is "off" or when the AC Mains is "off". Interrupting coolant water flow to other water-cooled equipment may cause damage to that equipment.

Solenoid Water Valve Installation:

The solenoid water valve *must* be connected to the unit before connecting to the water re-circulation system and enabling AC Mains power. To prevent condensation inside the RF Power Supply, the solenoid water valve disables water flow when the RF output is “off” or when the unit’s AC Mains power is disabled.



Failure to install the solenoid water valve could allow condensation to build up within the RF Power Supply and may result in internal damage or a fire.

Note: Install or remove the solenoid water valve in accordance with the water fitting installation or removal methods outlined above.

Step	Action
1.	Thread the pipe nipple on the “OUT” port of the solenoid valve into the “WATER IN” port on the rear panel.
2.	Connect the coolant water “supply” line to the “IN” port on the solenoid valve. Use a wrench on the hex nipple between the water valve and the “WATER IN” port to prevent over-tightening of the nipple into the “WATER IN” port.
3.	Connect the coolant water “return” line to the “WATER OUT” port on the rear panel.
4.	Plug the water valve’s connector into the rear panel “VALVE” connector.

RF Output Connection:

Connect the RF Power Supply’s RF output to a suitable load via a 50-Ohm coaxial cable.



CAUTION: Do not enable mains power or operate the RF Power Supply without connecting a suitable load to the RF Output connector. Operating without a suitable load may damage the RF Power Supply and void the warranty.



WARNING: Do not enable mains power or operate the RF Power Supply without connecting a suitable load to the RF Output connector. Operating without a suitable load connected to the RF Output connector may create a Shock, Electrocution, or RF Energy Burn Hazard

The power level, frequency of operation, load configuration, length of the cable run, and other factors determine the type of coaxial cable appropriate for a particular application. A technical discussion of these factors and the coaxial cable selection process is outside the scope of this manual. Consult with the Seren IPS Inc. sales department, customer service department, or a Seren IPS Inc. representative to select the coaxial cable appropriate for your RF power supply and application.

Attaching the RF Output Cable

Power levels of 10,000 watts or less:

Seren IPS RF power supplies with rated output power levels of 10,000 Watts or less are equipped with a variety of screw-on coaxial RF output connectors. Connector types include “N”, “HN”, “7/16 DIN”, and “LC”. Not all connector types are available on all models – RF output connector type is a function of output power. Consult the specifications for the RF power supply in the Technical Data section for the model-specific RF output connector type.

1. Align the RF output cable's connector pin over the center socket of the RF output connector.
2. Gently push the RF output cable connector onto the body of the RF power supply's RF output connector. Keep the RF output cable perpendicular to the rear panel of the RF power supply.
3. Thread the shell of the RF output cable's connector onto the body of the RF power supply's RF output connector. Ensure the outer shell of the RF output cable connector is completely threaded onto the RF output connector.



CAUTION: The outer shell of the RF output cable connector provides the ground (earth) return path for the RF output power. If the connector shell is not fully tightened, the RF power supply may experience high reflected power conditions or other performance issues.



WARNING: The outer shell of the RF output cable connector provides the ground (earth) return path for the RF output power. If the RF output cable connector is not fully tightened onto the RF output connector, a potential Shock, Electrocution, or RF Energy Burn Hazard may be created.

Power levels over 10,000 Watts

Seren IPS RF power supplies with rated output power levels over 10,000 watts are equipped with a 1-5/8" EIA Flange (bolt-on) connector.

1. Remove the four (4) hex nuts and lock washers from the 5/16-18 studs on the RF power supply's RF output connector and set them aside. The hex nuts and lock washers will be re-installed after the connector has been mated to a RF output cable.
2. Examine the RF output cable's 1-5/8" EIA flange connector. If the flange connector is equipped with a “bullet” center pin installed, remove it from the connector by pulling on the bullet pin. Set the bullet pin aside (the RF Power Supply's output connector is supplied with a bullet pin).

3. Align the RF output cable flange connector's center socket with the Bullet pin on the RF power supply's RF output connector. Align the index pin on the RF cable's flange connector with the index hole on the RF power supply's RF output connector.
4. Carefully push the RF output cable's center socket onto the RF output connector's bullet pin. Keep the RF output cable perpendicular to the rear panel of the RF power supply. Do not "wobble" the RF output cable side-to-side or up-and-down. "Wobbling" the RF output cable may damage the RF power supply's RF output connector.
5. Push the RF output cable's flange connector fully onto the RF power supply's RF output connector. The face of the RF output cable's connector flange must touch the face of the RF output connector. The 4 studs from the RF output connector will pass through the 4 holes on the RF output cable's connector flange.
6. Install the four 5/16-18 hex nuts and lock washers removed from the RF output connector in step number 1. Torque the hex nuts to 109-111 inch-pounds (12.31 – 12.54 newton-meters).



CAUTION: The flange of the RF output cable connector provides the ground (earth) return path for the RF output power. If the output cable flange is not fully secured onto the RF output connector, the RF power supply may experience high reflected power conditions or other performance issues.

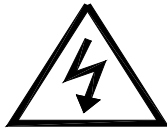

WARNING: The flange of the RF output cable connector provides the ground (earth) return path for the RF output power. If the output cable flange is not fully secured onto the RF output connector, a potential Shock, Electrocution, or RF Energy Burn Hazard may be created.

Connection to AC Mains:

BEFORE connecting the RF Power Supply the AC mains, verify the AC Mains voltage marked on the ratings plate, located on the top or side panel of the RF Power Supply, is compatible with your AC Mains voltage. If the AC Mains voltage on the ratings plate is not compatible with your AC Mains voltage, contact a Seren IPS Inc. service depot for assistance.

Note: For SEMI S2 compliance, the system power distribution panel, system integrator, or end-user must supply an external over-current protection/disconnect device (fuse or circuit breaker) with a minimum interrupting capacity of 10,000A (10,000AIC)



CAUTION: CHECK YOUR MAINS VOLTAGE AND THE MAINS VOLTAGE SPECIFIED ON THE RATINGS PLATE OR CONSULT A QUALIFIED ELECTRICIAN BEFORE CONNECTING THE RF POWER SUPPLY TO MAINS POWER. CONNECTING THE RF POWER SUPPLY TO THE WRONG MAINS VOLTAGE MAY DAMAGE THE RF POWER SUPPLY AND VOID THE WARRANTY.

Note: Power cords and power plugs vary by model type and configuration. Power cord and power plug information for each model is listed in the Technical Data section of this manual.

Note: For units with 3-phase AC mains, phase rotation is not important/not critical.

Note: Units configured for 380-415V 3-Phase 5-Wire Wye AC Mains are supplied with power cords but are not supplied with power plugs. Seren IPS equipment configured for 3-Phase Wye AC mains requires the neutral conductor to be connected. The installer is responsible for making power connections per applicable local and national codes – consult a qualified electrician.

AC Mains Connection Procedure:

AC Mains Connection Procedure - Models with detachable power cords:	
Step	Action
1	Ensure a suitable load is connected to the rear panel RF OUTPUT connector
2	Water-cooled units only: Ensure the unit is properly connected to a source of coolant water / water re-circulation system and that coolant flow is available.

AC Mains Connection Procedure - Models with detachable power cords:	
Step	Action
3	Ensure the front panel power switch is in the "OFF" (0) position
4	Ensure the rear panel circuit breaker is in the "OFF" (0) position
5	Ensure the AC Mains Power source is disabled/locked out/tagged out
6	Plug the power cord into the power inlet on the rear panel of the RF power supply
7	Plug the power cord into the AC Mains power outlet
8	Enable the AC Mains power source.

AC Mains Connection Procedure - Models with captive power cords:	
Step	Action
1	Ensure a suitable load is connected to the rear panel RF OUTPUT connector
2	Water-cooled units only: Ensure the unit is properly connected to a source of coolant water / water re-circulation system and that coolant flow is available.
3	Ensure the front panel power switch is in the "OFF" (0) position
4	Ensure the rear panel circuit breaker is in the "OFF" (0) position
5	Ensure the AC Mains Power source is disabled/locked out/tagged out
6a	For RF Power Supplies equipped with a power plug: Connect the R/LX01-Series RF power supply's power plug to the AC Mains power source.
6b	For RF Power Supplies not equipped with a power plug or not equipped with a power cord and power plug: Consult a qualified electrician to: Install a suitably rated power plug on the RF power supply's power cord and connect to the AC Mains power source. -OR- Hard-wire the R/LX01-Series RF power supply's power cord to a suitable disconnect device in accordance with local and national electric codes. -OR- Models R10001 & R15001: Hard-wire the R/LX01-Series RF power supply's AC Mains terminal block to a suitable disconnect device in accordance with local and national electric codes. Refer to wiring details on the next page.
8	Enable the AC Mains power source.

Wiring Details for Units Supplied Without a Power Plug:

Depending on model, AC mains configuration and/or OEM configuration requirements, some R/LX01-Series RF Power Supplies are equipped with a power cord that does not have a power plug. Refer to the Technical Data section for model-specific details regarding available AC mains configuration options.

Detailed information on connecting un-terminated power cord wires to AC Mains power is listed below, by AC Mains voltage type. Depending on the model, date of manufacture, and destination country, the RF power supply's power cord may be configured with either North American or International Harmonized color-coded conductors. Both color codes are described in this manual.

Note: For units with 3-phase AC mains, phase rotation is not important/not critical.

Note: Seren IPS equipment configured for 380-415V 3-Phase 5-Wire Wye AC mains requires the neutral conductor to be connected.



CAUTION:

**RISK OF ELECTRIC SHOCK, ELECTROCUTION
AND/OR DEATH**

**Disable and lock-out AC Mains power at source
before making AC Mains power connections.**

**If you are unsure of the AC Mains power type available,
unsure about the R/LX01-Series RF Power Supply's AC
Mains power requirements or configuration, or are unsure
about making connections to AC Mains power, **STOP** here
and consult a qualified electrician.**

AC Mains Connection Procedure:

1. Disable AC Mains power at the power source and lock-out/tag-out.
2. Connect power cord to power source per the diagrams below:

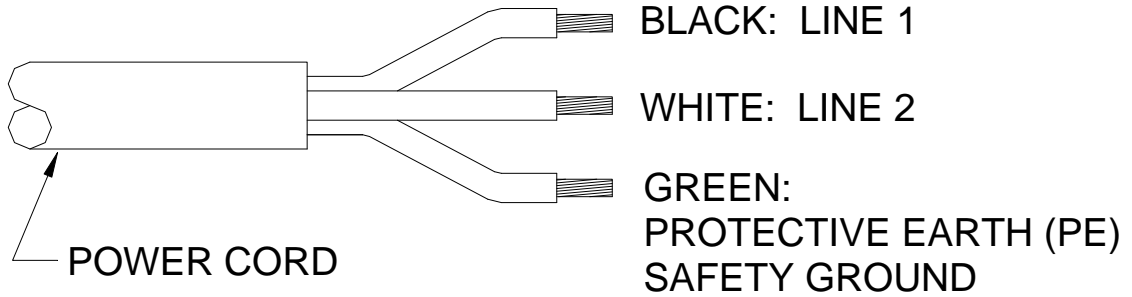

200-240VAC Single Phase, 3-Wire, North American Color Code

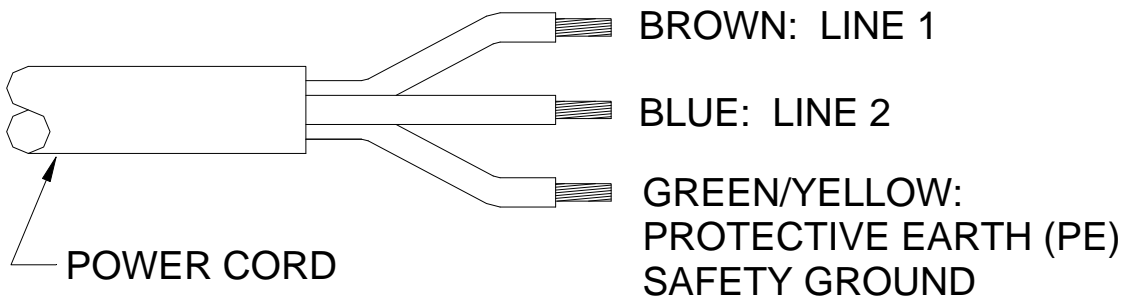

200-240VAC Single Phase, 3-Wire, International Harmonized Color Code

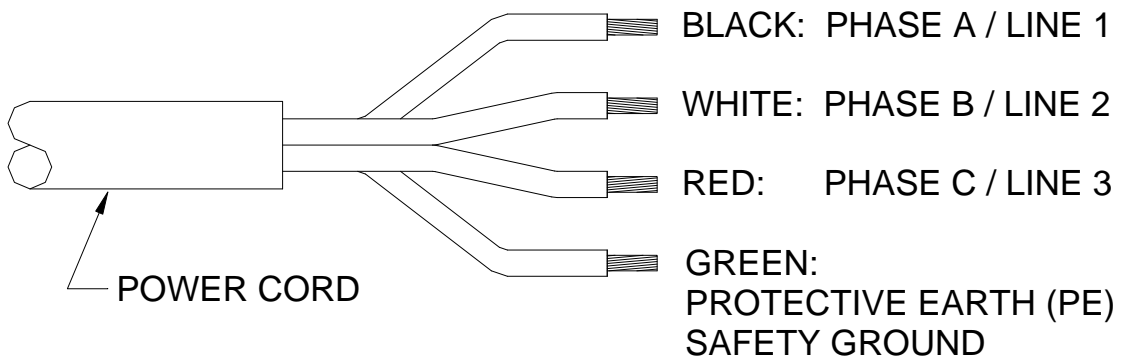

200-240VAC 3-Phase, 4-Wire Delta , North American Color Code

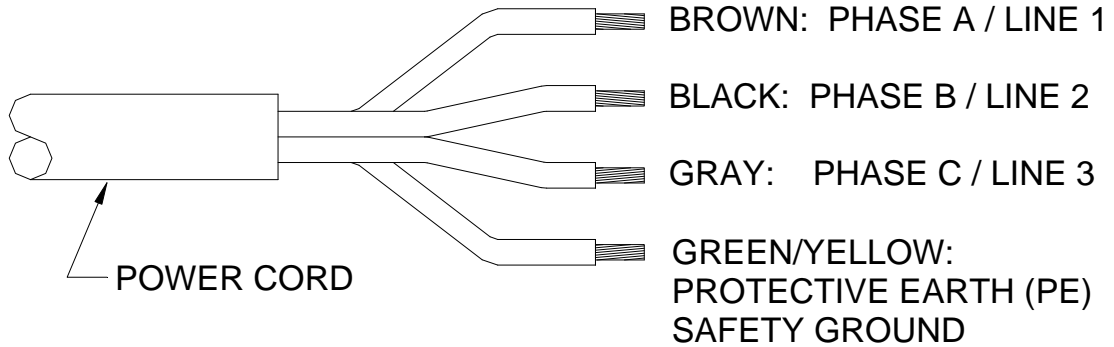

200-240VAC 3-Phase, 4-Wire Delta , International Harmonized Color Code

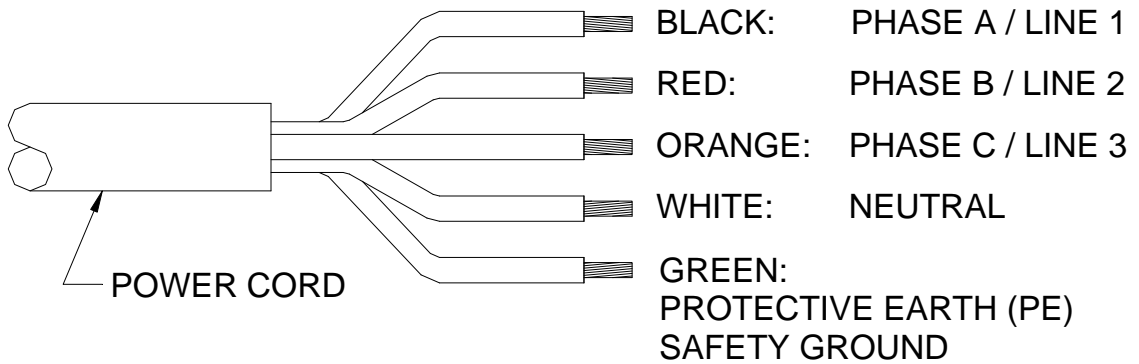

380-415VAC 3-Phase, 5-Wire Wye , North American Color Code

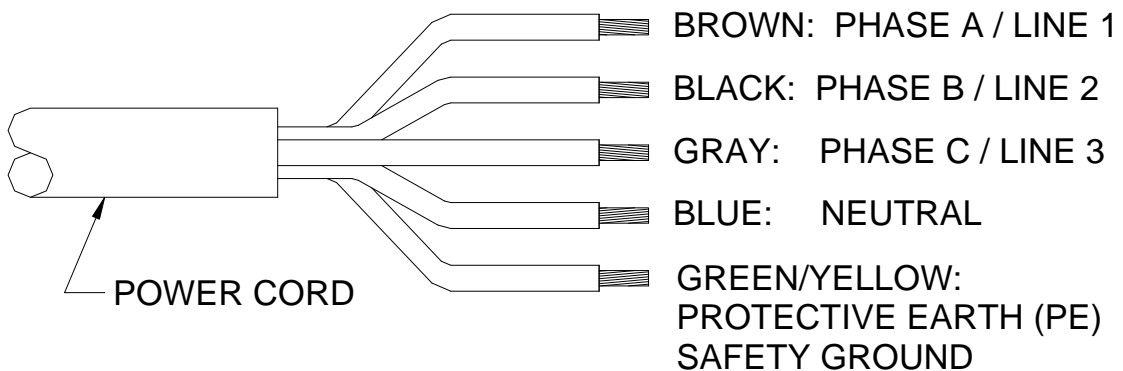

380-415VAC 3-Phase, 5-Wire Wye , International Harmonized Color Code

Wiring Details for Units Supplied Without A Power Plug:

Models R10001, R15001 supplied without power cords

Standard configurations of RF Power Supply models R10001 and R15001 are equipped with a power cord that does not have a power plug. OEM configurations may be supplied without power cord and without power plugs. Model R10001 and R15001 RF Power supplies are equipped with an enclosed AC Mains terminal block on the rear panel. For units supplied without a power cord, the user or system integrator is responsible for providing AC Mains power wiring to the rear panel AC Mains terminal block in accordance with national and local electrical codes.

Refer to the Technical Data section for model-specific details regarding available AC mains configuration options and requirements.

Detailed information on connecting the AC Mains terminal block to AC Mains power is listed below, by AC Mains voltage type.

Phase rotation is not important/not critical.

Minimum recommended wire size (all conductors including ground/protective earth): 6 AWG (16mm²).

Terminal Block Torque: 35.5-39.5 Lb-In (4.0-4.5 N-m)



CAUTION:

**RISK OF ELECTRIC SHOCK, ELECTROCUTION
AND/OR DEATH**

Disable and lock-out AC Mains power at source before making AC Mains power connections.

If you are unsure of the AC Mains power type available, unsure about the HR-Series RF Power Supply's AC Mains power requirements or configuration, or are unsure about making connections to AC Mains power, STOP here and consult a qualified electrician.

AC Mains Connection Procedure - Models R10001, R15001 without power cords:

1. Disable AC Mains power at the power source and lock-out/tag-out.
2. Remove the AC Mains terminal block cover. Remove the twelve (12) cover screws indicated in the figure below. Remove the "L"- shaped terminal block cover and set aside.

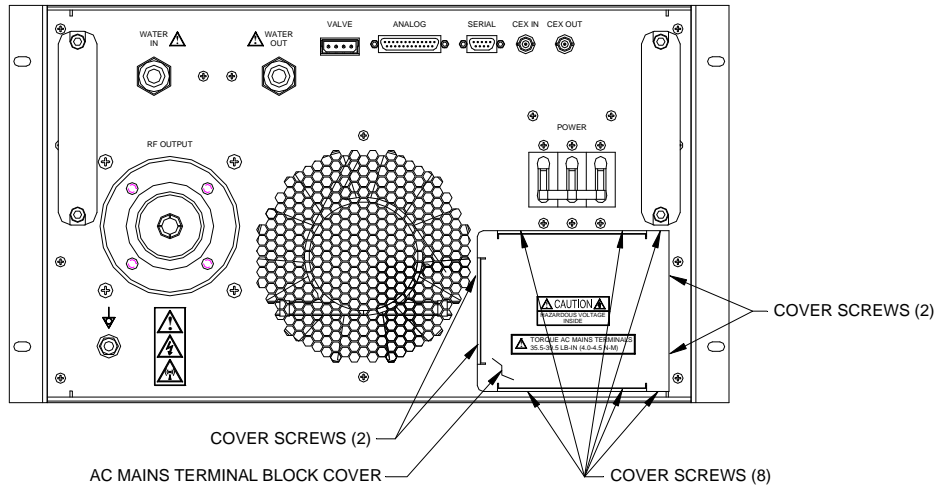

Rear Panel Terminal Block Enclosure Cover Screw Locations

(Model R15001 Shown, locations are the same for Model R10001)

3. Install a cord grip or flexible conduit fitting (user-supplied), as appropriate to the installation.

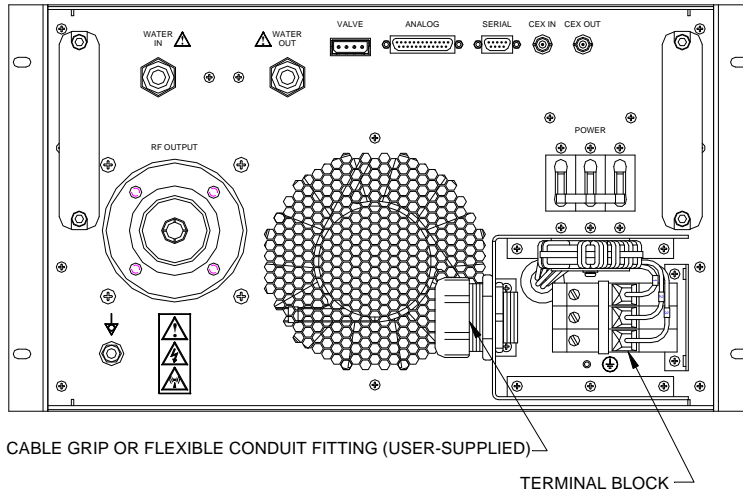

Rear Panel Terminal Block Enclosure, Cable Grip Installation

(Model R15001 Shown, details are the same for Model R10001)

4a. Connect AC Mains - 200-240V 3-Phase 4-Wire Delta

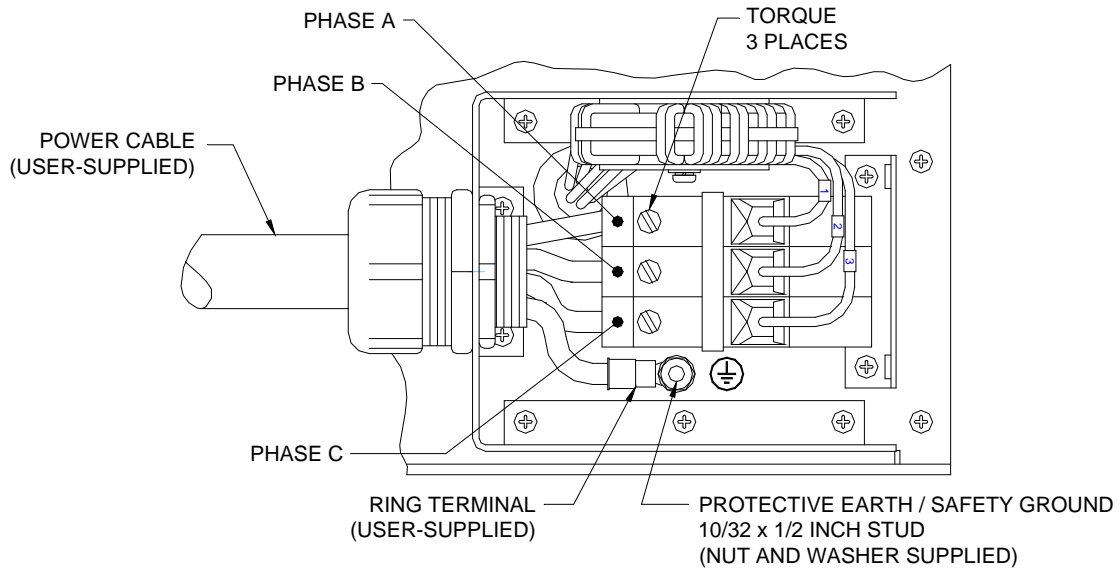

Rear Panel Terminal Block Connections, 200-240V 3-Phase 4-Wire Delta
(Connections are the same for Models R10001 and R15001)

Notes:

- Use **COPPER** wire only.
- Minimum recommended wire size for all phases and protective earth/safety ground: 6AWG (16mm²). Use larger diameter/gauge wire for longer runs.
- AC Mains terminals are box-clamp type. Terminals accept stranded or solid copper wire, 10 AWG (10mm²) to 2 AWG (25mm²). Strip Length: 0.75 inch (19mm)
- Stranded wire is recommended for ease of installation.
- Use of ferrules without plastic sleeves on stranded wire is recommended for ease of installation, but is not required.
- Insert wire into terminal block opening, then torque terminal block set-screw to 35.5-39.5 Lb-In (4.0-4.5 N-m).
- Connect protective earth/safety ground to 10/32 x 1/2 inch stud with supplied nut and washer.



Use only COPPER wire for AC Mains connection.
Using Aluminum wire may cause overheating and/or a fire hazard.



Torque AC Mains terminals to 35.5-39.5 Lb-In (4.0-4.5 N-m).
Failure to properly torque AC Mains terminals may cause overheating and/or a fire hazard.

4b. Connect AC Mains - 380-415V 3-Phase 5-Wire Wye

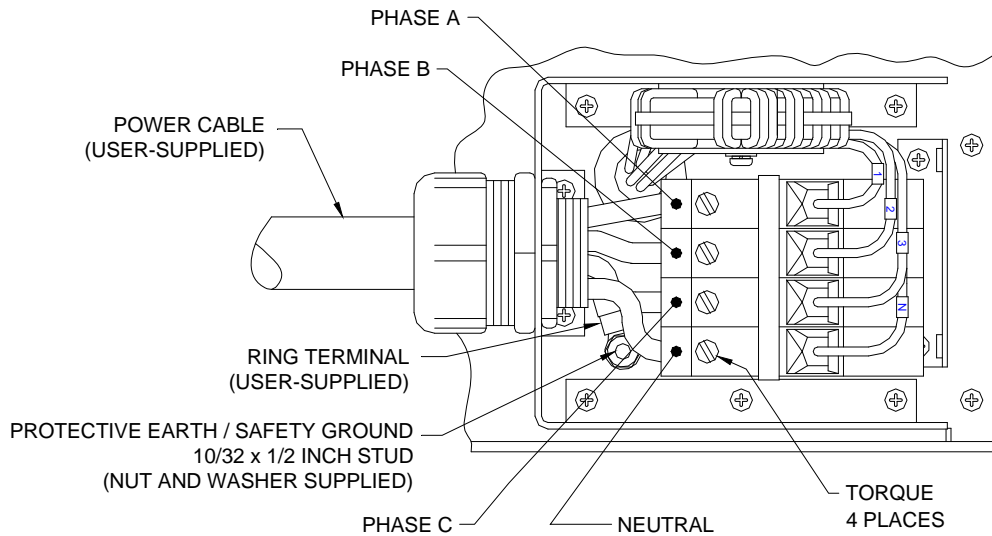

Rear Panel Terminal Block Connections, 380-415V 3-Phase 5-Wire Wye
(Connections are the same for Models R10001 and R15001)

Notes:

- Use **COPPER** wire only.
- Minimum recommended wire size for all phases, neutral, and protective earth/safety ground: 6AWG (16mm²). Use larger diameter/gauge wire for longer runs.
- AC Mains terminals are box-clamp type. Terminals accept stranded or solid copper wire, 10 AWG (10mm²) to 2 AWG (25mm²). Strip Length: 0.75 inch (19mm)
- Stranded wire is recommended for ease of installation.
- Use of ferrules without plastic sleeves on stranded wire is recommended for ease of installation, but is not required.
- Insert wires into terminal block openings, then torque terminal block set-screws to 35.5-39.5 Lb-In (4.0-4.5 N-m).
- Connect protective earth/safety ground to 10/32 x 1/2 inch stud with supplied nut and washer.



Use only COPPER wire for AC Mains connection.
Using Aluminum wire may cause overheating and/or a fire hazard.



Torque AC Mains terminals to 35.5-39.5 Lb-In (4.0-4.5 N-m).
Failure to properly torque AC Mains terminals may cause overheating and/or a fire hazard.

5. Re-install terminal block enclosure cover.

End of Procedure.

Emergency Off (EMO):

R/LX01-Series RF power supplies are embedded devices and are not equipped with an Emergency Off (EMO) device. It is recommended the RLX01-Series RF power supply be connected to an external, user-supplied, AC Mains power distribution panel that provides EMO function by disabling the AC Mains power to the RLX01-Series RF power supply.

Disabling AC mains power under an emergency (EMO) condition will not adversely affect the RLX01-Series RF power supply – the RF output will shut off and remote communications will cease. Any unsaved user settings will be lost.

When AC mains power is restored, the R/LX01-series RF power supply will power-up, but will not deliver RF output power. For safety reasons, the RF output must be re-enabled by remote communication or an operator (via the front panel controls).

Note: R/LX01-Series RF power supplies are equipped with an external interlock signal function on the rear panel Analog Interface connector. This is not an EMO connection/function.

The Analog Interface connector external interlock function must be satisfied in order to enable RF output. If the external interlock is tripped while the RF output is “on”, AC mains power remains on and the RF output is disabled.

When the external interlock is reset, the RF output will not be automatically re-enabled. A remote communication or operator intervention (via the front panel controls) is required to re-enable the RF output.

Analog Interface connector signals are discussed in detail in the Rear Panel Controls and Connections section of this manual.

System Interfacing:

The RF Power Supply can be used “stand-alone” or can be interfaced with a processing system. There are connectors on the rear panel dedicated to system interfacing. Refer to the Rear Panel Controls and Connections section for detailed pin lists and signal descriptions. There are many possible interface schemes – a full discussion of interface schemes is beyond the scope of this document. Contact the Seren IPS Inc. customer service department if you require assistance with interface connections. A brief summary of the connectors is listed below.

“Analog Control” Connector

Provides status and control signals for an external system controller to operate the RF Power Supply. Because of different features available on different models, the Analog Control connector pin-list is slightly different on some models. Refer to the Rear Panel Controls and Connections section for interface details.



The analog interface's EXTERNAL INTERLOCK circuit *must* be completed or the RF Power Supply's output will not turn on. Refer to Rear Panel Controls and Connections for details.

“Serial Interface” Connector

Serial communications port for computer control via RS-232, RS-422, or RS-485 protocols.

“CEX IN” Connector

Radio Frequency signal input. The RF Power Supply uses the signal present at this connector as the frequency source when the RF Power Supply is configured for “slave” operation in a multiple RF power supply system. The CEX IN signal must be the same frequency (or frequency range) as the RF Power Supply's internal frequency source.

“CEX OUT” Connector

Radio Frequency signal output. The signal present at this connector is the same frequency the RF Power Supply is using to produce its RF output. This signal can be used as a frequency signal source for other RF Power supplies in a multiple RF power supply system.

“DCP” Connector (optional, 100 Watt and 300 Watt models only)

Voltage Probe Inverter input. This optional circuit inverts the output of a passive DC Voltage Probe when using external feedback for power regulation (voltage control). When installed, a 0 to –10VDC signal applied to this connector produces a 0 to +10VDC output that is routed to the Analog Interface connector's FEEDBACK signal. Refer to the Analog Interface Connector and Typical Interface Connections sections for details.

Front Panel Controls and Display:

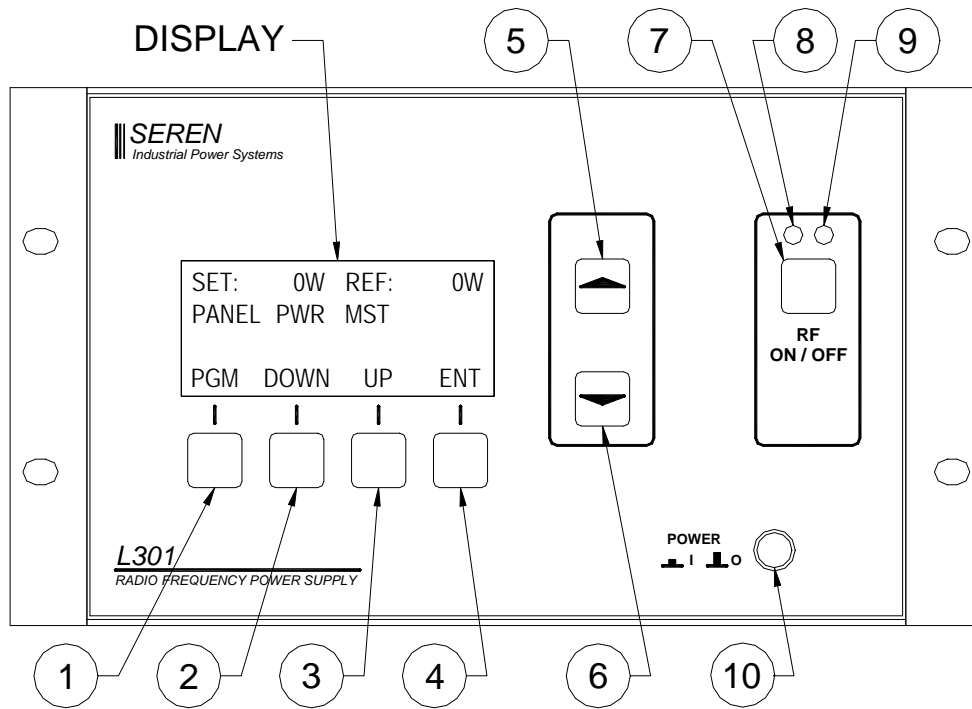

Buttons (Model L301MKII Shown, functions are the same for all RX01/LX01 series models)

Item	Name	Description
1	Program/Run	Toggles the RF Power Supply between the RUN mode and PROGRAM mode. In Program mode, display line 3 changes to show Programmable Menu Entry Options. The button legend changes from “PGM” to “RUN” when in the Program mode.
2	Down	Moves down the programming menu
3	Up	Moves up the programming menu
4	Enter	Programs (saves) changes made to a parameter
5	Value Up	Changes Parameter Value - Increment
6	Value Down	Changes Parameter Value - Decrement
7	RF ON/OFF	Enables/Disables the RF output in “local” mode, disables the RF output in any operational mode.
8	RF ON Indicator Lamp	Glows RED when the RF Output is enabled (on).
9	RF OFF Indicator Lamp	Glows BLUE when the RF output is disabled (off)
10	Power	AC Mains power enable/disable. Note: Power button may be omitted on OEM-specific configurations

Display

The front panel display shows the operational status of the RF Power Supply and provides legends for the keypad.

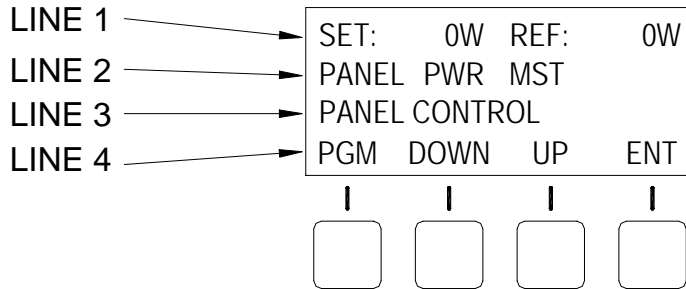

Line	Description
1	<p>Power Display Line</p> <p>Displays power setpoint and reflected power when the RF Output is disabled. Displays forward power (or load power) and reflected power when the RF output is enabled</p>
2	<p>Status Display Line</p> <p>Displays the current control source, power control mode, exciter mode and operational alarms. Operational alarms are displayed on the extreme right side of the line (see the problem solving section for alarm details).</p> <p>[CONTROL SOURCE] [POWER CONTROL MODE] [EXCITER MODE] [ALARM]</p> <p>Control Source: Panel = Front Panel Control Analog = Analog Interface Serial = Serial Interface</p> <p>Power Control Mode: PWR = Forward Power Leveling (internal power sensor) PLS = Pulsing Enabled (internal power sensor) VLT = Voltage Control (external feedback)</p> <p>Exciter Mode: MST = Master (internal frequency source) SLV = Slave (external frequency source)</p>
3	<p>User Configuration Display Line</p> <p>In RUN mode: Blank</p> <p>In PROGRAM mode: Displays a programmable parameter and its current setting.</p>
4	<p>Keypad Menu – button legends change depending on mode</p>

Operation

Front panel operation of the RF Power Supply is simple. This section describes the use and operation of the front panel controls in a “how to...” manner. Refer to the front panel illustration on the previous page for item references.



Connect the RF Power Supply's RF output to a 50-Ohm resistive load, Impedance Matching network, processing system or other suitable load capable of handling the unit's full rated power output *before* enabling AC mains Power.

Front Panel Operation

Mains Power On/Off:

Press the POWER button (item 10) to enable mains power – the front panel display will illuminate and momentarily display the startup message. Press the POWER button again to disable mains power.

Control Source:

The control source is the control interface for the RF Power Supply. The RF Power Supply has three (3) user-selectable control sources.

- The “PANEL” control source is for front panel operation of the RF Power Supply.
- The “ANALOG” control source is for controlling the RF Power Supply from the user's system, via the rear panel ANALOG INTERFACE connector.
- The “SERIAL” control source is used for controlling the RF Power Supply from a computer or system controller, via an RS-232, RS-422, or RS-485 interface.

To select a control source, follow the directions below:

PANEL control:

To change the control source to the front panel,

1. Press the PGM button (Item 1) once (enter the programming menu).
2. Press the DOWN button (item 2) or the UP button (item 3) until line 3 of the display shows the current control source (PANEL CONTROL, ANALOG CONTROL, or SERIAL CONTROL).
3. Press the VALUE DOWN button (item 6) until PANEL CONTROL is displayed on line 3.
4. Press the ENT button (item 5) to save the selection.
5. Press the RUN button (item 1) to exit the programming menu.

ANALOG control:

To change the control source to the Analog interface connector,

1. Press the PGM button (Item 1) once.

2. Press the DOWN button (item 2) or the UP button (item 3) until line 3 of the display shows the current control source (PANEL CONTROL, ANALOG CONTROL, or SERIAL CONTROL).
3. Press the VALUE UP button (item 5) or the VALUE DOWN button (item 6) until ANALOG CONTROL is displayed on line 3.
4. Press the ENT button (item 5) to save the selection.
5. Press the RUN button (item 1) to exit the programming menu.

SERIAL control:

To change the control source to the Serial interface connector,

1. Press the PGM button (Item 1) once.
2. Press the DOWN button (item 2) or the UP button (item 3) until line 3 of the display shows the current control source (PANEL CONTROL, ANALOG CONTROL, or SERIAL CONTROL).
3. Press the VALUE UP button (item 5) until SERIAL CONTROL is displayed on line 3.
4. Press the ENT button (item 5) to save the selection.
5. Press the RUN button (item 1) to exit the programming menu.

Note: Pressing the RUN button (item 1) exits the programming menu. If changes were made and the ENT button *was not* pressed, the changes will not be preserved after a power-off/power-on cycle.

Note: The control source and control mode selections are saved when the ENT button is pressed. The RF Power Supply will power-up in the same mode.

Output Regulation Mode:

The Output Regulation mode allows the user to select the method the RF Power Supply uses to regulate its output power. There are three (3) types of output regulation control:

- The “POWER” (PWR) regulation mode uses the RF Power Supply’s internal power sensor to regulate the RF output power. There are two types of RF power leveling available on the RF Power Supply:
 1. Forward (FWD) Power leveling: The forward output power is measured by the RF Power Supply’s internal power sensor and compared against the requested output power setpoint. The unit’s power amplifier increases or decreases its output to maintain the requested power setpoint. Reflected power is displayed and monitored for internal protection.
 2. Load Power Leveling (Net Power Leveling): The forward and reflected power is measured by the RF Power Supply’s internal power sensor. The reflected power signal is subtracted from the forward power signal and compared against the requested net power setpoint to be delivered to the load. The unit’s power amplifier output increases or decreases its output to maintain the net power

delivered to the load. Reflected power is displayed and monitored for internal protection.

- The “VOLTAGE” (VLT) regulation mode uses an external feedback voltage (derived from a Voltage Probe in the processing system’s matching network or processing chamber) to regulate the RF output. The external feedback voltage is applied the analog interface connector’s FEEDBACK signal.

In Voltage regulation mode, the RF Power Supply’s output is regulated in terms of voltage. The external feedback voltage is measured by the RF Power Supply and compared against the requested Voltage setpoint. The unit’s power amplifier increases or decreases its output to maintain the requested voltage at the external voltage probe source. Reflected power is displayed and monitored for internal protection.

- The “CURRENT” regulation mode is similar to the Voltage Control mode. Current control mode uses an external feedback voltage (derived from a Current Probe in the processing system’s matching network or processing chamber) to regulate the RF output.

In Current regulation mode, the RF Power Supply’s output is regulated in terms of current. The external feedback voltage is measured by the RF Power Supply, interpreted as a current, and compared against the requested current setpoint. The unit’s power amplifier increases or decreases its output to maintain the requested current at the external current probe source. Reflected power is displayed and monitored for internal protection.

Note: If an RF Power Supply is intended for use with Current output regulation mode, it should be ordered with a compatible matching network equipped with the correct current probe scaling for the desired current range.

To select the desired output regulation control mode, follow the directions below:

Power Control Regulation Mode, Forward (FWD) Power Leveling:

1. Press the “PGM” button (item 1).
2. Press the “DOWN” button (item 2) until line three of the display is “POWER CONTROL” or “VOLTAGE CONTROL”
3. Press the “VALUE UP” button (item 5) or “VALUE DOWN” (item 6) until line 3 of the display indicates the desired regulation mode, “POWER CONTROL”.
The text on the left side of display line 2 should change to “PANEL PWR”
4. Press the “ENT” button (item 4) to save the mode selection.
5. Press the “DOWN” button (item 2) until line three reads “FWD POWER LEVELING” or “LOAD POWER LEVELING”
6. Press the “VALUE UP” button (item 5) or “VALUE DOWN” (item 6) until line 3 of the display indicates the desired power leveling type, “FWD POWER LEVELING”.
7. Press the “ENT” button (item 4) to save the mode selection.
8. Press the “RUN” button (item 1) to exit the programming menu.

Power Control Regulation Mode, Load (LOAD) Power Leveling:

1. Press the “PGM” button (item 1).
2. Press the “DOWN” button (item 2) until line three of the display is “POWER CONTROL” or “VOLTAGE CONTROL”
3. Press the “VALUE UP” button (item 5) or “VALUE DOWN” (item 6) until line 3 of the display indicates the desired output regulation mode, “POWER CONTROL”.
The text on the left side of display line 2 should change to “PANEL PWR”
4. Press the “ENT” button (item 4) to save the mode selection.
5. Press the “DOWN” button (item 2) until line three reads “FWD POWER LEVELING” or “LOAD POWER LEVELING”
6. Press the “VALUE UP” button (item 5) or “VALUE DOWN” (item 6) until line 3 of the display indicates the desired power leveling type, “LOAD POWER LEVELING”.
7. Press the “ENT” button (item 4) to save the mode selection.
8. Press the “RUN” button (item 1) to exit the programming menu.

Voltage Control Regulation Mode (VLT) mode:

1. Press the “PGM” button (item 1).
2. Press the “DOWN” button (item 2) until line 3 of the display is “POWER CONTROL” or “VOLTAGE CONTROL”
3. Press the “VALUE UP” button (item 5) or “VALUE DOWN” (item 6) until line 3 of the display indicates the desired regulation mode, “VOLTAGE CONTROL”.
The text on the left side of display line 2 should change to “PANEL VLT”
4. Press the “ENT” button (item 4) to save the mode selection.
5. Press the “RUN” button (item 1) to exit the programming menu.

Current Control Regulation Mode:

1. Press the “PGM” button (item 1).
2. Press the “DOWN” button (item 2) until line 3 of the display is “POWER CONTROL” or “VOLTAGE CONTROL”
3. Press the “VALUE UP” button (item 5) or “VALUE DOWN” (item 6) until line 3 of the display indicates the desired output regulation mode, “CURRENT CNTRL 0-10A”.
The text on the left side of display line 2 should change to “PANEL CUR”
4. Press the “ENT” button (item 4) to save the mode selection.
5. Press the “RUN” button (item 1) to exit the programming menu.

Setting the Output Level

1. Ensure the RF Power Supply is in the “RUN” mode – the legend above the Program/Run button (item 1) is “PGM”.
2. Use the Value Up button (item 5) or Value Down button (item 6) to adjust the power setpoint (SET: XXXXXW on the front panel display) to the desired power level.

Note: When operating in Voltage Control or Current Control regulation modes, the same method is used to set the desired Voltage or Current setpoint. When in Voltage regulation mode, the setpoint readout (SET: XXXXV) and output (XXXXV) is displayed in Volts. When in Current regulation mode, the setpoint readout SET: XX.XXA) and output (XX.XXA) is displayed in Amperes.

Enable RF Output

1. Ensure the RF Power Supply's RF output is connected to an appropriate load and the external interlock (Analog Interface Connector, pin 2) is in the proper state.
2. Press the front panel RF ON/OFF button (item 7). The blue RF OFF lamp will extinguish (item 9) and the red RF ON lamp will illuminate.
3. The left side of line one on the display will change from "SET XXXXXW" to "FWD XXXXXW"

Disable RF Output

1. Press the front panel RF ON/OFF button (item 7). The red RF ON lamp should extinguish (item 9) and the blue RF OFF lamp will illuminate.
2. The left side of line one on the display will change from "FWD XXXXXW" to "SET XXXXXW"

Configuring Programmable Parameters

Navigating the Programming Menu

TO ENTER the programming mode, press the “PGM” button (Program/Run button – item 1) on the front panel. The legend above the button will change from “PGM” to “RUN”.

TO EXIT the programming mode, press the “RUN” button (Program/Run button – item 1) on the front panel. The legend above the button will change from “RUN” to “PGM”.

Pressing the “DOWN” button (item 2) moves down the programming menu levels.

Pressing the “UP” button (item 3) moves up the programming menu levels.

Pressing the “ENT” button (item 4) saves the programmable parameter selection.

Pressing either the “UP” or “DOWN” buttons selects the next programmable parameter but does not save the parameter selection in the RF Power Supply’s memory. If changes are made and the “ENT” button *is not* pressed, the changes will not be preserved after a power-off/power-on cycle

The saved programmable parameters are recalled upon power-on.

PROGRAMMABLE PARAMETER REFERENCE CHART:

Programmable parameters are listed below. Asterisk (*) indicates factory default setting.

Note: All programmable parameters shown. Not all of the programmable parameters are applicable to all R/LX01 Series models and are notated in the “Applies To” column and in the individual parameter detail descriptions.

Programmable parameters that do not apply to your RF Power Supply type or RF Power Supply configuration will not be displayed when scrolling the menu.

PROGRAMMABLE PARAMETER REFERENCE CHART			
PARAMETER	DISPLAY LINE 3	OPTION	Applies To
Operating Frequency	FREQ XXXXXKHZ	-	All
Maximum Frequency	MAX FREQ XXXXXKHZ	-	All
Minimum Frequency	MIN FREQ XXXXXKHZ	-	All
Control Source Note: Setting the control source to Serial Control allows scrolling and setting of serial protocol parameters	PANEL CONTROL ANALOG CONTROL SERIAL CONTROL	PANEL* ANALOG SERIAL	All

PROGRAMMABLE PARAMETER REFERENCE CHART			
PARAMETER	DISPLAY LINE 3	OPTION	Applies To
Communications Protocol	PROFIBUS DEVICENET MODBUS 2W RTU MODBUS 4W RTU RS485-2 RS485-4 RS422 RS232	PROFIBUS DEVICENET MODBUS 2W MODBUS 4W RS485-4 RS485-2 RS422 RS232*	All
Address ID Number	ADDRESS # XXX	Range depends on selected protocol	All
Data Rate DeviceNet Protocol: 500, 250, 125 KBPS RS232, RS422, RS485, Modbus Protocols: 115200, 57600, 38400, 19200, 9600 4800, 2400 BAUD PROFIBUS Protocol: Data rate is detected automatically and set to match the PROFIBUS Master.	DATA RATE XXX KBPS XXXXXX BAUD	500 KBPS* 250 KBPS 125 KBPS 115200 BAUD 57600 BAUD 38400 BAUD 19200 BAUD * 9600 BAUD 4800 BAUD 2400 BAUD	All
Serial Communications ECHO (RS-232, RS-422, RS-485 Only)	ECHO: DISABLED	DISABLED* ENABLED	All
DeviceNet Assembly Set	DN Data XX out XX in	5 out 9 in* 52 out 70 in 30 out 36 in	DeviceNet Configured Units Only
Pulse Mode Note: Setting Pulse Mode to ENABLED allows scrolling and setting of pulse parameters	PULSE MODE ON PULSE MODE OFF	ON OFF*	See pulsing section
Pulse High Power Setpoint (Pulse Type 1 Only)	ENTER HI PWR 0W	0 Watts to Rated Power, Variable (Default: 0 Watts)	See pulsing section
Pulse Low Power (Pulse Type 1 Only)	ENTER LO PWR 0W	0 Watts to Rated Power, Variable (Default: 0 Watts)	See pulsing section
Pulse Frequency (Pulse Type 0 Only)	FREQUENCY XXXXX Hz	1Hz to 10,000Hz	See pulsing section

PROGRAMMABLE PARAMETER REFERENCE CHART			
PARAMETER	DISPLAY LINE 3	OPTION	Applies To
Pulse High Time (Pulse Type 1 Only)	HIGH TIME 5MS	1mS to 9999mS, Variable, (Default: 5mS)	See pulsing section
Pulse Duty Cycle	DUTY CYCLE 50 %	0% to 100%, (Default: 50%)	See pulsing section
Pulse Source	PULSE GATE INTERNAL PULSE GATE EXTERNAL	INTERNAL* EXTERNAL	All
Power Monitor Response	MONITOR OUTPUT PEAK MONITOR OUTPUT REAL	PEAK* REAL	L301
RF Output Ramping Note: Setting RF Output Ramping to ON allows scrolling and setting of ramping parameters	RAMP MODE OFF RAMP MODE ON	OFF* ON	All
RF Output Ramp-Up Time	RAMP ON TIME 1S	0S to 9999S, Variable (Default: 1S)	All
RF Output Ramp-Down Time	RAMP OFF TIME 1S	0S to 9999S, Variable (Default: 1S)	All
Output Regulation Mode Note: Setting Output Regulation to VOLTAGE CONTROL allows scrolling and setting of Probe Inversion parameters on R/L101MKII and R/L301MKII models	POWER CONTROL VOLTAGE CONTROL CURRENT CONTROL	Internal Power Sensor* External Feedback Voltage External Feedback Voltage	All
Voltage Limit	VOLTAGE LIMIT XXXX	1V to 1000V OFF*	All
Probe Inversion	VLT CNTRL +PRB DB25 VLT CNTRL -PRB BNC	Probe Inverter Disabled* Probe Inverter Enabled	R/L101MKII R/L301MKII Only
Analog Voltage Range Select	RANGE 5V F.S. RANGE 10V F.S.	5VDC* 10VDC	All
Power Leveling Select	FWD POWER LEVELING LOAD POWER LEVELING	Forward Power*, Load (Net) Power	All

PROGRAMMABLE PARAMETER REFERENCE CHART			
PARAMETER	DISPLAY LINE 3	OPTION	Applies To
Output Power Range Select	HIGH RANGE LOW RANGE	HIGH Range*, LOW Range	R/L101MKII, R/L301MKII, R/L601
Exciter Mode (Frequency Source) Select	EXCITER- MASTER EXCITER- SLAVE	Internal Source*, External CEX Input	All
Maximum Output Power	ENTER MAX POWER XXXXXW	1W to Rated Power (Default: Rated Power)	All
Source Menu Mode Note: setting Source Menu Mode to ON allows scrolling/setting of Source parameters	SOURCE MENU OFF SOURCE MENU ON	OFF* ON	Custom OEM Configurations
Start Power Parameter	START POWER XXXXW	1W to Rated Power (Default: 80W)	Custom OEM Configurations
Idle Power Parameter	IDLE POWER XXXXW	1W to Rated Power (Default:50W)	Custom OEM Configurations
PBN Start I Parameter	PBN START I XXXA	1-999 Amps (Default: 150A)	Custom OEM Configurations
PWR/Beam Factor Parameter	PWR/BEAM FACTOR X	1-6 (Default: 2)	Custom OEM Configurations
Start Sense V Parameter	START SENSE V XXV	0-50 Volts (Default: 50V)	Custom OEM Configurations
Start Detect I Parameter	START DETECT I	0-50 Amps (Default 5A)	Custom OEM Configurations
Start Pulse Voltage Parameter	START PULSE V XXXXV	0-1000 Volts (Default: 1000V)	Custom OEM Configurations
Power 1 Parameter	POWER 1 XXXXW	0W to Rated Power (Default: 70W)	Custom OEM Configurations
Power 2 Parameter	POWER 2 XXXXW	0W to Rated Power (Default: 120W)	Custom OEM Configurations
Power 3 Parameter	POWER 3 XXXXW	0W to Rated Power (Default: 5W)	Custom OEM Configurations
Power 4 Parameter	POWER 4 XXXXW	0W to Rated Power (Default: 25W)	Custom OEM Configurations

PROGRAMMABLE PARAMETER REFERENCE CHART			
PARAMETER	DISPLAY LINE 3	OPTION	Applies To
Power 5 Parameter	POWER 5 XXXXW	0W to Rated Power (Default: 25W)	Custom OEM Configurations
Power 6 Parameter	POWER 6 XXXXW	0W to Rated Power (Default: 25W)	Custom OEM Configurations
Excessive RF Voltage Detection Mode Note: setting Excessive RF Voltage Detection Mode to ON allows scrolling/setting of XRFV parameters	XRFV MODE OFF XRFV MODE ON	OFF* ON	Custom OEM Configurations
Excessive RF Voltage Foldback Point	XRFV FOLD 4200V	0 to 9999 Volts (Default: 4200V)	Custom OEM Configurations
Excessive RF Voltage Standby Power	XRFV STANDBY 300W	0W to Rated Power (Default: 300W)	Custom OEM Configurations
Excessive RF Voltage Re-Light Threshold	XRFV RELIT 2200V	0 to 9999 Volts (Default: 2200V)	Custom OEM Configurations
Excessive RF Voltage "Zero" RF Threshold	0 RF THRESH 250V	0 to 1000 Volts (Default: 250V)	Custom OEM Configurations
Zero RF Delay Time	0 RFDELAY 5S	0 to 30 Seconds (Default: 5 Seconds)	Custom OEM Configurations
Default Power Setpoint	ENT DEFAULT PWR 0	0W to Rated Power (default is 0W)	All
Front Panel Setpoint Active with Analog Control Source Selected	PANEL SET IN REM OFF PANEL SET IN REM ON	OFF* ON	All
Maximum DC Voltage	ENTER MAX DCV XXXXV	0 to 9999V (Default: 1000V)	All
Voltage Feedback Probe Attenuation Factor	ENT PROBE ATTEN XXXX	0 to 9999:1 (Default: 200:1)	All
Excessive Impedance Detection Enable/Disable Note: setting EX IMP Mode to ON allows scrolling/setting of EX IMP parameters	EX IMP MODE ON EX IMP MODE OFF	ON* OFF	Custom OEM Configurations

PROGRAMMABLE PARAMETER REFERENCE CHART			
PARAMETER	DISPLAY LINE 3	OPTION	Applies To
Excessive Impedance Trigger Level	EX IMPEDANCE XXXX	0 to 9999 Ohms (Default:9999)	Custom OEM Configurations
Excessive Impedance Delay	EX IMP DELAY XX S	1 to 99 Seconds (Default: 5S)	Custom OEM Configurations
Arc Suppression Note: Enabling Arc Suppression allows scrolling/setting of Arc Suppression parameters	ARC SUPPRESSION OFF ARC SUPPRESSION DCV ARC SUPPRESSION REF	OFF* DCV REF	All
Arc Suppression Threshold	ARC THR 0V (0) ARC THR 0W(0)	0 to 60000 (Default: 0)	All
Arc Power Reduction Rate	ARC DOUSE 0	0 to 16384 (Default: 0)	All
Arc Sustain Power	ARC SUS 0W (0)	0W to Max Power Parameter (Default: 288W)	All
Arc Suppression Feature Delay-After-RF ON	ARC DELAY 5S	0 to 30 Seconds (Default: 5S)	All
Reflected Power Alarm Threshold	REF PWR ALARM XXXW	1W to 999W (Default: See Detail)	All
Reflected Alarm ON/OFF	REF ALARM ON REF ALARM OFF	ON* OFF	All
Excessive Reflected Power Shut-Off	XRP THRESH OFF XRP THRESH XXXXW	0-9999W or OFF (Default: OFF)	All
Excessive Reflected Power Shut-Off Delay	XRP DELAY 5S	0 to 30 Seconds (Default: 5S)	All
Excessive Reflected Power Threshold Delay	XRP THRSH DLY 0mS	0 to 9999 mS (Default 0 mS)	
Power Control Gain	POWER CONT GAIN XXX%	0% to 100% (Default: 100%)	All
DC Voltage Control Gain	DCV CONT GAIN XXX%	0% to 100% (Default: 100)	All
Matching Network Preset Mode Note: Setting Matching Network Preset Mode to ON allows scrolling and setting of Load and Tune Capacitor Preset Parameters	MATCH PRE INV ON MATCH PRESET ON MATCH PRESET OFF	ON and INVERTED ON OFF*	All

PROGRAMMABLE PARAMETER REFERENCE CHART			
PARAMETER	DISPLAY LINE 3	OPTION	Applies To
Load Capacitor Preset Position	LOAD PRESET XXX %	0% to 100% (Default is 50%)	All
Tune Capacitor Preset Position	TUNE PRESET XXX %	0% to 100% (Default is 50%)	All
Variable Frequency Tuning Note: Setting Variable Frequency Tuning Mode to ON allows scrolling/setting of Variable Frequency Tuning parameters	FREQ TUNE OFF FREQ TUNE ON	OFF* ON	Units configured with adjustable frequency
Coarse Tuning Trip Ratio	ENT COARSE RATIO 10	Variable, 1 to 100, (Default: 10)	Units configured with adjustable frequency
Fine Tuning Trip Level	ENT FINE TRIP 10	1 Watt to Rated Power, Variable (Default 10 Watts)	Units configured with adjustable frequency
Coarse Frequency Step	COARSE FREQ 1000HZ	1Hz to 10,000Hz, Variable (Default: 1000Hz)	Units configured with adjustable frequency
Fine Frequency Step	FINE FREQ 10HZ	1 Hz to 10,000Hz, Variable (Default: 10Hz)	L-Series, R-Series 1.7-2.1MHz
Strike Frequency	STRIKE FREQ XXXXXKHZ	MIN VAR FREQ to MAX VAR FREQ, Variable	Units configured with adjustable frequency
Maximum Allowable Frequency for Variable Frequency Tuning	MAX VAR FREQ XXXXXKHZ	MIN VAR FREQ to MAX VAR FREQ, Variable	Units configured with adjustable frequency
Minimum Allowable Frequency for Variable Frequency Tuning	MIN VAR FREQ XXXXKHZ	MIN VAR FREQ to MAX VAR FREQ, Variable	Units configured with adjustable frequency
Variable Frequency Tuning Feedback Mode	REFL TUNE MODE PHASE TUNE MODE + PHASE TUNE MODE -	REFL TUNE MODE* PHASE TUNE MODE + PHASE TUNE MODE -	Units configured with adjustable frequency

PROGRAMMABLE PARAMETER REFERENCE CHART			
PARAMETER	DISPLAY LINE 3	OPTION	Applies To
Communication Link Watchdog Timer Note: Setting Link Status to ON allows viewing and setting of Link Status Time Parameter	LINK STATUS OFF LINK STATUS ON	OFF* ON	All
Communications Link Status time-out value	LINK TIMEOUT 3S	0 to 3600 Seconds (Default: 3S)	All
Display Last RF-OFF Event	LAST RF-OFF: XXXXX	See Detail	All
Copy all configuration data to flash memory	SAVE CONFIG TO FLASH	Press ENT soft-key to save	All

PROGRAMMABLE PARAMETER DETAILS:

Note: All programmable parameters shown. Not all of the programmable parameters are applicable to all R/LX01 Series models and are notated in the “Applies To” column and in the individual parameter detail descriptions.

Programmable parameters that do not apply to your RF Power Supply type or RF Power Supply configuration will not be displayed when scrolling the menu.

PROGRAMMABLE PARAMETER DETAILS		
PARAMETER	PARAMETER DETAIL	APPLIES TO
Operating Frequency:	Sets the frequency of internal RF signal source. Variable, in 1 KHz steps. <u>Note:</u> For fixed-frequency units, this parameter is displayed but is not adjustable. <u>Related Parameters:</u> Maximum Frequency Minimum Frequency <u>Related Serial Command:</u> FQ	Units configured with adjustable frequency
Maximum Frequency:	Limits the maximum frequency of the internal RF signal source. Variable, in 1 KHz steps. <u>Note:</u> For fixed-frequency units, this parameter is displayed but is not adjustable. The displayed value is the same as the operating frequency. <u>Related Parameters:</u> Operating Frequency Minimum Frequency <u>Related Serial Command:</u> MAXFQ	Units configured with adjustable frequency
Minimum Frequency:	Limits the minimum frequency of the internal RF signal source. Variable, in 1 KHz steps. <u>Note:</u> For fixed-frequency units, this parameter is displayed but is not adjustable. The displayed value is the same as the operating frequency. <u>Related Parameters:</u> Operating Frequency Maximum Frequency <u>Related Serial Command:</u> MINFQ	Units configured with adjustable frequency

PROGRAMMABLE PARAMETER DETAILS

PARAMETER	PARAMETER DETAIL	APPLIES TO
------------------	-------------------------	-------------------

Control Source:	<p>Selects the interface used as the control source for the RF power supply.</p> <p>Factory default setting: PANEL</p>	All
-----------------	--	-----

Panel Control	<p>Selects the front panel keypad as the control source. RF ON and power setpoint commands from the analog interface and Serial interface are ignored.</p> <p>Line 2 of the front panel display shows “PANEL” as the control source.</p> <p><u>Related Serial Command:</u> PANEL</p>	All
---------------	--	-----

Analog Control	<p>Selects the analog interface as the control source. RF ON and power setpoint commands from the front panel and serial interface are ignored.</p> <p><u>Note:</u> The front panel RF ON/OFF button can disable the RF output.</p> <p>Line 2 of the front panel display shows “ANALOG” as the control source.</p> <p><u>Related Parameters:</u> Front Panel Setpoint Active with Analog Control Selected Analog Voltage Range Select</p> <p><u>Related Serial Command:</u> ANALOG</p>	All
----------------	--	-----

PARAMETER	PARAMETER DETAIL	APPLIES TO
-----------	------------------	------------

Serial Control	Selects the Serial, DeviceNet, or ProfiBus interface as the control source. RF ON and power setpoint commands from the front panel interface are ignored. RF ON/OFF and power setpoint commands from the analog interface are ignored.	All
----------------	--	-----

Selecting Serial Control enables access to the serial interface parameters.

Line 2 of the front panel display shows “SERIAL” as the control source.

Operational Note: The front panel RF ON/OFF button can disable the RF output.

Configuration Notes:

- DeviceNet and PROFIBUS are *optional* factory-installed communications interfaces.
- Connections for MODBUS, RS485, RS422, and RS232 communications are made via the rear panel “SERIAL RS232” connector. Refer to the Rear Panel Controls And Connections section for interface wiring details.
- Connections for *optional* DeviceNet communications are made via the rear panel “DEVICENET” connector. Refer to the Rear Panel Controls And Connections section for DEVICENET interface wiring details.
- Connections for the *optional* PROFIBUS interface are made via the rear panel 9-pin “PROFIBUS” connector. If the *optional* PROFIBUS interface is installed, none of the other communications protocols/interfaces are available

Related Parameters:

- Communications Protocol Select
- Address ID Number
- Data Rate
- Communications ECHO
- Communications Watchdog Timer

Related Serial Command: SERIAL

PROGRAMMABLE PARAMETER DETAILS		
PARAMETER	PARAMETER DETAIL	APPLIES TO
Communications Protocol:	<p>Selects the communications interface protocol.</p> <p>Available selections:</p> <p>PROFIBUS (requires <i>optional</i> factory-installed PROFIBUS Interface)</p> <p>DEVICENET (requires <i>optional</i> factory-installed DeviceNet Interface)</p> <p>MODBUS 2W RTU (ModBus 2-Wire)</p> <p>MODBUS 4W RTU (ModBus 4-wire)</p> <p>RS485-2 (RS-485 2-Wire)</p> <p>RS485-4 (RS-485 4-Wire)</p> <p>RS422</p> <p>RS232</p> <p>Factory default setting: RS-232.</p> <p>When RS-485, RS-422, MODBUS, DeviceNet, or ProfiBus is selected, access to the Address ID Number parameter is enabled.</p> <p><u>Related Parameters:</u></p> <p>Control Source</p> <p>Address ID Number</p> <p>Data Rate</p> <p>Communications ECHO</p>	All
Address ID Number	<p>Selects the address ID number for RS-422, RS-485, MODBUS, DeviceNet, and ProfiBus communication protocols.</p> <p>RS-422, RS-485 Address range: 00 to 99</p> <p>MODBUS Address range: 1 to 247</p> <p>DeviceNet Address range: 0 to 64</p> <p>ProfiBus address range: 0 to 126</p> <p>Note: For RS-232 operation on units with older firmware, the programming menu displays the ADDRESS ID parameter when RS-232 protocol is selected. On these units, the Address ID Number must be set to “99”</p> <p>For RS-232 operation on newer units, the ADDRESS ID number parameter is not displayed when RS-232 protocol is selected, and the ADDRESS ID number setting is ignored.</p> <p>Note: For RS-422 and RS-485 operation, if the Address ID number is set to “99”, the unit assumes addressing is not used and will respond to every command.</p> <p>Factory default setting:</p> <p>RS-232, RS-422, RS-485, MODBUS: 99</p> <p>DEVICENET: 63</p> <p>PROFIBUS: 2</p> <p><u>Related Parameters:</u></p> <p>Control Source</p> <p>Communications Protocol Select</p> <p>Data Rate</p> <p>Communications ECHO</p>	All

PARAMETER	PARAMETER DETAIL	APPLIES TO
-----------	------------------	------------

Data Rate:	<p>Selects the Data Rate for RS-232, RS-422, RS-485, MODBUS, and DEVICENET communication protocols. Available data rates displayed depend on the currently selected communications protocol.</p> <p>Available Data Rates for DEVICENET protocol: 500KBPS 250KBPS 125KBPS</p> <p>Note: DeviceNet data rate selections are visible only when DeviceNet protocol is selected. DeviceNet data rate is set via the rear panel data rate switch. With the <i>optional</i> DeviceNet interface is installed, the DeviceNet interface reads the rear panel data rate switch, sets the data rate, and displays the data rate on the front panel display.</p> <p>Available Data Rates for RS-232, RS-422, RS-485, and MODBUS protocols: 115200 BAUD 57600 BAUD 38400 BAUD 19200 BAUD 9600 BAUD 4800 BAUD 2400 BAUD</p> <p>Note: RS-232, RS-422, RS-485, and MODBUS protocols data rate selections are visible only when RS-232, RS-422, RS-485, or MODBUS communication protocols are selected. Other serial communication parameters are not configurable. Parity: None; Data bits: 8; Stop Bits: 1; Handshaking: None</p> <p>Available Data Rates for PROFIBUS Protocol: The PROFIBUS data rate is automatically detected and set to match the PROFIBUS Master. The data rate parameter is not configurable. If the PROFIBUS interface option is installed, and selected, the data rate is displayed as "DATA RATE: AUTOMATIC"</p> <p>Factory Default Setting: DEVICENET: 500KBPS RS232, RS422, RS485, and MODBUS: 19200 BAUD PROFIBUS: AUTOMATIC (not configurable)</p> <p><u>Related Parameters:</u> Control Source Address ID Number Communications Protocol Select Communications ECHO (RS-232, RS-422, RS-485 only)</p>	All
------------	--	-----

PROGRAMMABLE PARAMETER DETAILS		
PARAMETER	PARAMETER DETAIL	APPLIES TO
Serial Communications ECHO	<p>Enables/Disables echoing of serial commands back to the originating communications device. Applicable to RS-232, RS422, RS-485-2, RS485-4 serial communications protocols only.</p> <p>Available settings: ENABLED DISABLED</p> <p>Factory Default setting: DISABLED</p> <p><u>Related Parameters:</u> Communications Protocol Select Address ID Number Data Rate</p> <p><u>Related Serial Commands:</u> ECHO, NOECHO</p>	All
DeviceNet Assembly Set	<p>Selects DeviceNet Assembly Set (data format). The RF Power Supply supports three DeviceNet Assembly Sets, each with different sizes and capabilities, depending on the application.</p> <p>Available Settings:</p> <p style="margin-left: 20px;">DN 5 out 9 in (Assembly Set 1) The amount of data transferred is very small, but control of the RF Power Supply is limited to specifying the setpoint and turning RF power on and off.</p> <p style="margin-left: 20px;">DN 52 out 70 in (Assembly Set 2) Nearly every RF Power Supply function is available, however the amount of data transferred is larger.</p> <p style="margin-left: 20px;">DN 30 out 36 in (Assembly Set 3) Assembly Set 3 is a subset of the functions available with Assembly Set 2, with correspondingly less data transferred.</p> <p>Factory Default setting: DN 5 out 9 in</p> <p><u>Related Parameters:</u> Communications Protocol Select Address ID Number Data Rate</p> <p>Refer to the <i>I/O Poll Command Response Assembly Data Formats</i> topic in the <i>DeviceNet Communications</i> section for expanded technical information.</p>	DeviceNet Configured Units Only

PROGRAMMABLE PARAMETER DETAILS

PARAMETER	PARAMETER DETAIL	APPLIES TO
------------------	-------------------------	-------------------

Pulse Mode:	<p>Enables or Disables internal pulsing of the RF output.</p> <p>When Pulse Mode is enabled, the RF output is pulsed between 0 watts and the power setpoint at the rate specified by Pulse Frequency and Pulse Duty Cycle parameters.</p> <p>Line 2 of the front panel display shows “PLS” as the power control mode.</p>	<p>Units configured for Pulse Type 0, also called “Single-Level” or “High Speed”</p>
-------------	---	--

Operational Notes:

1. Enabling Pulse Mode allows access to pulsing parameters.
2. Pulse Mode is disabled when Leveling Source Select is set to Voltage Control (external feedback).

Factory default setting: DISABLED.

Related Parameters:

- Pulse Frequency
- Pulse Duty Cycle
- Pulse Gate Source

Related Serial Commands: +P, -P

	<p>Enables or Disables internal pulsing of the RF output.</p> <p>When Pulse Mode output is enabled, the RF output is pulsed between the Pulse High Power parameter and the Pulse Low Power parameter at the rate specified by Pulse High Time and Pulse Duty Cycle parameters.</p> <p>Line 2 of the front panel display shows “PLS” as the power control mode.</p>	<p>Units configured for Pulse Type 1, also called “Dual Level” or “Low Speed”</p>
--	--	---

Operational Notes:

1. Enabling Pulse Mode allows access to pulsing parameters.
2. Pulse Mode is disabled when Leveling Source Select is set to Voltage Control (external feedback).

Factory default setting: DISABLED.

Related Parameters:

- Pulse High Power
- Pulse Low Power
- Pulse High Time
- Pulse Duty Cycle
- Pulse Gate Source
- Power Monitor Response

Related Serial Commands: +P, -P

PROGRAMMABLE PARAMETER DETAILS		
PARAMETER	PARAMETER DETAIL	APPLIES TO
Pulse High Power: (Pulse Type 1 Only)	Sets the pulse high power setpoint. Variable, 1 Watt to rated forward output power, in 1-Watt increments. Factory default setting: 0 Watts. <u>Related Parameters:</u> Pulse Low Power Pulse Mode <u>Related Serial Command:</u> HP	Units configured for Pulse Type 1
Pulse Low Power: (Pulse Type 1 Only)	Sets the pulse low power level. Variable, 0 Watts to rated forward output power, in 1-Watt increments. Factory default setting: 0 Watts. <u>Related Parameters:</u> Pulse High Power Pulse Mode <u>Related Serial Command:</u> LP	Units configured for Pulse Type 1
Pulse Frequency (Pulse Type 0 Only)	Sets the pulse repetition rate in Hertz. The pulse frequency is variable from 1 Hz to 10,000 Hz, in 1-Hz increments. Factory default setting: 1,000 Hz <u>Related Parameters:</u> Pulse Duty Cycle Pulse Mode <u>Related Serial Command:</u> PR	Units configured for Pulse Type 0
Pulse High Time: (Pulse Type 1 Only)	Sets the high pulse duration, in milliseconds. The pulse high time can be varied from 1mS to 9999mS, in 1-mS increments. Factory default setting: 5mS. <u>Related Parameters:</u> Pulse High Power Pulse Low Power Pulse Duty Cycle Pulse Mode <u>Related Serial Command:</u> HT	Units configured for Pulse Type 1

PARAMETER	PARAMETER DETAIL	APPLIES TO
-----------	------------------	------------

Pulse Duty Cycle:	<p>Sets the “ON” duration of the RF output pulse, in relation to the pulse repetition rate. The “ON” duration can be varied from 1% to 100%, in 1% increments.</p> <p>Factory default setting: 50%.</p> <p><u>Related Parameters:</u></p> <ul style="list-style-type: none"> Pulse High Time (Pulse Type 1) Pulse Frequency (Pulse Type 0) Pulse Mode <p><u>Related Serial Command:</u> D</p>	All
-------------------	--	-----

Pulse Source	<p>Selects the pulse gate (timing) source.</p> <p>Set to “INTERNAL” to use the unit’s internal pulse generator.</p> <p>Set to “EXTERNAL” to use the signal applied to the Analog Interface connector’s “GATE” signal as the pulse source.</p> <p><u>Operational Note:</u></p> <p>When the Pulse Source is set to EXTERNAL, the Pulse Frequency, Pulse High Time, and Pulse Duty Cycle parameters are ignored.</p> <p>Factory default setting: INTERNAL</p> <p><u>Related Parameters:</u></p> <ul style="list-style-type: none"> Pulse Frequency, Pulse High Time Pulse Duty Cycle, Pulse Mode 	All
--------------	---	-----

PROGRAMMABLE PARAMETER DETAILS

PARAMETER	PARAMETER DETAIL	APPLIES TO
Power Monitor Response	<p>Selects the Analog Interface connector's Power Monitor output response when Dual-Level (Pulse Type 1) Pulse Mode is enabled.</p> <p>PEAK Response: The Analog Interface power monitors deliver a steady-state signal, equivalent to the peak forward RF output power and peak reflected power.</p> <p>REAL Response: The Analog Interface forward power monitor and reflected power monitor signals alternate between the "high" and "low" pulse powers (tracks the RF output envelope).</p> <p>Factory default setting: PEAK</p> <p><u>Operational Note:</u> The REAL response of the power monitor output <i>is not</i> precise. The transition time from one monitor voltage to the other will be no less than 100 milli-seconds.</p> <p>If the Pulse High Time parameter is set to at least 200 milli-seconds and the duty cycle is set to 50%, the power monitor output will roughly follow the RF output envelope. With shorter Pulse High Time settings, the power monitor outputs will not be able to track the RF output envelope, but will alternate between the two monitor voltages at a slower rate.</p> <p><u>Related Parameters:</u> Pulse Mode Pulse High Time Pulse Duty Cycle</p>	Units configured for Pulse Type 1

RF Output Ramping Mode	<p>Enables or disables ramping of the RF output when the RF output is enabled or disabled.</p> <p><u>Operational Notes:</u></p> <ol style="list-style-type: none"> 1. Setting RAMP MODE to "ON" allows access to the ramping parameters. 2. Ramp Mode is disabled when Pulse Mode is active or when the Output Regulation Mode is set to Voltage Control or Current Control (external feedback). <p>RF output Ramp Mode is also configurable via the serial interface. Factory default setting: OFF</p> <p><u>Related Parameters:</u> Ramp On Time Ramp Off Time</p> <p><u>Related Serial Commands:</u> EU, DU</p>	All
------------------------	---	-----

PARAMETER	PARAMETER DETAIL	APPLIES TO
-----------	------------------	------------

Ramp On Time	<p>Specifies the Ramp-Up time interval.</p> <p>When the RF output is enabled (by the front panel, analog interface or serial command), the RF output power is increased from 0 Watts to the power setpoint over the specified time interval.</p> <p>RF output Ramp-Up time is also configurable via the serial interface.</p> <p>Ramp-Up Time Range: 0 to 9999 seconds, in 1-second increments.</p> <p>Factory default setting: 1S</p> <p><u>Related Parameters:</u> Ramp Mode Ramp Off Time</p> <p><u>Related Serial Command:</u> UP</p>	All
--------------	---	-----

Ramp Off Time	<p>Specifies the Ramp-Down time interval.</p> <p>When the RF output is enabled (by the front panel, analog interface or serial command), the RF output power is decreased from the power setpoint to 0 Watts over the specified time interval.</p> <p>RF output Ramp-Down time is also configurable via the serial interface.</p> <p>Ramp-Up Time Range: 0 to 9999 seconds, in 1-second increments.</p> <p>Factory default setting: 1S</p> <p><u>Related Parameters:</u> Ramp Mode Ramp On Time</p> <p><u>Related Serial Command:</u> DN</p>	All
---------------	--	-----

PROGRAMMABLE PARAMETER DETAILS		
PARAMETER	PARAMETER DETAIL	APPLIES TO
Output Regulation Mode Select:	Selects the feedback source used to regulate the RF output level. Factory default setting: POWER CONTROL	All
POWER CONTROL	<p>Uses the RF Power Supply's internal power sensor as the feedback source for regulating the RF output level.</p> <p>Line 1 of the front panel display indicates forward power setpoint, in Watts, when the RF output is off; indicates Forward or Load power when the RF output is enabled.</p> <p>Line 2 of the front panel display indicates "PWR" when POWER CONTROL is selected.</p> <p><u>Related Serial Command:</u> IR</p>	All
VOLTAGE CONTROL	<p>Uses the analog interface connector's FEEDBACK signal as the feedback source for regulating the RF output level.</p> <p>Line 1 of the front panel display indicates the voltage setpoint, in Volts, when the RF output is off; indicates Probe Voltage when the RF output is enabled.</p> <p>Line 2 of the front panel display indicates "VLT" when VOLTAGE CONTROL is selected.</p> <p><u>Operational Notes:</u></p> <ol style="list-style-type: none"> 1. Setting the Leveling Source to VOLTAGE CONTROL disables Pulsing and Ramping modes. 2. Setting the Leveling Source to VOLTAGE CONTROL enables viewing and configuring of the Probe Inverter feature on Models R/L101MKII and R/L301MKII. <p><u>Related Parameters:</u></p> <ul style="list-style-type: none"> Analog Voltage Range Select Probe Inversion Voltage Limit <p><u>Related Serial Command:</u> DR</p>	All

PROGRAMMABLE PARAMETER DETAILS

PARAMETER	PARAMETER DETAIL	APPLIES TO
-----------	------------------	------------

CURRENT CONTROL	Uses the analog interface connector's FEEDBACK signal as the feedback source for regulating the RF output level.	All
-----------------	--	-----

Line 1 of the front panel display indicates the current setpoint, in Amps, when the RF output is off; indicates Probe Current when the RF output is enabled.

Line 2 of the front panel display indicates "CUR" when CURRENT CONTROL is selected.

Operational Notes:

1. Setting the Leveling Source to CURRENT CONTROL disables Pulsing and Ramping modes.
2. Setting the Leveling Source to CURRENT CONTROL enables viewing and configuring of the Probe Inverter feature on Models R/L101MKII and R/L301MKII

Related Parameters:

Analog Voltage Range Select
Probe Inversion

Related Serial Command: CURR

Voltage Limit	Disables/Enables and sets the voltage limit. Available in Power Control Mode only. Used in conjunction with the analog interface connector's DC Feedback input (DC probe).	All
---------------	--	-----

Note: The Probe Attenuation setting is applicable. If the Probe Attenuation factor is set to 100 and a 2.0VDC signal is applied to the DC Feedback signal input (pin 12 on the 25-pin Analog Interface connector), the probe voltage is treated as 200V.

If the voltage limit setting is non-zero and the probe voltage exceeds the Voltage Limit setting, the RF power supply decreases output power until the probe voltage no longer exceeds the Voltage Limit setting.

Voltage Limit range: OFF, 1V to 1000V

Factory default setting: OFF

Related Parameters:

Power Control
Analog Voltage Range Select
Probe Attenuation
Probe Inversion

Related Serial Command: MAXPV

PROGRAMMABLE PARAMETER DETAILS		
PARAMETER	PARAMETER DETAIL	APPLIES TO
Probe Inversion	<p>Enables or disables internal routing of the output of the DCP Connector probe inverter feature to the Analog Interface connector's FEEDBACK signal.</p> <p>Note: Only available on R/L101MKII and R/L301MKII models with Software Version 9.0J3 and later.</p> <p>Factory default setting: VLT CNTRL +PRB DB25</p> <p><u>Related Parameters:</u> Control Source / Analog Analog Voltage Range Select Leveling Source Select / Voltage Control, Current Control VLT CNTRL +PRB DB25 VLT CNTRL -PRB BNC</p>	R/L101MKII, R/L301MKII Only
VLT CNTRL +PRB DB25	<p>Disables the probe inversion feature.</p> <p>Any signal applied to the rear panel DCP connector is ignored.</p> <p>A positive (+) polarity external feedback (probe) signal applied to the Analog Interface connector (type DB25) FEEDBACK signal (pin 12) is used for external feedback when the Output Regulation Mode Select parameter is set to Voltage Control or Current Control.</p>	R/L101MKII, R/L301MKII Only
VLT CNTRL -PRB BNC	<p>Routes the output of the probe inverter to the Analog Interface connector's FEEDBACK SIGNAL.</p> <p>A negative (-) polarity external feedback signal applied to the DCP connector (type BNC) is used for external feedback when the Output Regulation Mode Select parameter is set to Voltage Control or Current Control.</p> <p><u>Operational Note:</u> The output of the probe inverter <i>is present</i> at pin 12 (FEEDBACK signal) of the Analog Interface connector. This signal may be used by the user's system for remote monitoring.</p> <p>Caution: When using the probe inverter signal at pin 12 of the Analog Interface connector (FEEDBACK signal) for remote monitoring purposes, take care to properly shield the connection and do not short the signal to ground. The RF Power supply is using this signal to regulate its power output. Applying noise or other signals sources to the FEEDBACK signal pin may cause the unit's output to behave erratically or produce unexpected process results.</p>	R/L101MKII, R/L301MKII Only

PROGRAMMABLE PARAMETER DETAILS		
PARAMETER	PARAMETER DETAIL	APPLIES TO
Analog Voltage Range Select:	<p>Selects the Full-Scale voltage for the analog interface's SETPOINT and FEEDBACK inputs, and the analog interface's FWD MON (Forward Power monitor) and REFP MON (Reflected Power monitor) outputs.</p> <p>Available selections:</p> <p style="margin-left: 20px;">RANGE 5V F.S. Sets +5.0VDC as the full-scale voltage</p> <p style="margin-left: 20px;">RANGE 10V F.S. Sets +10.0VDC as the full-scale voltage</p> <p>Factory default setting: RANGE 5V F.S.</p> <p><u>Related Parameters:</u></p> <p style="margin-left: 20px;">Control Source / Analog Leveling Source Select</p>	All
Power Leveling Select:	<p>Selects the method used to regulate the unit's RF output power when the Output Regulation Mode Select parameter is set to POWER CONTROL.</p> <p>Factory default setting: FWD POWER LEVELING</p>	All
FWD POWER LEVELING	<p>Regulates the RF output power based solely on the forward power feedback signal.</p> <p>The front panel display and the analog interface's FWD MON (forward power monitor) signal indicate the amount of forward power delivered to the load.</p> <p><u>Related Serial Command:</u> DL</p>	All
LOAD POWER LEVELING	<p>Regulates the RF output power based on the net power delivered to the load. (Forward Power – Reflected Power = Net Power).</p> <p>The front panel display and the analog interface's FWD MON (forward power monitor) signal indicate the amount of net power delivered to the load.</p> <p><u>Related Serial Command:</u> EL</p>	All

PROGRAMMABLE PARAMETER DETAILS		
PARAMETER	PARAMETER DETAIL	APPLIES TO
Output Power Range Select:	<p>HIGH RANGE sets the unit's output power range from 0% to 100% of the unit's rated power output, with standard power setpoint and power metering resolution.</p> <p>LOW RANGE sets the unit's output power range from 0% to 10% of the unit's rated power output, with enhanced power setpoint and power metering resolution.</p> <p>Factory default setting: HIGH RANGE</p> <p><u>Operational Note:</u> Custom-configured units may have a different Low Range scale. Example: 0% to 30%</p> <p><u>Related Serial Commands:</u> HR, LR</p>	R/L101MKII, R/L301MKII, R/L601
Exciter Mode (Frequency Source) Select:	<p>EXCITER- MASTER:</p> <p>The unit uses its internal frequency source to generate the RF output signal. In "master" mode, the internal frequency source is available at the CEX OUT connector on the rear panel.</p> <p><u>Related Serial Command:</u> MST</p> <p>EXCITER- SLAVE:</p> <p>The unit uses the rear panel CEX IN signal as the frequency source for the RF output signal. "Slave" Mode is used in systems with multiple RF power supplies; with one RF power supply as the master and the other power supplies operating as "slaves".</p> <p>This configuration is used to keep the power supplies synchronized, thus preventing or minimizing RF circulating currents within the processing system. In "slave" mode, the CEX IN signal is routed to the rear panel CEX OUT connector.</p> <p>Factory default setting: EXCITER – MASTER</p> <p><u>Related Serial Command:</u> SLV</p>	All
Maximum Output Power:	<p>Allows the user limit the maximum RF output power.</p> <p>Limit is adjustable between 1 Watt and rated output power, in 1-Watt increments. When the output power setpoint is equal to the MAX POWER value, "MAX" is indicated on the front panel display, line 2, right-hand side.</p> <p>Factory default setting: Rated Output Power</p>	All

PROGRAMMABLE PARAMETER DETAILS		
PARAMETER	PARAMETER DETAIL	APPLIES TO
Source Menu Enable/Disable	<p>Enables display of the Source Parameter menu options.</p> <p>When set to “ON”, the Source Parameters are displayed as the next steps in the menu. Users may scroll the source parameters with the menu UP/DOWN buttons and adjustments to the settings may be preformed.</p> <p>When set to “OFF”, the Source Parameters are not displayed and pressing the menu UP/DOWN buttons skips over the source parameters.</p> <p><u>Operational Note:</u> The Source Parameters do not have any direct effect on the operation or performance of the RF Power Supply. The Source Parameter data is stored within the unit’s memory, for retrieval by commands sent to the unit via the serial interface. Refer to the Serial Interface Operation section for serial command details.</p> <p>Factory default setting: SOURCE MENU ENABLED</p>	Custom OEM Configurations
Start Power Parameter	<p>Start Power recallable parameter. Variable, 1W to rated output power, in 1-Watt increments.</p> <p>Factory default setting: 80W</p> <p><u>Related Parameters:</u> Source Menu Enable/Disable</p> <p><u>Related Serial Command:</u> CGP? Use the serial command “CGP?” to read the current parameter value. Refer to the Serial Commands section for a detailed explanation of the “CGP?” command.</p>	Custom OEM Configurations
Idle Power Parameter	<p>Idle Power recallable parameter. Variable, 1W to rated output power, in 1-Watt increments.</p> <p>Factory default setting: 50W</p> <p><u>Related Parameters:</u> Source Menu Enable/Disable</p> <p><u>Related Serial Command:</u> CGP? Use the serial command “CGP?” to read the current parameter value. Refer to the Serial Commands section for a detailed explanation of the “CGP?” command.</p>	Custom OEM Configurations

PROGRAMMABLE PARAMETER DETAILS		
PARAMETER	PARAMETER DETAIL	APPLIES TO
PBN Start I Parameter	<p>PBN Start I recallable parameter. Variable, 1-999 Amps, in 1-Amp increments.</p> <p>Use the serial command “CGP?” to read the current parameter value. Refer to the Serial Commands section for a detailed explanation of the “CGP?” command.</p> <p>Factory default setting: 150A</p> <p><u>Related Parameters:</u> Source Menu Enable/Disable</p> <p><u>Related Serial Command:</u> CGP?</p>	Custom OEM Configurations
PWR/Beam Factor Parameter	<p>PWR/Beam Factor recallable parameter. Variable, 1 to 6, in increments of 1.</p> <p>Use the serial command “CGP?” to read the current parameter value. Refer to the Serial Commands section for a detailed explanation of the “CGP?” command.</p> <p>Factory default setting: 2</p> <p><u>Related Parameters:</u> Source Menu Enable/Disable</p> <p><u>Related Serial Command:</u> CGP?</p>	Custom OEM Configurations
Start Sense V Parameter	<p>Start Sense V recallable parameter. Variable 0 to 50 Volts, in 1-volt increments.</p> <p>Use the serial command “CSP?” to read the current parameter value. Refer to the Serial Commands section for a detailed explanation of the “CSP?” command.</p> <p>Factory default setting: 50V</p> <p><u>Related Parameters:</u> Source Menu Enable/Disable</p> <p><u>Related Serial Command:</u> CGP?</p>	Custom OEM Configurations
Start Detect I Parameter	<p>Start Detect I recallable parameter. Variable, 0 to 50 Amps, in 1-Amp increments.</p> <p>Use the serial command “CSP?” to read the current parameter value. Refer to the Serial Commands section for a detailed explanation of the “CSP?” command.</p> <p>Factory default setting: 5A</p> <p><u>Related Parameters:</u> Source Menu Enable/Disable</p> <p><u>Related Serial Command:</u> CSP?</p>	Custom OEM Configurations

PROGRAMMABLE PARAMETER DETAILS		
PARAMETER	PARAMETER DETAIL	APPLIES TO
Start Pulse Voltage Parameter	<p>Start Pulse Voltage recallable parameter. Variable, 1 to 1000 Volts, in 1-Volt increments.</p> <p>Use the serial command “CSP?” to read the current parameter value. Refer to the Serial Commands section for a detailed explanation of the “CSP?” command.</p> <p><u>Related Parameters:</u> Source Menu Enable/Disable Factory default setting: 1000V <u>Related Serial Command:</u> CSP?</p>	Custom OEM Configurations
Power 1 Parameter	<p>Power 1 recallable parameter. Variable, 0 Watts to rated output power, in 1-watt increments.</p> <p>Use the serial command “P1?” to read the current parameter value. Refer to the Serial Commands section for a detailed explanation of the “P1?” command.</p> <p><u>Related Parameters:</u> Source Menu Enable/Disable Factory default setting: 70W <u>Related Serial Command:</u> P1?</p>	Custom OEM Configurations
Power 2 Parameter	<p>Power 2 recallable parameter. Variable, 0 Watts to rated output power, in 1-watt increments.</p> <p>Use the serial command “P2?” to read the current parameter value. Refer to the Serial Commands section for a detailed explanation of the “P2?” command.</p> <p><u>Related Parameters:</u> Source Menu Enable/Disable Factory default setting: 120W <u>Related Serial Command:</u> P2?</p>	Custom OEM Configurations
Power 3 Parameter	<p>Power 3 recallable parameter. Variable, 0 Watts to rated output power, in 1-watt increments.</p> <p>Use the serial command “P3?” to read the current parameter value. Refer to the Serial Commands section for a detailed explanation of the “P3?” command.</p> <p>Factory default setting: 5W</p> <p><u>Related Parameters:</u> Source Menu Enable/Disable <u>Related Serial Command:</u> P3?</p>	Custom OEM Configurations

PROGRAMMABLE PARAMETER DETAILS		
PARAMETER	PARAMETER DETAIL	APPLIES TO
Power 4 Parameter	<p>Power 4 recallable parameter. Variable, 0 Watts to rated output power, in 1-watt increments.</p> <p>Use the serial command “P4?” to read the current parameter value. Refer to the Serial Commands section for a detailed explanation of the “P4?” command.</p> <p>Factory default setting: 25W</p> <p><u>Related Parameters:</u> Source Menu Enable/Disable</p> <p><u>Related Serial Command:</u> P4?</p>	Custom OEM Configurations
Power 5 Parameter	<p>Power 5 recallable parameter. Variable, 0 Watts to rated output power, in 1-watt increments.</p> <p>Use the serial command “P5?” to read the current parameter value. Refer to the Serial Commands section for a detailed explanation of the “P5?” command.</p> <p>Factory default setting: 25W</p> <p><u>Related Parameters:</u> Source Menu Enable/Disable</p> <p><u>Related Serial Command:</u> P5?</p>	Custom OEM Configurations
Power 6 Parameter	<p>Power 6 recallable parameter. Variable, 0 Watts to rated output power, in 1-watt increments.</p> <p>Use the serial command “P6?” to read the current parameter value. Refer to the Serial Commands section for a detailed explanation of the “P6?” command.</p> <p>Factory default setting: 25W</p> <p><u>Related Parameters:</u> Source Menu Enable/Disable</p> <p><u>Related Serial Command:</u> P6?</p>	Custom OEM Configurations
Default Power Setting:	<p>Allows the user to configure the default power-on output power setpoint. Variable, 0 Watts to rated power, in 1-Watt increments.</p> <p>Factory default setting: 0 Watts.</p>	All

PROGRAMMABLE PARAMETER DETAILS		
PARAMETER	PARAMETER DETAIL	APPLIES TO

Front Panel Setpoint Active with Analog Control Selected:

When this parameter is set to PANEL SET IN REM OFF, and the control source is set to "ANALOG" (via the front panel or through the serial interface), the power setpoint cannot be adjusted from the front panel. The power setpoint is adjusted via the analog interface connector's SETPOINT signal.

All

When this parameter is set to PANEL SET IN REM ON, and the control source is set to "ANALOG" (via the front panel or through the serial interface), the front panel power setpoint adjustment is active. The analog interface connector's SETPOINT signal is ignored.

Operational Note: This parameter has no effect if the control source is set to SERIAL or PANEL.

Factory default setting: PANEL SET IN REM OFF.

Related Parameters:
Control Source / Analog

Maximum DC Voltage

Allows the user limit the Voltage Setpoint while the Output Regulation Mode is set to Voltage Control.

All

Limit is adjustable between 1 Volt and 9999V, in 1-Volt increments.

When the Voltage Setpoint is equal to the MAX DCV value, "MAX" is indicated on the front panel display, line 2, right-hand side.

Related Parameters:
Voltage Feedback Probe Attenuation Factor
Factory default value: 9999V.

PARAMETER	PROGRAMMABLE PARAMETER DETAILS	APPLIES TO
-----------	--------------------------------	------------

Voltage Feedback Probe Attenuation Factor:	Used when regulating the unit's RF output with an external feedback signal. Setting the attenuation factor to match the external system's probe attenuation factor allows the RF Power Supply to directly display the feedback signal in Volts.	All
--	---	-----

External feedback voltages are derived from the processing system and can range from tens of Volts to thousands of Volts. Because it is not practical or safe to use high-voltage control signals, and the RF Power Supply's maximum external feedback input voltage is 10VDC, and an attenuator probe is used in most systems.

The external system's attenuator probe is calibrated, and the calibration is specified as a ratio. Adjust the RF Power Supply's voltage feedback probe attenuation factor to match the system's voltage probe attenuation ratio.

Connect the external feedback signal to the Analog Interface Connector's FEEDBACK signal input.

Related Parameters:

Output Regulation Mode / Voltage Control or Current Control
Maximum DC Voltage

Factory default value: 200:1

Excessive Impedance Detection (XIMP) Enable/Disable	Excessive Impedance Detection (XIMP) feature is designed to detect a "no plasma" condition in the user's plasma chamber and disable the RF output.	Custom OEM Configurations
---	--	---------------------------

When enabled (on), the RF Power Supply calculates the plasma impedance based on the formula:

$$E^2/P = Z$$

Where P is the forward RF power output, E is the external feedback voltage from an external RF probe (installed in an external impedance matching network) applied to the Analog Interface FEEDBACK signal, and Z is the calculated impedance.

When the RF output is enabled, plasma impedance (Z) calculation is suspended until the RF output has been active for a time equal to XIMP delay parameter. After the XIMP Delay, the plasma impedance (Z) is continuously calculated.

PARAMETER	PARAMETER DETAIL	APPLIES TO
-----------	------------------	------------

If the calculated plasma impedance (Z) is greater than the Excessive Impedance Trigger level (XIMP Trigger), the RF output is disabled and an "XIMP" alarm message appears on line 2 of the front panel display. The "XIMP" alarm message clears when the RF output is re-enabled.

When XIMP detection is disabled (off), the plasma impedance is not calculated and the XIMP Trigger level is ignored.

Operational Note:

Excessive Impedance (XIMP), Excessive RF Voltage (XRFV), and Excessive Reflected Power (XRP) parameter functions are mutually exclusive - only one of the 3 functions can be enabled at any given time

Related Parameters:

- Excessive Impedance (XIMP) Trigger
- Excessive Impedance (XIMP) Delay

Factory default setting: XIMP ON

Excessive Impedance (XIMP) Trigger	Calculated plasma impedances greater than the trigger value will disable the RF power Supply's output. Variable, 1 Ohm to 9999 Ohms, in 1-Ohm increments.	Custom OEM Configurations
------------------------------------	---	---------------------------

Related Parameters:

- Excessive Impedance (XIMP) Detection Enable/Disable
- Excessive Impedance (XIMP) Delay

Factory default setting: XIMP TRIGGER 1000 OHMS

Excessive Impedance (XIMP) Delay	Sets the time delay between RF ON and the comparison of plasma impedance and XIMP Trigger level. Variable, 1 to 99 seconds, in 1-second increments.	Custom OEM Configurations
----------------------------------	---	---------------------------

Related Parameters:

- Excessive Impedance (XIMP) Detection Enable/Disable
- Excessive Impedance (XIMP) Trigger

Factory default setting: 10 S

PROGRAMMABLE PARAMETER DETAILS		
PARAMETER	PARAMETER DETAIL	APPLIES TO

Arc Suppression

Enables/Disables Arc suppression feature and selects the mode of operation.

All

The arc suppression feature detects arcing in the load and reduces the RF power output until arcing stops. Configurable parameters are available to set the arc detection threshold, rate of power reduction, minimum power output while arcing is occurring, and amount of time the unit will wait until after RF is enabled before checking for arcing.

The correct values for some or all of the arc suppression feature's parameters need to be determined empirically. To find useable values for the parameters, it is advisable to first run the system with arc suppression disabled and observe the system's behavior.

When using the Arc Suppression feature, the Power Control Gain parameter value should be set as low as possible, but not so low that it takes too long for the unit's output to reach its setpoint. If the Power Control Gain parameter value is too high, the unit's output may increase too quickly after suppressing an arc and re-establish arcing. The appropriate Power Control Gain parameter value must be empirically established.

Once initial values have been selected for ARC DELAY, ARC SUSTAIN, and POWER CONTROL GAIN, enable the arc suppression feature and adjust the remaining settings for desired operation.

Factory default setting: ARC SUPPRESSION OFF

Operational Note: The Arc Suppression feature must be enabled to access the other parameters related to arc suppression.

Arc Suppression feature implemented with firmware 11.3G00.
Arc Suppression DCV Mode implemented with firmware 11.3K00

Related Parameters:

- Arc Suppression Threshold
- Arc Power Reduction Rate
- Arc Sustain Power
- Arc Suppression Delay-After-RF ON
- Power Control Gain
- DC Voltage Control Gain

PROGRAMMABLE PARAMETER DETAILS		
PARAMETER	PARAMETER DETAIL	APPLIES TO
ARC SUPPRESSION OFF	Arc suppression feature disabled.	All
ARC SUPPRESSION DCV	<p>Arc Suppression Enabled – DC Voltage Mode</p> <p>The unit senses a change in the DC feedback voltage applied the analog interface PROBE input and operates on the assumption that a decrease in the feedback voltage (DC feedback voltage is below the setpoint voltage) indicates arcing.</p> <p><u>Operational Note:</u> Arc Suppression DC Voltage Mode requires a developed DC voltage while power is delivered to the load (DC Bias), and the unit must be configured for Voltage Control operation.</p> <p><u>Related Parameters:</u> Leveling Source Select Analog Voltage Range Select Voltage Feedback Probe Attenuation Factor DC Voltage Control Gain</p>	All
ARC SUPPRESSION REF	<p>Arc Suppression Enabled – Reflected Power Mode</p> <p>The unit monitors reflected power and operates on the assumption that an increase in reflected power above a user-settable threshold indicates arcing.</p>	All

PARAMETER	PARAMETER DETAIL	APPLIES TO
-----------	------------------	------------

Arc Suppression Threshold

Reflected Power Mode (ARC SUPPRESSION REF)

All

ARC THR 0W (0)

Threshold range: 0 to 60000

Factory default setting: 0W

If the reflected power is greater than the parameter value, the unit assumes arcing is occurring and the Arc Suppression feature is triggered.

The value in parenthesis is the reading from the unit's analog-to-digital converter that corresponds to the reflected power (in Watts) as shown.

The Arc Suppression Threshold parameter value must be greater than the highest reflected power expected/allowed without arcing. Otherwise, a normal or tolerable amount reflected power might cause an unwanted reduction in power.

DC Voltage Mode (ARC SUPPRESSION DCV)

ARC THR 0V (0)

Threshold range: 0 to 60000

Factory default setting: 0V

If the DC Feedback voltage falls below the unit's voltage setpoint by the threshold amount, the unit assumes arcing is occurring and the Arc Suppression feature is triggered.

The value displayed in parenthesis is the reading from the unit's analog-to-digital converter that corresponds to the value of threshold voltage.

The threshold value is relative to the unit's voltage setpoint. A useful initial setting may be approximately 5% of the voltage setpoint value.

Related Parameters:

- Arc Suppression
- Arc Power Reduction Rate
- Arc Sustain Power
- Arc Suppression Delay-After-RF ON

PROGRAMMABLE PARAMETER DETAILS

PARAMETER	PARAMETER DETAIL	APPLIES TO
-----------	------------------	------------

Arc Power Reduction Rate	<p>This parameter determines the rate of power reduction applied while an arc is occurring.</p> <p style="margin-left: 20px;">ARC DOUSE 0</p> <p style="margin-left: 40px;">Douse Value Range: 0 to 16384</p> <p style="margin-left: 40px;">Factory default setting: 0</p>	All
--------------------------	--	-----

The ARC DOUSE value is the amount subtracted from the unit's power output digital-to-analog converter setting each time the arc suppression algorithm runs through a measurement cycle. Regardless of the ARC DOUSE value, the unit's power output will not be reduced below the arc sustain (ARC SUS) value.

Note: If it is possible to cause arcing at will, start with a DOUSE setting of zero (0), induce arcing periodically and increase the DOUSE setting until arcing is reduced.

Related Parameters:

- Arc Suppression
- Arc Suppression Threshold
- Arc Sustain Power
- Arc Suppression Delay-After-RF ON
- Power Control Gain
- DC Voltage Control Gain

Arc Sustain Power	<p>Establishes the minimum power the unit should attempt to maintain while arcing is occurring.</p> <p style="margin-left: 20px;">ARC SUS 0W (0)</p> <p style="margin-left: 40px;">Sustain power range: 0W to Max Power Parameter value.</p> <p style="margin-left: 40px;">Factory default setting: 0W</p>	All
-------------------	---	-----

The value in parenthesis is the power output digital-to-analog converter setting that normally causes the unit to produce the power shown.

The ARC SUS value depends on:

1. Whether or not it is desirable for the unit to maintain a minimum output power while an arc is occurring.
2. Minimum power required to sustain plasma while the unit attempts to suppress the arc.

Related Parameters:

- Arc Suppression
- Arc Suppression Threshold
- Arc Power Reduction Rate
- Arc Suppression Delay-After-RF ON

PROGRAMMABLE PARAMETER DETAILS

PARAMETER	PARAMETER DETAIL	APPLIES TO
-----------	------------------	------------

Arc Suppression Delay-After-RF ON	Specifies the amount of time the Arc Suppression feature is held inactive <u>after</u> the RF output is enabled. Allows the system/process to attain a stable operating point before the Arc Suppression feature is activated.	All
-----------------------------------	--	-----

ARC DELAY 5S
 Delay range: 0 to 30 Seconds
 Factory Default setting: 5S

Note: The ARC DELAY value is system/process dependant. Empirically determine the time required to reach a stable operating point after the RF output is enabled, and set the ARC DELAY parameter accordingly.

Related Parameters:
 Arc Suppression
 Arc Suppression Threshold
 Arc Power Reduction Rate
 Arc Sustain Power
 Power Control Gain

Reflected Power Alarm Threshold:	Allows the user to set a threshold for indicating a high-reflected power condition. Adjustable between 1 and 999 Watts, in 1-Watt increments.	All
----------------------------------	---	-----

When the alarm threshold is met or exceeded, “REF” is indicated on line 2 of the front panel display and the status of the analog interface connector RFENABLED* signal (pin 8) is changed from a TTL logic low (0) state to a TTL logic high (1) state.

To disable changing of the RFENABLED* signal status, set the alarm threshold greater than the unit’s maximum reflected power limit or set the reflected alarm (REF ALARM) parameter to OFF

Note: The reflected power alarm message (REF) will always be displayed if the unit’s maximum reflected power limit is reached.

Factory default setting: Maximum reflected power limit.
 See the Technical Specifications section for your RF Power Supply Model type.

Related Parameters:
 Reflected Alarm ON/OFF

PROGRAMMABLE PARAMETER DETAILS		
PARAMETER	PARAMETER DETAIL	APPLIES TO
Reflected Alarm ON/OFF:	<p>REF ALARM ON: Enables changing of the analog interface connector's RFENABLED* signal (pin 8) state when the maximum reflected power limit is reached or when the Reflected Power Alarm threshold has been reached.</p> <p>REF ALARM OFF: Disables changing of the analog interface connector's RFENABLED* signal (pin 8) state when the maximum reflected power limit is reached or when the Reflected Power Alarm threshold has been reached.</p> <p>Factory default setting: REF ALARM ON</p> <p><u>Related Parameters:</u> Reflected Power Alarm Threshold</p>	All

PARAMETER	PARAMETER DETAIL	APPLIES TO
-----------	------------------	------------

Excessive Reflected Power Shut-Off	<p>The Excessive Reflected Power (XRP) feature automatically disables RF output if reflected power exceeds a user-settable threshold.</p> <p style="margin-left: 20px;">XRP THRESH OFF XRP THRESH XXXXW</p> <p style="margin-left: 40px;">Value range: 0-9999W or OFF Factory default setting: OFF</p> <p>Activation of the Excessive Reflected Power feature can be delayed to allow the system/process to attain a stable operating point. The delay is user-adjustable. Refer to the Excessive Reflected Power Shut-Off Delay parameter.</p> <p>If reflected power exceeds the XRP THRESH parameter value, the XRP feature disables the RF output and displays an “XRP” alarm message on the second line of the front panel display. The XRP alarm message will remain on the front panel display until the RF output is re-enabled.</p>	All
------------------------------------	--	-----

Operational Notes:

1. Setting the XRP THRESH parameter value to zero (0) disables the feature.
2. The unit has an internal, factory-set reflected power limit protection circuit. The actual reflected power limit value depends on the model type. Refer to the specification section to determine the reflected power limit for the model of interest. If the reflected power reaches the factory-set limit, the unit reduces the RF output power to a safe level, but does not disable RF output. If the XRP THRESH parameter is set to a value greater than the internal protective limit, the XRP feature will be effectively disabled.
3. Excessive Impedance (XIMP), Excessive RF Voltage (XRFV), and Excessive Reflected Power (XRP) parameter functions are mutually exclusive - only one of the 3 functions can be enabled at any given time

Excessive Reflected Power implemented with firmware 11.5C00

Related Parameters:

Excessive Reflected Power Shut-Off Delay

PROGRAMMABLE PARAMETER DETAILS

PARAMETER	PARAMETER DETAIL	APPLIES TO
-----------	------------------	------------

Excessive Reflected Power Shut-Off Delay	Specifies the how long the Excessive Reflected Power feature is held inactive after the RF output is enabled.	All
--	---	-----

XRP DELAY 5S
 Value range: 0 to 30 Seconds
 Factory default setting: 5S

Once the delay times-out, reflected power is continually compared against the XRP THRESH parameter value. The XRP DELAY parameter allows time for the system/process to attain a stable operating point before the Excessive Reflected Power feature is activated.

Related Parameters:
 Excessive Reflected Power Shut-Off

Power Control Gain	Digital Control Loop Gain – Power Control Modes. Controls how fast the digital control loop reacts to changes in the unit's RF output.	All
--------------------	--	-----

POWER CONT GAIN 100%
 Value Range: 0% to 800%, 1% Increments
 Factory default setting: 100%

Setting the gain value to less than 100% will result in a loss of power setpoint accuracy, but may help to reduce plasma/process noise and arcing issues. This parameter rarely requires adjustment from the factory default value.

Power Control Gain and Arc Suppression:
 When used in conjunction with the Arc Suppression feature, this parameter controls how fast the output power returns to normal after arcing stops. When using the Arc Suppression feature, the Power Control Gain parameter value should be set as low as possible, but not so low that it takes too long for the unit's output to reach its setpoint. If the Power Control Gain parameter value is too high, the unit's output may increase too quickly after suppressing an arc and re-establish arcing. The appropriate Power Control Gain parameter value must be empirically established.

Related Parameters:
 Arc Suppression

PROGRAMMABLE PARAMETER DETAILS		
PARAMETER	PARAMETER DETAIL	APPLIES TO

DC Voltage Control Gain	Digital Control Loop Gain – Voltage Control Modes. Controls how fast the digital control loop reacts to changes in the unit’s RF output. DCV CONT GAIN 100% Value Range: 0% to 100%, 1% Increments Factory default setting: 100%	All
-------------------------	---	-----

Setting the gain value to less than 100% will result in a loss of voltage setpoint accuracy but may help to reduce plasma/process noise and arcing issues. This parameter rarely requires adjustment from the factory default value.

DC Control Gain and Arc Suppression:

When used in conjunction with the Arc Suppression feature, this parameter controls how fast the output power returns to normal after arcing stops. When using the Arc Suppression feature, the DC Voltage Control Gain parameter value should be set as low as possible, but not so low that it takes too long for the unit’s output to reach its setpoint. If the DC Voltage Control Gain parameter value is too high, the unit’s output may increase too quickly after suppressing an arc and re-establish arcing. The appropriate DC Voltage Control Gain parameter value must be empirically established.

Factory default setting is 100%

Related Parameters:

Arc Suppression

Matching Network Preset Mode:	Enables or disables the Matching Network Preset feature and configures the behavior of the analog interface connector RFENABLED* signal (pin 8) when the Matching Network Preset feature is enabled.	All
-------------------------------	--	-----

Operational Note:

This feature is designed for use with an externally connected Seren IPS Inc. MC2 matching network controller and AT-Series automatic matching networks. The MC2 controller, AT-Series matching networks, and interface cabling are not supplied with the RF Power Supply and must be purchased separately.

Related Parameters:

Load Capacitor Preset Position
 Tune Capacitor Preset Position

Factory default setting: DISABLE MATCH PRESET

PROGRAMMABLE PARAMETER DETAILS		
PARAMETER	PARAMETER DETAIL	APPLIES TO
MATCH PRE INV ON	<p>When the RF output is disabled, the matching network preset position voltages are present on the analog interface connector's FWD MON and REFP MON signal pins.</p> <p>Analog interface connector RFENABLED* signal (pin 8) outputs a TTL logic high (1) state when the RF output is enabled and the reflected power threshold alarm has not been exceeded.</p> <p>Analog interface connector RFENABLED* signal (pin 8) outputs a TTL logic low (0) state when the RF output is disabled or when the reflected power threshold alarm has been exceeded.</p>	All
MATCH PRESET ON	<p>When the RF output is disabled, the matching network preset position voltages are present on the analog interface connector's FWD MON and REFP MON signal pins.</p> <p>Analog interface connector RFENABLED* signal (pin 8) outputs a TTL logic low (0) state when the RF output is enabled and the reflected power threshold alarm has not been exceeded.</p> <p>Analog interface connector RFENABLED* signal (pin 8) outputs a TTL logic high (1) state when the RF output is disabled or when the reflected power threshold alarm has been exceeded.</p>	All
MATCH PRESET OFF	Disables the Matching Network Preset feature.	All
Load Capacitor Preset Position:	<p>Sets the Load Capacitor preset position voltage output for an external matching network. Adjustable from 0% (0.0VDC output) to 100% (+5.0VDC), in 1% (50mV) increments.</p> <p>With Matching Network Preset Mode enabled and the RF output disabled, the Load Capacitor preset position voltage (0 to +5.0VDC) is present at the analog interface connector's REFP MON (reflected power monitor) signal (pin 11).</p> <p><u>Operational Note:</u> This feature designed for use with Seren IPS Inc. MC2 matching network controller and AT-Series automatic matching networks.</p> <p>Factory default setting: 50%</p> <p><u>Related Parameters:</u> Matching Network Preset Mode</p> <p><u>Related Serial Command:</u> MPL, LPS</p>	All

PROGRAMMABLE PARAMETER DETAILS

PARAMETER	PARAMETER DETAIL	APPLIES TO
Tune Capacitor Preset Position:	<p>Sets the Tune Capacitor preset position voltage output for an external matching network. Adjustable from 0% (0.0VDC output) to 100% (+5.0VDC), in 1% (50mV) increments.</p> <p>With Matching Network Preset Mode enabled and the RF output disabled, the Tune Capacitor preset position voltage (0 to +5.0VDC) is present at the analog interface connector's FWD MON (forward power monitor) signal (pin 10).</p> <p><u>Operational Note:</u> This feature designed for use with the Seren IPS Inc. MC2 matching network controller and AT-Series automatic matching networks.</p> <p>Factory default setting: 50%</p> <p><u>Related Parameters:</u> Matching Network Preset Mode</p> <p><u>Related Serial Command:</u> MPT, TPS</p>	All
Variable Frequency Tuning Enable/Disable:	<p>Enables or disables the Variable Frequency Tuning feature. When enabled, the Variable Frequency Tuning feature monitors the reflected power and automatically adjusts the RF output frequency to minimize the reflected power. Various configurable parameters allow the operator to tailor the Variable Frequency Tuning algorithm's performance to the operator's system.</p> <p><u>Operational Note:</u> When the Variable Frequency Tuning feature is enabled, the Variable Frequency Tuning feature <i>and</i> the VFT Strike Frequency override the programming menu's operating frequency setting.</p> <p>Factory default setting: FREQ TUNE OFF</p> <p><u>Related Parameters:</u> Coarse Tuning Trip Ratio Fine Tuning Trip Level Coarse Frequency Tuning Step Fine Frequency Tuning Step Strike Frequency Maximum Allowable Frequency for Variable Frequency Tuning Minimum Allowable Frequency for Variable Frequency Tuning Variable Frequency Tuning Feedback Mode</p> <p><u>Related Serial Commands:</u> VX, FX</p>	Units configured with adjustable frequency

PROGRAMMABLE PARAMETER DETAILS

PARAMETER	PARAMETER DETAIL	APPLIES TO
Coarse Tuning Trip Ratio:	<p>A ratio of Reflected Power to Forward Power (100)(Reflected Power)/(Forward Power), XXX, where XXX is a user-configurable value.</p> <p>The Coarse Tuning Trip Ratio is a trigger used to switch between the coarse frequency stepping and the fine frequency stepping of the Variable Frequency Tuning (VFT) feature. Coarse frequency stepping is active when the reflected power to forward power ratio is greater than the VFT Coarse Tuning Trip Ratio setting. Fine frequency stepping is active when the reflected power to forward power ratio is equal to or less than the VFT Coarse Tuning Trip Ratio setting. Range: 1 to 100.</p> <p>Factory default ratio setting: 10</p> <p><u>Related Parameters:</u> Variable Frequency Tuning Enable/Disable Fine Tuning Trip Level Coarse Frequency Tuning Step Fine Frequency Tuning Step Strike Frequency Maximum Allowable Frequency for Variable Frequency Tuning Minimum Allowable Frequency for Variable Frequency Tuning Variable Frequency Tuning Feedback Mode</p> <p><u>Related Serial Command:</u> CR</p>	Units configured with adjustable frequency

Fine Tuning Trip Level:	<p>If reflected power level is less than or equal to the Fine Tuning Trip Level, the Variable Frequency Tuning feature stops attempting to match to the load (minimize reflected power). If reflected power is greater than the Fine Tuning Trip Level, the Variable Frequency Tuning feature adjusts the RF output frequency to minimize reflected power. Range: 1 Watt to 99 Watts.</p> <p>Factory default setting: 2 Watts.</p> <p><u>Related Parameters:</u> Variable Frequency Tuning Enable/Disable Coarse Tuning Trip Level Coarse Frequency Tuning Step, Fine Frequency Tuning Step Strike Frequency Maximum Allowable Frequency for Variable Frequency Tuning Minimum Allowable Frequency for Variable Frequency Tuning Variable Frequency Tuning Feedback Mode</p> <p><u>Related Serial Command:</u> FT</p>	Units configured with adjustable frequency
-------------------------	---	--

PROGRAMMABLE PARAMETER DETAILS

PARAMETER	PARAMETER DETAIL	APPLIES TO
-----------	------------------	------------

Coarse Frequency Tuning Step:	When the Reflected Power to Forward Power ratio is greater than the Coarse Tuning Trip Ratio, the Variable Frequency Tuning feature increments or decrements the RF output frequency by the Coarse Frequency Tuning Step value, attempting to match to the load (minimize reflected power).	Units configured with adjustable frequency
-------------------------------	---	--

The Coarse Frequency Tuning Step value is configurable, from 1 Hz 10,000 Hz in 1 Hz increments.

Factory default step setting: 3000 Hz.

Related Parameters:

- Variable Frequency Tuning Enable/Disable
- Coarse Tuning Trip level
- Fine Tuning Trip Level
- Fine Frequency Tuning Step
- Strike Frequency
- Maximum Allowable Frequency for Variable Frequency Tuning
- Minimum Allowable Frequency for Variable Frequency Tuning
- Variable Frequency Tuning Feedback Mode

Related Serial Command: CF

Fine Frequency Tuning Step:	When the Reflected Power to Forward Power ratio is less than or equal to the Coarse Tuning Trip Ratio, the Variable Frequency Tuning feature increments or decrements the RF output frequency by the Fine Frequency Tuning Step value, attempting to match to the load (minimize reflected power).	Units configured with adjustable frequency
-----------------------------	--	--

The Fine Frequency Tuning Step value is configurable, from 1 Hz 10,000 Hz in 1 Hz increments.

Factory default step setting: 1000 Hz.

Related Parameters:

- Variable Frequency Tuning Enable/Disable
- Coarse Tuning Trip Level
- Fine Tuning Trip Level
- Coarse Frequency Tuning Step
- Strike Frequency
- Maximum Allowable Frequency for Variable Frequency Tuning
- Minimum Allowable Frequency for Variable Frequency Tuning
- Variable Frequency Tuning Feedback Mode

Related Serial Command: FF

PROGRAMMABLE PARAMETER DETAILS

PARAMETER	PARAMETER DETAIL	APPLIES TO
Strike Frequency:	<p>With Variable Frequency Enabled, the unit's output frequency defaults to the Strike Frequency setting when the RF output is enabled.</p> <p>If reflected power is greater than the Fine Tuning Trip Level, the Variable Frequency Tuning feature will automatically adjust the RF output frequency in an attempt to match the load (minimize reflected power). The Strike Frequency value must be between the Minimum Allowable Frequency and the Maximum Allowable Frequency values.</p> <p><u>Operational Note:</u> When the Variable Frequency Tuning feature is enabled, the Variable Frequency Tuning feature <i>and</i> the Strike Frequency override the programming menu's operating frequency setting.</p> <p>Strike frequency is configurable in 1 KHz increments.</p> <p><u>Related Parameters:</u> Variable Frequency Tuning Enable/Disable Coarse Tuning Trip Level, Fine Tuning Trip Level Coarse Frequency Tuning Step, Fine Frequency Tuning Step Maximum Allowable Frequency for Variable Frequency Tuning Minimum Allowable Frequency for Variable Frequency Tuning Variable Frequency Tuning Feedback Mode</p> <p><u>Related Serial Command:</u> SF</p>	Units configured with adjustable frequency
Maximum Allowable Frequency for Variable Frequency Tuning:	<p>The Maximum Allowable Frequency limits the highest frequency the Variable Frequency Tuning feature may use while attempting to match the load.</p> <p>The Maximum Allowable Frequency is configurable in 1 KHz increments.</p> <p><u>Related Parameters:</u> Variable Frequency Tuning Enable/Disable Coarse Tuning Trip Level Fine Tuning Trip Level Coarse Frequency Tuning Step Fine Frequency Tuning Step Strike Frequency Minimum Allowable Frequency for Variable Frequency Tuning Variable Frequency Tuning Feedback Mode</p> <p><u>Related Serial Command:</u> MAXVF</p>	Units configured with adjustable frequency

PROGRAMMABLE PARAMETER DETAILS		
PARAMETER	PARAMETER DETAIL	APPLIES TO
Minimum Allowable Frequency for Variable Frequency Tuning:	<p>The Minimum Allowable Frequency limits the lowest frequency the Variable Frequency Tuning feature may use while attempting to match the load.</p> <p>The Minimum Allowable Frequency is configurable in 1 KHz increments.</p> <p><u>Related Parameters:</u> Variable Frequency Tuning Enable/Disable Coarse Tuning Trip Level Fine Tuning Trip Level Coarse Frequency Tuning Step Fine Frequency Tuning Step Strike Frequency Maximum Allowable Frequency for Variable Frequency Tuning Variable Frequency Tuning Feedback Mode</p> <p><u>Related Serial Command:</u> MINVF</p>	Units configured with adjustable frequency
Variable Frequency Tuning Feedback Mode	<p>Selects the method of feedback for the Variable Frequency Tuning feature.</p> <p><u>Related Parameters:</u> Variable Frequency Tuning Enable/Disable Factory Default setting: REFL TUNE MODE</p>	Units configured with adjustable frequency
REFL TUNE MODE	<p>Uses the RF Power Supply's internal reflected power sensor as the feedback source for Variable Frequency Tuning.</p>	Units configured with adjustable frequency
PHASE TUNE MODE +	<p>Uses a voltage signal from an external phase detector to control Variable Frequency Tuning feature.</p> <p>The external phase detector's output is applied to the Analog Interface connector's PHASE input signal. When the PHASE signal is 0.00VDC, the RF Power Supply assumes reflected power is at minimum and stops the tuning process.</p> <p><u>Operational Note:</u> Output frequency increases with a positive (+) polarity input signal.</p>	Units configured with adjustable frequency
PHASE TUNE MODE -	<p>Uses a voltage signal from an external phase detector to control Variable Frequency Tuning feature.</p> <p>The external phase detector's output is applied to the Analog Interface connector's PHASE input signal. When the PHASE signal is 0.00VDC, the RF Power Supply assumes reflected power is at minimum and stops the tuning process.</p> <p><u>Operational Note:</u> Output frequency increases with a negative (-) polarity input signal.</p>	Units configured with adjustable frequency

PROGRAMMABLE PARAMETER DETAILS

PARAMETER	PARAMETER DETAIL	APPLIES TO
------------------	-------------------------	-------------------

<p>Communications Link Status Watchdog Timer</p>	<p>Setting the LINK STATUS parameter to ON enables a watchdog timer function for the communications link (RS-232/422/485). Periodic polling of the RF Power Supply's status by the user's system, using the serial interface "Q" command or issuing any other serial command, resets the watchdog timer. If the watchdog timer expires before a command is received, the RF output is disabled; the Link Status flag is set to "fault" (see serial command "Q"). If the watchdog timer expires while the unit's control source is set to SERIAL, the unit's control source is set to PANEL.</p> <p>Issuing a "Q" command to the RF Power Supply after the watchdog timer has expired returns the status string, with the Link Status flag set to "fault"</p> <p>Issuing the "SERIAL" or "****" command clears the Links Status flag and polling of the RF Power Supply's status must resume or the watchdog timer will expire.</p> <p><u>Operational Notes:</u></p> <ol style="list-style-type: none"> 1. The polling period <u>must</u> be less than the value of the Communication s Link Status Time. 2. Setting Link Status to ON allows viewing and setting of the Link Status Time parameter. 3. If the unit is operated in Panel or Analog control source and the serial interface is not used, the watchdog timer can be used as an RF-ON time limit. <p><u>Related Parameters:</u> Communications Link Status Time-Out</p> <p>Factory default setting: LINK STATUS OFF</p>	<p>All</p>
--	--	------------

<p>Communications Link Status Time-Out</p>	<p>The communications LINK TIMEOUT value sets the longest time the unit may operate without receiving a serial command. Configurable from 0 seconds to 3600 seconds in 1-second increments.</p> <p><u>Related Parameters:</u> Communication Link Status Watchdog Timer</p> <p>Factory default setting: 3S</p>	<p>All</p>
--	---	------------

PROGRAMMABLE PARAMETER DETAILS		
PARAMETER	PARAMETER DETAIL	APPLIES TO

Display Last RF-OFF Event	Displays the last event to disable/turn off the RF output, in the format:	All
---------------------------	---	-----

LAST RF-OFF: XXX

Where XXX indicates the RF-OFF event.

" "	(Blank) Unknown reason or no RF-OFF event yet
ANA	Analog Interface
BAL	Imbalance in Power Amplifier Currents
CBL	Cable Interlock
DCV	Power supply DC Voltage out of range
DN	DeviceNet Command
DN	DeviceNet Disconnect
DN?	DeviceNet Card Communication Timeout
EXT	External Interlock
HDW	Hardware Problem
IMP	Excessive Impedance (XIMP Function)
LNK	Communication link timeout
PAC	One or more Power Amplifier Currents too high
PB	Profibus Command
PB!	Profibus Disconnect
PB?	Profibus Card Communication Timeout
PMD	Mode Change from Front Panel
PNL	Front panel RF On/Off button
SER	Serial Interface (RS-232 / RS-485)
SMD	Mode Change from serial port
TMP	Temperature too high
WTR	Coolant flow (water-cooled units only)
XRP	Excessive Reflected Power
ZRV	Low RF Voltage after timeout (XRFV function)

Related Serial Command: QOFF

PROGRAMMABLE PARAMETER DETAILS

PARAMETER	PARAMETER DETAIL	APPLIES TO
Save Configuration to Flash Memory	Copies all configuration data to the RF Power Supply's internal flash memory.	All

Analog Interface Operation

Basic Analog Interface operation is discussed in this section. Refer to the Rear Panel Controls and Connections and the Typical Interface Connections sections for detailed analog interface operation and connection information.



Connect the RF Power Supply's RF output to a 50-Ohm resistive load, Impedance Matching network, processing system or other suitable load capable of handling the unit's full rated power output *before* enabling AC mains Power.

1. Make control connections to the rear panel ANALOG INTERFACE connector.
2. Press the front panel POWER button (item 10) to enable mains power – the front panel display will illuminate and momentarily display the startup message.
3. Select ANALOG control mode.

Note: The ANALOG control mode only needs to be selected once. The RF Power Supply will retain the selected control mode during a power-off/power-on cycle.

- a. Press the PGM button (Item 1) once.
 - b. Press the DOWN button (item 2) or the UP button (item 3) until line 3 of the display shows the current control source (PANEL CONTROL, ANALOG CONTROL, or SERIAL CONTROL).
 - c. Press the VALUE UP button (item 5) or the VALUE DOWN button (item 6) until ANALOG CONTROL is displayed on line 3.
 - d. Press the ENT button (item 5) to save the selection.
 - e. Press the RUN button (item 1) to exit the programming menu.
4. Select the desired leveling mode “Power” or “Voltage”.

Apply an open circuit or TTL “high” signal to Analog Interface Connector pin 4 to select the power supply's internal power sensor for power regulation. A contact closure between Analog Interface Connector pin 4 and pin 16 or a TTL “low” signal applied to pin 4 selects forward power regulation based on an external feedback signal (FEEDBACK signal – Analog Interface Connector pin 12).

5. Apply the desired setpoint voltage to the SETPOINT signal (Analog Interface Connector pin 13) and SETRET signal (Analog Interface Connector pin 25).
6. Enable the Analog Interface Connector's external interlock (INTERLOCK) circuit. Connect Analog Interface connector pin 2 to pin 15 or apply a TTL logic “low” signal to pin 2.
7. Enable the Analog Interface Connector's RF On (RFON*) circuit. Connect Analog Interface Connector pin 3 to pin 16 or apply a TTL logic “low” signal to pin 3.



Note: the RFON* signal is edge triggered. A transition from a TTL “high” to TTL “low” logic state must occur to enable the RF output. This prevents accidental enabling of the RF output when the RF power supply is powered-up in the ANALOG control mode or when the external interlock (INTERLOCK) is re-established after an external system interlock event.

8. Adjust the setpoint voltage as required.
9. Disable the RF Output. Open the connection between Analog Interface Connector pin 3 to pin 16 or apply a TTL logic “High” signal to pin 2.

Serial Interface Operation

Basic Serial Interface operation is discussed in this section. Refer to the [Rear Panel Controls and Connections](#) section for serial interface connection details. Serial commands are detailed in the [Serial Commands](#) Section.

The serial interface communications protocol is selectable; RS-232, RS-485 4-wire, or RS-485 2-wire, MODBUS 2-Wire, MODBUS 4-Wire. The baud rate is selectable, 2400, 4800, 9600, 19200, 38400, 57600, or 115200 Baud (see below). The factory default baud rate is 19,200 baud. The factory default serial address is 99 (RS422/485/MODBUS protocols).



Connect the unit's RF output to a 50-Ohm resistive load, Impedance Matching network, processing system or other suitable load capable of handling the unit's full rated power output before enabling AC mains Power.

1. Connect a terminal, personal computer, or system controller to the rear panel SERIAL interface connector. NOTE: the Serial Interface connector uses a non-standard pin-list. Refer to the [Rear Panel Controls and Connections](#) section for connection details.
2. Press the front panel POWER button (item 10) to enable mains power – the front panel display will illuminate and momentarily display the startup message.
3. Select SERIAL control mode.

Note: The SERIAL control mode only needs to be selected once. The RF power supply will retain the selected control mode during a power-off/power-on cycle.

- a. Press the PGM button (Item 1) once.
 - b. Press the DOWN button (item 2) or the UP button (item 3) until line 3 of the display shows the current control source (PANEL CONTROL, ANALOG CONTROL, or SERIAL CONTROL).
 - c. Press the VALUE UP button (item 5) or the VALUE DOWN button (item 6) until SERIAL CONTROL is displayed on line 3.
 - d. Press the ENT button (item 5) to save the selection.
 - e. Remain in the programming environment, ***do not*** press the RUN button.
4. Select the SERIAL COMMUNICATIONS PROTOCOL:
Serial control must be selected before attempting to select the communications protocol. If the unit is set for PANEL or ANALOG control mode, the communications protocol selection will not appear in the programming menu.

Note: The serial communications protocol only needs to be selected once. The RF power supply will retain the selected serial communications protocol during a power-off/power-on cycle.

- a. Press the DOWN button (item 2) or the UP button (item 3) until line 3 of the display shows the current serial communications protocol - RS232, RS422, RS485-4 (4 wire), RS485-2 (2 wire), MODBUS 2W (2 wire) or MODBUS 4W (4 wire).
- b. Press the VALUE UP button (item 5) or the VALUE DOWN button (item 6) until the desired serial protocol is displayed on line 3
- c. Press the ENT button (item 5) to save the selection.

5. Set the unit's SERIAL ADDRESS

(required for RS-422, RS-485 and MODBUS protocols):

Serial Control *and* RS422, RS485, or MODBUS protocol must be selected before attempting to set the unit's address. If the unit is set for PANEL or ANALOG control mode, or RS-232 communications protocol, the address selection will not appear in the programming menu.

Note: The serial address only needs to be set once. The RF power supply will retain the selected address during a power-off/power-on cycle.

For single user (single drop) RS422 or RS485 communications, set the unit's address to "99" (factory default).

- a. Press the DOWN button (item 2) or the UP button (item 3) until line 3 of the display shows the address (ADDRESS # XX).
- b. Press the VALUE UP button (item 5) or the VALUE DOWN button (item 6) until the desired address (0-99) is displayed on line 3
- c. Press the ENT button (item 5) to save the selection.

6. Select the BAUD rate:

Serial control must be selected before attempting to select the baud rate. If the unit is set for PANEL or ANALOG control mode, the baud rate selection will not appear in the programming menu.

Note: The BAUD rate only needs to be selected once. The RF power supply will retain the selected BAUD rate during a power-off/power-on cycle.

- a. Press the DOWN button (item 2) or the UP button (item 3) until line 3 of the display shows the current baud rate.
- b. Press the VALUE UP button (item 5) or the VALUE DOWN button (item 6) until the desired baud rate is displayed on line 3
- c. Press the ENT button (item 5) to save the selection.
- d. Press the RUN button (item 5) to exit the programming menu.

7. Send the desired serial command to the RF Power Supply.

Serial Communications: RS232, RS422, RS485 Protocols

Serial communication protocol details:

- The underscore character (_) indicates a space, terminators are specified as carriage return <cr>.
- Unless otherwise specified, with ECHO mode set to *disabled*, the RF Power Supply responds with <cr>” for an accepted command, or “N<cr>” for an invalid command.
- Unless otherwise specified, with ECHO mode set to *enabled*, the RF Power Supply echoes (transmits) any character it receives as soon as the character is received. A command is checked for validity after the carriage return character <cr> is received. Once the <cr> is received, the response to the command is the same whether ECHO mode is enabled or disabled.
- The RF Power Supply process ASCII characters with values of 32 through 127 (hex 20 through 7F), and the carriage return character (13 or hex 0D). All Other characters are ignored and are not echoed.
- RS-485 (2-wire) communications protocol does not support ECHO mode (set to *disabled* by software default).
- RS-422 communications protocol mode is listen-only.
- The prompt character is <cr>
- Baud rate is configurable, but the parity bits, data bits, stop bits, and handshaking are fixed at: Parity: None, Data Bits: 8, Stop Bits: 1, Handshaking: None.

Note: All RLX01-Series RF Power Supply serial commands are shown in this manual. Some serial commands are not applicable to all models or model configurations. Refer to the Serial Command Details section for application information.

Note: The serial commands described in this section apply to RS-232, RS-422, and RS-485 protocols only. MODBUS operation is described in the Serial Communications: MODBUS Protocol section of this manual.

Serial Command Reference Chart

- The underscore character (_) indicates a space
- Prompt character is the carriage return (<cr>) symbol
- The letter “X” indicates a variable character.
- ”XXX” indicates a numeric value.
- No padding or leading zeros are required when sending a value as part of a command
- Response to all invalid commands: “N<cr>”
- Responses shown in the chart below assume ECHO mode is *disabled*.

SERIAL COMMAND REFERENCE CHART			
TO	SEND	DESCRIPTION/COMMENT	Applies To
Assert SERIAL control	***<cr> or SERIAL<cr>	Sets the serial interface as the control source. Response: <cr>	All
Enable character ECHO mode	ECHO<cr>	Characters sent to the unit are sent back (echoed) to the source. Response: <cr>	All
Disable character ECHO mode	NOECHO<cr>	Suppresses character echo. Response: <cr>	All
Assert ANALOG control	ANALOG<cr>	Sets the analog interface as the control source. Response: <cr>	All
Assert PANEL control	PANEL<cr>	Sets the front panel as the control source. Response: <cr>	All
Set the Operating Frequency	XXXXX_FQ<cr>	XXX is the operating frequency in KHz, 1 KHz increments. Response: <cr>	Units configured with adjustable frequency
Query the Operating Frequency	QFRQ<cr>	Returns the RF output frequency, in KHz, 1KHz increments. 3 to 5 digits, terminated with <cr>. Response: XXXXX<cr>	All
Set the Exciter Mode to MASTER	MST<cr>	Selects the RF Power Supply's internal frequency source. Response: <cr>	All
Set the Exciter Mode to SLAVE	SLV<cr>	Selects the rear panel CEX IN connector as the frequency source. Response: <cr>	All

SERIAL COMMAND REFERENCE CHART			
TO	SEND	DESCRIPTION/COMMENT	Applies To
Select FORWARD POWER leveling	DL<cr>	Regulates the RF output level based solely on forward power. Response: <cr>	All
Select LOAD POWER leveling	EL<cr>	Regulates the RF output power based on the net power delivered to the load. (forward power – reflected power = net power) Response: <cr>	All
Select POWER CONTROL mode	IR<cr>	Sets the unit's internal power sensor as the feedback source for regulating the RF output level. Response: <cr>	All
Select VOLTAGE CONTROL mode	DR<cr>	Sets the Analog Interface connector FEEDBACK signal as the feedback source for regulating the RF output level. Response: <cr>	All
Select High Range power mode	HR<cr>	Sets output power range to High Mode (0 to 100% of rated power) Response: <cr>	Units supporting Low Range operation
Select Low Range power mode	LR<cr>	Sets output power range to Low Mode (typically 0 to 10% of rated power) Response: <cr>	Units supporting Low Range operation
Set the Power Setpoint	XXXXX_W<cr>	High Range: XXXX is the desired power output, in Watts.	All
	XXX.X_W<cr>	Low Range: XXX.X is the desired power output, in Watts (decimal point required) Response: <cr>	Units supporting Low Range operation
Set the Power Setpoint to 0 Watts <i>and disable</i> RF output	WS<cr>	Sets power setpoint to Zero (0) Watts and Disable the RF output Response: <cr>	All
Set the Power Setpoint <i>and enable</i> RF Output	XXXXX_WG<cr>	High Range: XXXX is the desired power output, in Watts.	All
	XXX.X_WG<cr>	Low Range: XXX.X is the desired power output, in Watts (decimal point required) Response: <prompt><cr>	Units supporting Low Range operation

SERIAL COMMAND REFERENCE CHART			
TO	SEND	DESCRIPTION/COMMENT	Applies To
Set the Voltage Setpoint	XXXX_V<cr>	XXXX is the desired output, in Volts. Response: <cr>	All
Set the Pulse duty cycle	XXX_D<cr>	XXX is the pulse duty cycle, 1 to 100%, in 1 % increments. Response: <cr>	All
Set the Pulse Frequency (Pulse Type 0 only)	XXXXX_PR<cr>	XXXXX is the process pulse frequency, in Hertz, in 1Hz increments	See Pulsing section of manual
Set the Pulse high time (Pulse Type 1 only)	XXXX_HT<cr>	XXXX is the pulse high time, in milliseconds. 1mS to 9999mS. Response: <cr>	See Pulsing section of manual
Set the Pulse High Power Setpoint (Pulse Type 1 only)	XXXXX_HP<cr>	XXXX is the pulse high power setpoint, in Watts. Response: <cr>	See Pulsing section of manual
Set the Process Pulse Low Power Setpoint (Pulse Type 1 only)	XXXXX_LP<cr>	XXXX is the pulse low power setpoint, in Watts. Response: <cr>	See Pulsing section of manual
Enable PULSE mode	+P<cr>	Enables Pulsing Response: <cr>	See Pulsing section of manual
Disable PULSE mode	-P<cr>	Disables Pulsing Response: <cr>	See Pulsing section of manual
Set VFT Coarse Trip Ratio	XXX_CR<cr>	XXX is the ratio: (100) (Reflected Power) / (Forward Power) Range 1 to 100 Response: <cr>	Units configured with adjustable frequency
Set VFT Coarse Frequency Step	XXXXX_CF<cr>	XXXXX is the coarse frequency step, 1 Hz to 10,000 Hz, 1 Hz increments. Response: <cr>	Units configured with adjustable frequency
Set VFT Fine Frequency Step	XXXXX_FF<cr>	XXXXX is the fine frequency step, 1 Hz to 10,000 Hz, 1 Hz increments. Response: <cr>	Units configured with adjustable frequency
Set VFT Fine Trip Level	XXX_FT<cr>	XXX is the reflected power level, in Watts, where VFT stops attempting to match the load. Range: 1 to 100 Watts, 1-Watt increments. Response: <cr>	Units configured with adjustable frequency

SERIAL COMMAND REFERENCE CHART			
TO	SEND	DESCRIPTION/COMMENT	Applies To
Set Maximum VFT Frequency	XXX_MAXVF<cr> >	XXX is the maximum frequency (in KHz) the VFT feature may use. 1 KHz increments. Response: <cr>	Units configured with adjustable frequency
Set Minimum VFT frequency	XXX_MINVF<cr>	XXX is the minimum frequency (in KHz) the VFT feature may use. 1 KHz increments. Response: <cr>	Units configured with adjustable frequency
Set VFT Strike Frequency	XXX_SF<cr>	XXX is the desired strike frequency, in KHz.. 1 KHz increments. Response: <cr>	Units configured with adjustable frequency
Enable Variable Frequency Tuning (VFT)	VX<cr>	Enables VFT feature. Response: <cr>	Units configured with adjustable frequency
Disable Variable Frequency Tuning (VFT)	FX<cr>	Disables VFT feature. Response: <cr>	Units configured with adjustable frequency
Enable RF Output	G<cr>	Enable the RF Output Response: <cr>	All
Disable RF Output	S<cr>	Disable the RF Output Response: <cr>	All
Enable RF Output Ramping	EU<cr>	Enables RF output Ramp-Up and Ramp-Down Response: <cr>	All
Disable RF Output Ramping	DU<cr>	Disables RF output Ramp-Up and Ramp-Down Response: <cr>	All
Set RF output Ramp-Down time interval	XXXX_DN<cr>	XXXX is the desired ramp down time interval, 0 to 9999 seconds, in 1-second increments.	All
Set RF output Ramp-Up time interval	XXXX_UP<cr>	XXXX is the desired ramp up time interval, 0 to 9999 seconds, in 1-second increments.	All

SERIAL COMMAND REFERENCE CHART			
TO	SEND	DESCRIPTION/COMMENT	Applies To
Query the Forward Power output	W?<cr>	Returns forward power output, in Watts. Units below 10,000 Watts: 4 digits, padded with leading spaces. Units 10,000 Watts or greater: 5 digits, padded with leading spaces. High Range: Value in 1-Watt increments Low Range: Value in 0.1-Watt Increments Response: XXXX<cr>	All
Query Reflected Power	R?<cr>	Returns reflected power, in Watts. 4 digits padded with leading spaces. High Range: Value in 1-Watt increments Low Range: Value in 0.1-Watt Increments Response: XXXX<cr>	All
Query the DC Bias Voltage	0?<cr>	Returns the developed DC Bias Voltage, with scaling and probe attenuation factors applied. Response: XXXX<cr> (Negative polarity is assumed) Note: R/LX01 series RF Power supplies have only one external feedback channel, therefore, this command is identical to the "V?" command.	All
Query the Control Voltage	V?<cr>	Returns the Control Voltage, with scaling and probe attenuation factors applied. Response: XXXX<cr> (Negative polarity is assumed) Note: R/LX01 series RF Power supplies have only one external feedback channel, therefore, this command is identical to the "0?" command.	All
Query Power Leveling Mode	LVL?<cr>	Returns the current power leveling mode: Response: 0<cr> for Forward Power Leveling 1<cr> for Load (net) Power Leveling.	All
Query Status (Long From)	Q<cr>	Returns status in the form of a mapped string, terminated with <cr>. See Serial Command Details section for string mapping information.	All

SERIAL COMMAND REFERENCE CHART			
TO	SEND	DESCRIPTION/COMMENT	Applies To
Query Status (Short Form)	R<cr>	Returns status in the form of a mapped string, terminated with <cr>. See Serial Command Details section for string mapping information.	All
Query Status (Fixed Format)	QFF<cr>	Returns setpoint, forward power, reflected power, and rated power in a fixed-length string, terminated with <cr>. See Serial Command Details section for string mapping.	All
Query Maximum Power	M?<cr>	Returns the absolute maximum forward power of the unit, in Watts. Units below 10,000 Watts: 4 digits, padded with leading spaces, 1-Watt increments. Units 10,000 Watts or greater: 5 digits, 1-Watt increments. Response: XXXX<cr>	All
Select CURRENT CONTROL mode	CURR<cr>	Sets the RF Power Supply to regulate the RF output using the analog interface FEEDBACK signal, assuming the feedback voltage is proportional to current (typically 0.01VDC = 0.01A) Response: <cr>	Units configured for current control
Set the CURRENT setpoint	XX.XX_AMPS<cr> >	XX.XX is the desired current, in 0.01 Amp increments. The decimal point is optional, but if it is omitted, the value is assumed to be in 0.01 Amp increments. Response: <cr>	Units configured for current control
Query the CURRENT output	QAMP<cr>	Returns the Current output as measured from the analog interface FEEDBACK signal voltage. The value is reported in Amps with 2 decimal places, 0.01 Amp increments. Response XX.XX<cr>	Units configured for current control
Query the Setpoint	QSET<cr>	Returns the setpoint value. Resolution depends on the regulation source and range. Power Control, High Range: 1 Watt Power Control, Low Range: 0.1 Watt Voltage Control: 1 Volt Current Control: 0.01A Response: XXXX<cr> (no decimal point)	All

SERIAL COMMAND REFERENCE CHART			
TO	SEND	DESCRIPTION/COMMENT	Applies To
Query Process Parameters	CGP?<cr>	Returns Process Parameters stored in the RF Power Supply's memory. Response: aaa_bbb_ccc_dd<cr> See Serial Command Details section for response information.	Custom OEM Units
Query Process Start Parameters	CSP?<cr>	Returns Process Start Parameters stored in the RF Power Supply's memory. Response: aaa_bbb_ccc_ddd_eeee<cr> See Serial Command Details section for response information.	Custom OEM Units
Query Power 1 Parameter	P1?<cr>	Returns Power 1 parameter stored in the RF Power Supply's memory. Response: a_b_ccc_ddd_e_f<cr > See Serial Command Details section for response information.	Custom OEM Units
Query Power 2 Parameter	P2?<cr>	Returns Power 2 parameter stored in the RF Power Supply's memory. Response: a_b_ccc_ddd_e_f<cr > See Serial Command Details section for response information.	Custom OEM Units
Query Power 3 Parameter	P3?<cr>	Returns Power 3 parameter stored in the RF Power Supply's memory. Response: a_b_ccc_ddd_e_f<cr > See Serial Command Details section for response information.	Custom OEM Units
Query Power 4 Parameter	P4?<cr>	Returns Power 4 parameter stored in the RF Power Supply's memory. Response: a_b_ccc_ddd_e_f<cr > See Serial Command Details section for response information.	Custom OEM Units
Query Power 5 Parameter	P5?<cr>	Returns Power 5 parameter stored in the RF Power Supply's memory. Response: a_b_ccc_ddd_e_f<cr > See Serial Command Details section for response information.	Custom OEM Units

SERIAL COMMAND REFERENCE CHART			
TO	SEND	DESCRIPTION/COMMENT	Applies To
Query Power 6 Parameter	P6?<cr>	Returns Power 6 parameter stored in the RF Power Supply's memory. Response: a_b_ccc_ddd_e_f<cr > See Serial Command Details section for response information.	Custom OEM Units
Query Reflected Power, Forward Power, and Status with one command	R?W?R<cr>	Returns Reflected Power, Forward Power, and RF Power Supply status as a single string. Response: RRRR_WWWWW_XXXXXXXX<cr>	All
Query Firmware Version	VERS<cr>	Returns the firmware version. Response: XX.XXXX<cr>	All
Query RF Amplifier DC Power Supply Voltage	QDCV<cr>	Diagnostic command. Returns the DC power supply Voltage for the RF power amplifier. Response: XX<cr>	All
Query RF Amplifier power transistor Device Dissipation	QDIS<cr>	Diagnostic command. Returns the Device Dissipation of the RF Amplifier power transistors, in Watts/Device. Response: XXX<cr>	All
Query Total RF Power Amplifier (PA) Current	QPAT<cr>	Diagnostic command. Returns the total (combined) current used by all RF power amplifiers. Response: XXX Where XXX is the total power amplifier current, in Amperes. Resolution is 1A	All
Query Individual RF Power Amplifier Current	QPAx<cr>	Diagnostic command. Returns the current draw of an individual RF power amplifier (PA). Where x is amplifier number (1-8) Response: XX.X Where XX.X is the amplifier current, in Amperes. Resolution is 0.1A	All

SERIAL COMMAND REFERENCE CHART			
TO	SEND	DESCRIPTION/COMMENT	Applies To
Query Internal Temperature	QTMP<cr>	Diagnostic command. Returns the internal temperature of the RF amplifier heatsink, in Degrees Celsius (°C). Response: XX.X<cr>	All
Query the reason for the last RF-OFF	QOFF<cr>	Reports the reason / condition code for the cause of the last RF-OFF event. Response: XXX<cr> Where XXX is a 3-character text string. Refer to the Serial Command Details section for RF-OFF codes.	All

SERIAL COMMAND REFERENCE CHART - MC2 "PASS-THRU" COMMANDS			
TO	SEND	DESCRIPTION/COMMENT	Applies To
Set MC2 Load capacitor to automatic	ALD<cr>	Set MC2 Load capacitor control mode to automatic. Response: <cr>	All
Set MC2 Tune capacitor to automatic	ATN<cr>	Set MC2 Tune capacitor control mode to automatic. Response: <cr>	All
Move Tune and Load Capacitors to preset positions	GOTO<cr>	Instructs MC2 controller to move Tune and Load capacitors to preset positions. Response: <cr>	All
Query MC2 Load Capacitor Preset Position	LPS<cr>	Returns the current Load Capacitor Preset position stored in the MC2's memory. Response: XXX<cr> XXX is the Load Capacitor preset position, 0 to 100, in percent, 1 to 3 digits, in 1% increments	All
Query MC2 Tune Capacitor Preset Position	TPS<cr>	Returns the current Tune Capacitor Preset position stored in the MC2's memory Response: XXX<cr> XXX is the Tune Capacitor preset position, 0 to 100, in percent, 1 to 3 digits, in 1% increments	All

SERIAL COMMAND REFERENCE CHART - MC2 "PASS-THRU" COMMANDS			
TO	SEND	DESCRIPTION/COMMENT	Applies To
Set MC2 Load capacitor to manual	MLD<cr>	Set MC2 Load capacitor control mode to manual. Response: <cr>	All
Set MC2 Tune capacitor to manual	MTN<cr>	Set MC2 Tune capacitor control mode to manual. Response: <cr>	All
Set MC2 Load Capacitor Preset Position	XXX_MPL<cr>	XXX is the desired Load Capacitor preset position, 0 to 100, in percent, in 1% increments Response: <cr>	All
Set MC2 Tune Capacitor Preset Position	XXX_MPT<cr>	XXX is the desired Tune Capacitor preset position, 0 to 100, in percent, in 1% increments Response: <cr>	All
Query MC2 Magnitude Voltage	MAG<cr>	Returns the current Magnitude Error Voltage from MC2 Matching network controller. Response: XXXX<cr> XXXX is the Magnitude Error Voltage, in milli-Volts (mV), 1 to 4 digits.	All
Query MC2 Phase Voltage	PHS<cr>	Returns the current Phase Error Voltage from MC2 Matching network controller. Response: XXXX<cr> XXXX is the Phase Error Voltage, in milli-Volts (mV), 1 to 4 digits.	All

Serial Communications: Serial Command Details, RS232, RS422, and RS485 Protocols

- The underscore character (_) indicates a space, terminators are specified as or carriage return <cr>.
- Unless otherwise specified, with ECHO mode set to *disabled*, the RF Power Supply responds with <cr>” for an accepted command, or “N<cr>” for an invalid command.
- Unless otherwise specified, with ECHO mode set to *enabled*, the RF Power Supply echoes (transmits) any character it receives as soon as the character is received. A command is checked for validity after the carriage return character <cr> is received. Once the <cr> is received, the response to the command is the same whether ECHO mode is enabled or disabled.
- The RF Power Supply process ASCII characters with values of 32 through 127 (hex 20 through 7F), and the carriage return character (13 or hex 0D). All Other characters are ignored and are not echoed.
- RS-485 (2-wire) communications protocol does not support ECHO mode (set to *disabled* by software default).
- RS-422 communications protocol mode is listen-only.
- Baud rate is configurable, but the parity bits, data bits, and stop bits are fixed at: No Parity, 8 Data Bits, and 1 Stop Bit.
- The prompt character is <cr>
- Response to all invalid commands: “N<cr>”
- Responses shown in the chart below assume ECHO mode is *disabled*
- The letter “X” indicates a variable character.
- “XXX” indicates a numeric value.
- No padding or leading zeroes are needed when sending a value as part of a command.

Note: All RLX01-Series RF Power Supply serial commands are shown in this manual. Some serial commands are not applicable to all models or model configurations and are noted in the individual command detail descriptions.

Note: The serial commands described in this section apply to RS-232, RS-422, and RS-485 protocols only. MODBUS operation is described in the Serial Communications: MODBUS Protocol section of this manual.

SERIAL COMMAND DETAILS		
COMMAND	COMMAND DETAIL	APPLIES TO
***	<p>Assert SERIAL control mode.</p> <p>Switches control of the unit to the serial interface. Front panel setpoint and RF ON commands are ignored. Analog Interface Connector signals RFON* and SETPOINT are ignored.</p> <p><u>Operational Notes:</u></p> <ol style="list-style-type: none"> 1. If this command is issued while RF output is enabled and the unit is under Analog or Panel control, the RF output will be disabled. 2. The RF Power Supply powers-up in the last known control state. 3. This command is similar to the SERIAL command <p>Command: ***<cr></p> <p>Response: <cr></p>	All
0?	<p>Query the DC Bias Voltage</p> <p>Responds with the external feedback (or DC Bias) Voltage, with Probe Attenuation and scaling factors applied. R/LX01 series RF Power supplies have only one external feedback channel, therefore, this command is identical to the “V?” command. A negative (-) polarity signal is assumed.</p> <p>Command: 0?</p> <p>Response: XXXX<cr></p>	All
ALD	<p>Sets the MC2 Controller for automatic operation of the “Load” capacitor</p> <p>The “ALD” command is passed thorough the RF Power Supply to the Seren IPS Inc. model MC2 Matching Network Controller. The RF Power Supply does not use or store the information.</p> <p><u>Operational Note:</u></p> <p>Communicating with an MC2 Matching Network Controller via the RF Power Supply requires a serial interface connection from the RF Power Supply to the MC2 matching network controller. Requires serial interface cable assembly 910012XXXX, or serial interface cable assembly 910014XXXX, or custom wiring provided by the user. Consult the factory for assistance.</p> <p>Command: ALD<cr></p> <p>Response: <cr></p>	All
AMPS	<p>Sets the Current Control setpoint.</p> <p>Command: XX.XX_AMPS<cr></p> <p>Where XX.XX is the desired current in Amperes, 0.01 Amp increments. The decimal point is optional, but if it is omitted, the value is assumed to be in 0.01 Amp increments</p> <p>Response: <cr></p>	Units configured for current control

SERIAL COMMAND DETAILS

COMMAND	COMMAND DETAIL	APPLIES TO
ANALOG	<p>Assert ANALOG control</p> <p>Switches control of the unit to the Analog Interface Connector. Power settings and RF ON commands from the front panel or the serial interface are ignored.</p> <p><u>Operational Notes:</u></p> <ol style="list-style-type: none"> 1. The RF Power Supply powers-up in the last known control state. 2. This command should be issued only while the RF output is off (disabled). <p>Command: ANALOG<cr></p> <p>Response: <cr></p>	All
ATN	<p>Sets the MC2 Controller for automatic operation of the “Tune” capacitor</p> <p>The “ATN” command is passed thorough the RF Power Supply to the Seren IPS Inc. model MC2 Matching Network Controller. The RF Power Supply does not use or store the information.</p> <p><u>Operational Note:</u></p> <p>Communicating with an MC2 Matching Network Controller via the RF Power Supply requires a serial interface connection from the RF Power Supply to the MC2 matching network controller. Requires serial interface cable assembly 910012XXXX, or serial interface cable assembly 910014XXXX, or custom wiring provided by the user. Consult the factory for assistance.</p> <p>Command: ATN<cr></p> <p>Response: <cr></p>	All
CR	<p>Set Variable Frequency Tuning Coarse Trip Ratio</p> <p>Command: XXX_CR<cr></p> <p>Where XXX is the ratio: $(100)(\text{Reflected Power})/(\text{Forward Power})$</p> <p>The Coarse Trip Ratio is a trigger used to switch between the coarse frequency stepping and the fine frequency stepping of the Variable Frequency Tuning (VFT) feature. Coarse frequency stepping is active when $(100)(\text{Reflected Power})/(\text{Forward Power})$ is greater than the VFT Coarse ratio setting. Fine frequency stepping is active when $(100)(\text{Reflected Power})/(\text{Forward Power})$ is equal to or less than the Coarse Ratio setting.</p> <p>Range: 1 to 100, increments of 1. Factory Default: 10</p> <p>Response: <cr></p>	Units configured with adjustable frequency
CF	<p>Set Variable Frequency Tuning Coarse Frequency Step</p> <p>Command: XXXXX_CF<cr></p> <p>Where XXXXX is the coarse frequency step, in Hz, 1 to 5 digits, 1 Hz to 10,000 Hz used by the Variable Frequency Tuning feature to match the load.</p> <p>Factory Default is 3000 Hz.</p> <p>Response: <cr></p>	Units configured with adjustable frequency

SERIAL COMMAND DETAILS		
COMMAND	COMMAND DETAIL	APPLIES TO
CGP?	<p>Query Process Parameters</p> <p>Command: CGP?<cr></p> <p>Response: aaa_bbb_ccc_dd<cr></p> <p>Where:</p> <p>“aaa” is the Start Power Parameter</p> <p>“bbb” is the Idle Power Parameter</p> <p>“ccc” is the PBN Start Current Parameter</p> <p>“dd” is the Power/Beam Factor Parameter</p> <p>Note: Process Parameters are stored in the RF Power Supply’s memory and can be viewed or edited via the Programming Menu. The RF Power Supply does nothing with these parameters other than provide storage for them.</p>	Custom OEM Configurations
CSP?	<p>Query Process Start Parameters</p> <p>Command: CSP?<cr></p> <p>Response: aaa_bbb_ccc_ddd_eeee<cr></p> <p>Where:</p> <p>“aaa” is the Start Sense Voltage (Start Sense V)Parameter</p> <p>“bbb” is not implemented and always returns a “0”</p> <p>“ccc” is not implemented and always returns a “0”</p> <p>“ddd” is the Start Detect Current (Start Detect I) Parameter</p> <p>“eeee” is the Start Pulse Voltage (Start Pulse V) Parameter</p> <p>Note: The Process Start Parameters are stored in the RF Power Supply’s memory and can be viewed or edited via the Programming Menu. The RF Power Supply does nothing with the Process Start Parameters other than provide storage for them.</p>	Custom OEM Configurations
CURR	<p>Selects Current Control output regulation mode.</p> <p>Sets the RF Power Supply to regulate the RF output power using the analog interface FEEDBACK signal, assuming the FEEDBACK signal voltage is proportional to current (typically 0.01VDC = 0.01 Amps).</p> <p>Command: CURR<cr></p> <p>Response: <cr></p>	Units configured for current control
D	<p>Set the Process Pulse Duty Cycle</p> <p>Command: XXX_D<cr></p> <p>Where XXX is the process pulse duty cycle, 1% to 100%, in 1% increments. 1 to 3 digits.</p> <p>Response: <cr></p>	All models except R/L301, R101

SERIAL COMMAND DETAILS

COMMAND	COMMAND DETAIL	APPLIES TO
DL	<p>Select FORWARD POWER leveling</p> <p>Configures the RF Power Supply to regulate the RF output so that the forward power output matches the power setpoint (applies while the unit is set for Power Control mode and does not apply to Voltage Control or Current Control modes)</p> <p>Related Commands: W, EL</p> <p>Command: DL<cr></p> <p>Response: <cr></p>	All
DN	<p>Set RF Output Ramp-Down time</p> <p>Specifies the Ramp-Down time interval. When the RF output is disabled (by the front panel, analog interface or the “S” serial command), the RF output power is decreased from the current setpoint to 0 Watts over the specified time interval.</p> <p>Factory default value is 1.</p> <p>Related Commands: UP, DU, EU</p> <p><u>Operational Note:</u> RF output ramping is not available in Voltage Control or Current Control (external feedback) modes.</p> <p>RF output ramping is also configurable via the front panel programming menu.</p> <p>Command: XXXX_DN<cr></p> <p style="padding-left: 20px;">Where XXXX is the Ramp Down time interval in seconds. Range: 0 to 9999 seconds, in 1-second increments, 1 to 4 digits.</p> <p>Response: <cr></p>	All
DR	<p>Select VOLTAGE CONTROL mode</p> <p>Selects the Analog Interface connector’s FEEDBACK signal as the feedback source for regulating the RF output level.</p> <p>Related commands: “V?”, “0?”, and “V”.</p> <p>Command: DR<cr></p> <p>Response: <cr></p>	All
DU	<p>Disable RF Output Ramping</p> <p>Disables RF output Ramp Up <i>and</i> RF output Ramp Down. The “DU” command does not modify the Ramp Up or Ramp Down time interval.</p> <p>Related Commands: DN, UP, EU</p> <p><u>Operational Note:</u> RF output ramping is not available in Voltage Control or Current Control (external feedback) modes.</p> <p>RF output ramping is also configurable via the front panel programming menu.</p> <p>Command: DU<cr></p> <p>Response: <cr></p>	All

COMMAND	COMMAND DETAIL	APPLIES TO
ECHO	<p>Enable ECHO mode</p> <p>Characters sent to the unit are sent back (echoed) to the sending source.</p> <p>Command: ECHO<cr></p> <p>Response: <cr></p>	All
EL	<p>Select LOAD POWER leveling</p> <p>Configures the RF Power Supply to deliver a constant Net Power to the load. Net Power = (Forward Power – Reflected Power). The RF Power Supply regulates its output so that the Net Power matches the power setpoint (applies while the unit is set for Power Control mode and does not apply to Voltage Control or Current Control modes)</p> <p>Related Commands: W, DL</p> <p>Command: EL<cr></p> <p>Response: <cr></p>	All
EU	<p>Enable RF Output Ramping</p> <p>Enables RF output Ramp Up <i>and</i> RF output Ramp Down. The “EU” command does not modify the Ramp Up or Ramp Down time interval.</p> <p>Related Commands: DN, DU, UP</p> <p><u>Operational Note:</u> RF output ramping is not available in Voltage Control or Current Control (external feedback) modes.</p> <p>RF output ramping is also configurable via the front panel programming menu.</p> <p>Command: EU<cr></p> <p>Response: <cr></p>	All
FF	<p>Set Variable Frequency Tuning Fine Frequency Step</p> <p>Command: XXXXX_FF<cr></p> <p>Where XXXXX is the fine frequency steps, in Hz, 1 to 5 digits, 1 Hz to 10,000 Hz, used by the Variable Frequency Tuning feature to match the load (minimize reflected power).</p> <p>Factory Default: 1000 Hz.</p> <p>Response: <cr></p>	Units configured with adjustable frequency
FT	<p>Set Variable Frequency Tuning Fine Trip Level</p> <p>Command: XXX_FT<cr></p> <p>Where XXX is the reflected power level, in Watts, 1 to 3 digits, where Variable Frequency Tuning stops attempting to match to the load by adjusting the RF output frequency.</p> <p>Factory Default: 2 Watts.</p> <p>Response: <cr></p>	Units configured with adjustable frequency

SERIAL COMMAND DETAILS		
COMMAND	COMMAND DETAIL	APPLIES TO
FQ	Set the Operating Frequency Command: XXXXX_FQ<cr> Where XXXXX is the desired operating frequency, in KHz, 1 KHz increments. 3 to 5 digits, depending on model operating frequency. Response: <cr>	Units configured with adjustable frequency
FX	Set Variable Frequency Tuning Feature to Disabled Command: FX<cr> Response: <cr>	Units configured with adjustable frequency.
G	Enable the RF Output Command: G<cr> Response: <cr>	All
GOTO	Instructs the MC2 Controller for to move the Tune and Load capacitors to their preset positions. The “GOTO” command is passed through the RF Power Supply to an externally connected Seren IPS Inc. model MC2 Matching Network Controller. The RF Power Supply does not use or store the information. <u>Operational Note:</u> Communicating with an MC2 Matching Network Controller via the RF Power Supply requires a serial interface connection from the RF Power Supply to the MC2 matching network controller. Requires serial interface cable assembly 910012XXXX, or serial interface cable assembly 910014XXXX, or custom wiring provided by the user. Consult the factory for assistance. Command: GOTO<cr> Response: <cr>	All
HP	Set the Pulse High Power Setpoint <u>Operational Note:</u> Applies to Pulse type 1 only. Command: XXXXX_HP<cr> Where XXXXX is the pulse high power setpoint, in Watts. 1 to 5 digits, 0 Watts to Rated Power (Watts). Response: <cr>	See Pulsing section of manual
HR	Sets the output power range to High Mode. Output power range is 0 to 100% of rated power. Power setpoint, forward power metering, and reflected power metering resolution is 1Watt Command: HR<cr> Response: <cr>	Units supporting Low Range operation

COMMAND	COMMAND DETAIL	APPLIES TO
HT	<p>Set the Pulse High Time</p> <p><u>Operational Note:</u> Applies to Pulse type 1 only.</p> <p>Command: XXXX_HT<cr></p> <p style="padding-left: 20px;">Where XXXX is the pulse high time, in milliseconds. 1 to 4 digits, 1mS to 9999mS.</p> <p>Response: <cr></p>	See Pulsing section of manual
IR	<p>Select POWER CONTROL mode</p> <p>Selects the RF Power Supply's internal power sensor as the feedback source for regulating the RF output level.</p> <p>Related Commands: DL, EL, and W.</p> <p>Command: IR<cr></p> <p>Response: <cr></p>	All
LP	<p>Set the Pulse Low Power Setpoint</p> <p><u>Operational Note:</u> Applies to Pulse type 1 only.</p> <p>Command: XXXXX_LP<cr></p> <p style="padding-left: 20px;">Where XXXX is the pulse low power setpoint, in Watts. 1 to 5 digits, 0 Watts to Rated Power (in Watts)</p> <p>Response: <cr></p>	See Pulsing section of manual
LPS	<p>Query the MC2 Controller's Load Capacitor Preset position.</p> <p>The "LPS" command is passed through the RF Power Supply to an externally connected Seren IPS Inc. model MC2 Matching Network Controller. The MC2's response is passed back through the RF Power Supply to the user's equipment. The RF Power Supply does not use or store the information.</p> <p><u>Operational Note:</u></p> <p style="padding-left: 20px;">Communicating with an MC2 Matching Network Controller via the RF Power Supply requires a serial interface connection from the RF Power Supply to the MC2 matching network controller. Requires serial interface cable assembly 910012XXXX, or serial interface cable assembly 910014XXXX, or custom wiring provided by the user. Consult the factory for assistance.</p> <p>Command: LPS<cr></p> <p>Response: XXX<cr></p> <p style="padding-left: 20px;">Where XXX is the Load Capacitor Preset position stored in the MC2 Matching Network Controller's memory. 0 to 100, in percent. 1 to 3 digits.</p>	All

SERIAL COMMAND DETAILS		
COMMAND	COMMAND DETAIL	APPLIES TO
LR	<p>Sets the output power range to Low Mode</p> <p>Low power range is typically 0 to 10% of rated output power, though some OEM configurations may differ. Power setpoint, forward power metering, and reflected power metering resolution is 0.1Watt</p> <p>Command: LR<cr></p> <p>Response: <cr></p>	Units supporting Low Range operation
LVL?	<p>Query Power Leveling Mode</p> <p>Returns the current power leveling mode:</p> <p>Command: LVL?<cr></p> <p>Response:</p> <p style="padding-left: 20px;">0<cr> for Forward Power Leveling</p> <p style="padding-left: 20px;">1<cr> for Load (net) Power Leveling</p>	All
M?	<p>Query Absolute Maximum Forward Power</p> <p>Command: M?<cr></p> <p>Response: XXXXX<cr></p> <p>Where XXXXX is the Maximum Forward Power of the RF Power Supply, in 1-Watt increments, fixed length: 4 digits (rated power less than 10,000 Watts) or 5 digits (rated power 10,000 Watts or greater). Leading zeros are replaced with the blank space character.</p> <p>Example: A 600 watt unit would return “_600<cr>”</p> <p>This parameter <i>is not</i> configurable.</p>	All
MAG	<p>Query the MC2 Controller's Magnitude Error Voltage</p> <p>The “MAG” command is passed through the RF Power Supply to an externally connected Seren IPS Inc. model MC2 Matching Network Controller. The RF Power Supply does not use or store the information.</p> <p><u>Operational Note:</u></p> <p>Communicating with an MC2 Matching Network Controller via the RF Power Supply requires a serial interface connection from the RF Power Supply to the MC2 matching network controller. Requires serial interface cable assembly 910012XXXX, or serial interface cable assembly 910014XXXX, or custom wiring provided by the user. Consult the factory for assistance.</p> <p>The magnitude error voltage is normally associated with the operation of the matching network's “Load” or “shunt” capacitor.</p> <p>Command: MAG<cr></p> <p>Response: XXXX<cr></p> <p>Where XXXX is the Magnitude Error Voltage, in milli-Volts (mV). 1 to 4 digits.</p>	All

COMMAND	COMMAND DETAIL	APPLIES TO
---------	----------------	------------

MAXPV	Set the Voltage Limit threshold voltage. Command: XXXX_MAXPV Where XXXX is the is the Voltage Limit, in Volts. 1 - 4 digits, 0 to 1000. Setting the Voltage Limit to "0" (zero Volts) disables the Voltage Limit feature. Response: <cr>	All
-------	---	-----

MAXVF	Set the Maximum Frequency for Variable Frequency Tuning Command: XXX_MAXVF<cr> XXX is the maximum allowable frequency, in KHz, for variable frequency tuning, in 1 KHz increments. Response: <cr>	Units configured with adjustable frequency.
-------	--	---

MINVF	Set the Minimum Frequency for Variable Frequency Tuning Command: XXX_MINVF<cr> XXX is the minimum allowable frequency, in KHz, for variable frequency tuning, in 1 KHz increments Response: <cr>	Units configured with adjustable frequency
-------	---	--

MLD	Sets the MC2 Controller for manual operation of the "Load" capacitor The "MLD" command is passed thorough the RF Power Supply to an externally connected Seren IPS Inc. model MC2 Matching Network Controller. The RF Power Supply does not use or store the information.	All
-----	--	-----

Operational Note:

Communicating with an MC2 Matching Network Controller via the RF Power Supply requires a serial interface connection from the RF Power Supply to the MC2 matching network controller. Requires serial interface cable assembly 910012XXXX, or serial interface cable assembly 910014XXXX, or custom wiring provided by the user. Consult the factory for assistance.

Command: MLD<cr>

Response: <cr>

SERIAL COMMAND DETAILS

COMMAND	COMMAND DETAIL	APPLIES TO
MPL	<p>Set the MC2 Controller's Load Capacitor Preset position.</p> <p>The "MPL" command is passed through the RF Power Supply to an externally connected Seren IPS Inc. model MC2 Matching Network Controller. The RF Power Supply does not use or store the information.</p> <p><u>Operational Note:</u> Communicating with an MC2 Matching Network Controller via the RF Power Supply requires a serial interface connection from the RF Power Supply to the MC2 matching network controller. Requires serial interface cable assembly 910012XXXX, or serial interface cable assembly 910014XXXX, or custom wiring provided by the user. Consult the factory for assistance.</p> <p>Command: XXX_MPL<cr> Where XXX is the Load Capacitor Preset position to be stored in the MC2 Matching Network Controller's memory. 0 to 100, in percent. 1 to 3 digits.</p> <p>Response: <cr></p>	All
MPT	<p>Set the MC2 Controller's Tune Capacitor Preset position.</p> <p>The "MPT" command is passed through the RF Power Supply to an externally connected Seren IPS Inc. model MC2 Matching Network Controller. The RF Power Supply does not use or store the information.</p> <p><u>Operational Note:</u> Communicating with an MC2 Matching Network Controller via the RF Power Supply requires a serial interface connection from the RF Power Supply to the MC2 matching network controller. Requires serial interface cable assembly 910012XXXX, or serial interface cable assembly 910014XXXX, or custom wiring provided by the user. Consult the factory for assistance.</p> <p>Command: XXX_MPT<cr> Where XXX is the Tune Capacitor Preset position to be stored in the MC2 Matching Network Controller's memory. 0 to 100, in percent. 1 to 3 digits.</p> <p>Response: <cr></p>	All
MST	<p>Sets the RF Power Supply's Exciter Mode to "MASTER". The RF Power Supply uses its internal frequency source.</p> <p>Command: MST<cr> Response: <cr></p>	All

SERIAL COMMAND DETAILS

COMMAND	COMMAND DETAIL	APPLIES TO
MTN	<p>Sets the MC2 Controller for manual operation of the “Tune” capacitor</p> <p>The “MTN” command is passed thorough the RF Power Supply to an externally connected Seren IPS Inc. model MC2 Matching Network Controller. The RF Power Supply does not use or store the information.</p> <p><u>Operational Note:</u> Communicating with an MC2 Matching Network Controller via the RF Power Supply requires a serial interface connection from the RF Power Supply to the MC2 matching network controller. Requires serial interface cable assembly 910012XXXX, or serial interface cable assembly 910014XXXX, or custom wiring provided by the user. Consult the factory for assistance.</p> <p>Command: MTN<cr> Response: <cr></p>	All
NOECHO	<p>Disable ECHO mode</p> <p>Suppresses the echo of received characters.</p> <p>Command: NOECHO<cr> Response: <cr></p> <p style="padding-left: 20px;">Response for accepted (acknowledged) commands is < cr> Response for invalid commands is N<cr></p>	All
+P	<p>Enable the PULSE mode</p> <p>Enables pulsing of the RF output, per the parameters specified in the programming menu or by the serial command.</p> <p>Related Command: -P</p> <p>Command: +P<cr> Response: <cr></p>	All
-P	<p>Disable the PULSE mode</p> <p>Disables pulsing of the RF output.</p> <p>Related Command: +P</p> <p>Command: -P<cr> Response: <cr></p>	All

COMMAND	COMMAND DETAIL	APPLIES TO
---------	----------------	------------

P1?	<p>Query Power 1 Parameter</p> <p>Command: P1? <cr></p> <p>Response: a_b_ccc_ddd_e_f<cr > (fixed length string)</p> <p>Where:</p> <p>“a” is not implemented, always returns a “0”</p> <p>“b” is not implemented, always returns a “0”</p> <p>“ccc” is the Preset Power 1 Setpoint XXX (in Watts)</p> <p>“ddd” is not implemented, always returns a “000”</p> <p>“e” is not implemented, always returns a “0”</p> <p>“f” is not implemented, always returns a “0”</p> <p><u>Notes:</u></p> <ol style="list-style-type: none"> 1. Leading zeros are replaced with the blank space character. 2. Power Parameters are stored in the RF Power Supply’s memory and can be viewed or edited via the Programming Menu. 3. The RF Power Supply does nothing with these parameters other than providing storage for them. 	Custom OEM Configurations
-----	---	---------------------------

P2?	<p>Query Power 2 Parameter</p> <p>Command: P2? <cr></p> <p>Response: a_b_ccc_ddd_e_f<cr > (fixed length string)</p> <p>Where:</p> <p>“a” is not implemented, always returns a “0”</p> <p>“b” is not implemented, always returns a “0”</p> <p>“ccc” is the Preset Power 2 Setpoint XXX (in Watts)</p> <p>“ddd” is not implemented, always returns a “000”</p> <p>“e” is not implemented, always returns a “0”</p> <p>“f” is not implemented, always returns a “0”</p> <p><u>Notes:</u></p> <ol style="list-style-type: none"> 1. Leading zeros are replaced with the blank space character. 2. Power Parameters are stored in the RF Power Supply’s memory and can be viewed or edited via the Programming Menu. 3. The RF Power Supply does nothing with these parameters other than providing storage for them. 	Custom OEM Configurations
-----	---	---------------------------

SERIAL COMMAND DETAILS		
COMMAND	COMMAND DETAIL	APPLIES TO

P3?	<p>Query Power 3 Parameter</p> <p>Command: P3? <cr></p> <p>Response: a_b_ccc_ddd_e_f<cr > (fixed length string)</p> <p>Where:</p> <p>“a” is not implemented, always returns a “0”</p> <p>“b” is not implemented, always returns a “0”</p> <p>“ccc” is the Preset Power 3 Setpoint XXX (in Watts)</p> <p>“ddd” is not implemented, always returns a “000”</p> <p>“e” is not implemented, always returns a “0”</p> <p>“f” is not implemented, always returns a “0”</p> <p><u>Notes:</u></p> <ol style="list-style-type: none"> 1. Leading zeros are replaced with the blank space character. 2. Power Parameters are stored in the RF Power Supply’s memory and can be viewed or edited via the Programming Menu 3. The RF Power Supply does nothing with these parameters other than providing storage for them. 	Custom OEM Configurations
-----	--	---------------------------

P4?	<p>Query Power 4 Parameter</p> <p>Command: P4? <cr></p> <p>Response: a_b_ccc_ddd_e_f<cr > (fixed length string)</p> <p>Where:</p> <p>“a” is not implemented, always returns a “0”</p> <p>“b” is not implemented, always returns a “0”</p> <p>“ccc” is the Preset Power 4 Setpoint XXX (in Watts)</p> <p>“ddd” is not implemented, always returns a “000”</p> <p>“e” is not implemented, always returns a “0”</p> <p>“f” is not implemented, always returns a “0”</p> <p><u>Notes:</u></p> <ol style="list-style-type: none"> 1. Leading zeros are replaced with the blank space character. 2. Power Parameters are stored in the RF Power Supply’s memory and can be viewed or edited via the Programming Menu. 3. The RF Power Supply does nothing with these parameters other than providing storage for them. 	Custom OEM Configurations
-----	---	---------------------------

SERIAL COMMAND DETAILS		
COMMAND	COMMAND DETAIL	APPLIES TO

P5?	<p>Query Power 5 Parameter</p> <p>Command: P5?<cr></p> <p>Response: a_b_ccc_ddd_e_f<cr > (fixed length string)</p> <p>Where:</p> <p>“a” is not implemented, always returns a “0”</p> <p>“b” is not implemented, always returns a “0”</p> <p>“ccc” is the Preset Power 5 Setpoint XXX (in Watts)</p> <p>“ddd” is not implemented, always returns a “000”</p> <p>“e” is not implemented, always returns a “0”</p> <p>“f” is not implemented, always returns a “0”</p> <p><u>Notes:</u></p> <ol style="list-style-type: none"> 1. Leading zeros are replaced with the blank space character. 2. Power Parameters are stored in the RF Power Supply’s memory and can be viewed or edited via the Programming Menu. 3. The RF Power Supply does nothing with these parameters other than providing storage for them. 	Custom OEM Configurations
-----	--	---------------------------

P6?	<p>Query Power 6 Parameter</p> <p>Command: P6?<cr></p> <p>Response: a_b_ccc_ddd_e_f<cr > (fixed length string)</p> <p>Where:</p> <p>“a” is not implemented, always returns a “0”</p> <p>“b” is not implemented, always returns a “0”</p> <p>“ccc” is the Preset Power 6 Setpoint XXX (in Watts)</p> <p>“ddd” is not implemented, always returns a “000”</p> <p>“e” is not implemented, always returns a “0”</p> <p>“f” is not implemented, always returns a “0”</p> <p><u>Notes:</u></p> <ol style="list-style-type: none"> 1. Leading zeros are replaced with the blank space character. 2. Power Parameters are stored in the RF Power Supply’s memory and can be viewed or edited via the Programming Menu 3. The RF Power Supply does nothing with these parameters other than providing storage for them. 	Custom OEM Configurations
-----	---	---------------------------

SERIAL COMMAND DETAILS

COMMAND	COMMAND DETAIL	APPLIES TO
PANEL	<p>Assert PANEL control</p> <p>Switches control of the unit to the front panel. Power settings and RFON commands from the analog interface or serial interface are ignored.</p> <p><u>Operational Notes:</u></p> <ol style="list-style-type: none"> 1. The RF Power Supply powers-up in the last known control state. 2. Disabling the RF output before changing control modes is recommended. 3. If the RF output is enabled and the PANEL command is issued while operating under ANALOG control, the RF Power Supply's RF output will shut off. 4. If the RF output is enabled and the PANEL command is issued while operating under serial control, the RF power supply's output will remain on. <p>Command: PANEL<cr></p> <p>Response: <cr></p>	All
PHS	<p>Query the MC2 Controller's Phase Error Voltage</p> <p>The "PHS" command is passed through the RF Power Supply to an externally connected Seren IPS Inc. model MC2 Matching Network Controller. The RF Power Supply does not use or store the information.</p> <p><u>Operational Note:</u></p> <p>Communicating with an MC2 Matching Network Controller via the RF Power Supply requires a serial interface connection from the RF Power Supply to the MC2 matching network controller. Requires serial interface cable assembly 910012XXXX, or serial interface cable assembly 910014XXXX, or custom wiring provided by the user. Consult the factory for assistance.</p> <p>The phase error voltage is normally associated with the operation of the matching network's "Tune" or "series" capacitor.</p> <p>Command: PHS<cr></p> <p>Response: XXXX<cr></p> <p>Where XXXX is the Phase Error Voltage, in milli-Volts (mV). 1 to 4 digits.</p>	All
PR	<p>Set the Pulse Frequency</p> <p>Operational Note: Applies to Pulse Type 0 only.</p> <p>Command: XXXXX_PR<cr></p> <p>Where XXXX is the Pulse frequency in Hertz. 1 to 5 digits, 1 to 10,000Hz, in 1Hz increments.</p> <p>Response: <cr></p>	See Pulsing section of manual

COMMAND	COMMAND DETAIL	APPLIES TO
---------	----------------	------------

Q	<p>Query RF Power Supply Status (Long Form)</p> <p>Returns the current status of the RF Power Supply, in the form of a mapped string, terminated with <cr>. The mapped string includes detailed status flags and includes Power Setpoint, Forward and Reflected Power, and rated maximum power.</p> <p>Command: Q<cr></p> <p>Response: XXXXXXXX_aaaa_bbbbb_cccc_ddddd<cr></p> <p style="margin-left: 20px;">Where: aaaa is the setpoint, in Watts bbbb is the Forward Power, in Watts cccc is Reflected Power, in Watts dddd is the rated maximum power, in Watts</p> <p style="margin-left: 20px;">Note: Setpoint, forward power, and reflected power are in Watts if the RF Power Supply is set for high range operation. For low range operation, these values will be in Watts x10. Example: If the RF Power Supply is set for low range and the setpoint is 10.3 watts, the Q command reports the setpoint as 103</p> <p style="margin-left: 40px;">XXXXXXXX is a 7-character ASCII mapped string as described below (characters are counted left-to-right):</p> <p style="margin-left: 20px;"><u>Character # 1: Control Source</u> 2 = Serial Interface, 1 = Analog Interface, 0 = Front Panel</p> <p style="margin-left: 20px;"><u>Character # 2: RF Output Regulation Feedback Source</u> 3 = Internal Sensor (RF Power Control) 0 = External FEEDBACK signal (DC Voltage Control)</p> <p style="margin-left: 20px;"><u>Character #3: Setpoint Source</u> 2 = Serial Interface, 1 = Analog Interface, 0 = Front Panel</p> <p style="margin-left: 20px;">Note: In certain OEM applications, the RF Power Supply is configured so the setpoint is controlled from the front panel while the RF Power Supply is otherwise controlled from the Analog Interface connector. In this case, the Character #1 value will be ASCII 1 (Analog Control) and the Character 3 value will be ASCII 0 (setpoint controlled by front panel).</p> <p style="margin-left: 20px;"><u>Character #4: Status Flags (bit-mapped ASCII)</u> Bit 3: 1 = RF ON, 0 = RF OFF Bit 2: 1 = Reflected Power Limit is active 0 = Reflected Power Limit is inactive Bit 1: 1 = Max Power Limit is active (Max Power Alarm) 0 = Max Power Limit is inactive Bit 0: 1 = PA Current Limit active, 0 = PA Current Limit inactive</p>	All
---	--	-----

SERIAL COMMAND DETAILS

COMMAND	COMMAND DETAIL	APPLIES TO
	<p><u>Character #5: Status Flags (bit-mapped ASCII)</u></p> <p>Bit 3: 1 = The output power is on and is less than the Reflected Power Alarm threshold (RFON&OK) 0 = The Reflected Power Alarm threshold has been exceeded. <u>Note:</u> If RF is off, Bit 3 is set to 0.</p> <p>Bit 2: 1 = Dissipation Limit is active 0 = Dissipation Limit is inactive</p> <p>Bit 1: 1 = CEX is in Slave Mode, 0 = CEX is in Master Mode</p> <p>Bit 0: 1 = Pulse Mode active, 0 = Pulse Mode inactive (CW)</p>	
	<p><u>Character #6: Status Flags (bit-mapped ASCII)</u></p> <p>Bit 3: 1 = Coolant water flow is too low, WTR Alarm Active 0 = Coolant water flow OK, WTR Alarm inactive <u>Note:</u> Applies to water-cooled units only. For air-cooled units, Bit 3 is always set to 0.</p> <p>Bit 2: 1 = HDW Alarm active, output power is disabled 0 = HDW Alarm inactive</p> <p>Bit 1: 1 = External Interlock <u>or</u> RF Cable Interlock open, 0 = External Interlock <u>and</u> RF Cable Interlock OK</p> <p>Bit 0: 1 = Temperature Alarm active, 0 = Temperature Alarm inactive</p>	
	<p><u>Character #7: Communication Link Status</u></p> <p>Bit 0: 1 = Fault. The Communication Link Status feature is active and the RF Power Supply has not received a serial command within the timeout period. 0 = Communication link OK</p> <p><u>Note:</u> The link status fault flag is cleared by issuing any one of the following serial commands: *** , ANALOG, PANEL, SERIAL.</p>	
QAMP	<p>Query the Current output.</p> <p>Returns the current output measured from the analog interface FEEDBACK signal voltage. The value is reported in Amps with 2 decimal places, 0.01 Amp increments.</p> <p>Command: QAMP<cr> Response: XX.XX<cr></p>	Units configured for current control
QDCV	<p>Diagnostic: Query the RF amplifier's DC power supply output voltage.</p> <p>Command: QDCV<cr> Response: XX<cr></p> <p>Where XX is the DC power supply's output, in Volts. 1VDC resolution. Voltage is typically 24-54VDC, depending on model and configuration. Consult Seren technical support for unit-specific information.</p>	All

SERIAL COMMAND DETAILS

COMMAND	COMMAND DETAIL	APPLIES TO
QDIS	<p>Diagnostic: Query the Device Dissipation of the RF amplifier power transistors.</p> <p>Command: QDIS<cr></p> <p>Response: XXX</p> <p style="padding-left: 20px;">Where XXX is the device dissipation per transistor, in Watts.</p> <p>The device dissipation value varies with output power and load conditions. Typically, the value is less than 130Watts per transistor device. Consult Seren technical support for unit-specific information.</p>	All
QFF	<p>Query setpoint, forward power, reflected power, and rated power. Information is returned in a fixed-length text string.</p> <p>Command: QFF<cr></p> <p>Response: aaaaa_bbbbb_ccccc_ddddd<cr> (underscore is space character)</p> <p>Where:</p> <p style="padding-left: 20px;">aaaaa = Setpoint bbbbb = Forward Power ccccc = Reflected Power ddddd = Rated Output Power</p> <p>Leading spaces are padded with the zero (0) character.</p> <p>Example response for a Model R601 RF Power Supply with 125W Setpoint, 125W Forward Power, 2W Reflected Power, 600W rated output power:</p> <p style="padding-left: 40px;">00125_00125_00002_00600<cr></p>	All
QFRQ	<p>Query the RF output frequency.</p> <p>Command: QFRQ<cr></p> <p>Response: XXXXX<cr></p> <p style="padding-left: 20px;">Where XXXXX is the output frequency, in KHz. 1KHz increments, 3 to 5 digits.</p>	All

SERIAL COMMAND DETAILS

COMMAND	COMMAND DETAIL	APPLIES TO
---------	----------------	------------

QOFF	Query the reason/condition that caused the last RF-OFF event.	All
------	---	-----

Command: QOFF<cr>

Response: XXX<cr>

Where XXX is a 3-character string denoting the code for the cause of the last RF-OFF event. Blank characters (spaces) are used to pad the string to 3 digits, if needed. The RF-OFF codes are listed below:

- " " (3 spaces - unknown reason, reason reset, or no RF-OFF yet)
- "ANA" Analog Interface
- "BAL" Imbalance in PA currents
- "BRN" Internal burn-in timer
- "CBL" Cable interlock
- "DCV" DC voltage out of range (typically should be 48V)
- "DN " DeviceNet command
- "DN!" DeviceNet disconnect
- "DN?" DeviceNet card communication timeout
- "EXT" External interlock
- "HDW" Hardware problem
- "IMP" Excessive impedance (XIMP function)
- "LNK" Communication link timeout
- "PAC" One or more PA currents too high
- "PB " Profibus command
- "PB!" Profibus disconnect
- "PB?" Profibus card communication timeout
- "PMD" Mode change from front panel
- "PNL" Front panel RF On/Off button
- "SER" Serial Interface (RS232/RS485)
- "SMD" Mode change from serial port
- "TMP" Temperature too high
- "WTR" Coolant flow
- "XRP" Excessive reflected power
- "ZRV" Low RF voltage after timeout (part of XRFV function)

QPAT	Diagnostic: Query the total (combined) current used by all RF power amplifiers.	All
------	---	-----

Operational Note:

Command is best used when RF output is enabled and setpoint is greater than zero (If RF output is disabled or setpoint is zero, the RF amplifier is shut off and will report 0 current)

Command: QPAT<cr>

Response: XXX<cr>

Where XXX is the total power amplifier current, in Amperes. Resolution is 1A. Total power amplifier current will vary with output power and load conditions.

SERIAL COMMAND DETAILS

COMMAND	COMMAND DETAIL	APPLIES TO
QPAX	<p>Diagnostic: Query individual power amplifier (PA) current.</p> <p><u>Operational Note:</u></p> <ol style="list-style-type: none"> 1. Command is best used when RF output is enabled and setpoint is greater than zero (If RF output is disabled or setpoint is zero, the RF amplifier is shut off and will report 0 current) 2. The QPAX command supports all power amplifier numbers (1 through 8) in all models, however not all models have 8 power amplifiers. Models with less than 8 amplifiers will report a current of zero (0) for the unused amplifier numbers. <p>1-Amplifier Models: R/L101, R/L101MKII, R/L101MKII, R/L301, R/L301MKII, R/L601, R/L1001</p> <p>2-Amplifier Models: R/L2001, R/L2001H, R/L3001</p> <p>4-Amplifier Models: R4001, R/L5001</p> <p>8-Amplifier Models: R10001, R15001</p> <p> </p> <p>Command: QPAX<cr></p> <p style="padding-left: 20px;">Where x is the power amplifier number, 1-8.</p> <p> </p> <p>Response: XX.X</p> <p style="padding-left: 20px;">Where XX.X is the power amplifier current, in Amperes. Resolution is 0.1A. Power amplifier current will vary with output power and load conditions. For a given power level, there may be as much as 2A difference between power amplifier currents.</p>	All
QSET	<p>Query the Setpoint.</p> <p>Returns the setpoint value. Resolution depends on the regulation source and range.</p> <p style="padding-left: 20px;">Power Control, High Range: 1 Watt Power Control, Low Range: 0.1 Watt Voltage Control: 1 Volt Current Control: 0.01A</p> <p> </p> <p>Command: QSET<cr></p> <p>Response: XXXX<cr> (no decimal point)</p>	All
QTMP	<p>Diagnostic: Query the internal RF amplifier heatsink temperature.</p> <p>Returns the internal RF amplifier heatsink temperature in degrees Celsius (°C). Resolution is 0.1°C.</p> <p> </p> <p>Command: QTMP<cr></p> <p>Response: XX.X<cr></p>	All

COMMAND	COMMAND DETAIL	APPLIES TO
---------	----------------	------------

R	<p>Query Status of the RF Power Supply (Short Form)</p> <p>Returns the current status of the RF Power Supply, in the form of a mapped string, terminated with <cr>. The mapped string <i>does not</i> include Power Setpoint, Forward and Reflected Power, and maximum power.</p>	All
---	---	-----

Command: R<cr>

Response: XXXXXXXX<cr>

Where XXXXXXXX is a 7-character ASCII mapped string as described below (characters are counted left-to-right):

Character # 1: Control Source

2 = Serial Interface, 1 = Analog Interface, 0 = Front Panel

Character # 2: RF Output Regulation Feedback Source

3 = Internal Sensor (RF Power Control)
0 = External FEEDBACK signal (DC Voltage Control)

Character #3: Setpoint Source

2 = Serial Interface, 1 = Analog Interface, 0 = Front Panel

Note: In certain OEM applications, the RF Power Supply is configured so the setpoint is controlled from the front panel while the RF Power Supply is otherwise controlled from the Analog Interface connector. In this case, the Character #1 value will be ASCII 1 (Analog Control) and the Character 3 value will be ASCII 0 (setpoint controlled by front panel).

Character #4: Status Flags (bit-mapped ASCII)

Bit 3: 1 = RF ON, 0 = RF OFF
 Bit 2: 1 = Reflected Power Limit is active
 0 = Reflected Power Limit is inactive
 Bit 1: 1 = Max Power Limit is active (Max Power Alarm)
 0 = Max Power Limit is inactive
 Bit 0: 1 = PA Current Limit active, 0 = PA Current Limit inactive

Character #5: Status Flags (bit-mapped ASCII)

Bit 3: 1 = The output power in on and is less than the Reflected Power Alarm threshold (RFON&OK).
 0 = The Reflected Power Alarm threshold has been exceeded.
Note: If RF is off, Bit 3 is set to 0.
 Bit 2: 1 = Dissipation Limit is active
 0 = Dissipation Limit is inactive
 Bit 1: 1 = CEX is in Slave Mode, 0 = CEX is in Master Mode
 Bit 0: 1 = Pulse Mode active, 0 = Pulse Mode inactive (CW)

SERIAL COMMAND DETAILS

COMMAND	COMMAND DETAIL	APPLIES TO
	<p><u>Character #6: Status Flags (bit-mapped ASCII)</u></p> <p>Bit 3: 1 = Coolant water flow is too low, WTR Alarm Active 0 = Coolant water flow OK, WTR Alarm inactive</p> <p><u>Note:</u> Applies to water-cooled units only. For air-cooled units, Bit 3 is always set to 0.</p> <p>Bit 2: 1 = HDW Alarm active, output power is disabled 0 = HDW Alarm inactive</p> <p>Bit 1: 1 = External Interlock <i>or</i> RF Cable Interlock open, 0 = External Interlock <i>and</i> RF Cable Interlock OK</p> <p>Bit 0: 1 = Temperature Alarm active, 0 = Temperature Alarm inactive</p> <p><u>Character #7: Communication Link Status</u></p> <p>Bit 0: 1 = Fault. The Communication Link Status feature is active and the RF Power Supply has not received a serial command within the timeout period. 0 = Communication link OK</p> <p><u>Note:</u> The link status fault flag is cleared by issuing any one of the following serial commands: *** , ANALOG, PANEL, SERIAL.</p>	
R?	<p>Query Reflected Power</p> <p>Command: R?<cr></p> <p>Response: XXXX<cr></p> <p>Where XXXX is the current reflected power, in increments of 1 W (High Range) or increments of 0.1 Watts (Low Range)</p> <p>Length: 4 characters, fixed. Leading zeros are replaced with the blank space character.</p>	All
R?W?R	<p>Concatenated R?, W?, and R Commands</p> <p>Command: R?W?R<cr></p> <p>Response: RRRR_WWWWW_XXXXXXX<cr></p> <p>Where:</p> <p>RRRR is the reflected power, in Watts, length: 4 characters, fixed. Leading zeros are replaced with the blank space character</p> <p>WWWWW is forward power output, in 1-Watt increments, length: 5 characters, fixed. Leading zeros are replaced with the blank space character.</p> <p>XXXXXXX is a 7-character ASCII mapped status string as described in the R command detail.</p>	All
S	<p>Disable the RF Output</p> <p>Command: S<cr></p> <p>Response: <cr></p>	All

COMMAND	COMMAND DETAIL	APPLIES TO
---------	----------------	------------

SERIAL	<p>Assert SERIAL control.</p> <p>Switches control of the unit to the serial interface. Power settings and RF ON commands made via the analog interface or Front Panel are ignored.</p> <p><u>Operational Notes:</u></p> <ol style="list-style-type: none"> 1. The RF Power Supply powers-up in the last known control state. 2. It is advisable to disable RF output before changing control modes. 3. If the RF output is enabled and the unit is operating under Analog control, issuing the SERIAL command will disable RF output. 4. If the RF output is enabled and the unit is operating under Panel control, issuing the SERIAL command <i>will not</i> disable the RF output. 5. This command is similar to the (***) command. <p>Command: SERIAL<cr></p> <p>Response: <cr></p>	All
--------	--	-----

SF	<p>Set Variable Frequency Tuning Strike Frequency</p> <p>With Variable Frequency Enabled, the unit's output frequency defaults to the Strike Frequency setting when the RF output is enabled. If reflected power is greater than the Fine Tuning Trip Level (FT command) the Variable Frequency Tuning feature will automatically adjust the RF output frequency in an attempt to match the load (minimize reflected power).</p> <p><u>Operational Note:</u></p> <p>When the Variable Frequency Tuning feature is enabled, the Strike Frequency overrides the programming menu's operating frequency setting.</p> <p>Related Command: FT</p> <p>Command: XXX_SF<cr></p> <p>XXX is the desired strike (start) frequency, in KHz, 1 KHz increments.</p> <p>Response: <cr></p>	Units configured with adjustable frequency
----	---	--

SLV	<p>Sets the RF Power Supply's Exciter Mode to "SLAVE".</p> <p>The RF Power Supply uses the signal applied to the rear panel CEX IN connector as its frequency source.</p> <p>Command: SLV<cr></p> <p>Response: <cr></p>	All
-----	---	-----

COMMAND	COMMAND DETAIL	APPLIES TO
TPS	<p>Query the Tune Capacitor Preset position.</p> <p>The “TPS” command is passed thorough the RF Power Supply to an externally connected Seren IPS Inc. model MC2 Matching Network Controller. The MC2’s response is passed back through the RF Power Supply to the user’s equipment. The RF Power Supply does not use or store the information.</p> <p><u>Operational Note:</u> Sending the TPS command to the Seren IPS Inc. Model MC2 matching network controller from the RF Power Supply requires a serial interface connection from the RF Power Supply to the MC2 matching network controller. Requires serial interface cable assembly 910012XXXX, serial interface cable assembly 910014XXXX, or custom wiring provided by the user. Consult the factory for assistance.</p> <p>Command: TPS<cr> Response: XXX<cr></p> <p>Where XXX is the Tune Capacitor Preset position stored in the MC2 Matching Network Controller’s memory. 0 to 100, in percent. 1 to 3 digits.</p>	All
UP	<p>Set RF Output Ramp Up time</p> <p>Specifies the Ramp Up time interval, in seconds. When the RF output is enabled (by the front panel, analog interface or the “G” serial command), the RF output power is increased from 0 Watts to the power setpoint over the specified time interval.</p> <p>Factory default value is 1. Related Commands: DN, DU, EU RF output ramping is also configurable via the front panel programming menu.</p> <p>Command: XXXX_UP<cr> Where XXXX is the Ramp Up time interval in seconds. Range: 0 to 9999 seconds, in 1-second increments, 1 to 4 digits.</p> <p>Response: <cr></p>	All
V	<p>Set the Voltage Setpoint</p> <p>Command: XXXX_V<cr> Where XXXX is the desired Voltage setpoint, in 1-Volt increments, 1 to 4 digits.</p> <p>Response: <cr></p>	All
VERS	<p>Query the RF Power Supply's firmware version.</p> <p>Command: VERS<cr> Response: XX.XXXX<cr> Where XX.XXXX is the alpha-numeric version number</p>	All

COMMAND	COMMAND DETAIL	APPLIES TO
VX	Set Variable Frequency Tuning Feature to Enabled Command: VX<cr> Response: <cr>	Units configured with adjustable frequency
V?	Query the Control Voltage Responds with the external feedback (or DC Bias) Voltage, with Probe Attenuation and scaling factors applied. R/LX01 series RF Power supplies have only one external feedback channel, therefore, this command is identical to the “0?” command. A negative (-) polarity signal is assumed. Command: V? Response: XXXX<cr>	All
W	Set the Power Setpoint Command: XXXXX_W<cr> Where XXXXX is the desired setpoint, in 1-Watt increments, 1 to 5 digits. <u>Operational Note:</u> When using low power range, the power setpoint command string must contain a decimal point. Example: Desired power is 10 Watts – send the following command string: 10.0_W<cr> Response: <cr>	All
WG	Set the Power Setpoint and Enable RF Output Command: XXXXX_WG<cr> Where XXXXX is the desired setpoint, in 1-Watt increments, 1 to 5 digits. <u>Operational Note:</u> When using low power range, the power setpoint command string must contain a decimal point. Example: Desired power is 10 Watts – send the following command string: 10.0_WG<cr> Response: <cr>	All
WS	Set the Power Setpoint to 0 Watts and Disable RF Output Command: WS<cr> Response: <cr>	All

SERIAL COMMAND DETAILS

COMMAND	COMMAND DETAIL	APPLIES TO
W?	<p>Query Forward Power Output</p> <p>Command: W?<cr></p> <p>Response: XXXXX<cr></p> <p>Where XXXXX is the current forward power output, in increments of 1 Watt (High Range) or 0.1 Watt (Low Range)</p> <p>Length: 4 digits fixed (rated power less than 10,000 Watts) or 5 digits fixed (rated power 10,000 Watts or greater). Leading zeros are replaced with the blank space character.</p>	All

Serial Communications: RS-485 Protocol

Overview:

Using RS-485 serial communications on the Seren IPS Inc. RX01/LX01 Series RF power supplies:

1. The appropriate serial interface wiring must be connected to the rear panel serial interface connector. Please refer to the serial interface connector details in the Rear Panel Controls and Connections section of this manual.
2. The RF Power Supply's Serial Interface Protocol must be set to "RS485-2" (2-wire) or "RS485-4" (4-wire). The Serial Interface Protocol is configured via the front panel programming menu.
3. The unit's Serial Address must be set to any number from "00" to "99". For multi-drop (bussed) configurations, set the Serial Address to any number from "00" to "98". If the unit's Serial Address is set to "99" the unit can only be used in a single-drop (not bussed) configuration. Serial address "99" is reserved for single-drop serial communications only. The Serial Address is configured via the front panel programming menu.
4. If the Serial Address is less than "99", an ID prefix string must be sent to the RF Power Supply before issuing a command. The ID prefix string is: @XX<cr>, where XX is the Serial Address and <cr> is a carriage return. The RF Power Supply will respond with "A", indicating that it is ready to receive a serial command. Only one serial command can be sent to the RF Power Supply after the ID prefix string is sent. To send another serial command, the ID prefix string must be re-sent, the unit will acknowledge and wait for another serial command.

Note: The Serial Address in the ID prefix string must be two digits. For Serial Addresses less than 10, use a leading zero.

How to Configure the RF Power Supply For RS-485 Communication:

1. Select SERIAL control mode.

Note: The SERIAL control mode only needs to be selected once. The RF power supply will retain the selected control mode during a power-off/power-on cycle.

- a. Press the PGM button (Item 1) once.
- b. Press the DOWN button (item 2) or the UP button (item 3) until line 3 of the display shows the current control source (PANEL CONTROL, ANALOG CONTROL, or SERIAL CONTROL).
- c. Press the VALUE UP button (item 5) or the VALUE DOWN button (item 6) until SERIAL CONTROL is displayed on line 3.
- d. Press the ENT button (item 5) to save the selection.
- e. Remain in the programming environment, ***do not*** press the RUN button.

2. Select the SERIAL COMMUNICATIONS PROTOCOL:

Serial control must be selected before attempting to select the communications protocol. If the unit is set for PANEL or ANALOG control mode, the communications protocol selection will not appear in the programming menu.

Note: The serial communications protocol only needs to be selected once. The RF power supply will retain the selected serial communications protocol during a power-off/power-on cycle.

- a. Press the DOWN button (item 2) or the UP button (item 3) until line 3 of the display shows the current serial communications protocol - RS232, RS422, RS485-4 (4 wire), RS485-2 (2 wire), MODBUS 2W (2 wire) or MODBUS 4W (4 wire).
- b. Press the VALUE UP button (item 5) or the VALUE DOWN button (item 6) until the desired serial protocol "RS485-2" or "RS-485-4" is displayed on line 3
- c. Press the ENT button (item 5) to save the selection.

3. Set the unit's SERIAL ADDRESS

Serial Control *and* RS422 or RS485 protocol must be selected before attempting to set the unit's address. If the unit is set for PANEL or ANALOG control mode, or RS-232 communications protocol, the address selection will not appear in the programming menu.

Note: The serial address only needs to be set once. The RF power supply will retain the selected address during a power-off/power-on cycle.

For single user (single drop) communications, set the unit's Serial Address to "99" (factory default). For multi-drop communications, set the unit's Serial Address to any number from "00" to "98". To avoid address conflicts, consult the system manufacturer's documentation and select an unused RS-485 address.

- a. Press the DOWN button (item 2) or the UP button (item 3) until line 3 of the display shows the address (ADDRESS # XX).
- b. Press the VALUE UP button (item 5) or the VALUE DOWN button (item 6) until the desired address (0-99) is displayed on line 3
- c. Press the ENT button (item 5) to save the selection.

4. Select the BAUD rate:

Serial control must be selected before attempting to select the baud rate. If the unit is set for PANEL or ANALOG control mode, the baud rate selection will not appear in the programming menu.

Note: The BAUD rate only needs to be selected once. The RF power supply will retain the selected BAUD rate during a power-off/power-on cycle.

- a. Press the DOWN button (item 2) or the UP button (item 3) until line 3 of the display shows the current baud rate.
- b. Press the VALUE UP button (item 5) or the VALUE DOWN button (item 6) until the desired baud rate is displayed on line 3

- c. Press the ENT button (item 5) to save the selection.
- d. Press the RUN button (item 5) to exit the programming menu.

Sending Serial Commands via RS-485

The RS-485 serial commands are the same as the RS-232/422 commands listed in the **Serial Command Reference** and **Serial Command Details** sections. Because multiple units can be connected (bussed) together, communications using RS-485 requires addressing of the desired unit before each command is sent.

Notes:

- The underscore character (_) indicates a space, terminators are specified as carriage return <cr>.
- Unless otherwise specified, with ECHO mode set to *disabled*, the RF Power Supply responds with <cr>” for an accepted command, or “N<cr>” for an invalid command.
- Unless otherwise specified, with ECHO mode set to *enabled*, the RF Power Supply echoes (transmits) any character it receives as soon as the character is received. A command is checked for validity after the carriage return <cr> character is received. Once the <cr> is received, the response to the command is the same whether ECHO mode is enabled or disabled.
- The RF Power Supply processes ASCII characters with values of 32 through 127 (hex 20 through 7F) and the carriage return character (13 or hex 0D). All other characters are ignored and are not echoed.
- RS-485 (2-wire) communications protocol does not support ECHO mode (set to *disabled* by software default).
- RS-422 communications protocol mode is listen-only.

RS-485 Command Process:

1. Send the ID Prefix:

@XX<cr>	Where XX is the RF Power Supply's SERIAL ADDRESS, "00" to "99".
---------	---
2. The RF Power Supply will respond with:

A	The RF Power Supply is waiting to accept a command.
---	---
3. Send the serial command:

W?<cr>	Query the forward power output (example)
--------	--
4. The RF Power Supply will send the command response:

XXXXX<cr>	Where, in this example, XXXXX is the forward output power in Watts.
-----------	---
5. To send additional commands, repeat steps 1 through 4.

Serial Communications: MODBUS Protocol

Overview:

MODBUS functions on the RX01/LX01 Series RF Power Supplies, are implemented as a MODBUS RTU application with a 2-wire or 4-wire interface connection. For interface wiring information, please refer the Serial Interface connector details in the Rear Panel Controls and Connections section.

Supported Functions/Modes	
Mode:	RTU
<hr/>	
Electrical Interface	
Connection:	RS-485 2-wire or 4-wire
Coding:	1 start bit, 8 data bits, 1 parity bit (even), 1 stop bit
Data Rate:	1200, 2400, 4800, 38.4k, 56k, 115k bps
Connector:	9 pin female "D" type , refer to Rear Panel Controls and Connections section for pin list
Terminations:	Not included
<hr/>	
Addressing	
Type:	Slave Only
Mode:	Unicast
Address Range:	1 to 247
<hr/>	
Function Codes	
READ HOLDING REGISTER:	0x03, used to recover status, setup
WRITE MULTIPLE REGISTER:	0x10, used to control
SLAVE ID:	0x11
<hr/>	
Exception Codes	
Illegal Function:	0x01
Illegal Address:	0x02
Illegal Data Value:	0x03
<hr/>	
Visual Diagnostics:	Not implemented.

How To Configure the RF Power Supply for MODBUS Communications:

1. Select SERIAL control mode.

Note: The SERIAL control mode only needs to be selected once. The RF power supply will retain the selected control mode during a power-off/power-on cycle.

- a. Press the PGM button (Item 1) once.
- b. Press the DOWN button (item 2) or the UP button (item 3) until line 3 of the display shows the current control source (PANEL CONTROL, ANALOG CONTROL, or SERIAL CONTROL).
- c. Press the VALUE UP button (item 5) or the VALUE DOWN button (item 6) until SERIAL CONTROL is displayed on line 3.
- d. Press the ENT button (item 5) to save the selection.
- e. Remain in the programming environment, ***do not*** press the RUN button.

2. Select the SERIAL COMMUNICATIONS PROTOCOL:

Serial control must be selected before attempting to select the communications protocol. If the unit is set for PANEL or ANALOG control mode, the communications protocol selection will not appear in the programming menu.

Note: The serial communications protocol only needs to be selected once. The RF power supply will retain the selected serial communications protocol during a power-off/power-on cycle.

- a. Press the DOWN button (item 2) or the UP button (item 3) until line 3 of the display shows the current serial communications protocol - RS232, RS422, RS485-4 (4 wire), RS485-2 (2 wire), MODBUS 2W (2 wire) or MODBUS 4W (4 wire).
- b. Press the VALUE UP button (item 5) or the VALUE DOWN button (item 6) until the desired serial protocol “MODBUS 4W RTU” or “MODBUS 2W RTU” is displayed on line 3
- c. Press the ENT button (item 5) to save the selection.

3. Set the unit's SERIAL ADDRESS

Serial Control *and* MODBUS protocol must be selected before attempting to set the unit's address. If the unit is set for PANEL or ANALOG control mode, or RS-232 communications protocol, the address selection will not appear in the programming menu.

Note: The serial address only needs to be set once. The RF power supply will retain the selected address during a power-off/power-on cycle.

For single user (single drop) communications, set the unit's Serial Address to “99” (factory default). For multi-drop communications, set the unit's Serial Address to any number from “1” to “247”. To avoid address conflicts, consult the system manufacturer's documentation and select an unused MODBUS address.

- a. Press the DOWN button (item 2) or the UP button (item 3) until line 3 of the display shows the address (ADDRESS # XXX).
- b. Press the VALUE UP button (item 5) or the VALUE DOWN button (item 6) until the desired address (1-247) is displayed on line 3
- c. Press the ENT button (item 5) to save the selection.

4. Select the BAUD rate:

Serial control must be selected before attempting to select the baud rate. If the unit is set for PANEL or ANALOG control mode, the baud rate selection will not appear in the programming menu.

Note: The BAUD rate only needs to be selected once. The RF power supply will retain the selected BAUD rate during a power-off/power-on cycle.

- a. Press the DOWN button (item 2) or the UP button (item 3) until line 3 of the display shows the current baud rate.
- b. Press the VALUE UP button (item 5) or the VALUE DOWN button (item 6) until the desired baud rate is displayed on line 3
- c. Press the ENT button (item 5) to save the selection.
- d. Press the RUN button (item 5) to exit the programming menu.

MODBUS Commands

Controller WRITE PACKET

The WRITE PACKET is used to configure and control the RF Power Supply. Use the Write MULTIPLE REGISTERS function code, 0x10, with an address of 1, count of 24 to fully configure the RF Power Supply. To change power setpoint and turn RF ON or turn RF OFF, use WORD1 only, with RFON/OFF embedded in B15. Address=(1), Count=1

READ SETUP PACKET = [WORD0]...[WORD23]

Send words 1-23 on power-up, RF OFF, and configuration changes.

Send words 1-3 with RF ON, to change setpoint, or turn RF OFF.

The word definitions in the table below refer to programmable parameters. For programmable parameter details, refer to the **Programmable Parameters Details** section of this manual

MODBUS WRITE PACKET WORD DEFINITIONS

WORD1: Setpoint and RFON/OFF

MSB	LSB
[B15 XXXXXXXX]	[XXXXXXXX B0]

B15 = RF ON/OFF	B15=1, RFON B15=0, RF OFF
B14 through B0	SETPOINT VALUE

MODBUS WRITE PACKET WORD DEFINITIONS

WORD2: Operating Frequency (applies to Variable Frequency units only)

MSB	LSB
[B15 XXXXXXXX]	[XXXXXXXX B0]

B15 through B0	Operating frequency, in KHz. Variable Frequency units only. Ignored by Fixed frequency units
----------------	--

WORD3: Control Bits

MSB	LSB
[XXXXXX B10 B9 B8]	[B7 B6 B5 B4 B3 B2 B1 B0]

B10, B9: Control Mode	B10=0, B9=0 Panel Control B10=0, B9=1 Analog Control B10=1, B9=0 Serial Control
-----------------------	---

B8: Pulse Mode	B8=0 Pulse Off B8=1 Pulse On
----------------	---------------------------------

B7: Reserved	B7: Reserved
--------------	--------------

B6: Power/Voltage Control	B6=0 Power Control B6=1 Voltage Control
---------------------------	--

B5: Analog Range	B5=0 Range 5V B5=1 Range 10V
------------------	---------------------------------

B4: Leveling	B4=0 Forward Power Leveling B4=1 Load Power Leveling
--------------	---

B3: Power Range	B3=0 High Range B3=1 Low Range
-----------------	-----------------------------------

B2: CEX Mode	B2=0 Master B2=1 Slave
--------------	---------------------------

B1: Match Preset Enable/Disable	B1=0 Match Preset Disabled B1=1 Match Preset Enabled
---------------------------------	---

B0: Variable Frequency Tuning	B0=0 Variable Frequency Tuning Off B0=1 Variable Frequency Tuning ON
-------------------------------	---

MODBUS WRITE PACKET WORD DEFINITIONS

WORD4: Maximum Frequency

MSB	LSB
[B15 XXXXXXXX] [XXXXXXXX B0]	
B15 through B0	Maximum Operating Frequency. Applies to variable frequency units only. Ignored by fixed frequency units.

WORD5: Minimum Frequency

MSB	LSB
[B15 XXXXXXXX] [XXXXXXXX B0]	
B15 through B0	Minimum Operating Frequency. Applies to variable frequency units only. Ignored by fixed frequency units.

WORD6: High Power Pulse

MSB	LSB
[B15 XXXXXXXX] [XXXXXXXX B0]	
B15 through B0	High power pulse setting, in Watts.

WORD7: Low Power Pulse

MSB	LSB
[B15 XXXXXXXX] [XXXXXXXX B0]	
B15 through B0	Low power pulse setting, in Watts.

WORD8: Pulse Frequency

MSB	LSB
[B15 XXXXXXXX] [XXXXXXXX B0]	
B15 through B0	Pulse Frequency, in Hertz (Hz), 1Hz increments.

WORD9: Pulse HI Time

MSB	LSB
[B15 XXXXXXXX] [XXXXXXXX B0]	
B15 through B0	Pulse HI time, in milli-seconds, 1 mS increments.

WORD10: Pulse High Time

MSB	LSB
[B15 XXXXXXXX] [XXXXXXXX B0]	
B15 through B0	Pulse High time, in milli-seconds, 1 mS increments.

MODBUS WRITE PACKET WORD DEFINITIONS

WORD11: Pulse Duty Cycle

MSB	LSB
[B15 XXXXXXXX]	[XXXXXXXX B0]
B15 through B0	Pulse duty cycle. 1% increments.

WORD12: Maximum Power

MSB	LSB
[B15 XXXXXXXX]	[XXXXXXXX B0]
B15 through B0	Maximum Forward Power, in Watts.

WORD13: Maximum Voltage

MSB	LSB
[B15 XXXXXXXX]	[XXXXXXXX B0]
B15 through B0	Maximum Voltage, in Volts.

WORD14: Probe Factor

MSB	LSB
[B15 XXXXXXXX]	[XXXXXXXX B0]
B15 through B0	Voltage Feedback Probe Attenuation factor, XXXX:1.

WORD15: Load Preset

MSB	LSB
[B15 XXXXXXXX]	[XXXXXXXX B0]
B15 through B0	Load Capacitor Preset Value, 0 to 100%

WORD16: Tune Preset

MSB	LSB
[B15 XXXXXXXX]	[XXXXXXXX B0]
B15 through B0	Tune Capacitor Preset Value, 0 to 100%

WORD17: Frequency Tune – Set Coarse Ratio

MSB	LSB
[B15 XXXXXXXX]	[XXXXXXXX B0]
B15 through B0	Coarse Ratio, XXX:1

WORD18: Frequency Tune – Set Fine Trip

MSB	LSB
[B15 XXXXXXXX]	[XXXXXXXX B0]
B15 through B0	Fine Tune Trip Point, in Watts.

MODBUS WRITE PACKET WORD DEFINITIONS

WORD19: Frequency Tune – Set Coarse Frequency

MSB	LSB
[B15 XXXXXXXX]	[XXXXXXXX B0]
B15 through B0	Coarse Frequency, in Hertz. 1Hz increments.

WORD20: Frequency Tune – Set Fine Frequency

MSB	LSB
[B15 XXXXXXXX]	[XXXXXXXX B0]
B15 through B0	Fine Frequency, in Hertz. 1Hz increments.

WORD21: Frequency Tune – Set Strike Frequency

MSB	LSB
[B15 XXXXXXXX]	[XXXXXXXX B0]
B15 through B0	Strike Frequency, in Hertz. 1Hz increments.

WORD22: Frequency Tune – Set Maximum Variable Frequency

MSB	LSB
[B15 XXXXXXXX]	[XXXXXXXX B0]
B15 through B0	Maximum allowable frequency limit for Variable Frequency Tuning, in Hertz. 1Hz increments.

WORD23: Frequency Tune – Set Minimum Variable Frequency

MSB	LSB
[B15 XXXXXXXX]	[XXXXXXXX B0]
B15 through B0	Minimum allowable frequency limit for Variable Frequency Tuning, in Hertz. 1Hz increments.

WORD24: Reserved

MSB	LSB
[B15 XXXXXXXX]	[XXXXXXXX B0]
B15 through B0	Reserved

Controller READ PACKET

Access with READ HOLDING REGISTER command 0X03. Address is (25) decimal, with a count of 4.

MODBUS READ PACKET WORD DEFINITIONS

WORD0: RFON/OFF, Forward Power

MSB	LSB
[B15 XXXXXXXX]	[XXXXXXXX B0]
B15 = RF ON/OFF	B15=1, RFON B15=0, RF OFF
B14 through B0	Forward Power, in Watts

WORD1: RFON/OFF, Reflected Power

MSB	LSB
[B15 XXXXXXXX]	[XXXXXXXX B0]
B15 = RF ON/OFF	B15=1, RFON B15=0, RF OFF
B14 through B0	Reflected Power, in Watts

WORD2: Operating Frequency (applies to Variable Frequency units only)

MSB	LSB
[B15 XXXXXXXX]	[XXXXXXXX B0]
B15 through B0	Operating frequency, in KHz. Variable Frequency units only. Ignored by Fixed frequency units

WORD3: Status

MSB	LSB
[B15 XXXXXXXX]	[B7 B6 B5 B4 B3 B2 B1 B0]
B7: Power Amplifier (PA)	B7=0 PA OK B7=1 PA Unbalance Alarm
B6: Reserved	Reserved
B5: Reflected Alarm	B5=0 Reflected OK B5=1 Reflected Power Alarm
B4: Max Power Alarm	B4=0 OK B4=1 Max Power Alarm
B3: Temperature Alarm	B3=0 Temperature OK B3=1 Temperature Alarm
B2: RF ON/OFF	B2=0 RF OFF B2=1 RF ON

MODBUS READ PACKET WORD DEFINITIONS

B1: External Interlock	B1=0 External Interlock Closed (OK) B1=1 External Interlock Open (Alarm)
B0: RF Alarm	B0=0 RF No Alarm B0=1 RF OK

Controller READ SLAVE ID

The READ SLAVE ID command, 0x11 may be used to obtain a brief status and identity of the RF Power Supply.

MODBUS READ SLAVE ID WORD DEFINITIONS

WORD0: Seren IPS Inc. Part Number, High Word

MSB	LSB
[B15 XXXXXXXX]	[XXXXXXXX B0]
B15 through B0	Seren IPS Inc. part number, high word.

WORD1: Seren IPS Inc. Part Number, Low Word

MSB	LSB
[B15 XXXXXXXX]	[XXXXXXXX B0]
B15 through B0	Seren IPS Inc. part number, low word.

WORD2: Seren IPS Inc. Serial Number

MSB	LSB
[B15 XXXXXXXX]	[XXXXXXXX B0]
B15 through B0	Seren IPS Inc. serial number.

WORD3: RF ON/OFF

MSB	LSB
[B15 XXXXXXXX]	[XXXXXXXX B0]
B15 through B0	255 = RFON 0 = RF OFF

WORD4: Forward RF Power

MSB	LSB
[B15 XXXXXXXX]	[XXXXXXXX B0]
B15 through B0	Forward RF Power, in Watts.

WORD5: Reflected RF Power

MSB	LSB
[B15 XXXXXXXX]	[XXXXXXXX B0]
B15 through B0	Reflected RF Power, in Watts.

DeviceNet™ Communications

Seren IPS Inc. R/LX01-Series RF Power Supplies support several serial communications modes and interfaces. The communications mode is configured from the front-panel programming menu. Available communications modes are: RS-232, RS-422, RS-485 4 Wire, RS-485 2 Wire, MODBUS 4 Wire RTU, MODBUS 2 Wire RTU, ProfiBus, and DeviceNet. ***DeviceNet is an optional communications interface***, and is not field-installable.

This section describes the usage and commands applicable to DeviceNet. RS-232, RS-422, RS-485 and MODBUS serial protocols are discussed in its own section, and PROFIBUS communications are described in a separate document.

The DeviceNet interface connector, located on the rear panel of the RF Power Supply is detailed in the Rear Panel Controls And Connections section

DeviceNet Technical Information

Applicable Documents:

Title:	DeviceNet Specification Volume I: DeviceNet Communication Model and Protocol
Version	Release 2.0, Errata 5 March 31, 2002
Source	ODVA
Title:	DeviceNet Specification Volume II: DeviceNet Device Profiles and Object Library
Version	Release 2.0, Errata 5 March 31, 2002
Source	ODVA
Title:	Interface Guidelines for DeviceNet Devices On Semiconductor Manufacturing Tools
Version	Revision: 2.5 09-Sept-2005
Source	ODVA

Hardware:

Status Indicators:	Network Status LED, Module Status LED
Configuration Switches:	Communication Rate: Rotary Switch (0=125kbaud, 1=250kbaud, 2=500kbaud, others="program") MAC ID: Rotary Switches (settings 0-63=ID, others="program") NOTE: On smaller RF Power Supplies models such as the R/L301MKII, R/L601, and R/L1001, DeviceNet configuration switches are not provided. For these units, the MAC ID and Communication Rate must be set from the front panel.
Connector Style:	Sealed Micro, Male
Physical Layer:	Philips PCA82C250 CAN controller, optically isolated

Software:

Communications Model: Group 2 Only Server
 Predefined Master/Slave Connection Set supported

Connections: Connection Instance 1: Explicit
 Connection Instance 2: Polled I/O

Specifications: Vendor ID: 946 (3B2 hex)
 Message body format: DeviceNet 8/8
 Minimum time between I/O Poll Commands: 50 ms

When the RF Power Supply is powered up, it executes a self-test, sending two "Duplicate MAC ID check" messages, then waits for a Master to establish a connection. To set up a connection, a Master should send "Allocate Master/Slave Connection Set" followed by "Set Single Attribute - Expected Packet Rate". After the connection is established, the Master may issue I/O Poll Command messages and the RF Power Supply will respond with I/O Poll Response messages.

In the following examples, the Master's MAC ID is 01, and the Slave's MAC ID is 3F. Values are in hexadecimal.

Example 1: Allocate Master/Slave Connection Set

CAN ID:	5FE	Group 2, Destination MAC ID 3F, Message ID 6
Data Byte Count	6	
Data:	01	Message header - source ID = 01
	4B	Service code = Allocate M/S Connection Set
	03	Class ID = DeviceNet
	01	Instance ID = 01
	03	Allocation choice = Polled + Explicit
	01	Allocator's MAC ID = 01

Example 2: Set Expected Packet Rate for the I/O Poll Connection

CAN ID:	5FC	Group 2, Destination MAC ID 3F, Message ID 4
Data Byte Count:	7	
Data:	01	Message header - source ID = 01
	10	Service code = Set Attribute Single
	05	Class ID = Connection
	02	Instance ID = I/O Poll
	09	Attribute = Expected Packet Rate
	00	Value LSB
	04	Value MSB Value = 0400 = 1024 ₁₀ ms

DeviceNet I/O Poll Command/Response Assembly Data Formats

While the RF Power Supply is connected to the Master and I/O Polling is in progress, the Master periodically sends a data packet to the RF Power Supply and the RF Power Supply sends a data packet in response. In DeviceNet terminology, each data packet is called an "assembly". The direction of data transfer is always with respect to the Master, so that "out" means "from Master to Slave" and "in" means "from Slave to Master".

The format of the data within each assembly depends on which "Assembly Set" is selected. The RF Power Supply supports three Assembly Sets, each with different sizes and capabilities, depending on the application. With Assembly Set 1 selected, the amount of data transferred is very small, but the RF Power Supply operation is limited to specifying the setpoint and turning RF power on and off. With Assembly Set 2 selected, nearly every RF Power Supply function is available, however the amount of data transferred is larger. Assembly Set 3 includes a subset of the functions available with Assembly Set 2, with correspondingly less data transferred.

The desired Assembly Set can be selected via DeviceNet by sending a Set Attribute Single explicit message to set the Consumed Connection Path of the I/O Poll Connection:

Assembly Set 1:	Set Attribute Single 20 04 24 64 30 03
Assembly Set 2:	Set Attribute Single 20 04 24 66 30 03
Assembly Set 3:	Set Attribute Single 20 04 24 68 30 03

When an Assembly Set is selected, the setting is retained while the RF Power Supply's AC mains is powered off, so that it will not be necessary to re-select the Assembly Set each time the RF Power Supply is powered on.

The desired Assembly Set can also be selected from the front panel, as described below in the [How to Configure the RF Power Supply for DeviceNet Communications](#) section.

Note: The information above applies to RF Power Supplies with firmware version 11.3W02 and above. With earlier firmware, only Assembly Sets 1 and 2 are supported, and the RF Power Supply resets to Assembly Set 1 if AC mains is powered off and back on again.

The formats of the assemblies are described in the following sections.

Assembly Set 1: I/O Poll Command Format - Assembly ID 64hex (Factory Default)

From Fieldbus To RF Power Supply. This assembly is sent from the Master to the RF Power Supply, and is used to set various parameters as follows:

Assembly Set 1: Assembly ID 64hex Commands / Parameters Format								
BYTE	7	6	5	4	3	2	1	0
0	Power Output LSB							
1	Power Output MSB							
2	Not Used							
3	Not Used							
4								RFEN

Assembly Set 1: Assembly ID 64hex Commands / Parameters	
BYTE	Command / Parameter Detail
Bytes 0,1	Forward Power in Watts (byte 0 = LSB, byte 1 = MSB)
Byte 4, Bit 0	RF Enable Control: 1 = RF On 0 = RF Off

Assembly Set 1: I/O Poll Response Format - Assembly ID 65hex (Factory Default)

From RF Power Supply To Fieldbus. This assembly is sent from the RF Power Supply to the Master, and is used to report the current values of various parameters as follows:

Assembly Set 1: Assembly ID 65hex I/O Poll Response Data Format								
BYTE	7	6	5	4	3	2	1	0
0	Forward Power LSB							
1	Forward Power MSB							
2	Reflected Power LSB							
3	Reflected Power MSB							
4	DC Voltage Probe LSB							
5	DC Voltage Probe MSB							
6	Not Used							
7	Not Used							
8	ICT	ICE	LEVEL	EXT	HDW	TMP	CMP	RFON

Assembly Set 1: Assembly ID 65hex I/O Poll Response Data			
BYTE	Data Detail		
Bytes 0,1	Forward Power in Watts (byte 0 = LSB, byte 1 = MSB)		
Bytes 2,3	Reflected Power in Watts (byte 2 = LSB, byte 3 = MSB)		
Bytes 4,5	DC Probe Voltage (byte 4 = LSB, byte 5 = MSB)		
Bytes 6,7	(reserved)		
Byte 8 bit 7	ICT	Internal Comm Timeout	1 = RF Power Supply CPU not responding (Mod LED red)
Byte 8 bit 6	ICE	Internal Comm Error	1 = alarm condition
Byte 8 bit 5	LEVEL	Power Leveling Mode	0 = Forward Power, 1 = Load (Net) Power
Byte 8 bit 4	EXT	External interlock	1 = OK, 0 = alarm condition
Byte 8 bit 3	HDW	Hardware Fault	1 = RF Power Supply not operating properly (Mod LED red)
Byte 8 bit 2	TMP	Temperature	1 = OK, 0 = alarm condition
Byte 8 bit 1	CMP	Compliance	1 = setpoint reached
Byte 8 bit 0	RFON	RF Output	1 = RF output is ON

Assembly Set 2: I/O Poll Command Format - Assembly ID 66hex

From Fieldbus To RF Power Supply. This assembly is sent from the Master to the RF Power Supply, and is used to set various parameters as follows:

Assembly Set 2: Assembly ID 66hex Commands/Parameters Format								
BYTE	7	6	5	4	3	2	1	0
0	Setpoint (low byte)							
1	Setpoint (high byte)							
2	MaxPwr (low byte)							
3	MaxPwr (high byte)							
4	Freq (low byte)							
5	Freq (high byte)							
6	MaxFreq (low byte)							
7	MaxFreq (high byte)							
8	MinFreq (low byte)							
9	MinFreq (high byte)							
10	MaxV (low byte)							
11	MaxV (high byte)							
12	PulsHiPwr (low byte)							
13	PulsHiPwr (high byte)							
14	PulsLoPwr (low byte)							
15	PulsLoPwr (high byte)							

Assembly Set 2: Assembly ID 66hex Commands/Parameters Format								
BYTE	7	6	5	4	3	2	1	0
16	PulsRate (low byte)							
17	PulsRate (high byte)							
18	PulsHiTime (low byte)							
19	PulsHiTime (high byte)							
20	RampUp (low byte)							
21	RampUp (high byte)							
22	RampDn (low byte)							
23	RampDn (high byte)							
24	MaxVF (low byte)							
25	MaxVF (high byte)							
26	MinVF (low byte)							
27	MinVF (high byte)							
28	CoarseF (low byte)							
29	CoarseF (high byte)							
30	FineF (low byte)							
31	FineF (high byte)							
32	StrikeF (low byte)							
33	StrikeF (high byte)							
34	(res)							
35	(res)							
36	CtrlMode							
37	PulsDuty							
38	PresetEna							
39	PreTune							
40	PreLoad							
41	CoarseR							
42	FineT							
43	TuneFB							
44	LinkTimer							
45	MatchLoad							
46	MatchTune							
47	(res)							
48	FreqCtrl	PrbPol	Rng5/10	ExcCtrl	RngPwr	Level	RegPV	RFEN
49	FreqTune	MatchConn	RampEna	(res)	PlsMon	PlsSrc	(res)	PlsEna
50	(res)	(res)	(res)	LinkMon	(res)	(res)	XrfvEna	XimpEna
51	(res)	(res)	(res)	(res)	(res)	(res)	(res)	IGNORE

This assembly is sent from the Master to the RF Power Supply, and is used to set various parameters as follows:

Assembly Set 2: Assembly ID 66hex Commands / Parameters	
BYTE	Command / Parameter Detail
Bytes 0,1	Setpoint - Power or Voltage Setpoint If RegPV=0 and RngPwr=0: value in Watts*10, min = 0, max = MaxPwr If RegPV=0 and RngPwr=1: value in Watts, min = 0, max = MaxPwr If RegPV=1: value in Volts, min = 0, max = MaxV
Bytes 2,3	MaxPwr - Maximum Power If RngPwr=0: value in Watts, min = 0, max = rated power / 10 If RngPwr=1: value in Watts, min = 0, max = rated power
Bytes 4,5	Freq - RF Power Supply Output Frequency Value in KHz, min = MinFreq, max = MaxFreq
Bytes 6,7	MaxFreq - Maximum Output Frequency Value in KHz, min = min rated freq, max = max rated freq
Bytes 8,9	MinFreq - Minimum Output Frequency Value in KHz, min = min rated freq, max = max rated freq
Bytes 10,11	MaxV - Maximum DC Voltage in Voltage Control Value in Volts, min = 0, max = rated F.S.
Bytes 12,13	PulsHiPwr - Pulse High Power (Pulse Type 1) Value in Watts, min = 0, max = MaxPwr
Bytes 14,15	PulsLoPwr - Pulse Low Power (Pulse Type 1) Value in Watts, min = 0, max = MaxPwr
Bytes 16,17	PulsRate - Pulse Rate (Pulse Type 0) Value in Hz, min = 1, max = 10000
Bytes 18,19	PulsHiTime - Pulse High Time (Pulse Type 1) Value in mS, min = 1, max = 9999
Bytes 20,21	RampUp - Ramp-Up Time Value in S, min = 1, max = 9999
Bytes 22,23	RampDn - Ramp-Down Time Value in S, min = 1, max = 9999
Bytes 24,25	MaxVF - Maximum Tune Frequency Value in KHz, min = min rated freq, max = max rated freq
Bytes 26,27	MinVF - Minimum Tune Frequency Value in KHz, min = min rated freq, max = max rated freq
Bytes 28,29	CoarseF - Coarse Tune Frequency Step Value in Hz, min = 1, max = 30000
Bytes 30,31	FineF - Fine Tune Frequency Step Value in Hz, min = 1, max = 30000

Assembly Set 2: Assembly ID 66hex Commands / Parameters	
BYTE	Command / Parameter Detail
Bytes 32,33	StrikeF - Strike Frequency Value in KHz, min = MinVF, max = MaxVF
Byte 36	CtrlMode - Control Mode 0 = Panel Control 1 = Analog Control 2 = Serial Control
Byte 37	PulsDuty - Pulse Duty Cycle Value in percent, min = 0, max = 100
Byte 38	PresetEna - Preset Mode Enable 0 = disabled 1 = enabled (standard rfok output) 2 = enabled (inverted rfok output)
Byte 39	PreTune - Tune Preset Value in percent, min = 0, max = 100
Byte 40	PreLoad - Load Preset Value in percent, min = 0, max = 100
Byte 41	CoarseR - Coarse Tune Trip Ratio Value in percent, min = 1, max = 100
Byte 42	FineT - Fine Tune Suspension Point Value in Watts, min = 1, max = 100
Byte 43	TuneFB - Tune Feedback Source 0 = reflected power 1 = external phase detector, positive polarity 2 = external phase detector, negative polarity
Byte 44	LinkTimer - Link Loss Detection Timer Value in Seconds, min = 0, max = 30
Byte 45	MatchLoad - Match Load Position Value in percent, min = 0, max = 100
Byte 46	MatchTune - Match Tune Position Value in percent, min = 0, max = 100
Byte 48 bit 7	FreqCtrl - Frequency Control Enable 0 = Disabled 1 = Enabled
Byte 48 bit 6	PrbPol - Probe Polarity 0 = +PRB DB25 (probe inverter disabled) 1 = -PRB BNC (probe inverter enabled)
Byte 48 bit 5	Rng5/10 - Analog Interface Range Select, 5V or 10V 0 = 5V F.S. 1 = 10V F.S.

Assembly Set 2: Assembly ID 66hex Commands / Parameters	
BYTE	Command / Parameter Detail
Byte 48 bit 4	ExcCtrl - Exciter Control 0 = Master 1 = Slave
Byte 48 bit 3	RngPwr - Range Select, Low or High Power 0 = Low Power Range 1 = High Power Range
Byte 48 bit 2	Level - Level Mode 0 = Regulate on forward power 1 = Regulate on forward power - reflected power
Byte 48 bit 1	RegPV - Regulation Type, Power or Voltage 0 = Regulate on power 1 = Regulate on voltage
Byte 48 bit 0	RFEN - RF Off/On Control 0 = RF Off 1 = RF On
Byte 49 bit 7	FreqTune - Frequency Tune Enable 0 = Disabled 1 = Enabled
Byte 49 bit 6	MatchConn - Connect to Match Controller 0 = Do not connect 1 = Connect : send desired match/load positions, report current positions
Byte 49 bit 5	RampEna - Ramping Enable 0 = Disabled 1 = Enabled
Byte 49 bit 3	PlsMon - Pulse Monitor Output (Type 1) 0 = Peak 1 = Real time
Byte 49 bit 2	PlsSrc - Pulse Source 0 = Internal 1 = External
Byte 49 bit 0	PlsEna - Pulse Enable 0 = Disabled 1 = Enabled
Byte 50 bit 4	LinkMon - Link Loss Monitor Enable 0 = Disabled 1 = Enabled
Byte 50 bit 1	XrfvEna - Excessive RF Voltage Alarm Enable 0 = Disabled 1 = Enabled
Byte 50 bit 0	XimpEna - Excessive Impedance Alarm Enable 0 = Disabled 1 = Enabled

Assembly Set 2: Assembly ID 66hex Commands / Parameters	
BYTE	Command / Parameter Detail
Byte 51 bit 0	IGNORE - Ignore All Parameters in I/O Poll Command 0 = Process all parameters in the I/O Poll Command 1 = Ignore all parameters in the I/O Poll Command Use this when only the I/O Poll Response is desired.

Assembly Set 2: I/O Poll Response Format - Assembly ID 67hex

This assembly is sent from the RF Power Supply to the Master, and is used to report the current values of various parameters as follows:

Assembly Set 2: Assembly ID 67hex I/O Poll Response Data Format								
BYTE	7	6	5	4	3	2	1	0
0	Setpoint (low byte)							
1	Setpoint (high byte)							
2	MaxPwr (low byte)							
3	MaxPwr (high byte)							
4	Freq (low byte)							
5	Freq (high byte)							
6	MaxFreq (low byte)							
7	MaxFreq (high byte)							
8	MinFreq (low byte)							
9	MinFreq (high byte)							
10	MaxV (low byte)							
11	MaxV (high byte)							
12	PulsHiPwr (low byte)							
13	PulsHiPwr (high byte)							
14	PulsLoPwr (low byte)							
15	PulsLoPwr (high byte)							
16	PulsRate (low byte)							
17	PulsRate (high byte)							
18	PulsHiTime (low byte)							
19	PulsHiTime (high byte)							
20	RampUp (low byte)							
21	RampUp (high byte)							
22	RampDn (low byte)							
23	RampDn (high byte)							
24	MaxVF (low byte)							

Assembly Set 2: Assembly ID 67hex I/O Poll Response Data Format								
BYTE	7	6	5	4	3	2	1	0
25	MaxVF (high byte)							
26	MinVF (low byte)							
27	MinVF (high byte)							
28	CoarseF (low byte)							
29	CoarseF (high byte)							
30	FineF (low byte)							
31	FineF (low byte)							
32	StrikeF (low byte)							
33	StrikeF (high byte)							
34	(res)							
35	(res)							
36	CtrlMode							
37	PulsDuty							
38	PresetEna							
39	PreTune							
40	PreLoad							
41	CoarseR							
42	FineT							
43	TuneFB							
44	LinkTimer							
45	MatchLoad							
46	MatchTune							
47	(res)							
48	FreqCtrl	PrbPol	Rng5/10	ExcCtrl	RngPwr	Level	RegPV	RFEN
49	FreqTune	MatchConn	RampEna	(res)	PlsMon	PlsSrc	PlsType	PlsEna
50	(res)	(res)	(res)	LinkMon	(res)	(res)	XrfvEna	XimpEna
51	(res)	(res)	(res)	(res)	(res)	(res)	(res)	IGNORE
52	Bits that are set indicate which corresponding bits in Byte 48 may be changed							
53	Bits that are set indicate which corresponding bits in Byte 49 may be changed							
54	Bits that are set indicate which corresponding bits in Byte 50 may be changed							
55	Bits that are set indicate which corresponding bits in Byte 51 may be changed							
56	ICT	ICE	(res)	EXTOK	HDW	TMPOK	CMPOK	RFON
57	UNBAL	DISS	REFLIM	MAXPWR	TEMP	RFON	EXT	RFOK
58	(res)	(res)	(res)	LINK	(res)	XIMP	XRFV	PACLIM
59	(res)	(res)	(res)	(res)	(res)	(res)	(res)	(res)
60	FwdPwr (low byte)							
61	FwdPwr (high byte)							

Assembly Set 2: Assembly ID 67hex I/O Poll Response Data Format								
BYTE	7	6	5	4	3	2	1	0
62	RefPwr (low byte)							
63	RefPwr (high byte)							
64	ProbeDC (low byte)							
65	ProbeDC (high byte)							
66	MatchPhs (low byte)							
67	MatchPhs (high byte)							
68	MatchMag (low byte)							
69	MatchMag (high byte)							

This assembly is sent from the RF Power Supply to the Master, and is used to report the current values of various parameters as follows:

Assembly Set 2: Assembly ID 67hex I/O Poll Response Data	
BYTE	Data Detail
Bytes 0,1	Setpoint - Power or Voltage Setpoint If RegPV=0 and RngPwr=0: value in Watts*10 If RegPV=0 and RngPwr=1: value in Watts If RegPV=1: value in Volts
Bytes 2,3	MaxPwr - Maximum Power, Value in Watts
Bytes 4,5	Freq - RF Output Frequency, Value in KHz
Bytes 6,7	MaxFreq - Maximum Output Frequency, Value in KHz
Bytes 8,9	MinFreq - Minimum Output Frequency, Value in KHz
Bytes 10,11	MaxV - Maximum DC Voltage in Voltage Control, Value in Volts
Bytes 12,13	PulsHiPwr - Pulse High Power (Pulse Type 1), Value in Watts
Bytes 14,15	PulsLoPwr - Pulse Low Power (Pulse Type 1), Value in Watts
Bytes 16,17	PulsRate - Pulse Rate (Pulse Type 0), Value in Hz
Bytes 18,19	PulsHiTime - Pulse High Time (Pulse Type 1), Value in mS
Bytes 20,21	RampUp - Ramp-Up Time, Value in S
Bytes 22,23	RampDn - Ramp-Down Time, Value in S
Bytes 24,25	MaxVF - Maximum Tune Frequency, Value in KHz
Bytes 26,27	MinVF - Minimum Tune Frequency, Value in KHz
Bytes 28,29	CoarseF - Coarse Tune Frequency Step, Value in Hz
Bytes 30,31	FineF - Fine Tune Frequency Step, Value in Hz
Bytes 32,33	StrikeF - Strike Frequency, Value in KHz
Byte 36	CtrlMode - Control Mode 0 = Panel Control 1 = Analog Control 2 = Serial Control

Assembly Set 2: Assembly ID 67hex I/O Poll Response Data	
BYTE	Data Detail
Byte 37	PulsDuty - Pulse Duty Cycle, Value in percent
Byte 38	PresetEna - Preset Mode Enable 0 = disabled 1 = enabled (standard rfok output) 2 = enabled (inverted rfok output)
Byte 39	PreTune - Tune Preset, Value in percent
Byte 40	PreLoad - Load Preset, Value in percent
Byte 41	CoarseR - Coarse Tune Trip Ratio, Value in percent
Byte 42	FineT - Fine Tune Suspension Point, Value in Watts
Byte 43	TuneFB - Tune Feedback Source 0 = reflected power 1 = external phase detector, positive polarity 2 = external phase detector, negative polarity
Byte 44	LinkTimer - Link Loss Detection Timer, Value in Seconds
Byte 45	MatchLoad - Match Load Position, Value in percent
Byte 46	MatchTune - Match Tune Position, Value in percent
Byte 48 bit 7	FreqCtrl - Frequency Control Enable 0 = Disabled 1 = Enabled
Byte 48 bit 6	PrbPol - Probe Polarity 0 = +PRB DB25 (probe inverter disabled) 1 = -PRB BNC (probe inverter enabled)
Byte 48 bit 5	Rng5/10 - Analog Interface Range Select, 5V or 10V 0 = 5V F.S. 1 = 10V F.S.
Byte 48 bit 4	ExcCtrl - Exciter Control 0 = Master 1 = Slave
Byte 48 bit 3	RngPwr - Range Select, Low or High Power 0 = Low Power Range 1 = High Power Range
Byte 48 bit 2	Level - Level Mode 0 = Regulate on forward power 1 = Regulate on forward power - reflected power
Byte 48 bit 1	RegPV - Regulation Type, Power or Voltage 0 = Regulate on power 1 = Regulate on voltage
Byte 48 bit 0	RFEN - RF Off/On Control 0 = RF Off 1 = RF On

Assembly Set 2: Assembly ID 67hex I/O Poll Response Data	
BYTE	Data Detail
Byte 49 bit 7	FreqTune - Frequency Tune Enable 0 = Disabled 1 = Enabled
Byte 49 bit 6	MatchConn - Connect to Match Controller 0 = Do not connect 1 = Connect : send desired match/load positions, report current positions
Byte 49 bit 5	RampEna - Ramping Enable 0 = Disabled 1 = Enabled
Byte 49 bit 3	PlsMon - Pulse Monitor Output (Type 1) 0 = Peak 1 = Real time
Byte 49 bit 2	PlsSrc - Pulse Source 0 = Internal 1 = External
Byte 49 bit 1	PlsType - Pulse Type 0 = Single-level, pulse rate, duty cycle 1 = Dual-level, high time, duty cycle
Byte 49 bit 0	PlsEna - Pulse Enable 0 = Disabled 1 = Enabled
Byte 50 bit 4	LinkMon - Link Loss Monitor Enable 0 = Disabled 1 = Enabled
Byte 50 bit 1	XrfvEna - Excessive RF Voltage Alarm Enable 0 = Disabled 1 = Enabled
Byte 50 bit 0	XimpEna - Excessive Impedance Alarm Enable 0 = Disabled 1 = Enabled
Byte 51 bit 0	IGNORE - Ignore All Parameters in I/O Poll Response 0 = Values in I/O Poll Response are valid 1 = Ignore all values in the I/O Poll Response
Byte 52	Bits that are set in this byte indicate which bits in Byte 48 can be set.
Byte 53	Bits that are set in this byte indicate which bits in Byte 49 can be set.
Byte 54	Bits that are set in this byte indicate which bits in Byte 50 can be set.
Byte 55	Bits that are set in this byte indicate which bits in Byte 51 can be set.
Byte 56 bit 7	ICT - Internal Communication Timeout 1 = RF Power Supply CPU not responding (Mod LED red)
Byte 56 bit 6	ICE - Internal Communication Error 1 = Error detected in data received from Generator CPU

Assembly Set 2: Assembly ID 67hex I/O Poll Response Data	
BYTE	Data Detail
Byte 56 bit 4	EXTOK - External Interlock OK 0 = Interlock not detected (alarm) 1 = Interlock detected
Byte 56 bit 3	HDW - Hardware Fault 1 = RF Power Supply not operating properly (Mod LED red)
Byte 56 bit 2	TMPOK - Temperature OK 0 = Temperature alarm 1 = Temperature OK
Byte 56 bit 1	CMPOK - Compliance 0 = Output has not yet reached the setpoint 1 = Setpoint reached
Byte 56 bit 0	RFON - RF ON 0 = RF Off 1 = RF On
Byte 57 bit 7	UNBAL - Unbalanced 0 = Amplifier currents are balanced 1 = Amplifier currents not balanced
Byte 57 bit 6	DISS - Regulating on Dissipation Setpoint 0 = Not regulating on dissipation setpoint 1 = Regulating on dissipation setpoint
Byte 57 bit 5	REFLIM - Reflected Power Limit 0 = No alarm 1 = Alarm: reflected power limit
Byte 57 bit 4	MAXPWR - Maximum Power Limit 0 = No alarm 1 = Alarm: maximum power output
Byte 57 bit 3	TEMP - Temperature 0 = No alarm 1 = Alarm: temperature limit exceeded
Byte 57 bit 2	RFON 0 = RF Off 1 = RF On
Byte 57 bit 1	EXT - External Interlock 0 = No alarm 1 = Interlock not detected
Byte 57 bit 0	RFOK 0 = RF is Off, or RF is On and reflected power limit reached 1 = RF on and reflected power is below the limit
Byte 58 bit 2	XIMP - Excessive Impedance 0 = No alarm 1 = Excessive impedance detected

Assembly Set 2: Assembly ID 67hex I/O Poll Response Data	
BYTE	Data Detail
Byte 58 bit 1	XRFV - Excessive RF Voltage 0 = No alarm 1 = Excessive RF voltage detected
Byte 58 bit 0	PACLIM - PA Current Limit 0 = No alarm 1 = Current limit reached
Bytes 60,61	FwdPwr - Forward Power If RngPwr=0: value in Watts*10 If RngPwr=1: value in Watts
Bytes 62,63	RefPwr - Reflected Power If RngPwr=0: value in Watts*10 If RngPwr=1: value in Watts
Bytes 64,65	ProbeDC - DC Voltage in Voltage Control (value in Volts)
Bytes 66,67	Match Phase (value in mV)
Bytes 68,69	Match Magnitude (value in mV)

Assembly Set 3: I/O Poll Command Format - Assembly ID 68hex

From Fieldbus To RF Power Supply. This assembly is sent from the Master to the RF Power Supply, and is used to set various parameters as follows:

Assembly Set 3: Assembly ID 68hex Commands / Parameters Format								
BYTE	7	6	5	4	3	2	1	0
0	Setpoint (low byte)							
1	Setpoint (high byte)							
2	Freq (low byte)							
3	Freq (high byte)							
4	PulsHiPwr (low byte)							
5	PulsHiPwr (high byte)							
6	PulsLoPwr (low byte)							
7	PulsLoPwr (high byte)							
8	PulsRate (low byte)							
9	PulsRate (high byte)							
10	PulsHiTime (low byte)							
11	PulsHiTime (high byte)							
12	RampUp (low byte)							
13	RampUp (high byte)							
14	RampDn (low byte)							
15	RampDn (high byte)							
16	CoarseF (low byte)							
17	CoarseF (high byte)							
18	FineF (low byte)							
19	FineF (low byte)							
20	StrikeF (low byte)							
21	StrikeF (high byte)							
22	CtrlMode							
23	PulsDuty							
24	CoarseR							
25	FineT							
26	FreqCtrl	PrbPol	Rng5/10	ExcCtrl	RngPwr	Level	RegPV	RFEN
27	FreqTune	(res)	RampEna	(res)	PlsMon	PlsSrc	(res)	PlsEna
28	(res)	(res)	(res)	LinkMon	(res)	(res)	XrfvEna	XimpEna
29	(res)	(res)	(res)	(res)	(res)	(res)	(res)	IGNORE

This assembly is sent from the Master to the RF Power Supply, and is used to set various parameters as follows:

Assembly Set 3: Assembly ID 68hex Commands / Parameters	
BYTE	Command / Parameter Detail
Bytes 0,1	Setpoint - Power or Voltage Setpoint If RegPV=0 and RngPwr=0: value in Watts*10, min = 0, max = MaxPwr If RegPV=0 and RngPwr=1: value in Watts, min = 0, max = MaxPwr If RegPV=1: value in Volts, min = 0, max = MaxV
Bytes 2,3	Freq - Generator Output Frequency Value in KHz, min = MinFreq, max = MaxFreq
Bytes 4,5	PulsHiPwr - Pulse High Power (Pulse Type 1) Value in Watts, min = 0, max = MaxPwr
Bytes 6,7	PulsLoPwr - Pulse Low Power (Pulse Type 1) Value in Watts, min = 0, max = MaxPwr
Bytes 8,9	PulsRate - Pulse Rate (Pulse Type 0) Value in Hz, min = 1, max = 10000
Bytes 10,11	PulsHiTime - Pulse High Time (Pulse Type 1) Value in mS, min = 1, max = 9999
Bytes 12,13	RampUp - Ramp-Up Time Value in S, min = 1, max = 9999
Bytes 14,15	RampDn - Ramp-Down Time Value in S, min = 1, max = 9999
Bytes 16,17	CoarseF - Coarse Tune Frequency Step Value in Hz, min = 1, max = 30000
Bytes 18,19	FineF - Fine Tune Frequency Step Value in Hz, min = 1, max = 30000
Bytes 20,21	StrikeF - Strike Frequency Value in KHz, min = MinVF, max = MaxVF
Byte 22	CtrlMode - Control Mode 0 = Panel Control 1 = Analog Control 2 = Serial Control
Byte 23	PulsDuty - Pulse Duty Cycle Value in percent, min = 0, max = 100
Byte 24	CoarseR - Coarse Tune Trip Ratio Value in percent, min = 1, max = 100
Byte 25	FineT - Fine Tune Suspension Point Value in Watts, min = 1, max = 100
Byte 26 bit 7	FreqCtrl - Frequency Control Enable 0 = Disabled 1 = Enabled

Assembly Set 3: Assembly ID 68hex Commands / Parameters	
BYTE	Command / Parameter Detail
Byte 26 bit 6	PrbPol - Probe Polarity 0 = +PRB DB25 (probe inverter disabled) 1 = -PRB BNC (probe inverter enabled)
Byte 26 bit 5	Rng5/10 - Analog Interface Range Select, 5V or 10V 0 = 5V F.S. 1 = 10V F.S.
Byte 26 bit 4	ExcCtrl - Exciter Control 0 = Master 1 = Slave
Byte 26 bit 3	RngPwr - Range Select, Low or High Power 0 = Low Power Range 1 = High Power Range
Byte 26 bit 2	Level - Level Mode 0 = Regulate on forward power 1 = Regulate on forward power - reflected power
Byte 26 bit 1	RegPV - Regulation Type, Power or Voltage 0 = Regulate on power 1 = Regulate on voltage
Byte 26 bit 0	RFEN - RF Off/On Control 0 = RF Off 1 = RF On
Byte 27 bit 7	FreqTune - Frequency Tune Enable 0 = Disabled 1 = Enabled
Byte 27 bit 5	RampEna - Ramping Enable 0 = Disabled 1 = Enabled
Byte 27 bit 3	PlsMon - Pulse Monitor Output (Type 1) 0 = Peak 1 = Real time
Byte 27 bit 2	PlsSrc - Pulse Source 0 = Internal 1 = External
Byte 27 bit 0	PlsEna - Pulse Enable 0 = Disabled 1 = Enabled
Byte 28 bit 4	LinkMon - Link Loss Monitor Enable 0 = Disabled 1 = Enabled
Byte 28 bit 1	XrfvEna - Excessive RF Voltage Alarm Enable 0 = Disabled 1 = Enabled

Assembly Set 3: Assembly ID 68hex Commands / Parameters	
BYTE	Command / Parameter Detail
Byte 28 bit 0	XimpEna - Excessive Impedance Alarm Enable 0 = Disabled 1 = Enabled
Byte 29 bit 0	IGNORE - Ignore All Parameters in I/O Poll Command 0 = Process all parameters in the I/O Poll Command 1 = Ignore all parameters in the I/O Poll Command Use this when only the I/O Poll Response is desired.

Assembly Set 3: I/O Poll Response Format - Assembly ID 69hex

From RF Power Supply To Fieldbus. This assembly is sent from the RF Power Supply to the Master, and is used to report the current values of various parameters as follows:

Assembly Set 3: Assembly ID 69hex I/O Poll Response Data Format								
BYTE	7	6	5	4	3	2	1	0
0	Freq (low byte)							
1	Freq (high byte)							
2	PulsHiPwr (low byte)							
3	PulsHiPwr (high byte)							
4	PulsLoPwr (low byte)							
5	PulsLoPwr (high byte)							
6	PulsRate (low byte)							
7	PulsRate (high byte)							
8	PulsHiTime (low byte)							
9	PulsHiTime (high byte)							
10	RampUp (low byte)							
11	RampUp (high byte)							
12	RampDn (low byte)							
13	RampDn (high byte)							
14	CoarseF (low byte)							
15	CoarseF (high byte)							
16	FineF (low byte)							
17	FineF (high byte)							
18	StrikeF (low byte)							
19	StrikeF (high byte)							
20	PulsDuty							
21	CoarseR							

Assembly Set 3: Assembly ID 69hex I/O Poll Response Data Format								
BYTE	7	6	5	4	3	2	1	0
22	FineT							
23	FreqCtrl	PrbPol	Rng5/10	ExcCtrl	RngPwr	Level	RegPV	RFEN
24	FreqTune	(res)	RampEna	(res)	PlsMon	PlsSrc	PlsType	PlsEna
25	(res)	(res)	(res)	LinkMon	(res)	(res)	XrfvEna	XimpEna
26	(res)	(res)	(res)	(res)	(res)	(res)	(res)	IGNORE
27	ICT	ICE	(res)	EXTOK	HDW	TMPOK	CMPOK	RFON
28	UNBAL	DISS	REFLIM	MAXPWR	TEMP	RFON	EXT	RFOK
29	(res)	(res)	(res)	LINK	(res)	XIMP	XRFV	PACLIM
30	FwdPwr (low byte)							
31	FwdPwr (high byte)							
32	RefPwr (low byte)							
33	RefPwr (high byte)							
34	ProbeDC (low byte)							
35	ProbeDC (high byte)							

This assembly is sent from the RF Power Supply to the Master, and is used to report the current values of various parameters as follows:

Assembly Set 3: Assembly ID 69hex I/O Poll Response Data	
BYTE	Data Detail
Bytes 0,1	Freq - Generator Output Frequency, Value in KHz
Bytes 2,3	PulsHiPwr - Pulse High Power (Pulse Type 1), Value in Watts
Bytes 4,5	PulsLoPwr - Pulse Low Power (Pulse Type 1), Value in Watts
Bytes 6,7	PulsRate - Pulse Rate (Pulse Type 0), Value in Hz
Bytes 8,9	PulsHiTime - Pulse High Time (Pulse Type 1), Value in mS
Bytes 10,11	RampUp - Ramp-Up Time, Value in S
Bytes 12,13	RampDn - Ramp-Down Time, Value in S
Bytes 14,15	CoarseF - Coarse Tune Frequency Step, Value in Hz
Bytes 16,17	FineF - Fine Tune Frequency Step, Value in Hz
Bytes 18,19	StrikeF - Strike Frequency, Value in KHz
Byte 20	PulsDuty - Pulse Duty Cycle, Value in percent
Byte 21	CoarseR - Coarse Tune Trip Ratio, Value in percent
Byte 22	FineT - Fine Tune Suspension Point, Value in Watts
Byte 23 bit 7	FreqCtrl - Frequency Control Enable 0 = Disabled 1 = Enabled

Assembly Set 3: Assembly ID 69hex I/O Poll Response Data	
BYTE	Data Detail
Byte 23 bit 6	PrbPol - Probe Polarity 0 = +PRB DB25 (probe inverter disabled) 1 = -PRB BNC (probe inverter enabled)
Byte 23 bit 5	Rng5/10 - Analog Interface Range Select, 5V or 10V 0 = 5V F.S. 1 = 10V F.S.
Byte 23 bit 4	ExcCtrl - Exciter Control 0 = Master 1 = Slave
Byte 23 bit 3	RngPwr - Range Select, Low or High Power 0 = Low Power Range 1 = High Power Range
Byte 23 bit 2	Level - Level Mode 0 = Regulate on forward power 1 = Regulate on forward power - reflected power
Byte 23 bit 1	RegPV - Regulation Type, Power or Voltage 0 = Regulate on power 1 = Regulate on voltage
Byte 23 bit 0	RFEN - RF Off/On Control 0 = RF Off 1 = RF On
Byte 24 bit 7	FreqTune - Frequency Tune Enable 0 = Disabled 1 = Enabled
Byte 24 bit 5	RampEna - Ramping Enable 0 = Disabled 1 = Enabled
Byte 24 bit 3	PlsMon - Pulse Monitor Output (Type 1) 0 = Peak 1 = Real time
Byte 24 bit 2	PlsSrc - Pulse Source 0 = Internal 1 = External
Byte 24 bit 1	PlsType - Pulse Type 0 = Single-level, pulse rate, duty cycle 1 = Dual-level, high time, duty cycle
Byte 24 bit 0	PlsEna - Pulse Enable 0 = Disabled 1 = Enabled
Byte 25 bit 4	LinkMon - Link Loss Monitor Enable 0 = Disabled 1 = Enabled

Assembly Set 3: Assembly ID 69hex I/O Poll Response Data	
BYTE	Data Detail
Byte 25 bit 1	XrfvEna - Excessive RF Voltage Alarm Enable 0 = Disabled 1 = Enabled
Byte 25 bit 0	XimpEna - Excessive Impedance Alarm Enable 0 = Disabled 1 = Enabled
Byte 26 bit 0	IGNORE - Ignore All Parameters in I/O Poll Response 0 = Values in I/O Poll Response are valid 1 = Ignore all values in the I/O Poll Response
Byte 27 bit 7	ICT - Internal Communication Timeout 1 = RF Power Supply CPU not responding (Mod LED red)
Byte 27 bit 6	ICE - Internal Communication Error 1 = Error detected in data received from RF Power Supply CPU
Byte 27 bit 4	EXTOK - External Interlock OK 0 = Interlock not detected (alarm) 1 = Interlock detected
Byte 27 bit 3	HDW - Hardware Fault 1 = RF Power Supply not operating properly (Mod LED red)
Byte 27 bit 2	TMPOK - Temperature OK 0 = Temperature alarm 1 = Temperature OK
Byte 27 bit 1	CMPOK - Compliance 0 = Output has not yet reached the setpoint 1 = Setpoint reached
Byte 27 bit 0	RFON - RF ON 0 = RF Off 1 = RF On
Byte 28 bit 7	UNBAL - Unbalanced 0 = Amplifier currents are balanced 1 = Amplifier currents not balanced
Byte 28 bit 6	DISS - Regulating on Dissipation Setpoint 0 = Not regulating on dissipation setpoint 1 = Regulating on dissipation setpoint
Byte 28 bit 5	REFLIM - Reflected Power Limit 0 = No alarm 1 = Alarm: reflected power limit
Byte 28 bit 4	MAXPWR - Maximum Power Limit 0 = No alarm 1 = Alarm: maximum power output

Assembly Set 3: Assembly ID 69hex I/O Poll Response Data	
BYTE	Data Detail
Byte 28 bit 3	TEMP - Temperature 0 = No alarm 1 = Alarm: temperature limit exceeded
Byte 28 bit 2	RFON 0 = RF Off 1 = RF On
Byte 28 bit 1	EXT - External Interlock 0 = No alarm 1 = Interlock not detected
Byte 28 bit 0	RFOK 0 = RF is Off, or RF is On and reflected power limit reached 1 = RF on and reflected power is below the limit
Byte 29 bit 2	XIMP - Excessive Impedance 0 = No alarm 1 = Excessive impedance detected
Byte 29 bit 1	XRFV - Excessive RF Voltage 0 = No alarm 1 = Excessive RF voltage detected
Byte 29 bit 0	PACLIM - PA Current Limit 0 = No alarm 1 = Current limit reached
Bytes 30,31	FwdPwr - Forward Power If RngPwr=0: value in Watts*10 If RngPwr=1: value in Watts
Bytes 32,33	RefPwr - Reflected Power If RngPwr=0: value in Watts*10 If RngPwr=1: value in Watts
Bytes 34,35	ProbeDC - DC Voltage in Voltage Control (value in Volts)

DeviceNet Product Codes and Product Names

Each model in the R/LX01-Series of RF power Supplies has its own Product Code and Product Name. The Product Code is a 16-bit integer, and the Product Name is a 16-character ASCII string. These parameters are included in the Identity Object and can be obtained via DeviceNet using the Get Attribute Single request.

Product Code	Product Name
101	"Seren IPS R301 "
102	"Seren IPS R601 "
103	"Seren IPS R1001 "
104	"Seren IPS R2001 "
105	"Seren IPS R3001 "
106	"Seren IPS R5001 "
107	"Seren IPS R10001"
108	"Seren IPS R15001"
201	"Seren IPS L301 "
202	"Seren IPS L601 "
203	"Seren IPS L1001 "
204	"Seren IPS L2001 "
205	"Seren IPS L3001 "
206	"Seren IPS L5001 "

DeviceNet Serial Number Reporting

The RF Power Supply serial number on file at the factory consists of the RF Power Supply model name followed by a 4-digit sequence number. For example, an R5001 may have a serial number of R5001-0655.

When the serial number is reported via DeviceNet, it is a 32-bit integer which, when shown as a decimal value, consists of the Product Code and the last 4 digits of the factory serial number. For example, if the factory serial number is R5001-0655, the DeviceNet serial number is 1060655.

DeviceNet Electronic Data Sheet (EDS)

An EDS (Electronic Data Sheet) is available.

A copy of the EDS (Electronic Data Sheet) is included on the Seren IPS Product Information CD-ROM, supplied with the RF Power Supply. See the "Manual Directory - ReadMe.PDF" file on the Seren IPS Product Information CD-ROM for EDS file location information.

A current copy of the EDS can also be obtained by contacting your Seren IPS dealer or Seren IPS Technical Support.

With Generator firmware 11.3W02 and above, the EDS is distributed as a text file named Seren-EDS-RFGEN-ApB-YYYYMMDD.txt, where:

ApB Is the file revision level. Example 3p5 = Revision 3.5
 YYYYMMDD Is the file date in Year/Month/Day format.

Note: It may be necessary to change ProdCode and ProdName values to match those of the particular model of RF Power Supply. The ProdCode and ProdName are described on the previous page of this document.

The contents of the EDS file is listed below:

```
[File]
DescText = "EDS File for RF Generators from Seren IPS";
CreateDate = 08-11-2006;
CreateTime = 00:00:00;
ModDate = 07-19-2007;
ModTime = 00:00:00;
Revision = 3.5;

[Device]
VendCode = 946;
VendName = "Seren IPS Inc.";
ProdType = 32;
ProdTypeStr = "RF Power Generator";
ProdCode = 101; $ Depends on model. 101 = R301. See manual.
MajRev = 3; $ Device Major Revision
MinRev = 5; $ Device Minor Revision
ProdName = "Seren IPS mmmmmm"; $ mmmmmm = model such as R301.
Catalog = "R/L Series";

[IO_Info]
Default = 0x0001; $ Poll Only
PollInfo=
0x0001, $ Poll
1, $ Default Input = Input1
1; $ Default Output = Output1
$ -- Input Connections --
Input1=
9, $ 9 bytes
```

```

0, $ All bits are significant
0x0001, $ Poll Connection
"Forward Power + Reflected Power + Status", $ Name String
6, $ Path Size
"20 04 24 65 30 03", $ Assy Obj Inst 65 Attr 3
"See Seren documentation."; $ Help String
Input2=
70, $ 70 bytes
0, $ All bits are significant
0x0001, $ Poll Connection
"Reports settings, power readings, status", $ Name String
6, $ Path Size
"20 04 24 67 30 03", $ Assy Obj Inst 67 Attr 3
"See Seren documentation."; $ Help String
Input3=
36, $ 36 bytes
0, $ All bits are significant
0x0001, $ Poll Connection
"Reports settings, power readings, status", $ Name String
6, $ Path Size
"20 04 24 69 30 03", $ Assy Obj Inst 69 Attr 3
"See Seren documentation."; $ Help String
$ -- Output Connections --
Output1=
5, $ 5 bytes
0, $ All bits are significant
0x0001, $ Poll Connection
"Power Setpoint + Output On/Off", $ Name String
6, $ Path Size
"20 04 24 64 30 03", $ Assy Obj Inst 64 Attr 3
"See Seren documentation."; $ Help String
Output2=
52, $ 52 bytes
0, $ All bits are significant
0x0001, $ Poll Connection
"Output On/Off and all other settings", $ Name String
6, $ Path Size
"20 04 24 66 30 03", $ Assy Obj Inst 66 Attr 3
"See Seren documentation."; $ Help String
Output3=
30, $ 30 bytes
0, $ All bits are significant
0x0001, $ Poll Connection
"Output On/Off, other settings", $ Name String
6, $ Path Size
"20 04 24 68 30 03", $ Assy Obj Inst 68 Attr 3
"See Seren documentation."; $ Help String

```

How to Configure the RF Power Supply for DeviceNet Communications

1. Disable the RF Power Supply's AC Mains power.
2. If the RF Power Supply has DeviceNet configuration switches on the rear panel as shown in Figure 1 below, set the desired address (00 - 63) and data rate (125, 250, or 500 kbit/sec). In Figure 1, the address is set to 63 and the data rate is set to 500 kbit/sec.

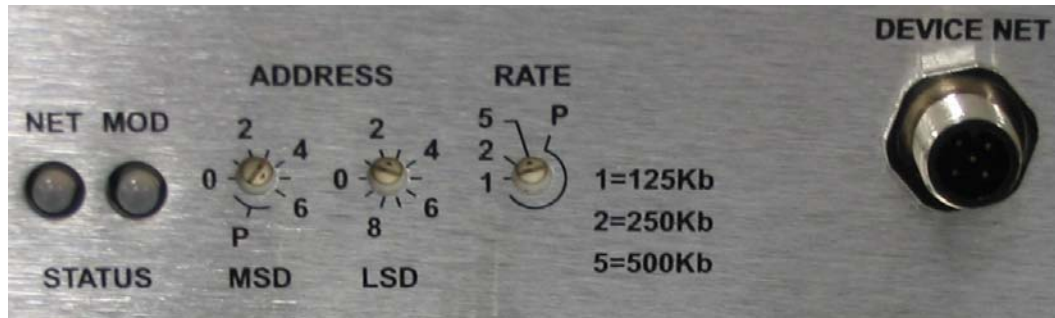

Figure 1. DeviceNet Rear Panel Indicators, Switches, and Connector

3. Enable the RF power Supply's AC Mains Power. The display should appear similar to this:

SET: 0W	REF: 0W
SERIAL PWR	MST EXT
PGM	DOWN UP ENT

4. Press the PGM softkey. The front panel display should appear similar to this:

SET: 0W	REF: 0W
SERIAL PWR	MST EXT
SERIAL CONTROL	
PGM	DOWN UP ENT

The third line of the display should read PANEL CONTROL, ANALOG CONTROL, or SERIAL CONTROL. If not, press the DOWN softkey until it does.

If the display does not say "SERIAL CONTROL", press the up-arrow key until it does. Press the ENT softkey to save the selection.

5. Press the DOWN softkey. The front panel display should appear similar to this:

SET: 0W	REF: 0W		
SERIAL PWR	MST	EXT	
DEVICENET			
PGM	DOWN	UP	ENT

If the display does not say "DEVICENET", press up-arrow or down-arrow until it does. Press the ENT softkey to save the selection.

6. Press the DOWN softkey. The front panel display should appear similar to this:

SET: 0W	REF: 0W		
SERIAL PWR	MST	EXT	
ADDRESS #		63	
PGM	DOWN	UP	ENT

Use the up-arrow and down-arrow buttons to set the address, then press the ENT softkey. If the RF Power Supply has DeviceNet address switches on the rear panel, the switches will override the front panel setting unless the address switches are set to 64 or higher. It is strongly recommended that the front panel address setting match the rear panel address switch settings.

7. Press the DOWN softkey. The front panel display should appear similar to this:

SET: 0W	REF: 0W		
SERIAL PWR	MST	EXT	
DATA RATE		500 KBPS	
PGM	DOWN	UP	ENT

Use the up-arrow and down-arrow buttons to set the data rate, then press the ENT softkey. If the RF Power Supply has a DeviceNet rate switch on the rear panel, the switch will override the front panel setting unless the switch is set to the "P" position. It is strongly recommended that the front panel data rate setting match the rear panel data rate switch setting.

8. Press the DOWN softkey. The front panel display should appear similar to this:

SET: 0W	REF: 0W
SERIAL PWR	MST EXT
DN Data 5 out 9 in	
PGM DOWN	UP ENT

Use up-arrow and down-arrow buttons to select the desired Assembly Set, then press the ENT softkey to save the selection.

DN Data 5 out 9 in	(Assembly Set 1)
DN Data 52 out 70 in	(Assembly Set 2)
DN Data 30 out 36 in	(Assembly Set 3)

9. Press the UP softkey twice. The front panel display should appear similar to this:

SET: 0W	REF: 0W
SERIAL PWR	MST EXT
DEVICENET	
PGM DOWN	UP ENT

10. Press the ENT softkey. The RF Power Supply will restart.
11. Disable the RF Power Supply's AC Mains power
12. Connect the user-supplied DeviceNet cable.
13. Enable the RF Power Supply's AC Mains Power. If the RF Power Supply is equipped with DeviceNet status indicators on the rear panel, the indicator LEDs should light up in the following sequence:

DeviceNet Status Indicator LED Power-On Sequence		
Sequence	NET LED	MOD LED
1	Flashes GREEN briefly (normal turn-on behavior)	Flashes GREEN briefly (normal turn-on behavior)
2	OFF	GREEN
3	OFF	RED
4	GREEN	GREEN
5	RED	GREEN
6	OFF	OFF
7	AMBER	AMBER
8	OFF	OFF

DeviceNet Operation

If the RF Power Supply has DeviceNet status indicator LEDs on the rear panel, they will light up in the sequence described in step 13 above when the unit is powered-on. Once the power-on sequence is complete, the MOD indicator should stay off. The NET indicator should either be flashing green (waiting for connection) or solid green (connection established).

If the NET indicator LED is red, perform the following checks:

- Ensure there is proper power available on the DeviceNet network.
- Verify the DeviceNet network is properly terminated.
- Confirm the RF Power Supply's address and data rate settings are valid and the DeviceNet address is not duplicated elsewhere on the DeviceNet network.

If both LED indicators stay amber:

Verify the serial mode is set to **DEVICENET**.

If the RF Power Supply does not have DeviceNet status indicators on the rear panel, a DeviceNet status message should appear on the third line of the front panel display. Examples:

DN63/500 CHK DN CARD
DN63/500 COMM ERROR
DN63/500 No Master
DN63/500 On-Line

The number following the "DN" is the DeviceNet address, which can be 0-63. The number following the slash is the DeviceNet data rate, which can be 125, 250, or 500 kbits/sec.

The operational status of the DeviceNet communications interface is described in the message next to the displayed DeviceNet Address and Data Rate (DNXX/YYY)

Front Panel DeviceNet Status Message	
Message	DeviceNet Operational Status & Corrective Measures
CHK DN CARD	The internal DeviceNet Interface Card is not responding
COMM ERROR	Communications Error <ol style="list-style-type: none"> 1. Ensure there is proper power available on the DeviceNet network. 2. Verify the DeviceNet network is properly terminated 3. Confirm the RF Power Supply's address and data rate settings are valid and the DeviceNet address is not duplicated elsewhere on the DeviceNet network.
No Master	The unit is waiting to be contacted by a DeviceNet Master.
On-Line	The unit is under the control of a DeviceNet Master

Pulsing Operation

Most RF Power Supplies in the Seren IPS Inc. RX01/LX01 series support pulsing. Pulsing is a regularly repeating change in the output power such that the output alternates between two power levels. The pulse timing is controlled by a "Gate" signal, either generated by an internal timing circuit or from an external logic signal applied to Pin 7 (the GATE input) of the Analog Interface connector.

There are two distinct types of pulsing available, referred to as *Pulse Type 0* and *Pulse Type 1*. The two pulsing types differ in the circuitry used to control the output power and in the settings available to determine the output levels and timing parameters. Each RF Power Supply is configured for either Pulse Type 0 or Pulse Type 1 when it is manufactured. A unit with one type of pulsing cannot be changed to the other type unless it is returned to the factory. Type 0 pulsing is standard on most models.

Note: When pulsing is turned off, the output of the RF Power Supply is maintained at a constant level. This is referred to as "*CW*" or *continuous wave* operation.

Pulse Type 0 - Single-Level, High-Speed

With Pulse Type 0, RF output power alternates between the power setpoint (the same setpoint used for CW operation) and zero Watts. Alternately connecting and disconnecting the internal "exciter" signal to the RF Power Supply's power amplifier creates the pulsing effect. When the Gate signal (internal or external) is at a logic high level, the exciter signal is connected and the output power is determined by the setpoint; when the Gate signal is at a logic low level, the exciter is disconnected and the output power is zero.

The following table lists the parameters used to control the pulse timing and power output:

PARAMETERS - PULSE TYPE 0		
Front Panel	Serial Command	Description
PULSE MODE OFF	-P	Disable pulsing
PULSE MODE ON	+P	Enable pulsing
FREQUENCY xxxxxHZ	xxxxx_PR	Select the pulsing rate in Hz
DUTY CYCLE xxx%	xx_D	Select the pulse duty cycle
PULSE GATE INTERNAL	(none)	Select internal pulse timing
PULSE GATE EXTERNAL	(none)	Select external pulse timing
(RUN mode, use up/down arrows)	xxxx_W	Select the output power setpoint

Definitions of the parameters are provided below along with examples.

The minimum High Time (duration of the non-zero portion of the pulse) is typically 50us (10us with special order). When the external Gate signal is used, the time between transitions of the Gate signal should be at least as long as the specified minimum High Time.

The circuit that regulates the output power level for Pulse Type 0 is optimized for pulse rates of 1000 Hz and above. Please consult the factory if lower pulse rates are required.

Pulse Type 1 - Dual-Level, Low Speed

With Pulse Type 1, RF output power alternates between the High Power setpoint and the Low Power setpoint (the setpoint used for CW operation is not used). The pulsing effect is achieved by adjusting the amplitude of the internal "exciter" signal fed to the RF Power Supply's power amplifier. When the Gate signal (internal or external) is at a logic level high, the exciter signal is adjusted so the RF output power is at the High Power setpoint; when the Gate signal is low, the exciter signal is adjusted so the RF output power is at the Low Power setpoint.

Pulse Type 1 is intended for pulsing applications that require low pulse repetition rates (less than 1000 pulses per second) as well as the possibility of alternating between two non-zero power levels. When external timing is selected, the time between transitions of the Gate signal should be at least 1ms.

The following table lists the parameters used to control the pulse timing and power output:

PARAMETERS – TYPE 1 PULSING		
Front Panel	Serial Command	Description
PULSE MODE OFF	-P	Disable pulsing
PULSE MODE ON	+P	Enable pulsing
ENTER HI PWR xxxxW	xxxx_HP	Select the High Power setpoint
ENTER LO PWR xxxxW	xxxx_LP	Select the Low Power setpoint
HIGH TIME xxxMS	xxxx_HT	Select the High Time in ms
DUTY CYCLE xxx%	xx_D	Select the pulse duty cycle
PULSE GATE INTERNAL	(none)	Select internal pulse timing
PULSE GATE EXTERNAL	(none)	Select external pulse timing
(RUN mode, use up/down arrows)	xxxx_W	Select the output power setpoint

Definitions of the parameters are provided below along with examples.

Pulse Timing Parameters

Definitions:

Pulse Rate	The number of times each second that the pulse pattern is repeated
Pulse Period	The time occupies by one repetition of the pulse pattern
High Time	The time occupied by the non-zero or High Power portion of the pattern
Low Time	The time occupied by the zero-power or Low Power portion of the pattern
Duty Cycle	Ratio of High Time to Pulse Period, expressed in percent

Relations:

Pulse Period	=	1/(Pulse Rate)
Pulse Rate	=	1/(Pulse Period)
High Time	=	(Pulse Period)(Duty Cycle)/100
		Example: If Pulse Period = 10ms and Duty Cycle = 15%, High Time = 1.5ms
Pulse Period	=	(High Time)(100)/(Duty Cycle)
		Example: If High Time = 35ms and Duty Cycle = 10%, Pulse Period = 350ms
Duty Cycle	=	(High Time)(100)/(Pulse Period)
		Example: If High Time = 10ms and Pulse Period = 40ms, Duty Cycle = 25%

Pulse Timing Examples

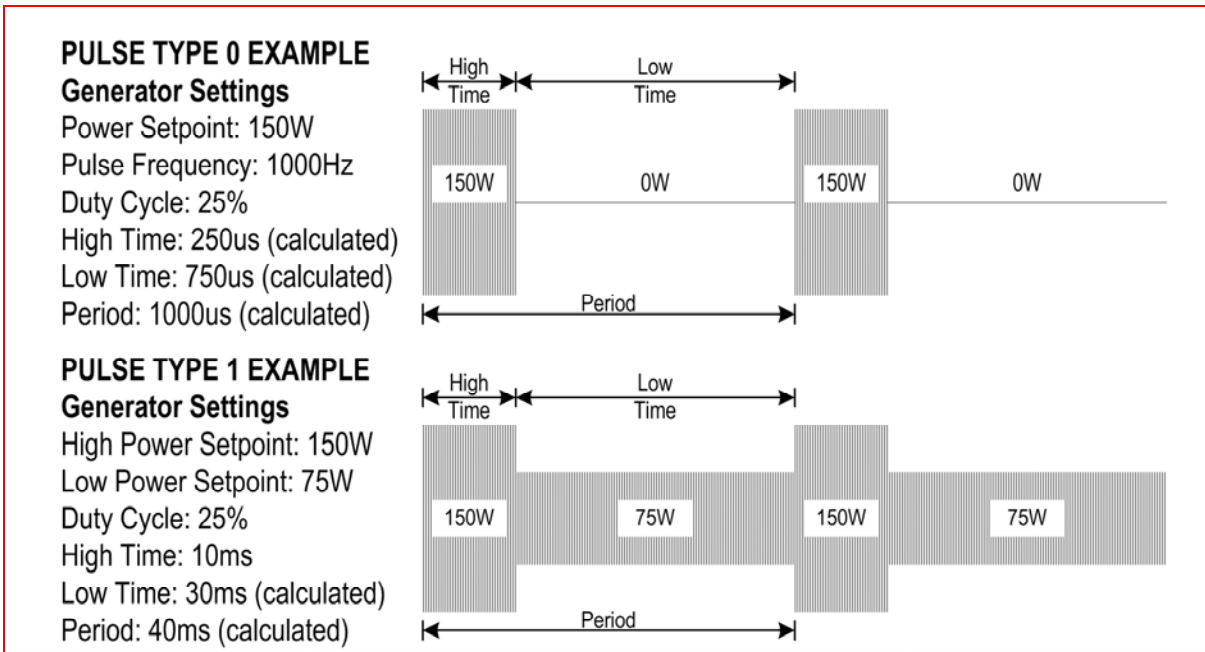

Rear Panel Controls and Connections

Models R101, R101MKII, R301, R301MKII, L301, L101MKII, L301MKII:

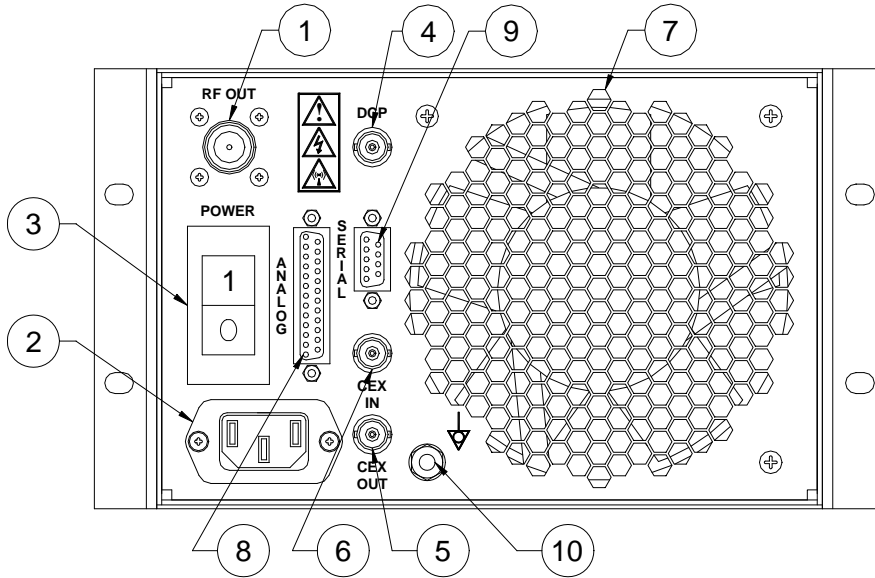

Models R601, L601, R1001, L1001

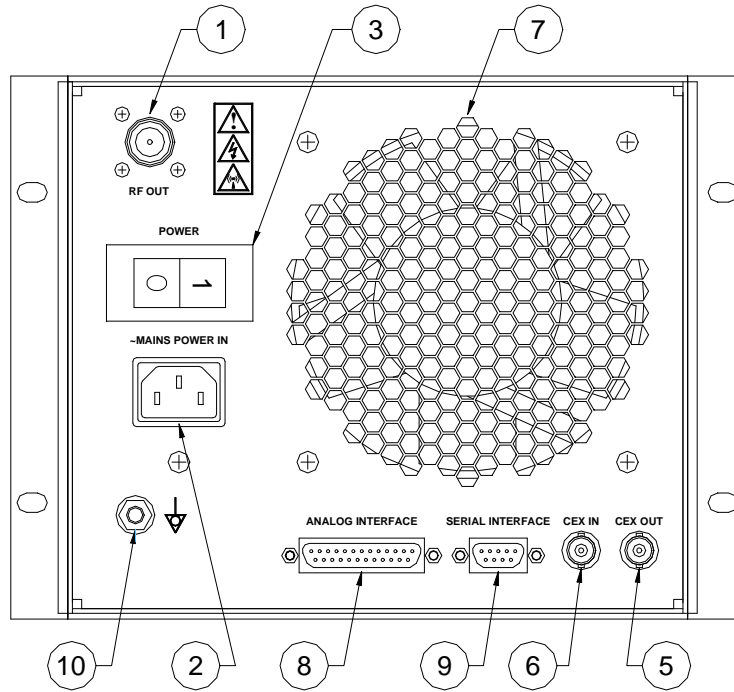

Model R1001W, L1001W

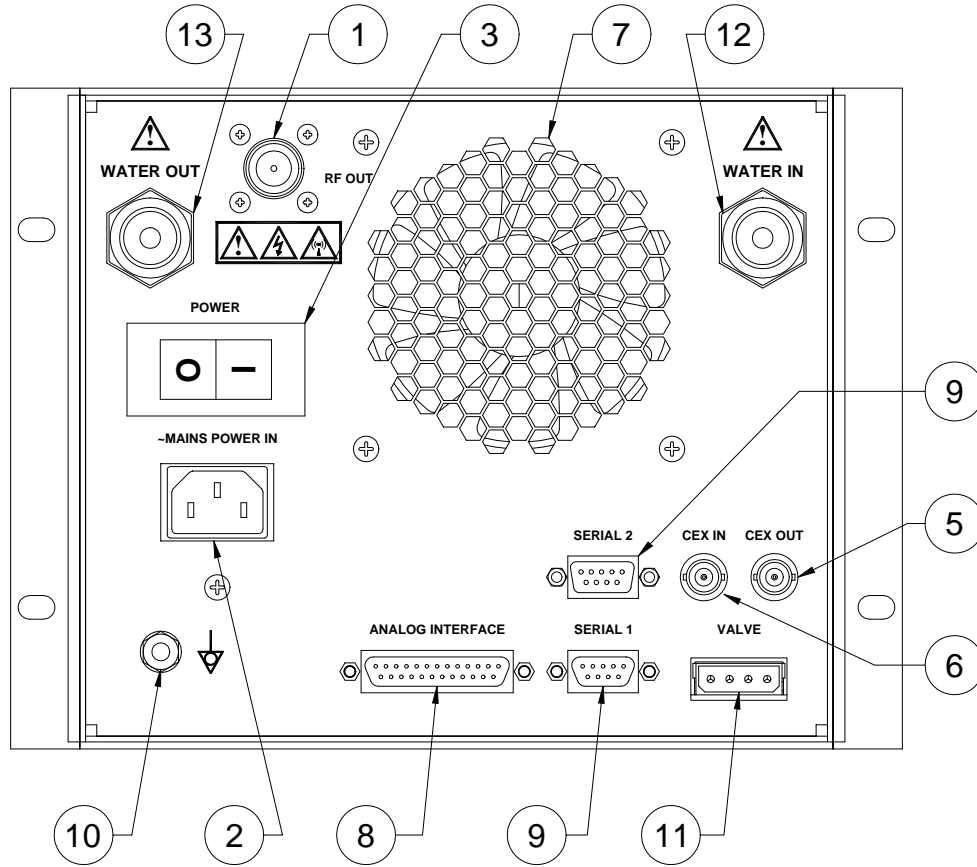

Models R2001, R2001H, L2001, L2001H, R3001, L3001

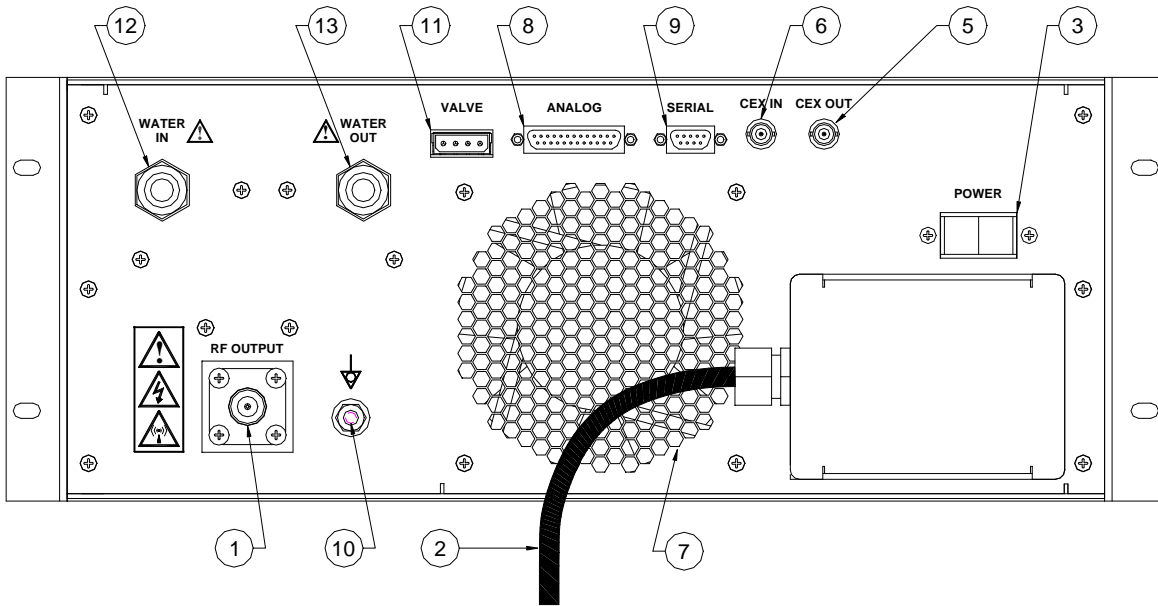

Models R4001, R5001 (4U Package)

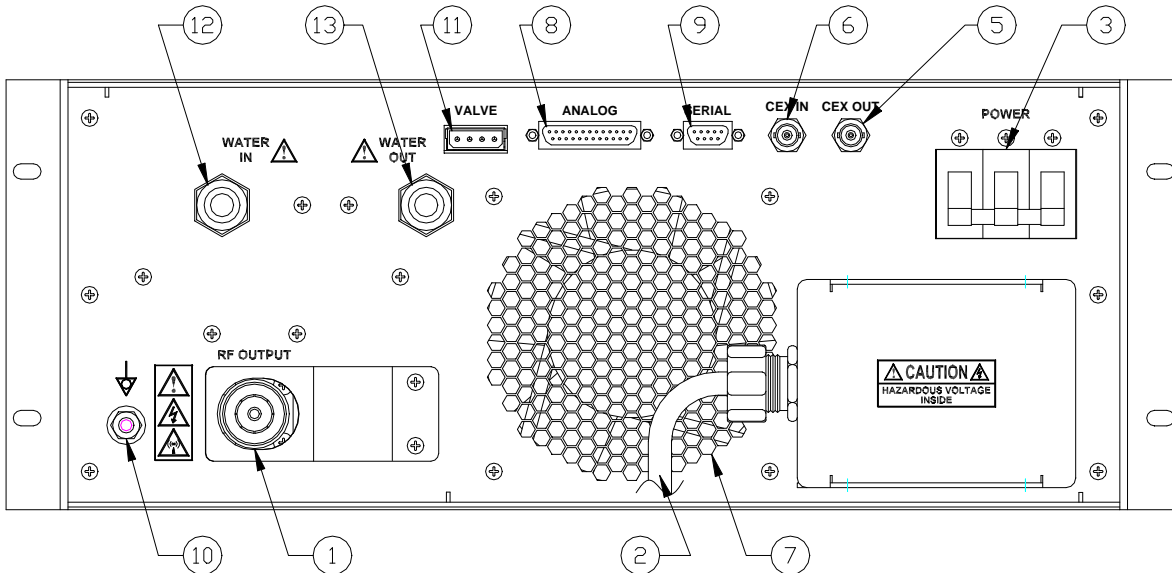

Models R5001, L5001 (5U Package)

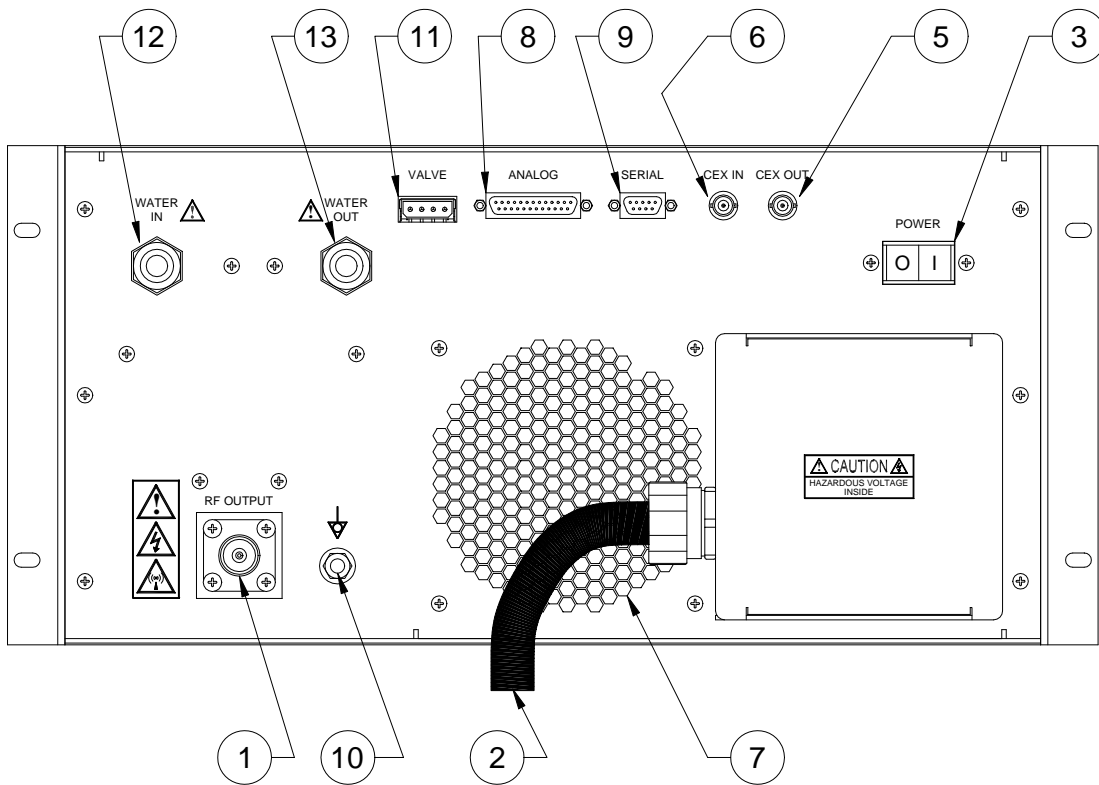

Model R10001

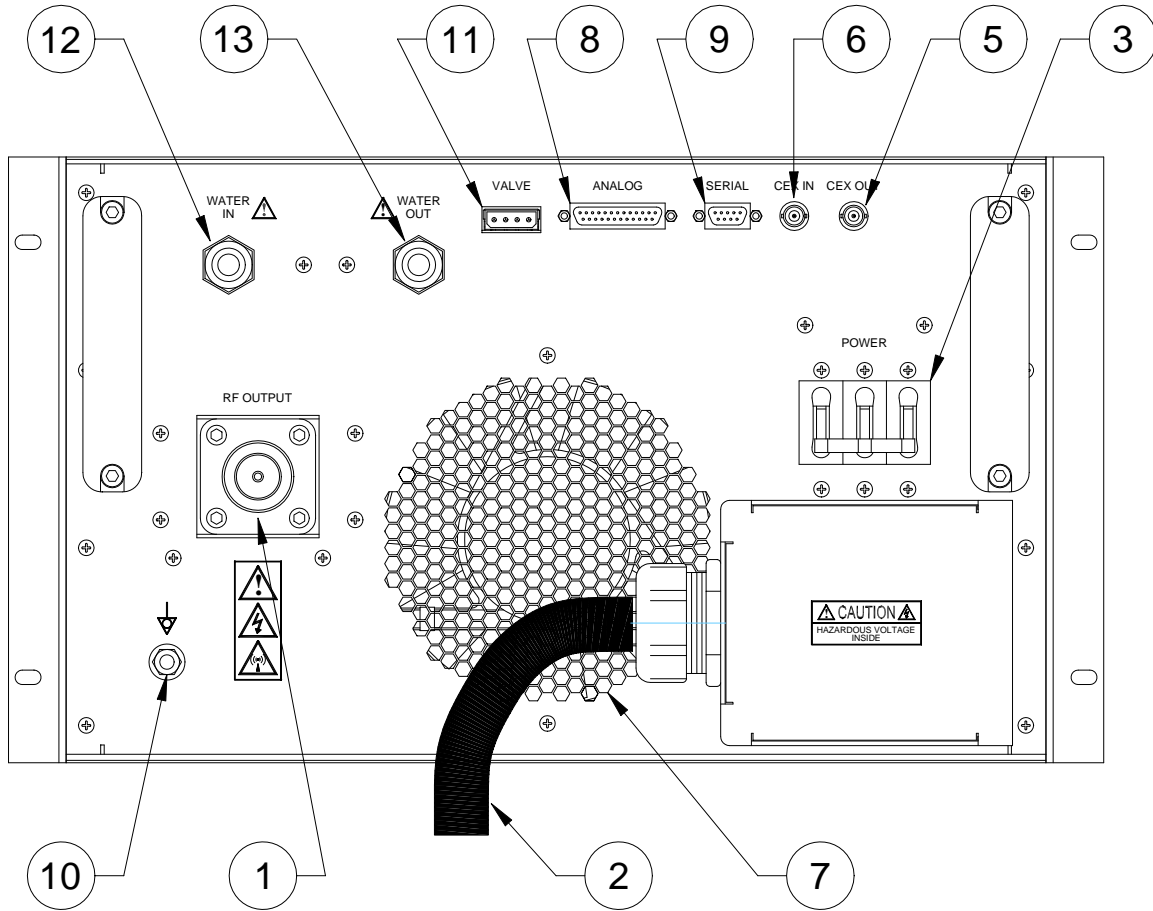

Model R15001

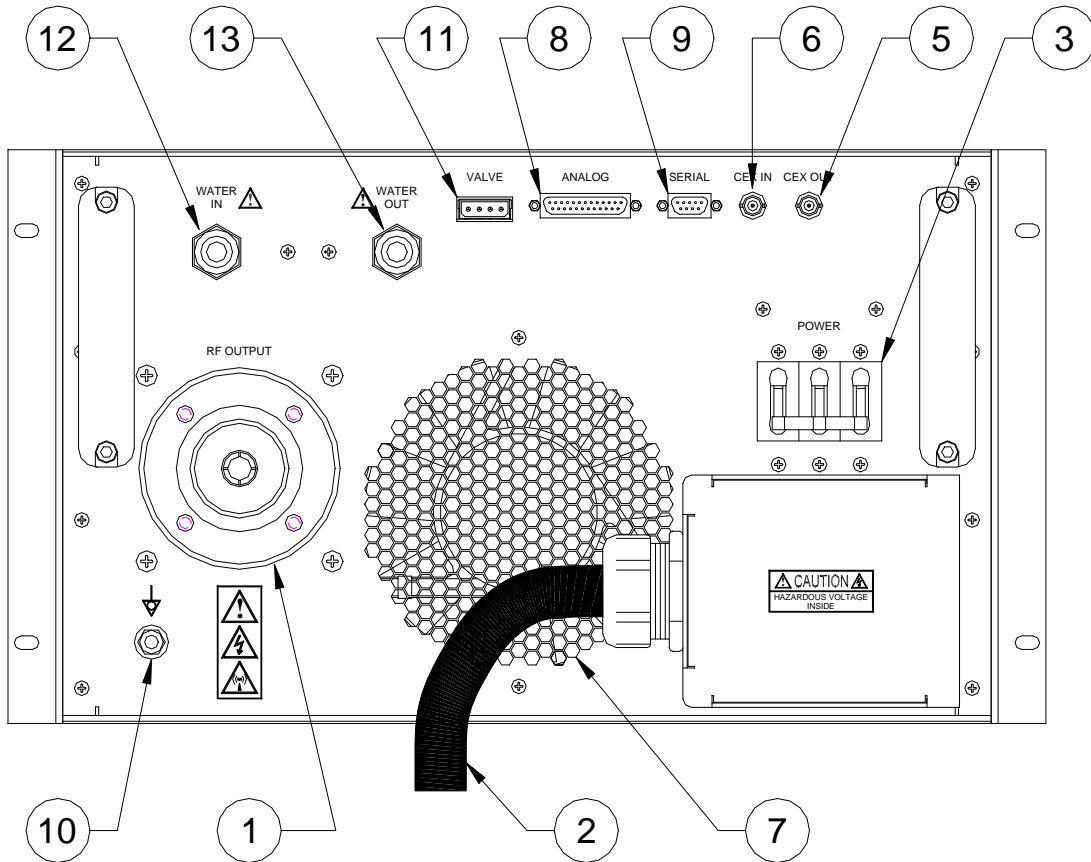

1. RF Output Connector

Connect a 50-Ohm coaxial cable from the RF Output connector to a 50-Ohm load (50-Ohm resistive load, impedance matching network, impedance matching transformer, plasma chamber, or other processing apparatus). The center pin of the connector is RF "hot", the connector shell is RF return.

2. Power Inlet or Captive Power Cord

Before connecting to AC Mains power, verify the AC Mains voltage marked on the ratings plate, located on the top or side panel of the RF Power Supply, is compatible with your AC Mains voltage. If the AC Mains voltage on the ratings plate is not compatible with your AC Mains voltage, contact a Seren IPS Inc. service depot for assistance.



CAUTION: CHECK YOUR MAINS VOLTAGE AND THE MAINS VOLTAGE SPECIFIED ON THE RATINGS PLATE OR CONSULT A QUALIFIED ELECTRICIAN BEFORE CONNECTING THE RF POWER SUPPLY TO MAINS POWER. CONNECTING TO THE WRONG MAINS VOLTAGE MAY DAMAGE THE RF POWER SUPPLY AND VOID THE WARRANTY.

Power Inlet: (Models with detachable power cords)

RF Power supply Models R/L101, R/L301, R/L101MKII, R/L301MKII, R/L601, R/L1001 are supplied with a rear panel power inlet and a detachable power cord. The cord type and Mains power plug are configured for the mains voltage specified at time of order.

Power Inlet Connector: IEC320 type male, filtered.

Mating Cord Connector: IEC320-C13.

Connect the supplied power cord to the power inlet and connect to mains power.



If the power cord is lost or damaged, replacement cords are available from Seren IPS Inc. or can be purchased locally. When purchasing a power cord from a local vendor, ensure the replacement cord is of the same wire gauge, current handling capacity, and voltage rating.

Captive Power Cord:

RF Power Supply Models R2001, L2001, R3001, L3001, R5001, and L5001 are supplied with captive power cords and locking power plugs. The power cord and power plug type are configured for the mains voltage specified at time of order.

RF Power Supply Models R8001, R10001, and R15001 are supplied with captive power cords, without power plugs. The installer is responsible for connecting/terminating the power cord in accordance with national and local codes.

3. Mains Circuit Breaker:

Set to the “1” position to enable, set to the “0” position to disable. To reset the circuit breaker, set the handle to the “0” position, then to the “1” position

4. DCP Connector (*Optional, Models R/L101,R/L301,R/L101MKII,R/L301MKII only*)

Voltage Probe Inverter Input. Analog input, 0 to –10VDC input range.

Connector: Type BNC Female

Input Impedance: 100K Ohm

Optional. Allows the RF Power Supply to use a negative polarity voltage probe signal from a passive probe (usually located in an external matching transformer or matching network) for external RF output regulation feedback (voltage control).

For RF Power Supplies with software version 9.0J2 and earlier:

Connect the negative polarity probe signal to the DCP connector. Connect Analog Interface connector pin 25 (INVPROBE output) to Analog Interface connector pin 24 (FEEDBACK input).

For RF Power Supplies with software version 9.0J3 and later:

Connect the negative polarity probe signal to the DCP connector and select inverted probe (**VLT CNTRL –PRB BNC**) from the programming menu

Note: Beginning with software version 9.0J3, a programming menu-controlled internal switch was added to route the probe inverter's output to the FEEDBACK signal. Refer to the Typical Interface Connections section for wiring details

5. CEX OUT Connector

Common Exciter output: 5 to 8V Peak-to-Peak, at specified operating frequency.

Connector: Type BNC Female

In “Master” mode, the common exciter output signal is present at all times regardless of the RF output state. In “slave” mode, the common exciter output signal is present when there is a signal present at the CEX IN connector.

In “Master” mode, the common exciter output frequency is the same as the programmed frequency. In “Slave” mode, the common exciter output frequency is the same as the signal at the CEX IN connector.

6. CEX IN Connector

Common Exciter input: 3 to 8V Peak-to-Peak sine wave, at specified operating frequency.

Connector: Type BNC Female

When in Slave mode, the RF Power Supply uses the common exciter input as its frequency source.



The CEX input signal must be the same frequency as the generator's specified output frequency. The RF Power supply will not produce output if the CEX input signal is out-of-band. An out-of-band CEX signal may cause internal damage to the RF power supply.

7. Fan Exhaust

Keep fan exhaust free of obstructions, dust and dirt.



When the RF Power Supply is mounted in an enclosure or equipment rack, ensure there is an adequate air intake and hot air exhaust. Operating the RF Power Supply at elevated temperatures or reduced airflow for long periods of time may degrade its reliability and/or void the warranty.

8. Analog Interface Connector

The analog interface connector is located on the rear panel of the Radio Frequency Power Supply. Control and status signals for the RF Power Supply are available on this connector. See the table below for descriptions of the interface connector signals.

Connector type: 25-pin female "D" sub-miniature.



To prevent radio frequency interference and ensure proper operation of the RF power Supply, foil-shielded cable is strongly recommended for making interface connections between the RF Power supply and system or accessory equipment.

Interface cables for accessory products are available from Seren IPS Inc., authorized Seren IPS representatives, and service depots. For assistance with system interfacing, contact your system vendor, Seren IPS Customer Service, or a Seren IPS service representative.



GND, GNDI, FWDRET, REFRET, FBRET, RFENABLED RET, and SETRET signals must be referenced at the user's system or the unit will not operate properly.

The RF Power Supply responds to input from the Analog Interface when ANALOG control has been selected. The External Interlock (pins 2 and 15) signal is active regardless of the selected control method.

Asterisk (*) denotes an active-low signal

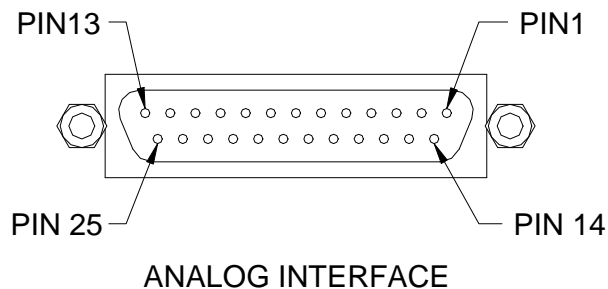

The RLX01 Series power supplies use a common Analog Interface connector, but some pin functions vary by model type. Where applicable, the variation in pin function has been noted.

ANALOG INTERFACE CONNECTOR PIN LIST		
PIN	SIGNAL NAME	DESCRIPTION
1	<p>MAINS INTLK 1 R101, L101, R301, L301 only</p>	<p>AC Mains Power Interlock. 24VAC current loop, 100 mA maximum current.</p> <p>A contact closure between pin 1 and pin 14 is required to allow AC mains power to engage. An open circuit between pin 1 and pin 14 disables AC mains power.</p> <p>This signal is active in Panel, Analog, or Serial control modes</p> <p>NOTE: Applicable to models R101, L101, R301, and L301 only.</p>
	<p>PSYNC R101MKII, L101MKII, R301MKII L301MKII, R/L601, R/L1001, R/L2001, R/L3001, R5001, R8001, R10001, R15001</p>	<p>Pulse Synchronization Output. TTL-compatible output, with an internal pull-up resistor.</p> <p>Outputs a pulse train from the internal pulse train generator when internal pulsing is selected and active.</p> <p>Outputs the pulse train from the Gate signal (pin 7) when external pulsing is selected.</p> <p>A TTL high state corresponds to RF output at SETPOINT level or "High Power Pulse" level, a TTL low state corresponds to 0 Watts or "Low Power Pulse" level. Refer to the pulsing parameters in the programmable parameters section for operational details.</p> <p>NOTE: Applicable to models R101MKII, L101MKII, R301MKII L301MKII, R/L601, R/L1001, R/L2001, R/L3001, R5001, R8001 R10001 and R15001.</p>
2	<p>INTERLOCK</p>	<p>External Interlock. TTL – compatible input, active low, with an internal pull-up resistor.</p> <p>A contact closure between pin 2 and pin 15 or a TTL "low" signal applied to pin 2 is required before RF output can be enabled.</p> <p>An open circuit or a TTL "high" signal applied to pin 2 while the RF output is enabled, will cause the RF output to turn off.</p> <p>An open circuit or a TTL "high" signal applied to pin 2 while the RF output is off, will prevent the RF output from being enabled.</p> <p>This signal is active in Panel, Analog, or Serial control modes</p>
3	<p>RFON*</p>	<p>RF Output Enable/Disable. TTL – compatible input, active low, edge triggered, with an internal pull-up resistor.</p> <p>A contact closure between pin 3 and pin 16 or a TTL signal transition from "high" to "low" applied to pin 3 enables the RF output, provided Pin 2 is at TTL "low" state.</p> <p>An open circuit between pin 3 and pin 16 or a TTL signal transition from "low" to "high" applied to pin 3 disables the RF output.</p> <p>This signal is active only in "Analog" control mode.</p>

ANALOG INTERFACE CONNECTOR PIN LIST		
PIN	SIGNAL NAME	DESCRIPTION
4	PWR/VLT*	<p>Power or Voltage leveling mode select. TTL – compatible input with internal pull-up resistor.</p> <p>An open circuit or TTL “high” signal applied to pin 4 selects the power supply’s internal power sensor for power regulation.</p> <p>A contact closure between pin 4 and pin 16 or a TTL “low” signal applied to pin 4 selects forward power regulation based on an external feedback signal (FEEDBACK signal - Pin 12).</p> <p>Refer to the controls section of the operator’s manual for detailed instructions on how to configure and use this mode.</p> <p>This signal is active only in “Analog” control mode.</p>
5	SLAVE*	<p>Selects internal oscillator/exciter or external oscillator/exciter (Slave Mode) as frequency source operation. TTL – compatible input with an internal pull-up resistor.</p> <p>A contact closure between pin 5 and pin 17 or applying a TTL “low” signal to pin 5 selects external frequency source (Slave Mode) operation. The external frequency source is connected to the “CEX IN” connector on the rear panel.</p> <p>An open circuit or TTL “high” applied to pin 5 selects the power supply’s internal oscillator/exciter as the frequency source.</p> <p>This signal is active only in “Analog” control mode.</p>
6	GATEN*	<p>Selects Continuous Wave (CW) or Pulse Operation. TTL – compatible input with an internal pull-up resistor.</p> <p>A contact closure between pin 6 and pin 17 or applying a TTL “low” signal to pin 6 selects pulse operation. Apply the external pulse train to Pin 7.</p> <p>Applying a logic level high to this pin or allowing this pin to float selects continuous wave (CW) operation.</p>
7	GATE	<p>External Pulse Train input. Toggles output power between setpoint value and 0 Watts. TTL - compatible input with internal pull-up resistor.</p> <p>An open circuit or TTL “high” signal applied to pin 7 holds the RF output to the setpoint level.</p> <p>A contact closure between pin 7 and pin 17 or a TTL ‘low’ signal applied to pin 7 switches the RF output power to 0 Watts.</p> <p>Active when pin 6 (GATEN*) is in a TTL “low” state.</p>
8	RFENABLED*	<p>RF output status signal. Active low, open collector output. 24VDC, 15mA maximum current sink, 150mW maximum power dissipation.</p> <p>Signal output is 0V (low) for an RF on condition; signal output is “open” for an RF off condition.</p> <p>The RFENABLED* signal can also indicate the presence of</p>

ANALOG INTERFACE CONNECTOR PIN LIST		
PIN	SIGNAL NAME	DESCRIPTION
		<p>excessive reflected power by changing from a “low” state to a “high” state when the RF output is enabled. Refer to “Reflected Power Alarm ON/OFF” and “Reflected Alarm Threshold” in the Programmable Parameters section for details.</p> <p>The RFENABLED* output signal may also be used to pre-position Seren IPS Inc. AT-Series Matching Networks. Refer to “Matching Network Preset Mode”, “Tune Capacitor Preset Position”, and “Load Capacitor Preset Position” in the Programmable Parameters section. Requires +5VDC pull-up enabled.</p> <p>NOTE: For units manufactured on or before July 30, 2005, this pin is internally pulled up to +5VDC. For unit manufactured on August 1, 2005 and later, this pin may be configured as internally pulled up to +5VDC (factory default configuration) or without a +5VDC pull-up. (OEM custom configurations). Configuration is set at the factory. Use pin 18 for a reference return.</p>
9	GND	Internally connected to chassis ground. Connect to system controller common or ground reference.
10	FWD MON	<p>Forward power monitor output signal. Analog output, selectable 0 to +5VDC or 0 to +10VDC range via front panel controls.</p> <p>Output is linearly proportional to 0 to 100% of rated forward power.</p> <p>Refer to the Power Monitor Scaling subsection in the appropriate model specification for forward power monitor scaling details.</p> <p>The forward power monitor output signal may also be used to pre-position Seren IPS Inc. AT-Series Matching Networks. Refer to “Matching Network Preset Mode”, “Tune Capacitor Preset Position”, and “Load Capacitor Preset Position” in the Programmable Parameters section.</p> <p>Measure monitor voltage with respect to pin 22 (FWDRET).</p>
11	REFP MON	<p>Reflected power monitor output signal. Analog output, selectable 0 to +5VDC or 0 to +10VDC range via front panel controls.</p> <p>Refer to the Power Monitor Scaling subsection in the appropriate model specification for reflected power monitor scaling details.</p> <p>The reflected power monitor output signal may also be used to pre-position Seren IPS Inc. AT-Series Matching Networks. Refer to “Matching Network Preset Mode”, “Tune Capacitor Preset Position”, and “Load Capacitor Preset Position” in the Programmable Parameters section.</p> <p>Measure monitor voltage with respect to pin 23 (REFRET).</p>

ANALOG INTERFACE CONNECTOR PIN LIST		
PIN	SIGNAL NAME	DESCRIPTION
12	FEEDBACK	<p>External feedback voltage signal. Analog input, 0 to +10.0VDC . Use pin 16 or 17 or (GNDI) for return reference.</p> <p>The RF Power Supply will automatically adjust its output power to maintain the FEEDBACK signal's magnitude at the same level as the SETPOINT signal magnitude. The PROBE voltage will be displayed on the front panel. The PROBE attenuation factor can be configured from the front panel.</p> <p>The external feedback signal is derived from a voltage probe (RF or DC) located elsewhere in the plasma or process system. Refer to the controls section for detailed instructions on how to configure and use this mode.</p> <p>Note: The feedback voltage polarity must match the setpoint input's (pin 13) polarity for proper operation of voltage control mode. The RF Power Supply's external feedback circuitry is not designed to function with Negative (-) polarity signals applied to this pin.</p>
13	SETPOINT	<p>Power or Voltage setpoint input. Analog, high-impedance, differential input with selectable 0 to +5.0VDC or 0 to +10.0VDC range via front panel controls.</p> <p>Refer to the controls section of the operator's manual for detailed instructions on how to configure and use this mode</p> <p>NOTE: SETRET (pin 25) MUST be referenced to common or ground at the setpoint voltage source (system controller) or the RF output power will behave erratically.</p> <p>Refer to the Analog Setpoint Sensitivity subsection of the appropriate model specification for setpoint sensitivity details.</p> <p>NOTE: Feedback voltage range and polarity must match setpoint voltage range and polarity for proper operation in voltage control mode.</p> <p>Pin 13 is the positive (+) input of the differential setpoint amplifier.</p> <p>Active only in ANALOG control mode.</p>
14	MAINS INTLK 2 R101, L101, R301, L301 only	<p>A contact closure between pin 1 and pin 14 is required to allow AC mains power to engage. An open circuit between pin 1 and pin 14 disables AC mains power. 24VAC current loop, 100 mA maximum current</p> <p>This signal is active in Panel, Analog, or Serial control modes</p> <p>NOTE: Applicable to models R101, L101, R301, L301 only.</p>
	No Connection R101MKII, L101MKII, R301MKII	<p>No Connection</p> <p>Note: Applicable to models R101MKII, L101MKII, R301MKII,</p>

ANALOG INTERFACE CONNECTOR PIN LIST		
PIN	SIGNAL NAME	DESCRIPTION
	L301MKII, R/L601, R/L1001, R/L2001, R/L3001, R5001, R8001, R10001, R15001	L301MKII, R/L601, R/L1001, R/L2001, R/L3001, R5001, R8001, R10001, and R15001
15	INTERLOCK-RTN	Ground return for External Interlock (pin 2)
16	GNDI	Ground return for pins 3,4,5,6,7,19. Internally connected to chassis ground. Connect to system controller common or ground reference
17	GNDI	Ground return for pins 3,4,5,6,7,19. Internally connected to chassis ground. Connect to system controller common or ground reference
18	RFENABLED RET	Ground return for pin 8 (RFENABLED* signal). For units manufactured on or before July 30, 2005, this pin is internally connected to chassis ground (GNDI). For unit manufactured on August 1, 2005 and later, this pin may be configured as internally connected to chassis ground (GNDI) (factory default configuration) or isolated from chassis ground (OEM custom configurations). Configuration is set at the factory. Connect to system controller common or ground reference.
19	RL-IN	Remote Limit input. Analog input, 0 to +5VDC range. Use pin 16 or 17 (GNDI) for return reference. Used in dual-bias or multiple power supply systems to fold-back the power supply's output power if reflected power is detected by another power supply in the system. Output power folds back in response to an external voltage applied to this input. Foldback threshold is factory preset at +5.00VDC (Disabled). Consult factory for assistance.
20	RL-OUT	Remote Limit Output. Analog output, 0 to +10VDC range. Buffered, high-speed, non-linearized directional coupler reflected power signal. Return reference is pin 23. Used on dual-bias or multiple power supply systems. Consult factory for assistance.
21	PHASE	External Phase Sensor Input. Analog Input, -10.0VDC to +10.0VDC range. Used in conjunction with the Variable Frequency Tuning (VFT) feature. On VFT-enabled units with VFT Feedback Mode set to "PHASE TUNE MODE +" or "PHASE TUNE MODE -" the

ANALOG INTERFACE CONNECTOR PIN LIST		
PIN	SIGNAL NAME	DESCRIPTION
		<p>voltage signal from an external phase detector is used to steer the RF output's frequency.</p> <p>The external phase detector's output is applied to the PHASE input signal. When the PHASE signal is 0.00VDC, the RF Power Supply assumes reflected power is at minimum and stops the tuning process.</p>
22	FWDRET	Forward Power Monitor return. Analog output. For pin 10.
23	REFRET	Return reference for Reflected Power Monitor and Remote Limit output signals. Analog output. For pins 11 and 20.
24	No Connection	<p>No Connection</p> <p>NOTE: Applicable to: Models R101MKII, L101MKII, R301MKII L301MKII with software version 9.0J3 or greater, <i>with or without</i> rear panel "DCP" connector installed. Models R101, L101, R301, L301 <i>without</i> rear panel "DCP" connector installed. Models R/L601, R/L1001, R/L2001, R/L3001, R5001, R8001, R10001, and R15001</p>
	<p>FEEDBACK R101, L101 R301, L301 R101MKII, L101MKII, R301MKII L301MKII Models only</p>	<p>Note: This pin function is not supported on units with software version 9.0J3 or greater because the user can route the inverted probe signal to pin 12 via a selection in the programming menu.</p> <p>External feedback voltage signal. Analog input, 0 to +10.0VDC. Internally connected to pin 12. Use pin 16 or 17 (GNDI) for return reference.</p> <p>The RF Power Supply will automatically adjust its output power to maintain the FEEDBACK signal's magnitude at the same level as the SETPOINT signal magnitude. The PROBE voltage will be displayed on the front panel. The PROBE attenuation factor can be configured from the front panel.</p> <p>The external feedback signal is derived from a voltage probe (RF or DC) located elsewhere in the plasma or process system. Refer to the controls section for detailed instructions on how to configure and use this mode.</p> <p>Note: The feedback voltage polarity must match the setpoint input's (pin 13) polarity for proper operation of voltage control mode.</p> <p>Note: Applicable <i>only</i> to models R101, L101, R301, L301, R301MKII, L301MKII with software version 9.0J2 or less, with optional "DCP" connector installed on the rear panel.</p>

ANALOG INTERFACE CONNECTOR PIN LIST		
PIN	SIGNAL NAME	DESCRIPTION
25	SETRET	<p>Setpoint Return. Analog differential input (-). Note: This pin <i>must</i> be connected to a ground reference or the unit's output will behave erratically</p> <p>NOTE: Applicable to: Models R101MKII, L101MKII, R301MKII, and L301MKII with software version 9.0J3 or greater, <i>with or without</i> rear panel "DCP" connector installed. Models R101, L101, R301, L301 <i>without</i> rear panel "DCP" connector installed. Models R/L601, R/L1001, R/L2001, R/L3001, R5001, R8001, R10001, R15001</p>
	INVPROBE R101, L101 R301, L301 R101MKII, L101MKII, R301MKII L301MKII Models only	<p>Note: This pin function is not supported on units with software version 9.0J3 or greater because the user can route the inverted probe signal to pin 12 via a selection in the programming menu.</p> <p>Inverted Probe Output. Analog output, 0 to +10.0VDC. Inverted polarity signal derived from the optional rear panel "DCP" BNC connector. Magnitude of the signal remains identical, polarity changed from negative (at the PROBE connector) to positive. Connect to pin 24 (if required) when using external feedback to regulate RF output level.</p> <p>Note: Applicable <i>only</i> to models R101, L101, R301, L301, R301MKII, L301MKII with software version 9.0J2 or less, with optional "DCP" connector installed on the rear panel.</p>

TYPICAL INTERFACE CIRCUITS

Figures 1 through 5 illustrate the typical circuits used in the RF Power Supply's Analog Interface.

Note: GND, GNDI, and SETRET signals must be referenced to system common or system ground to avoid erratic power supply operation.

RFENABLED* Output Circuit:

RF output status signal. Signal output is closed (0V or "low") for an RF ON condition; signal output is "open" for an RF OFF condition or Reflected Power Alarm condition. The reflected power alarm indication can be disabled. Refer to the Programming Menu "Reflected Alarm ON/OFF" and "Reflected Alarm Threshold" parameters and the Analog Interface Pin List table for operational details.

Default Configuration: Active low, open collector output with +5VDC pull-up. (No pull-up and isolated configurations are possible, consult factory for details)

Signal Rating: 24VDC maximum (with pull-up disabled), 15mA maximum current sink, 150mW maximum power dissipation.

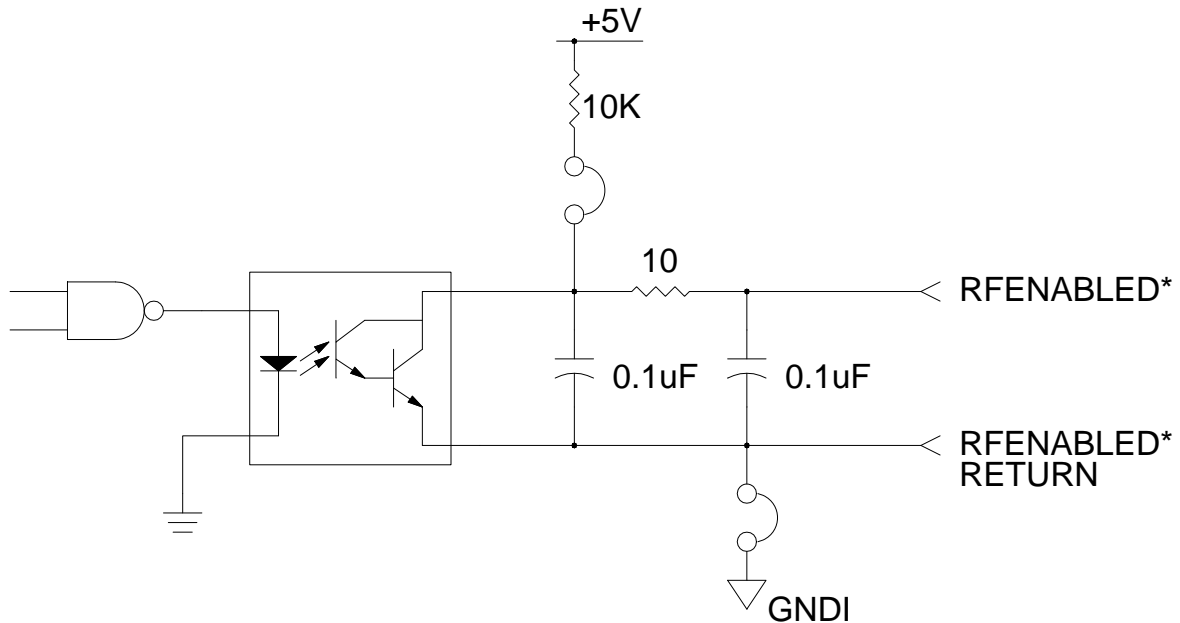

Figure 1: RFENABLED* Circuit

TTL-Compatible Input Circuits

All TTL-Compatible logic input circuits are internally pulled up to +5VDC. Signal function and response is as described in the Analog Interface Connector pin list.

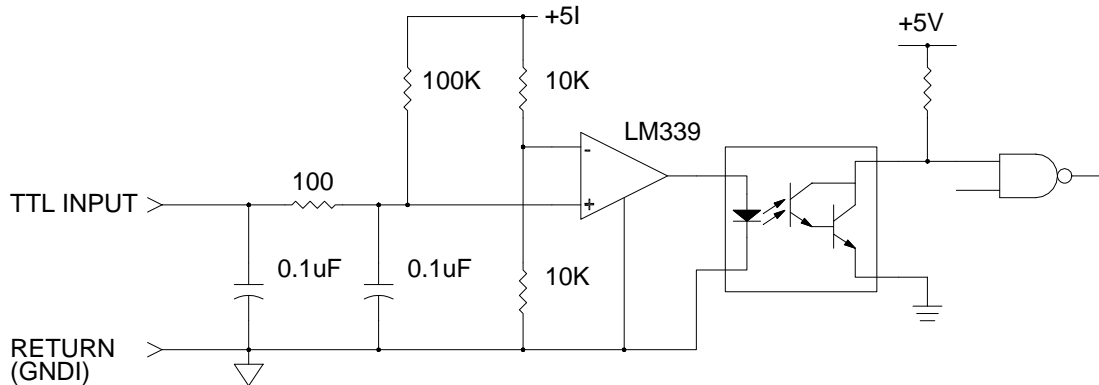

Figure 2: TTL-Compatible Input Circuits

SETPOINT Input Circuit

High-impedance, high Common-Mode Rejection Ratio, differential analog input. Input voltage range is software selectable 0 to +5.0VDC or 0 to +10.0VDC via the front panel controls. NOTE: The setpoint return signal (SETRET, pin 25) **MUST** be referenced to common or ground at the setpoint voltage source (system controller) or the RF output power will behave erratically.

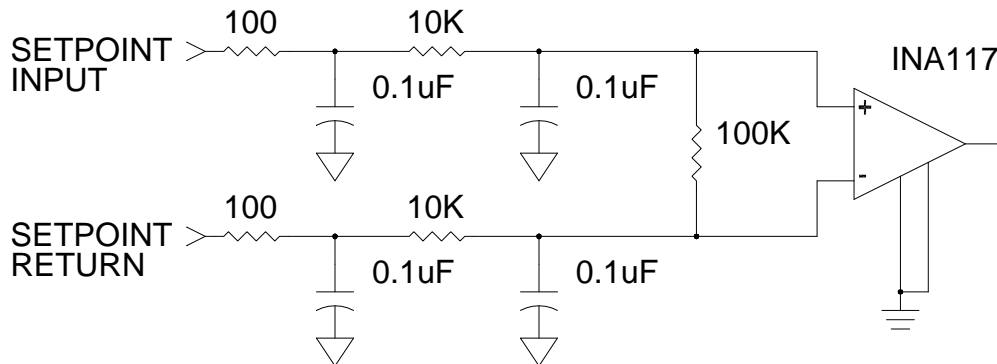

Figure 3: SETPOINT Input Circuit

FEEDBACK Input Circuit

High-impedance, high Common-Mode Rejection Ratio, analog input. Input voltage range is 0 to +10.0VDC. NOTE: The feedback return signal (GNDI, pin 16 or 17) ***MUST*** be referenced to common or ground at the feedback voltage source (Voltage Probe) or the RF output power will behave erratically.

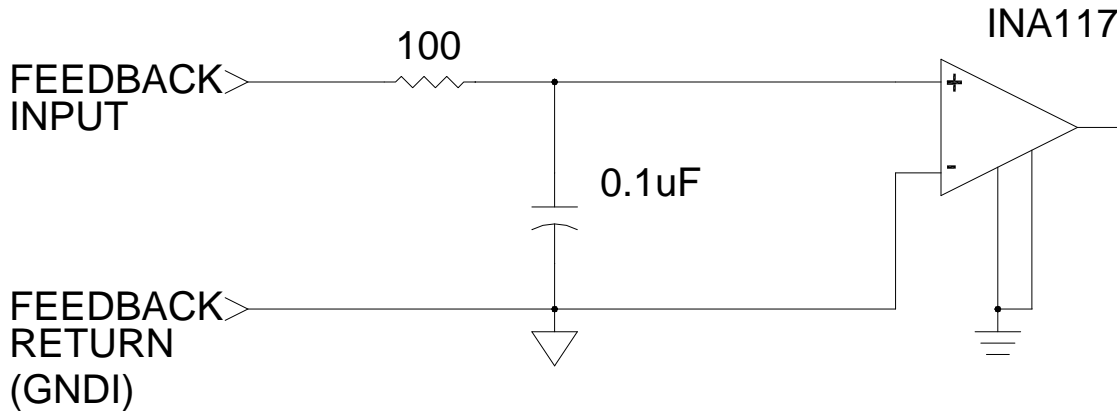

Figure 4: FEEDBACK Input Circuit

MONITOR Output Circuit

Analog output, selectable 0 to +5VDC or 0 to +10VDC range via front panel controls. Normal function is forward or reflected power monitoring, but can be configured to pre-position Seren IPS Inc. AT-Series Matching Networks. See the Programming Menu reference for additional details.

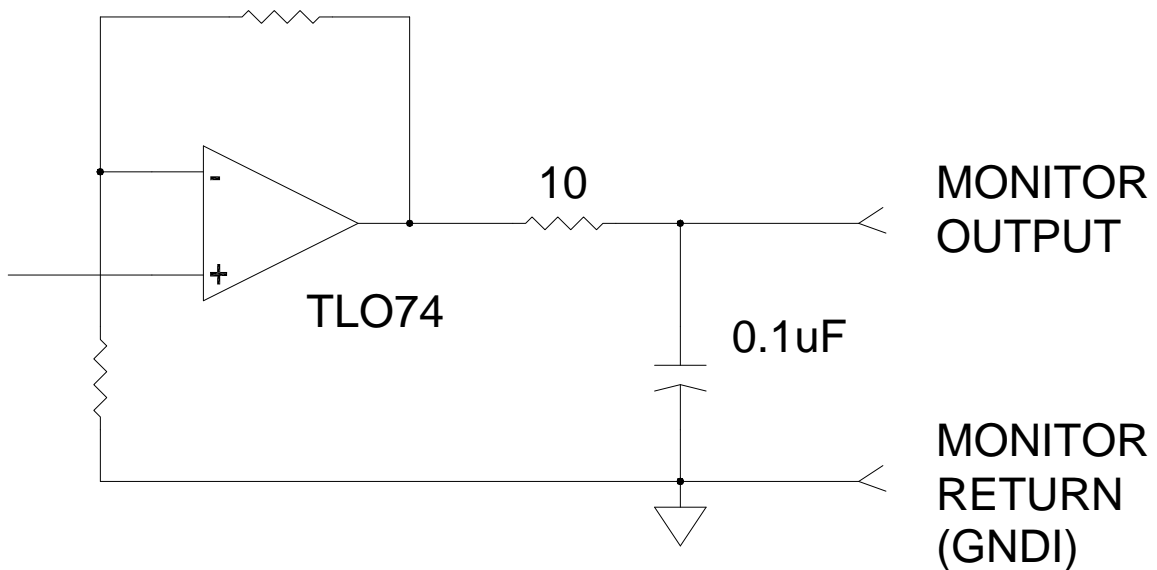
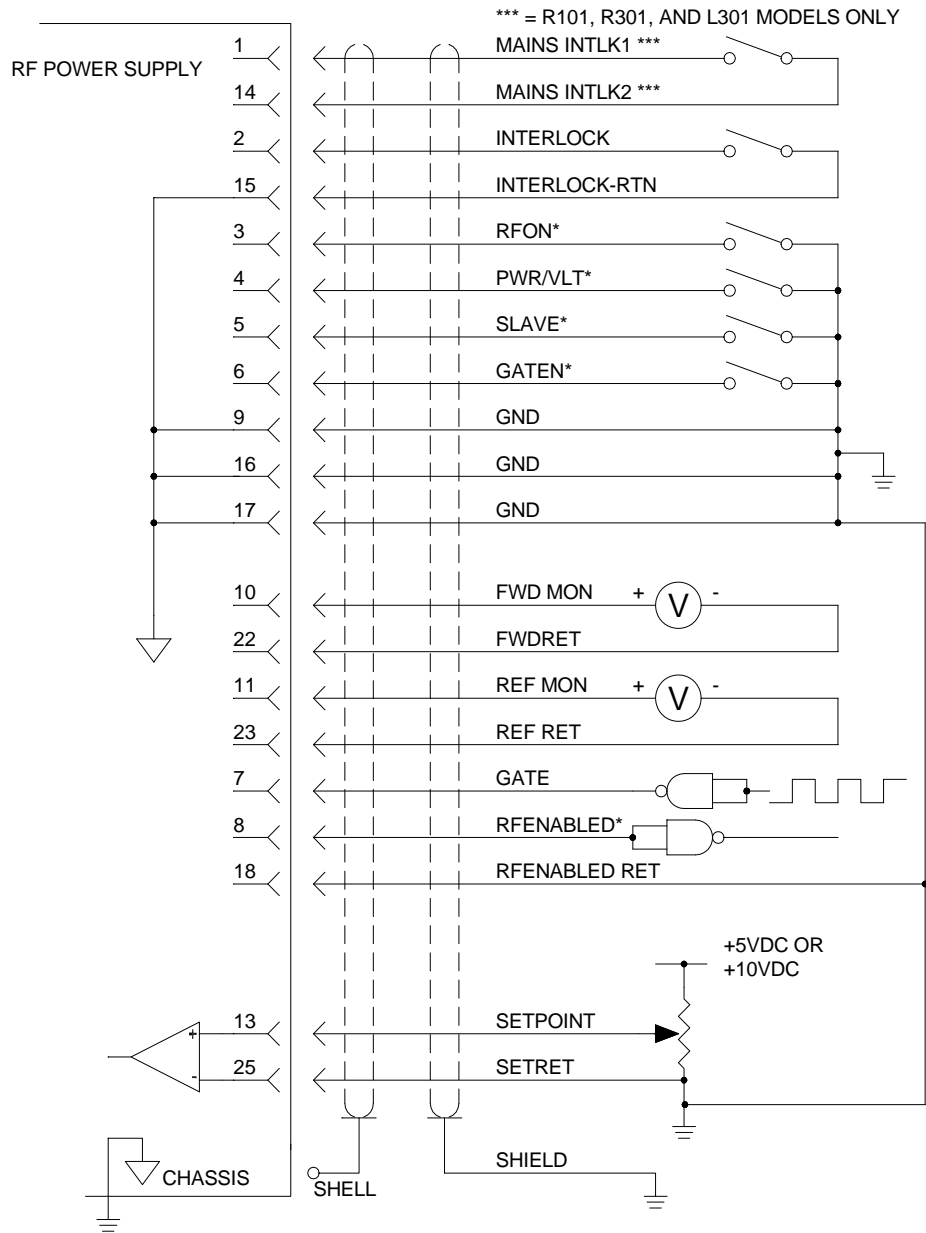

Figure 5: MONITOR Output Circuit

TYPICAL ANALOG INTERFACE CONNECTIONS

Analog Control

There are many possible analog interface wiring schemes. Basic analog interface connections are diagrammed below. Refer to the Analog Interface Connector pin list in the Rear Panel Controls and Connections section for signal details. Use shielded cable for all interconnections.



Typical Analog Interface Connections

External Feedback with Probe Inverter Option

The RF power supply's external feedback input (FEEDBACK, analog interface connector pin 12) only accepts a positive (+) polarity signal. The Probe Inverter feature allows the R101, R101MKII, L101MKII, R301, R301MKII, L301, and L301MKII RF Power Supplies to utilize a negative polarity feedback signal.

For units with software version 9.0J2 or earlier, Connect the negative polarity external feedback signal to the rear panel "DCP" BNC connector and connect Analog Interface connector pin 24 to pin 25.

For units with software version 9.0J3 or later, Connect the negative polarity external feedback signal to the rear panel "DCP" BNC connector and select inverted probe from the programming menu (VLT CNTRL -PRB BNC)

Note: Beginning with software version 9.0J3, a programming menu-controlled internal switch was added to route the probe inverter's output to the FEEDBACK signal.

If desired, the inverted probe signal may also be routed to the user's system for monitoring purposes. Use analog interface connector pins 12 (FEEDBACK) and 16 (GNDI). Connections **must** be made with shielded cable to prevent interference to the feedback signal.

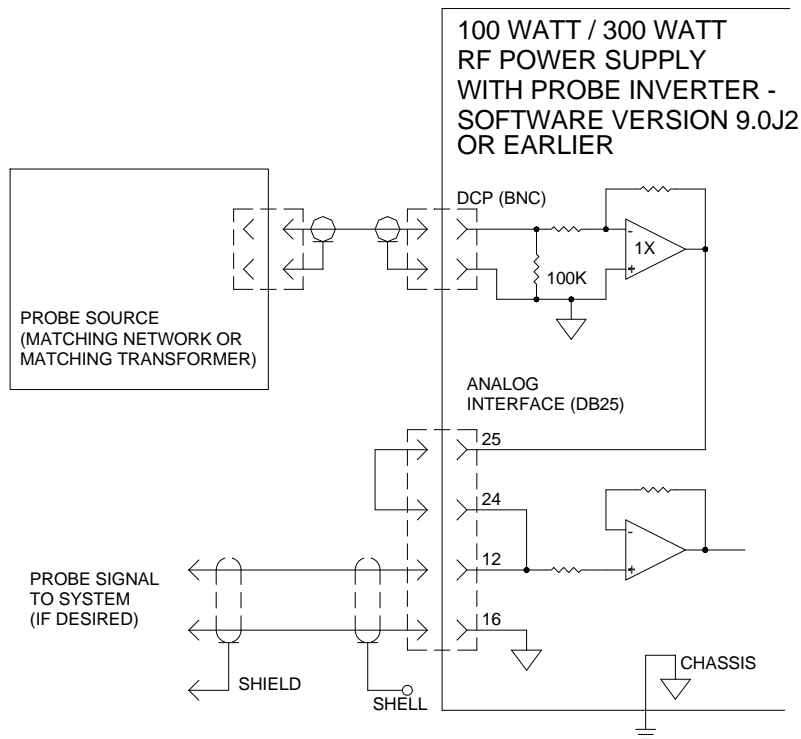

Probe Inverter Connections
Software version 9.0J2 and Earlier

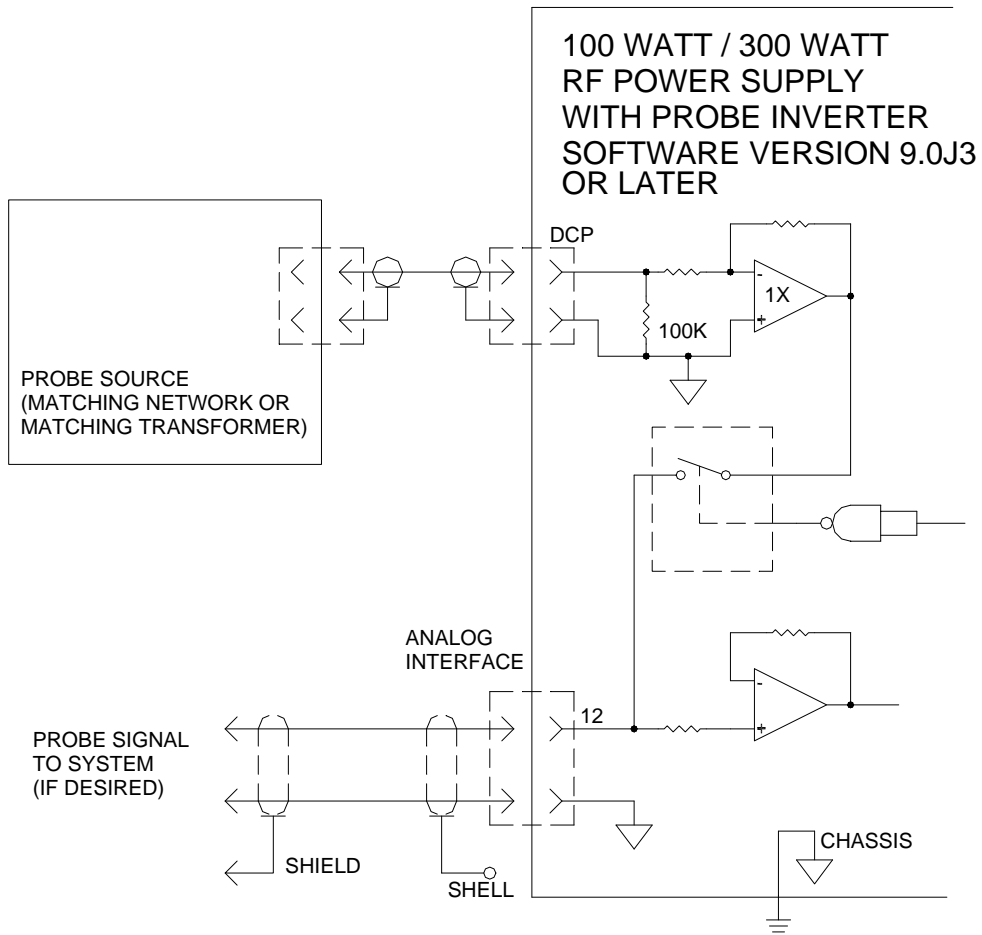

Probe Inverter Connections
Software version 9.0J3 and Later

9. Serial Interface Connector

The serial interface provides remote control and monitoring of the RF Power Supply via a computer. Serial interface protocols are selectable, RS-232, RS-422, and RS-485. Baud rates and protocols are selected via the front panel.

Connector Type: 9 pin "D" female

For serial operation details, see the Serial Commands section of this manual.

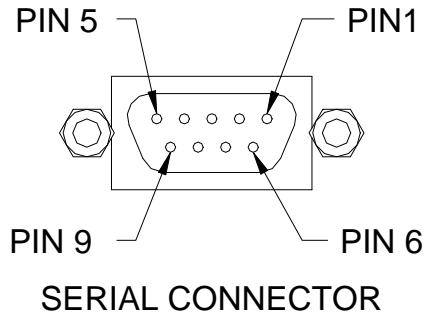

Note: To accommodate multi-protocol operation, Seren RF Power Supplies use a non-standard serial interface connector pin assignment.

SERIAL INTERFACE CONNECTOR PIN LIST		
Pin	Signal	Description
1	No Connection	No Connection
2	TXB-232	RS-232 Transmit Data (Internally connected to pin 4)
3	RXB-232	RS-232 Receive Data
4	TXB-232	RS-232 Transmit Data (Internally connected to pin 2)
5	+RCV	RS-422/485-4 +RCV
6	-RCV	RS-422/485-4 -RCV
7	+XMIT	RS-422/485-4 +XMIT (RS-485-2 RCV/XMIT)
8	-XMIT	RS-422/485-4 -XMIT (RS-485-2 RCV/XMIT)
9	Common	Common

Serial Interface Wiring: RS-232

Seren IPS strongly recommends the use of shielded cable when making serial interface connections. The use of unshielded cable may result in data errors and other serial communication problems.

Typical RS-232 serial interface wiring is diagrammed below. .

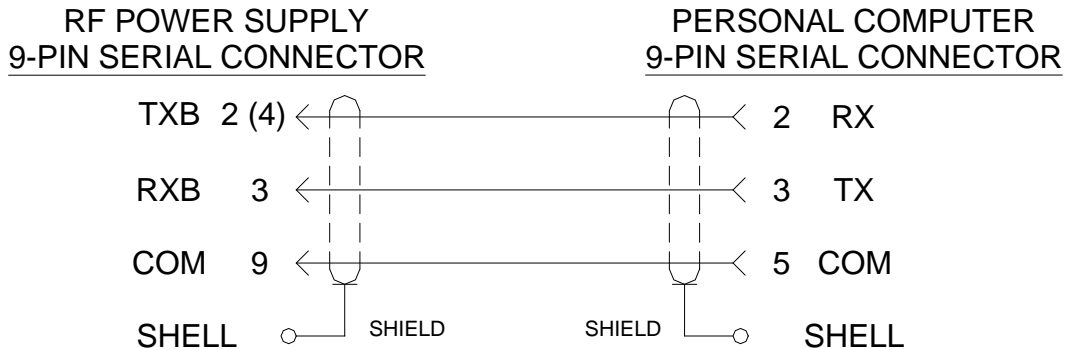

RS-232 Serial Interface Wiring

Seren RF Power Supply to Personal Computer 9-pin Serial Connector

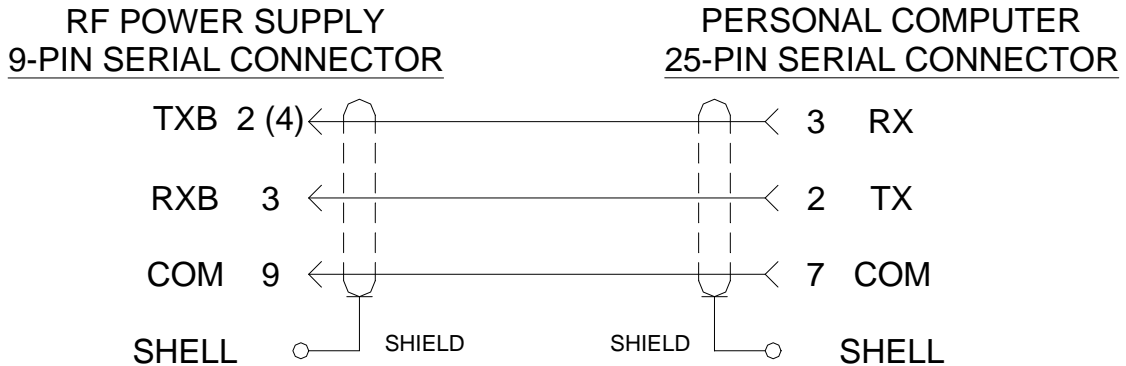

RS-232 Serial Interface Wiring

Seren RF Power Supply to Personal Computer 25-pin Serial Connector

Serial Interface Wiring: 4-Wire RS-485 and RS-422

Typical wiring for 4-Wire RS-485 and RS-422 serial interface connections are shown below. Not all hardware manufacturers implement the industry-recommended connector pin-outs for RS-485/RS-422 communications, so it is strongly advised that you consult the documentation provided with your RS-485 or RS-422 serial interface hardware, the Serial Interface Connector Pin List of the Seren product(s), and the serial interface pin list(s) of other devices to determine the proper wiring method for your hardware.

Seren IPS strongly recommends the use of low-capacitance shielded cable when making serial interface connections. The use of unshielded cable may result in data errors and other serial communication problems.

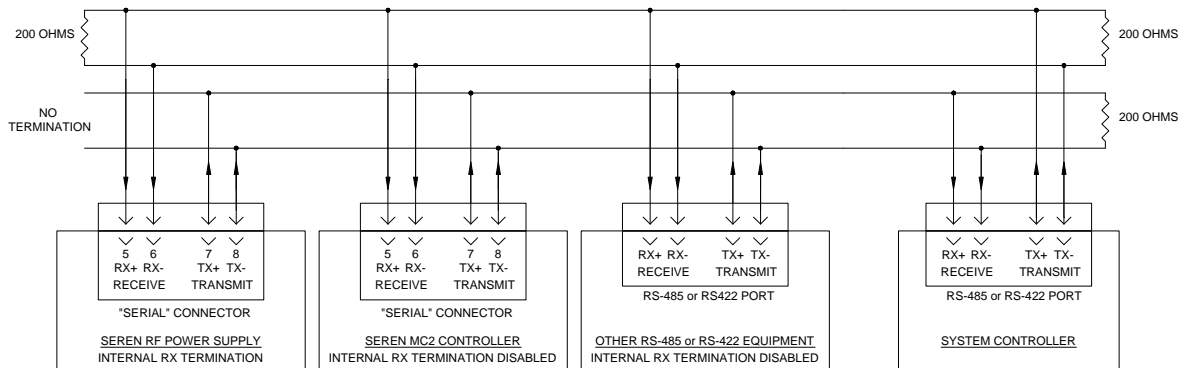

Typical 4-Wire RS-485 / RS-422 Connections

Protocols:

All devices on the serial bus must be configured for the same protocol, RS-485 or RS-422. Do not mix protocols on the serial bus.

Termination:

Seren IPS RF Power Supplies have an internal 200 Ohm termination connected across pins 7 and 8 of the Serial Interface connector. This termination is permanently enabled and is not configurable.

Seren IPS MC2 Matching Network Controllers have an internal 200 Ohm termination connected across pins 7 and 8 of the Serial interface connector (default configuration). The MC2 controller's internal 200 Ohm termination can be disabled by removing shunt jumpers JP1 and JP2 on the MC2's main PCB - consult Seren IPS technical support for detailed information.

If the system's RS-485 or RS-422 interface does not have built-in termination, the 200 Ohm termination resistors shown in the connection diagram above must be connected.

Serial Interface Wiring: 2-Wire RS-485

Typical wiring for 2-Wire RS-485 serial interface connections are shown below. Not all hardware manufacturers implement the industry-recommended connector pin-outs for RS-485 communications, so it is strongly advised that you consult the documentation provided with your RS-485 serial interface hardware, the Serial Interface Connector Pin List of the Seren product(s), and the serial interface pin list(s) of other devices to determine the proper wiring method for your hardware.

Seren IPS strongly recommends the use of low-capacitance shielded cable when making serial interface connections. The use of unshielded cable may result in data errors and other serial communication problems.

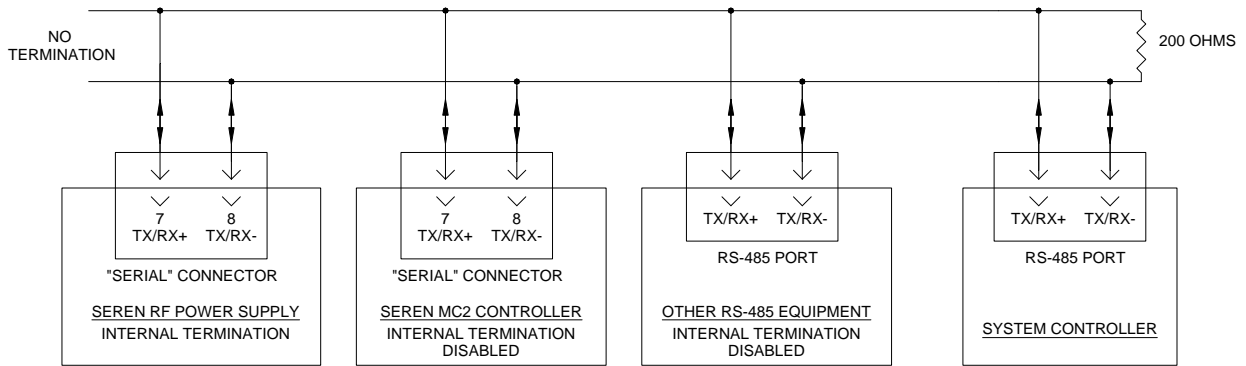

Typical 2-Wire RS-485 Connections

Protocols:

All devices on the serial bus must be configured for RS-485 protocol. *Do not mix protocols* on the serial bus.

Termination:

Seren IPS RF Power Supplies have an internal 200 Ohm termination connected across pins 7 and 8 of the Serial Interface connector. This termination is permanently enabled and is not configurable.

Seren IPS MC2 Matching Network Controllers have an internal 200 Ohm termination connected across pins 7 and 8 of the Serial interface connector (default configuration). The MC2 controller's internal 200 Ohm termination can be disabled by removing shunt jumpers JP1 and JP2 on the MC2's main PCB - consult Seren IPS technical support for detailed information.

If the system's RS-485 interface *does not* have built-in termination, the 200 Ohm termination resistor shown in the connection diagram above must be connected.

Serial Interface Wiring: Serial Pass-Through to Seren IPS MC2 Controller

A feature of Seren IPS Inc. R/LX01-Series RF Power Supplies is the ability to send RS-232 serial commands to a Seren IPS model MC2 Matching Network Controller via the RF Power Supply, so that only one RS-232 connection is needed to control both units.

To accomplish this, the RF Power Supply's RS-232 port is connected to the system controller (computer, process controller, etc.) and the RF Power Supply's RS-485 port is connected to the MC2's RS-485 port. The RF Power Supply supports a set of "MC2 Pass-Thru" commands; the RF Power Supply acts as a relay between the system controller and the MC2.

Operational Notes:

1. When using this feature, the RF Power Supply only supports RS-232 serial communication to the system controller because the RF Power Supply's RS-485 port is used to communicate with the MC2 matching network controller.
2. The RF Power Supply does not use or store the commands and data sent to and from the MC2 matching network controller.

Example:

To determine the position of the matching network's Tune capacitor, the system controller would send the "TPS" command to the RF Power Supply. The RF Power Supply would then send the "TPS" command to the MC2, the MC2 would send the Tune capacitor position back to the RF Power Supply. The RF Power Supply would then report the Tune capacitor position to the system controller.

The "MC2 Pass-Thru" serial commands are:

ALD, ATN, GOTO, LPS, TPS, MLD, MPL, MPT, MTN, PHS, and MAG.

The "MC2 Pass-Thru" commands are listed in the **Serial Command Reference Chart** and are discussed in-depth in the **Serial Communications: Serial Command Details, RS232, RS422, and RS485** section of this document.

MC2 "Pass-Thru" Connections:

Seren IPS Inc. offers accessory cables for this application that can be purchased separately: Serial Breakout Cable P/N 9100140000 and RS422/485 Serial I/O Cable P/N 910012XXXX , where "xxxx" indicates the desired cable length in inches. Please contact the factory or an authorized Seren IPS representative for details. A cable can also be constructed based on the following wiring diagram:

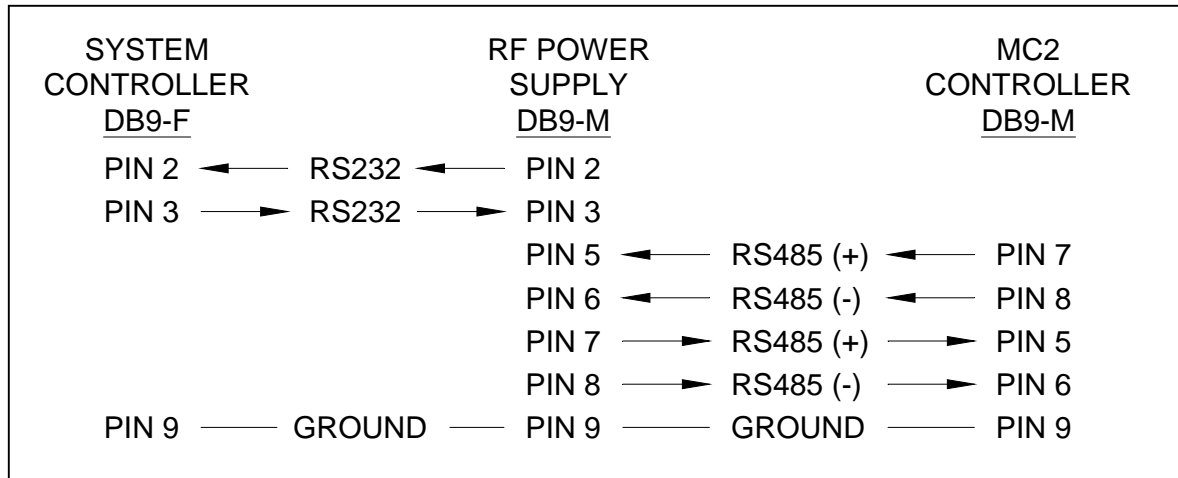

"Pass-Thru" Serial Interface Wiring Diagram

The diagram above was created assuming that the RS-232 port on the system controller is a 9-pin male D-subminiature connector using the standard PC pin-out. The diagram shows the connector types needed on the cable to mate with the connectors on the equipment.

Seren IPS strongly recommends the use of low-capacitance shielded cable when making serial interface connections. The use of unshielded cable may result in data errors and other serial communication problems. For clarity, the shield is not shown in the diagram above. Connect the shield drain wires to the D-subminiature connector housings at each piece of equipment.

MC2 "Pass-Thru" Setup:

1. Choose a common baud rate for all equipment.
2. Set the system controller to the common baud rate, Data Bits = 8, Stop Bits = 1, Parity = NONE, Flow Control = NONE.
3. Set the RF Power Supply for RS232 control at the common baud rate.
4. Set the MC2 Matching Network Controller for RS485-4, Address = 0 (zero), common baud rate.
5. Set the MC2 Matching Network Controller to ECHO: DISABLED (IMPORTANT: press the ENT softkey even if the setting is already correct).
6. Configure the equipment as shown in the diagram below.

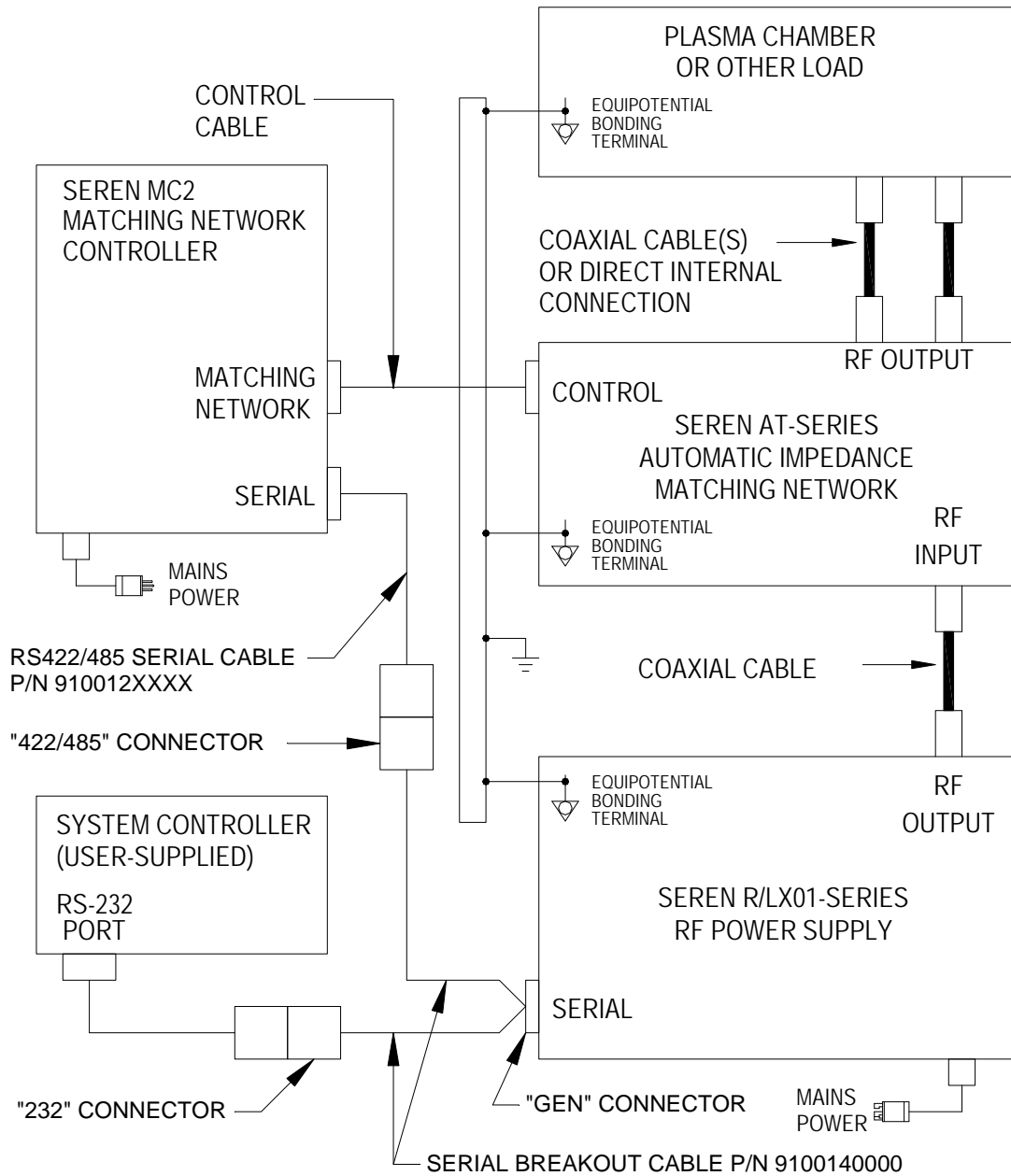

Typical MC2 "Pass-Thru" Serial Communications Configuration

For clarity, Analog Interface Connections are not shown.

Note: MC2 Controller, Matching Network, Serial Breakout Cable, RS-422/485 Cable, and System Controller are not supplied with the Seren R/LX01-Series RF Power Supply.

MC2 "Pass-thru" Operation:

To access the RF Power Supply, use the normal serial commands set as described in the **Serial Command Reference Chart** and **Serial Communications: Serial Command Details, RS232, RS422, and RS485** sections of this manual.

To access the MC2 Matching Network Controller, use the RF Power Supply's set of MC2 "Pass-Thru" serial commands. The MC2 "Pass-Thru" commands are described in the **Serial Command Reference - MC2 "Pass-Thru" Chart** and discussed in detail in the **Serial Communications: Serial Command Details, RS232, RS422, and RS485** section of this manual.

10. Equipotential Bonding Terminal



A metal stud is pressed directly into the rear panel, supplied with mating nut and washers. Connect equipotential bonding straps from system equipment and/or an earth ground to this stud to control RF circulating currents. Stud type is listed by model in the table below.



Equipotential bonding (often referred to as grounding) is used to control RF circulating currents within a system. For regulatory purposes, it is not a "Protective Earth" or "Safety Ground", even though it may be bonded to the "Protective Earth" or "Safety Ground" within the equipment or user's facility.

Model Type	Stud Type
R/L101, R/L301, R/L101MKII, R/L301MKII Manufactured on or after December 1, 2006	10-32 x 3/4", supplied with flat washer and locking hex nut
R/L101, R/L301, R/L101MKII, R/L301MKII Manufactured before December 1 2006	None.
R/L601, R/L1001	10-32 x 3/4", supplied with flat washer and locking hex nut
R/L2001, R/L3001, R4001, R/L5001, R8001, R10001, R15001	1/4-20 x 3/4", supplied with flat washer and locking hex nut

Connect the equipotential bonding strap to the system equipment's frame or bonding point with 0.01" thick, 2" wide copper strap. Keep equipotential bonding straps as short as possible.

11. Valve Connector (*Water Cooled Models Only*)

Connect the external solenoid water valve to the VALVE connector. To prevent condensation inside the R3001, the solenoid water valve disables water flow when the RF Output is “off” or when AC mains power is disabled. The valve connector pin-list is diagrammed below:

Connector Type:	4-pin male disk drive connector
Mating Connector (supplied on water valve assembly)	Housing: Molex Inc. 15-24-4048 Terminal: Molex Inc. 02-08-1202

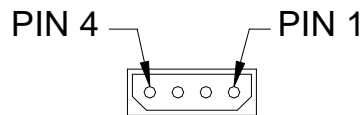

VALVE CONNECTOR

Valve Connector Pin List		
PIN	SIGNAL NAME	DESCRIPTION
1	PUP	+5VDC current-limited pull-up for water valve interlock.
2	VALVE +	+44VDC, Current limited to 1.0A (by internal re-settable fuse)
3	VALVE -	Open collector transistor output. Connects to chassis ground to enable valve. 1.0A maximum current. 50VDC maximum voltage
4	WATERINT	Optional Water Valve Interlock. Custom software option, factory configured. Standard software ignores this signal. TTL compatible logic input, active high. Apply a TTL logic high signal or connect to pin 1 to complete water valve interlock. An open circuit or TTL logic low applied to this pin will prevent the RF output from being enabled or, will disable the RF output if the RF output is enabled.

12. Coolant Water IN Port (*Water Cooled Models Only*)

Fitting Type: 3/8" N.P.T. (tapered) dry-seal, hexagonal female pipe.

Connect the output port of the solenoid water valve to the WATER IN port. Connect the coolant water supply to the input port of solenoid water valve.



Important Note: Install or remove the solenoid water valve in accordance with the water fitting installation or removal methods outlined in the Installation section.

Improper installation, removal, or over-tightening of water fittings will damage the water inlet/outlet ports and cause water leaks. The water leak may be internal and unobserved.

Damage to the water inlet/outlet ports and internal components resulting from improper fitting installation or removal are not covered by Seren IPS Inc. product warranty.

13. Coolant Water OUT Port (*Water Cooled Models Only*)

Fitting Type: 3/8" N.P.T. (tapered) dry-seal, hexagonal female pipe.

Connect the coolant water return to the WATER OUT port.



Important Note: Install or remove fittings in accordance with the water fitting installation or removal methods outlined in the Installation section.

Improper installation, removal, or over-tightening of water fittings will damage the water inlet/outlet ports and cause water leaks. The water leak may be internal and unobserved.

Damage to the water inlet/outlet ports and internal components resulting from improper fitting installation or removal are not covered by Seren IPS Inc. product warranty.

DeviceNet Interface Controls and Connector (Optional)

R/LX01-Series RF power supplies can be equipped with an optional DeviceNet™ interface. The DeviceNet interface must be specified at time of order, it is not field-installable.

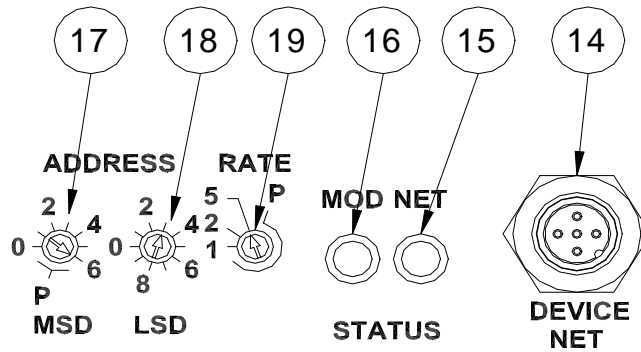

Typical DeviceNet Connector and Controls

14. DeviceNet Interface Connector (optional)

Permits remote computer control and monitoring of the R/LX01-Series RF power supply's parameters over the user's DeviceNet network. Use shielded cable to make DeviceNet interface connections.

Connector type: DeviceNet 5 pin Male circular M12 "micro" type.

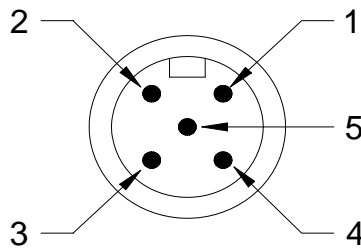

DeviceNet Connector

DeviceNet Connector Pin List		
Pin	Signal	Description
1	DRAIN	Shield drain connection. Internally connected to chassis ground
2	V+	DeviceNet termination power positive (+)
3	V-	DeviceNet termination power negative (-)
4	CAN_H	DeviceNet/CAN Bus data +
5	CAN_L	DeviceNet/CAN Bus data -

15. DeviceNet NET Status Indicator *(optional)*

After flashing during the power-up sequence, the Network (NET) status indicator shows the DeviceNet connection status, per the chart below: Additional details are explained in the DeviceNet communications section.

NET indicator	Status
Flashing Green	Waiting for connection
Solid Green	Connection Established
Solid Red	Problem with connection – check the following: <ol style="list-style-type: none"> 1. Ensure power is available on the DeviceNet Network. 2. Verify the DeviceNet network is properly terminated. 3. Verify the RF Power Supply's address is valid (0 to 63) 4. Ensure the RF Power Supply's data rate is appropriate for the DeviceNet network

16. DeviceNet MOD Status Indicator *(optional)*

After flashing during the power-up and connection sequence, the Module (MOD) status indicator should remain off. Additional details are explained in the DeviceNet communications section.

17. DeviceNet Address MSD Select Switch (Most Significant Digit) *(optional)*

Selects the most significant digit of the 2-digit DeviceNet address (“tens” column). Selection range is 0 to 6, and “P”. The “P” position should not be used.

It is good practice to ensure the address programmable parameter is set to the same value indicated by the DeviceNet Address Select switches.

18. DeviceNet Address LSD Select Switch (Least Significant Digit) *(optional)*

Selects the least significant digit of the 2-digit DeviceNet address (“ones” column). Selection range is 0 to 9.

It is good practice to ensure the address programmable parameter is set to the same value indicated by the DeviceNet Address Select switches.

19. DeviceNet Data Rate Select Switch *(optional)*

Selects the DeviceNet network data rate. Data rate selections are listed below.

It is good practice to ensure the data rate programmable parameter is set to the same value indicated by the DeviceNet RATE select switch.

RATE Switch Setting	DeviceNet Data Rate
1	125 KBPS
2	250 KBPS
5	500 KBPS
P	Not supported, do not use.

Typical System Configuration

A basic plasma processing system configuration is diagrammed below. Other system configurations are possible. For assistance with system configuration issues, contact the Seren IPS Inc. customer service department or a Seren IPS Inc. service depot. Coaxial cables, control cables, matching networks, matching network controllers, and plasma system equipment are not supplied with the RF Power Supply.

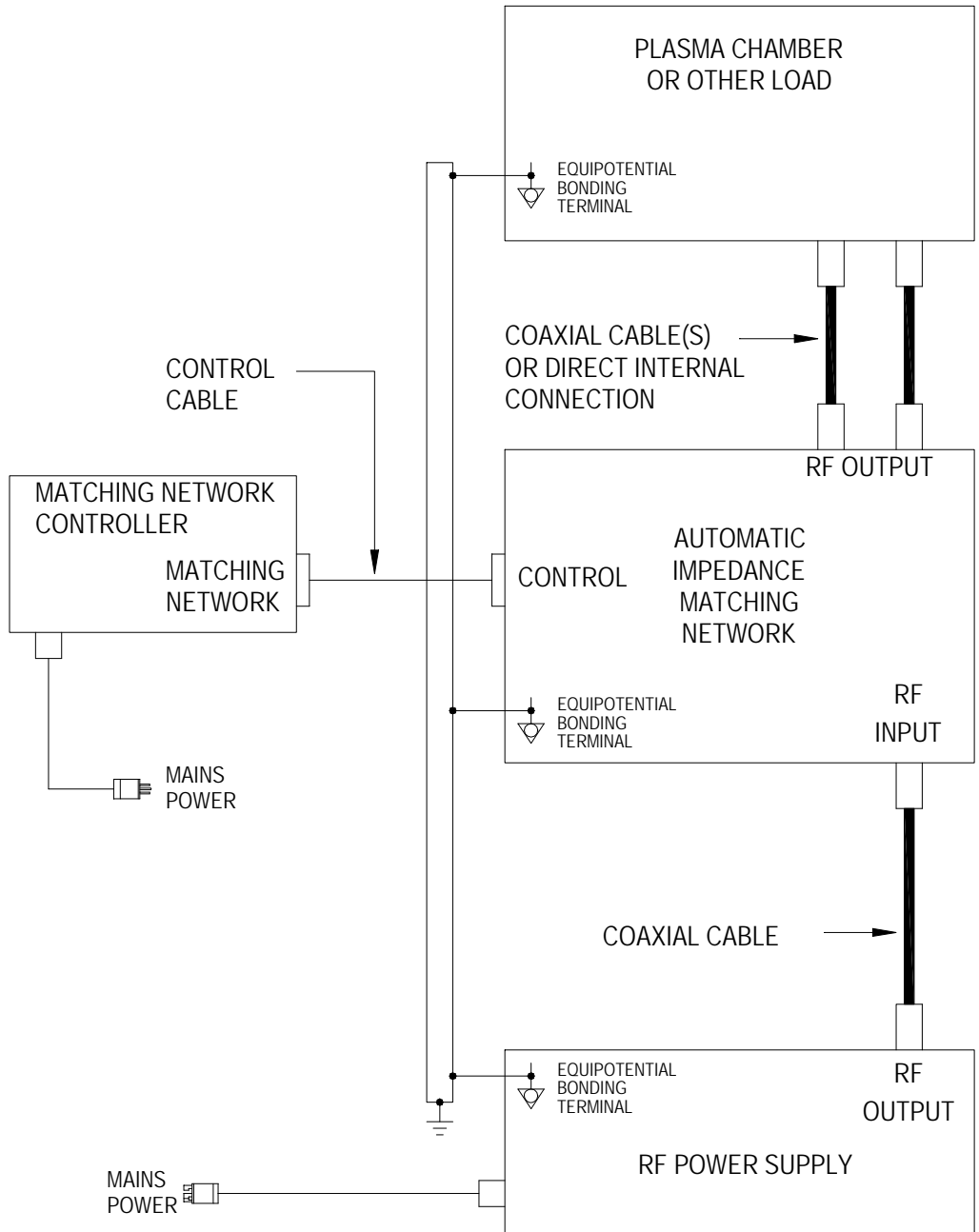

Typical Configuration - Basic Plasma Processing System

Maintenance

Seren IPS Inc R/LX01 Series Radio Frequency Power Supplies are designed to be maintenance free. There are no user maintainable assemblies inside the unit. The R/LX01-Series RF Power Supplies are designed for use in a clean environment. Environment type: Pollution Degree 2 or better.



Restricting the air inlets, blocking the exhaust fan, or installing the RF Power Supply in a dusty environment may impact the long-term reliability of the RF Power Supply.



Seren IPS R/LX01-Series RF Power Supplies are designed for operation in a clean environment (Pollution Degree 2). Operation in dirty/dusty/harsh environments (Pollution Degree 3 or greater) may result in damage to the RF Power Supply's internal components and is not covered under warranty.

Periodic Maintenance Tasks:

1. All Models: Check the air inlets and exhaust fan vents for accumulation of dust and debris. Clean the air inlets and exhaust fan with a vacuum cleaner if they appear dirty or clogged.
2. Water Cooled Models: Inspect the coolant water hoses for cracks, kinks, damage, signs of wear and deterioration. Replace degraded/questionable coolant hoses. A failed coolant hose may leak and create a hazard.
3. Water Cooled Models: Inspect coolant water connections and water valve for evidence of leakage. A leaking water connection or water valve may create a hazard.

Cleaning:

DO NOT clean the RF Power Supply when AC Mains power is applied to the unit or when the unit is connected to the AC mains. The exterior of the RF power supply may be cleaned with a soft cloth, dampened with soap and water or a mild solvent, such as alcohol. Allow time for the RF power supply to dry before re-connecting to AC Mains power.

Problem Solving

Problem Solving Chart *Front Panel Alarm Messages*

The following chart lists common problems and front panel alarm messages that may occur and the recommended solutions. Follow the suggested solutions until the problem is corrected. If the problem persists, please contact Seren IPS Inc. customer service or a Seren IPS Inc. service representative.

Condition	Suggested Solution
Front panel display does not illuminate	<p>Check the power connector – ensure it is properly seated in the AC Mains power inlet.</p> <p>Verify rear panel circuit breaker is in the “1” (on) position.</p> <p>Ensure the Analog Interface Connector is fully seated.</p> <p>Models R101, L101, R301, L301: ensure the Analog Interface “MAINS INTLK” circuit is completed – connect pin 1 to pin 14 on the analog interface connector.</p> <p>Verify the front panel power switch is in the “1” (on) position (depressed).</p>
Cannot enable the RF output by pressing the front panel RF ON/OFF button	<p>Ensure the Analog Interface Connector is fully seated and the Analog Interface “INTERLOCK” signal is at a TTL “low” state – apply a TTL “low” signal to pin 2 of the Analog Interface Connector or connect pins 2 and 15 together on Analog Interface Connector.</p> <p>Verify the unit is in “Panel” control mode – check the front panel display, line 2, left-hand side. “PANEL” should be displayed. For information on changing control mode, refer to the “Control Source” heading in the Operation section.</p>
Cannot enable the RF output by pressing the front panel RF ON/OFF button, or via the Analog or Serial Interfaces. The text “ DCV ” is shown on line 2 of the front panel display	<p>Verify the AC mains voltage is at or above the minimum operating value specified for the model type.</p>

Condition	Suggested Solution
<p>Cannot enable the RF output by pressing the front panel RF ON/OFF button, or via the Analog or Serial Interfaces. The text "CBL" and "DCV" are alternately flashing on line 2 of the front panel display</p>	<p>For OEM models equipped with an optional RF output cable interlock shroud: Verify the RF output cable is attached to the unit's RF output connector and the RF output cable interlock shroud is properly installed over the RF output connector / RF output cable and secured to the unit's chassis.</p> <p>Verify the AC mains voltage is at or above the minimum operating value specified for the model type.</p>
<p>Cannot enable the RF output by pressing the front panel RF ON/OFF button, or via the Analog or Serial Interfaces. The text "EXT" is shown on line 2 of the front panel display</p>	<p>The Analog Interface "INTERLOCK" signal is at a TTL "HIGH" state – disabling the RF output.</p> <p>Ensure the Analog Interface Connector is fully seated</p> <p>Apply a TTL "low" signal to pin 2 of the Analog Interface Connector or connect pins 2 and 15 together on Analog Interface Connector.</p>
<p>When in ANALOG control mode, the RF output power is erratic and/or fluctuates.</p>	<p>Ensure the Analog Interface connector GROUND RETURN signal (GNDI, pins 9, 16 and 17) is connected to the system common ground reference.</p> <p>Ensure the Analog Interface connector SETPOINT RETURN signal (SETRET, pin 25) is connected to the same ground reference as the SETPOINT source signal (Analog Interface Connector pin 13).</p> <p>The SETPOINT signal is a differential input. For proper operation, the GROUND RETURN (GNDI) and SETRET signals must be referenced to the same ground reference as the setpoint source signal.</p> <p>Ensure the setpoint signal is connected to the Analog Interface Connector with shielded cable.</p>
<p>The text "EXT" is shown on line 2 of the front panel display</p>	<p>The Analog Interface "INTERLOCK" signal is at a TTL "HIGH" state – disabling the RF output.</p> <p>Ensure the Analog Interface Connector is fully seated</p> <p>Apply a TTL "low" signal to pin 2 of the Analog Interface Connector or connect pins 2 and 15 together on Analog Interface Connector.</p>

Condition	Suggested Solution
<p>The text “PAC” is shown on line 2 of the front panel display</p>	<p>The Power Amplifier’s Current limit threshold has been met or exceeded. The RF Power Supply is now limiting forward power to prevent the power amplifier current from increasing.</p> <p>Check the system to see if there is a problem with the load or check the external matching network (if present) and ensure it is operating properly.</p> <p>Decrease the power setpoint.</p>
<p>The text “REF” is shown on line 2 of the front panel display</p>	<p>The Reflected Power Alarm threshold has been met or exceeded. The RF Power Supply is now limiting forward power to prevent reflected power from increasing.</p> <p>Check the system to see if there is a problem with the load, RF output cable, or check the external matching network (if present) and ensure it is operating properly.</p> <p>The Reflected Power Alarm threshold is set too low for the current process. Check the process specifications and/or the Reflected Power Alarm threshold setting (refer to the Programmable Parameters section).</p> <p>Decrease the power setpoint.</p>
<p>The text “MAX” is shown on line 2 of the front panel display</p>	<p>The Maximum Power Limit threshold has been met or exceeded.</p> <p>The Maximum Power Limit threshold is set too low for the current process. Check the process specifications and/or the Maximum Power Limit threshold setting (refer to the Programmable Parameters section).</p> <p>Decrease the power setpoint.</p>
<p>The text “TMP” is shown on line 2 of the front panel display</p>	<p>The RF Power Supply’s internal temperature sensors have detected an over-temperature condition.</p> <p>Disable the RF Output and allow the unit to cool.</p> <p><u>Air Cooled and Water-Cooled Units:</u></p> <p>Verify the chassis air inlets and air exhausts are not blocked or caked with dust or debris</p>

Condition	Suggested Solution
<p>The text “TMP” is shown on line 2 of the front panel display (continued)</p>	<p><u>Water-Cooled Units Only:</u></p> <p>Verify the solenoid water valve’s power connector is plugged into the rear panel “VALVE” connector.</p> <p>Check the solenoid water valve’s operation. The valve should emit an audible “click” when the RF Output is enabled.</p> <p>Ensure the coolant water <i>supply</i> is connected to the “IN” port on the solenoid water valve. The solenoid water valve is sensitive to flow direction.</p> <p>Verify the coolant water supply temperature is less than 40°C.</p> <p>Ensure the coolant water supply and return is connected to the unit and the coolant water is flowing.</p> <p>The coolant water flow rate may be too low:</p> <ul style="list-style-type: none"> Check for specified water flow. Check for sharp bends, pinches, or kinks in the coolant supply and return lines. Ensure the inside diameter (I.D.) of the coolant water supply and return lines are at least 3/8” ID. Check the coolant water supply and return path. Ensure the coolant water does not flow through another piece of equipment that may increase the water temperature, restrict, or cut-off the water flow.
<p>The text “HDW” is shown on line 2 of the front panel display</p>	<p>The “HDW” (hardware) alarm indicates RF Power Supply’s internal temperature sensors have detected an over-temperature condition that is above the “TMP” alarm threshold.</p> <p>It is possible for the “HDW” alarm message to be displayed when the RF output is off.</p> <p>This condition is more serious than the “TMP” alarm. The unit’s control circuits will disable the RF output (if RF output is enabled), disable internal DC power to the RF amplifier, and prevent the RF output from being enabled.</p> <p>To clear the “HDW” alarm, the RF power supply’s AC mains power must be cycled off and back on.</p> <p>If the “HDW” alarm persists, discontinue use of the RF power supply and contact Seren IPS customer service or a local Seren IPS service representative for assistance.</p>

Condition	Suggested Solution
<p>The text “XIMP” is shown on line 2 of the front panel display</p>	<p>The Excessive Impedance Detection (XIMP) feature has detected an excessive impedance condition. The XIMP alarm will clear if the XIMP condition is removed, or if the RF output is disabled and re-enabled.</p> <p>Adjust the XIMP Trigger and/or the XIMP Delay parameters to better suit the process (refer to the Programmable Parameters section).</p> <p>Disable the XIMP feature (refer to the Programmable Parameters section).</p>
<p>The RF output was on and is now off, <u>and</u> the text “XRP” is shown on line 2 of the front panel display</p>	<p>The Excessive Reflected Power (XRP) feature has detected an excessive reflected power condition. Reflected power has exceeded the threshold setting and the XRP feature has disabled the RF output.</p> <p>Investigate the source or system condition causing the reflected power. Ensure there are no system abnormalities causing a problem.</p> <p>Check the system to see if there is a problem with the load, RF output cable, or check the external matching network (if present) and ensure it is operating properly.</p> <p>Adjust the XRP Threshold and/or the XRP Delay parameters to better suit the process (refer to the Programmable Parameters section).</p> <p>Decrease the power setpoint.</p> <p>Disable the XRP feature (refer to the Programmable Parameters section).</p> <p><u>Note:</u> Once the cause of the Excessive Reflected Power condition is resolved, re-enabling the RF output or a power down/power up cycle will clear the “XRP” alarm message</p>
<p>The text “UNBAL” is shown on line 2 of the front panel display.</p>	<p>The RF Power Supply’s control circuits detected a fault with one or more of the internal RF Power Amplifiers. When an UNBAL fault is detected, the control circuits will disable the RF output.</p> <p><u>Do not re-enable the RF output or continue to use the RF power supply.</u> Operating the RF power supply after an UNBAL alarm condition may seriously damage the unit and void the warranty.</p> <p>Contact Seren IPS customer service or an authorized Seren IPS service depot for assistance.</p>

Condition	Suggested Solution
<p>The text "DIS" is shown on line 2 of the front panel display</p>	<p>An excessive power dissipation limit condition has occurred and output power is being limited/folded back to protect the RF amplifier's output transistors.</p> <p>This is often caused by the load drawing excessive current, even if reflected power is low and/or the load otherwise appears to be matched.</p> <p>To relieve the dissipation limit condition, try the following:</p> <ol style="list-style-type: none"> 1. A slight adjustment of the load's tune point (via a matching network) may clear the alarm. Manually re-position the load (shunt) and tune (series) capacitors and see if another tune point (maximized forward power, 0W or a small amount of reflected power) can be obtained without a "DIS" alarm message. 2. The matching network may have reached a "false tune" point in automatic mode. Manually re-position the matching network's load and tune capacitors and see if another tune point (maximized forward power, 0W or a small amount of reflected power) can be found. Re-adjust/re-null/touch-up the calibration of the matching network's Phase/Magnitude sensor. 3. Lengthen or shorten the coaxial cable between the RF power supply and the matching network/load. Add/subtract approximately 1ft to 6ft of cable length and re-try.
<p>The text "WTR" is shown on line 2 of the front panel display</p>	<p>Applies to Water Cooled Units, Models R5001, L5001, R10001, and R15001 manufactured after April 1 2009 only.</p> <p>Insufficient coolant water flow has been detected. If the RF output was enabled when insufficient coolant water flow is detected, the RF output is automatically disabled and the message "WTR" is displayed on the unit's front panel display for 30 seconds.</p> <p>If there is insufficient water flow available when the RF output is enabled, the RF output will be available for a short period of time while the water flow sensor tests for water flow, then the sensor will automatically disable the RF output and display the "WTR" message on the unit's front panel display.</p>

Condition	Suggested Solution
	<p>The coolant water flow rate may be too low: Ensure the coolant water supply and return is connected to the unit and the coolant water is flowing. Check coolant water supply or coolant water circulation system and ensure proper operation. Check coolant water hoses for kinks or obstructions. Check other equipment in the coolant water path and ensure that equipment is not reducing or blocking the water flow.</p> <p>The coolant water may be flowing in the wrong direction.</p> <ol style="list-style-type: none"> 1. The coolant water supply must be connected to the solenoid valve assembly's "IN" port. 2. R5001 and L5001 models only: The solenoid valve's "OUT" port must be connected to the RF power supply's "Water In" fitting. 3. R10001 and R15001 models only: The solenoid valve's "OUT" port must be connected to the flow switch's "IN" port. The flow switch's "OUT" port must be connected to the RF power supply's "Water In" fitting. An arrow on the body of the flow switch indicates proper water flow direction. 4. The RF power supply's "Water Out" fitting must be connected to the water system's "return". <p>The solenoid water valve assembly's electrical connections may not be connected the RF power supply. Ensure the solenoid water valve assembly is properly connected to the unit's rear panel "Valve" connector</p> <p>The solenoid water valve assembly may be faulty. Ensure the solenoid water valve is operating properly. If the valve is not operating properly, replace the water valve assembly.</p>
<p>The text "CHK DN CARD" is shown on line 3 of the front panel display</p>	<p>Applicable only to R/L101MKII, R/L301MKII, R/L601 and R/L1001 models with <i>optional</i> DeviceNet Interface. The internal DeviceNet Interface card is not responding. Contact Seren IPS customer service or an authorized Seren IPS service depot for assistance.</p>

Condition	Suggested Solution
<p>The text "COMM ERROR" is shown on line 3 of the front panel display</p>	<p>Applicable only to R/L101MKII, R/L301MKII, R/L601 and R/L1001 models with <i>optional</i> DeviceNet Interface.</p> <p>A DeviceNet communications error has occurred.</p> <ol style="list-style-type: none"> 1. Ensure there is proper power available on the DeviceNet network. 2. Verify the DeviceNet network is properly terminated 3. Confirm the RF Power Supply's address and data rate settings are valid and the DeviceNet address is not duplicated elsewhere on the DeviceNet network.
<p>The text "No Master" is shown on line 3 of the front panel display</p>	<p>Applicable only to R/L101MKII, R/L301MKII, R/L601 and R/L1001 models with <i>optional</i> DeviceNet Interface.</p> <p>The RF Power Supply is waiting to be contacted by a DeviceNet Master.</p>
<p>The text "On-Line" is shown on line 3 of the front panel display</p>	<p>Applicable only to R/L101MKII, R/L301MKII, R/L601 and R/L1001 models with <i>optional</i> DeviceNet Interface.</p> <p>The RF Power Supply is under the control of a DeviceNet Master.</p>
<p>The front panel display is off and the front panel power switch is in the "off" position, but there is the sound of a fan operating.</p>	<p>This is normal. The RF Power Supply is in "stand-by" mode. The display, internal DC Power supply's output, and RF circuits are disabled but the internal DC power supply's fan is still operating.</p> <p>Setting the rear panel circuit breaker to the "0" (off) position will completely disable the internal DC power supply.</p>

Technical Data

Specifications and other technical data are listed by model type, and where applicable, by Seren IPS Inc. part number.

RF Power Supply Identification

Seren IPS Inc. manufactures multiple variations of its RF Power Supplies. Variations include output power, output frequency, AC mains voltage, and OEM specific hardware and software features. The basic model type is imprinted on the front panel. Detailed information about the RF Power Supply is located on the ratings plate located on the side panel or top cover.

Depending on the configuration of the RF Power supply, the version of installed software may or may not be displayed on the front panel when the unit is powered-on.

The following configuration information is located on the ratings plate:

- Model Type
- Manufacture Date
- Seren IPS Inc. Part Number (10-digit)
- Serial Number
- Customer Part Number (CPN) (optional)
- AC Mains Voltage, AC Mains Frequency, AC Mains Current
- AC Mains Phase (single or 3-phase), AC Mains Input Power
- Rated Output Power
- Rated Output Frequency
- Firmware Version

Note: The output frequency range of variable frequency models may be limited per customer or OEM configuration requirements. Output power may be limited per customer or OEM configuration requirements.

R101 Specifications Transformer Power Supply (P/N 9600600002/9600600003)
(Discontinued)

AC Mains Input Power	<p>Voltage Taps: 98V, 115V, 208V, or 220V Nominal; Single-phase, factory configured.</p> <p>Specify desired AC mains voltage at time of order. Voltage taps are set to the most appropriate setting at the factory. Input power is not field-configurable.</p> <p>Frequency: 47-63 HZ</p> <p>Power required: 750VA Maximum</p> <p>Over-current Protection: Rear Panel Circuit Breaker, 2x 3A ¼"x1-1/4" time-delay fuses.</p> <p>Current (FLA): 98-125V: 10A Maximum 198-250V: 5A Maximum</p> <p>Inrush Current: 36.2A Nominal</p> <p>Short Circuit Current Rating (SCCR) 10KA</p> <p>Note: For SEMI S2 compliance, the system power distribution panel or system integrator must supply an over-current protection device (fuse or circuit breaker) with a minimum interrupting capacity of 10,000A (10,000AIC).</p>
Power Cord Supplied (Detachable):	<p>98-125V Applications: 14 AWG, 3 Conductor, Type SJT, 2m length, with IEC320-C13 female connector and NEMA 5-15P male plug.</p> <p>198-250V Applications: 14 AWG, 3 Conductor, Type SJT, 2m length, with IEC320-C13 female connector and NEMA L6-15P male plug.</p>
Output:	<p>Power: High Range: 0 to 100 Watts into 50 Ohms Low Range: 0 to 10 Watts into 50 Ohms</p> <p>Maximum Reflected Power: 50 Watts</p> <p>Frequency: 13.56 MHz, Crystal-Controlled</p> <p>Leveling: Forward Power, Load (Net) Power, External Feedback (RF or DC Probe)</p> <p>Power Stability: 0.5% Long Term</p> <p>Output Impedance: 50 Ohms, +/-5 Ohms Nominal</p>

R101 Specifications Transformer Power Supply (P/N 9600600002/9600600003)
(Discontinued)

Metering Accuracy: (Forward Power)	+/-3% of Reading, +/- 1 Watt
Temperature Coefficient:	0.25% per °C
Forward Power Regulation:	+/- 1% into 50 Ohms
Load Tolerance:	No oscillation or failure into a mismatch condition.
Protection:	Forward power limits on current, transistor power dissipation, and excessive reflected power. Unit is short-circuit and open-circuit protected. Unit is thermally protected.
Spurious Radiation:	Designed to meet or exceed FCC requirements.
Harmonics:	-50dBc
Noise, Hum, and Ripple:	-50dBc
Pulsing:	20Hz to 10KHz, 1-Hz Steps; 0 to 100% duty cycle; 50 micro-second minimum pulse
Environment: Operating:	Ambient Temperature: +5°C to +40°C Relative Humidity: 10% to 90% non-condensing, non-icing Atmospheric Pressure: 683 mBar minimum (approx 3000m above sea level) Pollution Degree: 2 or cleaner.
Storage:	Ambient Temperature: -25°C to +55°C Relative Humidity: 5% to 95%, non-condensing Atmospheric Pressure: 585 mBar minimum (approx 4000m above sea level)
Transportation:	Ambient Temperature: -25°C to +70°C Relative Humidity: 95% Maximum absolute humidity when unit temperature directly decreases from +70°C to +15°C Atmospheric Pressure: 480 mBar minimum (approx 5000m above sea level)

R101 Specifications Transformer Power Supply (P/N 9600600002/9600600003)
(Discontinued)

Cooling: Forced Air, 110 CFM (51.91 L/Sec), intake at sides, exhaust at rear panel.
Observe specified panel clearances and mounting instructions.

Interface Connections:

Analog Interface:	25 pin Female D-Sub Connector
Serial Interface:	9 pin Female D-Sub Connector
DCP (Probe) Input: (Optional)	Female type BNC connector, 0 to -10VDC
CEX Input:	Female type BNC connector, 3 to 8V Peak-to-Peak sine wave, 50 Ohms Nominal Impedance at specified operating frequency.
CEX Output:	Female type BNC connector, 5 to 8V Peak-to-Peak into 50 Ohms at specified operating frequency.

Power Monitor Scaling:

Forward Power Monitor	Monitor output is linearly proportional to 0 to 100 Watts of forward power. Output scaling is 5.0VDC at 100 Watts (50mV/Watt) or 10.0VDC at 100 Watts (100mV/Watt), depending on the analog voltage range selected. (Default scaling)
Reflected Power Monitor	Monitor output is linearly proportional to 0 to 100 Watts of reflected power. Output scaling is 5.0VDC at 100 Watts (50mV/Watt) or 10.0VDC at 100 Watts (100mV/Watt), depending on the analog voltage range selected. (Default scaling)

Analog Setpoint Sensitivity: In Power Control mode, analog setpoint sensitivity is 100 Watts at 5.0VDC (50mV per Watt) or 100 Watts at 10.0VDC (100mV per Watt), depending on the analog voltage range selected.

R101 Specifications Transformer Power Supply (P/N 9600600002/9600600003)
(Discontinued)

Labels:	Safety:	Per customer requirements. Labels may include Hazardous Voltage, Heavy Object
	Identification:	Seren IPS Inc. part number, serial number, and customer part number (optional), RF output frequency
Supplied Accessories:	Power Cord Product Information CD-ROM	
Dimensions inch (mm):	5.25 (133.35) High x 9.50 (241.30) Wide x 18.35 (466.09) Deep. Width without ½-Rack Mounting Brackets: 8.00 (203.2)	
Weight:	43 Lbs (19.5Kg)	

R101 Specifications Switching Power Supply (P/N 9600600004/9600600005)
(Discontinued)

AC Mains Voltage Ranges: 100-125V or 200-240V Nominal, Single-phase.
 Input Power Specify desired AC mains voltage range at time of order. Voltage range is factory configured. Input power is not field-configurable.

Frequency: 47-63 HZ

Power required: 750VA Maximum

Over-current Protection: Rear Panel Circuit Breaker,
2x 3A ¼"x1-1/4" time-delay fuses.

Current (FLA): 100-125V: 10A Maximum
200-240V: 5A Maximum

Inrush Current: 36.2A Nominal

Short Circuit Current Rating (SCCR) 10KA

Note: For SEMI S2 compliance, the system power distribution panel or system integrator must supply an over-current protection device (fuse or circuit breaker) with a minimum interrupting capacity of 10,000A (10,000AIC).

Power Cord Supplied (Detachable):

100-125V Applications: 14 AWG, 3 Conductor, Type SJT, 2m length, with IEC320-C13 female connector and NEMA 5-15P male plug.

200-240V Applications: 14 AWG, 3 Conductor, Type SJT, 2m length, with IEC320-C13 female connector and NEMA L6-15P male plug.

Output:

Power: High Range: 0 to 100 Watts into 50 Ohms
Low Range: 0 to 10 Watts into 50 Ohms

Maximum Reflected Power: 50 Watts

Frequency: 13.56 MHz, Crystal-Controlled

Leveling: Forward Power, Load (Net) Power, External Feedback (RF or DC Probe)

Power Stability: 0.5% Long Term

Output Impedance: 50 Ohms, +/-5 Ohms Nominal

R101 Specifications Switching Power Supply (P/N 9600600004/9600600005)
(Discontinued)

Metering Accuracy: (Forward Power)	+/-3% of Reading, +/- 1 Watt
Temperature Coefficient:	0.25% per °C
Forward Power Regulation:	+/- 1% into 50 Ohms
Load Tolerance:	No oscillation or failure into a mismatch condition.
Protection:	Forward power limits on current, transistor power dissipation, and excessive reflected power. Unit is short-circuit and open-circuit protected. Unit is thermally protected.
Spurious Radiation:	Designed to meet or exceed FCC requirements.
Harmonics:	-50dBc
Noise, Hum, and Ripple:	-50dBc
Pulsing:	20Hz to 10KHz, 1-Hz Steps; 0 to 100% duty cycle; 50 micro-second minimum pulse
Environment: Operating:	Ambient Temperature: +5°C to +40°C Relative Humidity: 10% to 90% non-condensing, non-icing Atmospheric Pressure: 683 mBar minimum (approx 3000m above sea level) Pollution Degree: 2 or cleaner.
Storage:	Ambient Temperature: -25°C to +55°C Relative Humidity: 5% to 95%, non-condensing Atmospheric Pressure: 585 mBar minimum (approx 4000m above sea level)
Transportation:	Ambient Temperature: -25°C to +70°C Relative Humidity: 95% Maximum absolute humidity when unit temperature directly decreases from +70°C to +15°C Atmospheric Pressure: 480 mBar minimum (approx 5000m above sea level)

R101 Specifications Switching Power Supply (P/N 9600600004/9600600005)
(Discontinued)

Cooling:	Forced Air, 110 CFM (51.91 L/Sec), intake at sides, exhaust at rear panel. Observe specified panel clearances and mounting instructions.	
Interface Connections:	Analog Interface:	25 pin Female D-Sub Connector
	Serial Interface:	9 pin Female D-Sub Connector
	DCP (Probe) Input: (Optional)	Female type BNC connector, 0 to -10VDC
	CEX Input:	Female type BNC connector, 3 to 8V Peak-to-Peak sine wave, 50 Ohm Nominal Impedance at specified operating frequency.
	CEX Output:	Female type BNC connector, 5 to 8V Peak-to-Peak, into 50 Ohms at specified operating frequency.
Power Monitor Scaling:	Forward Power Monitor	Monitor output is linearly proportional to 0 to 100 Watts of forward power. Output scaling is 5.0VDC at 100 Watts (50mV/Watt) or 10.0VDC at 100 Watts (100mV/Watt), depending on the analog voltage range selected. (Default scaling)
	Reflected Power Monitor	Monitor output is linearly proportional to 0 to 100 Watts of reflected power. Output scaling is 5.0VDC at 100 Watts (50mV/Watt) or 10.0VDC at 100 Watts (100mV/Watt), depending on the analog voltage range selected. (Default scaling)
Analog Setpoint Sensitivity:	In Power Control mode, analog setpoint sensitivity is 100 Watts at 5.0VDC (50mV per Watt) or 100 Watts at 10.0VDC (100mV per Watt), depending on the analog voltage range selected.	

R101 Specifications Switching Power Supply (P/N 9600600004/9600600005)
(Discontinued)

Labels:	Safety:	Per customer requirements. Labels may include Hazardous Voltage, Heavy Object
	Identification:	Seren IPS Inc. part number, serial number, and customer part number (optional), RF output frequency
Supplied Accessories:	Power Cord Product Information CD-ROM	
Dimensions inch (mm):	5.25 (133.35) High x 9.50 (241.30) Wide x 18.35 (466.09) Deep. Width without 1/2-Rack Mounting Brackets: 8.00 (203.2)	
Weight:	27.5 Lbs (12.47Kg)	

R101MKII Specifications

Metering Accuracy: (Forward Power)	+/-2% of Reading, +/- 1 Watt
Temperature Coefficient:	0.25% per °C
Forward Power Regulation:	+/- 1% into 50 Ohms
Load Tolerance:	No oscillation or failure into a mismatch condition.
Protection:	Forward power limits on current, transistor power dissipation, and excessive reflected power. Unit is short-circuit and open-circuit protected. Unit is thermally protected.
Spurious Radiation:	Designed to meet or exceed FCC requirements.
Harmonics:	-50dBc
Noise, Hum, and Ripple:	-50dBc
Pulsing:	20Hz to 10KHz, 1-Hz Steps; 0 to 100% duty cycle; 50 micro-second minimum pulse
Environment:	<p>Operating: Ambient Temperature: +5°C to +40°C Relative Humidity: 10% to 90% non-condensing, non-icing Atmospheric Pressure: 683 mBar minimum (approx 3000m above sea level) Pollution Degree: 2 or cleaner.</p> <p>Storage: Ambient Temperature: -25°C to +55°C Relative Humidity: 5% to 95%, non-condensing Atmospheric Pressure: 585 mBar minimum (approx 4000m above sea level)</p> <p>Transportation: Ambient Temperature: -25°C to +70°C Relative Humidity: 95% Maximum absolute humidity when unit temperature directly decreases from +70°C to +15°C Atmospheric Pressure: 480 mBar minimum (approx 5000m above sea level)</p>

R101MKII Specifications

Cooling:	Forced Air, 123 CFM (58.05 L/Sec), intake at sides, exhaust at rear panel. Observe specified panel clearances and mounting instructions.	
Interface Connections:	Analog Interface:	25 pin Female D-Sub Connector
	Serial Interface:	9 pin Female D-Sub Connector
	DCP (Probe) Input: (Optional)	Female type BNC connector, 0 to -10VDC
	CEX Input:	Female type BNC connector, 3 to 8V Peak-to-Peak sine wave, 50 Ohms Nominal Impedance at specified operating frequency.
	CEX Output:	Female type BNC connector, 5 to 8V Peak-to-Peak into 50 Ohms at specified operating frequency.
Power Monitor Scaling:	Forward Power Monitor	Monitor output is linearly proportional to 0 to 100 Watts of forward power. Output scaling is 5.0VDC at 100 Watts (50mV/Watt) or 10.0VDC at 100 Watts (100mV/Watt), depending on the analog voltage range selected. (Default scaling)
	Reflected Power Monitor	Monitor output is linearly proportional to 0 to 100 Watts of reflected power. Output scaling is 5.0VDC at 100 Watts (50mV/Watt) or 10.0VDC at 100 Watts (100mV/Watt), depending on the analog voltage range selected. (Default scaling)
Analog Setpoint Sensitivity:	In Power Control mode, analog setpoint sensitivity is 100 Watts at 5.0VDC (50mV per Watt) or 100 Watts at 10.0VDC (100mV per Watt), depending on the analog voltage range selected.	

R101MKII Specifications

Labels:	Safety:	Per customer requirements. Labels may include Hazardous Voltage, Heavy Object
	Identification:	Seren IPS Inc. part number, serial number, and customer part number (optional), RF output frequency
Battery:	Internal, 3V 255mAh, 23mm Coin Style, Type BR2330 or CR2330 (For retention of user-configurable settings)	
Supplied Accessories:	Power Cord Product Information CD-ROM	
Dimensions inch (mm):	5.25 (133.35) High x 9.50 (241.30) Wide x 18.35 (466.09) Deep. Width without 1/2-Rack Mounting Brackets: 8.00 (203.2)	
Weight:	22.5 Lbs (10.2Kg)	

L101MKII Specifications

Output Impedance:	50 Ohms, +/-5 Ohms Nominal
Metering Accuracy: (Forward Power)	+/-2% of Reading, +/- 1 Watt
Temperature Coefficient:	0.25% per °C
Forward Power Regulation:	+/- 1% into 50 Ohms
Load Tolerance:	No oscillation or failure into a mismatch condition.
Protection:	Forward power limits on current, transistor power dissipation, and excessive reflected power. Unit is short-circuit and open-circuit protected. Unit is thermally protected.
Spurious Radiation:	Designed to meet or exceed FCC requirements.
Harmonics:	Equal to or less than -40dBc at maximum output frequency
Noise, Hum, and Ripple:	-50dBc
Pulsing:	20Hz to 10KHz, 1-Hz Steps; 0 to 100% duty cycle; 50 micro-second minimum pulse
Environment:	<p>Operating: Ambient Temperature: +5°C to +40°C Relative Humidity: 10% to 90% non-condensing, non-icing Atmospheric Pressure: 683 mBar minimum (approx 3000m above sea level) Pollution Degree: 2 or cleaner.</p> <p>Storage: Ambient Temperature: -25°C to +55°C Relative Humidity: 5% to 95%, non-condensing Atmospheric Pressure: 585 mBar minimum (approx 4000m above sea level)</p> <p>Transportation: Ambient Temperature: -25°C to +70°C Relative Humidity: 95% Maximum absolute humidity when unit temperature directly decreases from +70°C to +15°C Atmospheric Pressure: 480 mBar minimum (approx 5000m above sea level)</p>

L101MKII Specifications

Cooling:	Forced Air, 123 CFM (58.05 L/Sec), intake at sides, exhaust at rear panel. Observe specified panel clearances and mounting instructions.	
Interface Connections:	Analog Interface:	25 pin Female D-Sub Connector
	Serial Interface:	9 pin Female D-Sub Connector
	DCP (Probe) Input: (Optional)	Female type BNC connector, 0 to -10VDC
	CEX Input:	Female type BNC connector, 3 to 8V Peak-to-Peak sine wave, 50 Ohms Nominal Impedance at specified operating frequency.
	CEX Output:	Female type BNC connector, 5 to 8V Peak-to-Peak into 50 Ohms at specified operating frequency.
Power Monitor Scaling:	Forward Power Monitor	Monitor output is linearly proportional to 0 to 100 Watts of forward power. Output scaling is 5.0VDC at 100 Watts (50mV/Watt) or 10.0VDC at 100 Watts (100mV/Watt), depending on the analog voltage range selected. (Default scaling)
	Reflected Power Monitor	Monitor output is linearly proportional to 0 to 100 Watts of reflected power. Output scaling is 5.0VDC at 100 Watts (50mV/Watt) or 10.0VDC at 100 Watts (100mV/Watt), depending on the analog voltage range selected. (Default scaling)
Analog Setpoint Sensitivity:	In Power Control mode, analog setpoint sensitivity is 100 Watts at 5.0VDC (50mV per Watt) or 100 Watts at 10.0VDC (100mV per Watt), depending on the analog voltage range selected.	
Labels:	Safety:	Per customer requirements. Labels may include Hazardous Voltage, Heavy Object
	Identification:	Seren IPS Inc. part number, serial number, and customer part number (optional), RF output frequency

L101MKII Specifications

Battery: Internal, 3V 255mAh, 23mm Coin Style, Type BR2330 or CR2330
(For retention of user-configurable settings)

Supplied Power Cord
Accessories: Product Information CD-ROM

Dimensions 5.25 (133.35) High x 9.50 (241.30) Wide x 18.35 (466.09) Deep.
inch (mm): Width without ½-Rack Mounting Brackets: 8.00 (203.2)

Weight: 22.5 Lbs (10.2Kg)

R301 Specifications (Discontinued, Part Number Series 960060XXXX)

AC Mains Input Power	<p>Voltage Taps: 98V, 115V, 208V, or 220V Nominal; Single-phase, factory configured.</p> <p>Specify desired AC mains voltage at time of order. Voltage taps are set to the most appropriate setting at the factory. Input power is not field-configurable.</p> <p>Frequency: 47-63 HZ</p> <p>Power required: 750VA Maximum</p> <p>Over-current Protection: Rear Panel Circuit Breaker, 2x 3A 1/4"x1-1/4" time-delay fuses.</p> <p>Current (FLA): 98-125V: 10A Maximum 198-250V: 5A Maximum</p> <p>Inrush Current: 36.2A Nominal</p> <p>Short Circuit Current Rating (SCCR) 10KA</p> <p>Note: For SEMI S2 compliance, the system power distribution panel or system integrator must supply an over-current protection device (fuse or circuit breaker) with a minimum interrupting capacity of 10,000A (10,000AIC).</p>
Power Cord Supplied (Detachable):	<p>98-125V Applications: 14 AWG, 3 Conductor, Type SJT, 2m length, with IEC320-C13 female connector and NEMA 5-15P male plug.</p> <p>198-250V Applications: 14 AWG, 3 Conductor, Type SJT, 2m length, with IEC320-C13 female connector and NEMA L6-15P male plug.</p>
Output:	<p>Power: High Range: 0 to 300 Watts into 50 Ohms Low Range: 0 to 30 Watts into 50 Ohms</p> <p>Maximum Reflected Power: 50 Watts</p> <p>Frequency: 13.56 MHz, Crystal-Controlled</p> <p>Leveling: Forward Power, Load (Net) Power, External Feedback (RF or DC Probe)</p> <p>Power Stability: 0.5% Long Term</p> <p>Output Impedance: 50 Ohms, +/-5 Ohms Nominal</p> <p>Metering Accuracy: +/-3% of Reading, +/- 1 Watt (Forward Power)</p>

R301 Specifications (Discontinued, Part Number Series 960060XXXX)

Temperature Coefficient:	0.25% per °C
Forward Power Regulation:	+/- 1% into 50 Ohms
Load Tolerance:	No oscillation or failure into a mismatch condition.
Protection:	Forward power limits on current, transistor power dissipation, and excessive reflected power. Unit is short-circuit and open-circuit protected. Unit is thermally protected.
Spurious Radiation:	Designed to meet or exceed FCC requirements.
Harmonics:	-50dBc
Noise, Hum, and Ripple:	-50dBc
Pulsing:	20Hz to 10KHz, 1-Hz Steps; 0 to 100% duty cycle; 50 micro-second minimum pulse
Environment: Operating:	Ambient Temperature: +5°C to +40°C Relative Humidity: 10% to 90% non-condensing, non-icing Atmospheric Pressure: 683 mBar minimum (approx 3000m above sea level) Pollution Degree: 2 or cleaner.
Storage:	Ambient Temperature: -25°C to +55°C Relative Humidity: 5% to 95%, non-condensing Atmospheric Pressure: 585 mBar minimum (approx 4000m above sea level)
Transportation:	Ambient Temperature: -25°C to +70°C Relative Humidity: 95% Maximum absolute humidity when unit temperature directly decreases from +70°C to +15°C Atmospheric Pressure: 480 mBar minimum (approx 5000m above sea level)

R301 Specifications (Discontinued, Part Number Series 960060XXXX)

Cooling:	Forced Air, 110 CFM (51.91 L/Sec), intake at sides, exhaust at rear panel. Observe specified panel clearances and mounting instructions.	
Interface Connections:	Analog Interface:	25 pin Female D-Sub Connector
	Serial Interface:	9 pin Female D-Sub Connector
	DCP (Probe) Input: (Optional)	Female type BNC connector, 0 to -10VDC
	CEX Input:	Female type BNC connector, 3 to 8V Peak-to-Peak sine wave, 50 Ohms Nominal Impedance at specified operating frequency.
	CEX Output:	Female type BNC connector, 5 to 8V Peak-to-Peak into 50 Ohms at specified operating frequency.
Power Monitor Scaling:	Forward Power Monitor	Monitor output is linearly proportional to 0 to 300 Watts of forward power. Output scaling is 5.0VDC at 300 Watts (16.6mV/Watt) or 10.0VDC at 300 Watts (33.3mV/Watt), depending on the analog voltage range selected. (Default scaling)
	Reflected Power Monitor	Monitor output is linearly proportional to 0 to 100 Watts of reflected power. Output scaling is 5.0VDC at 100 Watts (50mV/Watt) or 10.0VDC at 100 Watts (100mV/Watt), depending on the analog voltage range selected. (Default scaling)
Analog Setpoint Sensitivity:	In Power Control mode, analog setpoint sensitivity is 300 Watts at 5.0VDC (16.6mV per Watt) or 300 Watts at 10.0VDC (33.3mV per Watt), depending on the analog voltage range selected.	
Labels:	Safety:	Per customer requirements. Labels may include Hazardous Voltage, Heavy Object
	Identification:	Seren IPS Inc. part number, serial number, and customer part number (optional), RF output frequency

R301 Specifications (Discontinued, Part Number Series 960060XXXX)

Supplied Power Cord

Accessories: Product Information CD-ROM

Dimensions 5.25 (133.35) High x 9.50 (241.30) Wide x 18.35 (466.09) Deep.
inch (mm): Width without ½-Rack Mounting Brackets: 8.00 (203.2)

Weight: 43 Lbs (19.5Kg)

R301MKII Specifications

AC Mains	Nominal Rated Voltage: 100-240VAC Single Phase (universal input)
Input Power	Operating Voltage Range: 90-264VAC, Single Phase (universal input)
	There are no transformer taps to configure.
	AC mains voltage specified at time of order determines supplied power cord
Frequency:	47-63 HZ
Power required:	750VA Maximum
Over-current Protection:	Rear Panel Circuit Breaker, 10A 2x 3A ¼"x1-1/4" time-delay fuses.
Current (FLA):	100-125V: 10A Maximum 200-240V: 5A Nominal
Inrush Current:	35A Maximum
Short Circuit Current Rating (SCCR)	10KA

Note: For SEMI S2 compliance, the system power distribution panel or system integrator must supply an over-current protection device (fuse or circuit breaker) with a minimum interrupting capacity of 10,000A (10,000AIC).

Power Cord Supplied (Detachable):	100-125V Applications: 14 AWG, 3 Conductor, Type SJT, 2m length, with IEC320-C13 female connector and NEMA 5-15P male plug.
	200-240V Applications: 14 AWG, 3 Conductor, Type SJT, 2m length, with IEC320-C13 female connector and NEMA L6-15P male plug.

Output:	Power:	High Range: 0 to 300 Watts into 50 Ohms Low Range: 0 to 30 Watts into 50 Ohms
	Maximum Reflected Power:	50 Watts
	Frequency:	13.56MHz, Fixed
	Leveling:	Forward Power, Load (Net) Power, External Feedback (RF or DC Probe)
	Power Stability:	0.5% Long Term
	Output Impedance:	50 Ohms, +/-5 Ohms Nominal

R301MKII Specifications

Metering Accuracy: (Forward Power)	+/-2% of Reading, +/- 1 Watt
Temperature Coefficient:	0.25% per °C
Forward Power Regulation:	+/- 1% into 50 Ohms
Load Tolerance:	No oscillation or failure into a mismatch condition.
Protection:	Forward power limits on current, transistor power dissipation, and excessive reflected power. Unit is short-circuit and open-circuit protected. Unit is thermally protected.
Spurious Radiation:	Designed to meet or exceed FCC requirements.
Harmonics:	-50dBc
Noise, Hum, and Ripple:	-50dBc
Pulsing:	20Hz to 10KHz, 1-Hz Steps; 0 to 100% duty cycle; 50 micro-second minimum pulse
Environment:	<p>Operating: Ambient Temperature: +5°C to +40°C Relative Humidity: 10% to 90% non-condensing, non-icing Atmospheric Pressure: 683 mBar minimum (approx 3000m above sea level) Pollution Degree: 2 or cleaner.</p> <p>Storage: Ambient Temperature: -25°C to +55°C Relative Humidity: 5% to 95%, non-condensing Atmospheric Pressure: 585 mBar minimum (approx 4000m above sea level)</p> <p>Transportation: Ambient Temperature: -25°C to +70°C Relative Humidity: 95% Maximum absolute humidity when unit temperature directly decreases from +70°C to +15°C Atmospheric Pressure: 480 mBar minimum (approx 5000m above sea level)</p>

R301MKII Specifications

Cooling:	Forced Air, 123 CFM (58.05 L/Sec), intake at sides, exhaust at rear panel. Observe specified panel clearances and mounting instructions.	
Interface Connections:	Analog Interface:	25 pin Female D-Sub Connector
	Serial Interface:	9 pin Female D-Sub Connector
	DCP (Probe) Input: (Optional)	Female type BNC connector, 0 to -10VDC
	CEX Input:	Female type BNC connector, 3 to 8V Peak-to-Peak sine wave, 50 Ohms Nominal Impedance at specified operating frequency.
	CEX Output:	Female type BNC connector, 5 to 8V Peak-to-Peak into 50 Ohms at specified operating frequency.
Power Monitor Scaling:	Forward Power Monitor	Monitor output is linearly proportional to 0 to 300 Watts of forward power. Output scaling is 5.0VDC at 300 Watts (16.6mV/Watt) or 10.0VDC at 300 Watts (33.3mV/Watt), depending on the analog voltage range selected. (Default scaling)
	Reflected Power Monitor	Monitor output is linearly proportional to 0 to 100 Watts of reflected power. Output scaling is 5.0VDC at 100 Watts (50mV/Watt) or 10.0VDC at 100 Watts (100mV/Watt), depending on the analog voltage range selected. (Default scaling)
Analog Setpoint Sensitivity:	In Power Control mode, analog setpoint sensitivity is 300 Watts at 5.0VDC (16.6mV per Watt) or 300 Watts at 10.0VDC (33.3mV per Watt), depending on the analog voltage range selected.	

R301MKII Specifications

Labels:	Safety:	Per customer requirements. Labels may include Hazardous Voltage, Heavy Object
	Identification:	Seren IPS Inc. part number, serial number, and customer part number (optional), RF output frequency
Battery:	Internal, 3V 255mAh, 23mm Coin Style, Type BR2330 or CR2330 (For retention of user-configurable settings)	
Supplied Accessories:	Power Cord Product Information CD-ROM	
Dimensions inch (mm):	5.25 (133.35) High x 9.50 (241.30) Wide x 18.35 (466.09) Deep. Width without ½-Rack Mounting Brackets: 8.00 (203.2)	
Weight:	22.5 Lbs (10.2Kg)	

L301 Specifications (Discontinued, Part Number Series 960058XXXX)

AC Mains Input Power	<p>Voltage Taps: 98V, 115V, 208V, or 220V Nominal; Single-phase, factory configured.</p> <p>Specify desired AC mains voltage at time of order. Voltage taps are set to the most appropriate setting at the factory. Input power is not field-configurable.</p> <p>Frequency: 47-63 HZ</p> <p>Power required: 750VA Maximum</p> <p>Over-current Protection: Rear Panel Circuit Breaker, 2x 3A 1/4"x1-1/4" time-delay fuses.</p> <p>Current (FLA): 98-125V: 10A Maximum 198-250V: 5A Maximum</p> <p>Short Circuit Current Rating (SCCR) 10KA</p> <p>Inrush Current: 36.2A Nominal</p> <p>Note: For SEMI S2 compliance, the system power distribution panel or system integrator must supply an over-current protection device (fuse or circuit breaker) with a minimum interrupting capacity of 10,000A (10,000AIC).</p>
Power Cord Supplied (Detachable):	<p>98-125V Applications: 14 AWG, 3 Conductor, Type SJT, 2m length, with IEC320-C13 female connector and NEMA 5-15P male plug.</p> <p>198-250V Applications: 14 AWG, 3 Conductor, Type SJT, 2m length, with IEC320-C13 female connector and NEMA L6-15P male plug.</p>
Output:	<p>Power: High Range: 0 to 300 Watts into 50 Ohms Low Range: 0 to 30 Watts into 50 Ohms</p> <p>Maximum Reflected Power: 50 Watts</p> <p>Frequency: 350KHz to 460KHz, variable, 1 KHz steps, frequency synthesized. Other frequency ranges available; consult the factory or local Seren IPS sales representative.</p> <p>Leveling: Forward Power, Load (Net) Power, External Feedback (RF or DC Probe)</p> <p>Power Stability: 0.5% Long Term</p>

L301 Specifications (Discontinued, Part Number Series 960058XXXX)

Output Impedance:		50 Ohms, +/-5 Ohms Nominal
Metering Accuracy: (Forward Power)		+/-3% of Reading, +/- 1 Watt
Temperature Coefficient:		0.25% per °C
Forward Power Regulation:		+/- 1% into 50 Ohms
Load Tolerance:		No oscillation or failure into a mismatch condition.
Protection:		Forward power limits on current, transistor power dissipation, and excessive reflected power. Unit is short-circuit and open-circuit protected. Unit is thermally protected.
Spurious Radiation:		Designed to meet or exceed FCC requirements.
Harmonics:		Equal to or less than -40dBc at maximum output frequency
Noise, Hum, and Ripple:		-50dBc
Pulsing:		20Hz to 10KHz, 1-Hz Steps; 0 to 100% duty cycle; 50 micro-second minimum pulse
Environment:	Operating:	Ambient Temperature: +5°C to +40°C Relative Humidity: 10% to 90% non-condensing, non-icing Atmospheric Pressure: 683 mBar minimum (approx 3000m above sea level) Pollution Degree: 2 or cleaner.
	Storage:	Ambient Temperature: -25°C to +55°C Relative Humidity: 5% to 95%, non-condensing Atmospheric Pressure: 585 mBar minimum (approx 4000m above sea level)

L301 Specifications (Discontinued, Part Number Series 960058XXXX)

Transportation:	Ambient Temperature: -25°C to +70°C Relative Humidity: 95% Maximum absolute humidity when unit temperature directly decreases from +70°C to +15°C Atmospheric Pressure: 480 mBar minimum (approx 5000m above sea level)
Cooling:	Forced Air, 110 CFM (51.91 L/Sec), intake at sides, exhaust at rear panel. Observe specified panel clearances and mounting instructions.
Interface Connections:	Analog Interface: 25 pin Female D-Sub Connector Serial Interface: 9 pin Female D-Sub Connector DCP (Probe) Input: (Optional) Female type BNC connector, 0 to -10VDC CEX Input: Female type BNC connector, 3 to 8V Peak-to-Peak sine wave, 50 Ohms nominal Impedance at specified operating frequency. CEX Output: Female type BNC connector, 5 to 8V Peak-to-Peak into 50 Ohms at specified operating frequency.
Power Monitor Scaling:	Forward Power Monitor Monitor output is linearly proportional to 0 to 300 Watts of forward power. Output scaling is 5.0VDC at 300 Watts (16.6mV/Watt) or 10.0VDC at 300 Watts (33.3mV/Watt), depending on the analog voltage range selected. (Default scaling) Reflected Power Monitor Monitor output is linearly proportional to 0 to 100 Watts of reflected power. Output scaling is 5.0VDC at 100 Watts (50mV/Watt) or 10.0VDC at 100 Watts (100mV/Watt), depending on the analog voltage range selected. (Default scaling)

L301 Specifications (Discontinued, Part Number Series 960058XXXX)

Analog Setpoint Sensitivity: In Power Control mode, analog setpoint sensitivity is 300 Watts at 5.0VDC (16.6mV per Watt) or 300 Watts at 10.0VDC (33.3mV per Watt), depending on the analog voltage range selected.

Labels: Safety: Per customer requirements. Labels may include Hazardous Voltage, Heavy Object

Identification: Seren IPS Inc. part number, serial number, and customer part number (optional), RF output frequency

Supplied Accessories: Power Cord
Product Information CD-ROM

Dimensions inch (mm): 5.25 (133.35) High x 9.50 (241.30) Wide x 18.35 (466.09) Deep.
Width without 1/2-Rack Mounting Brackets: 8.00 (203.2)

Weight: 43 Lbs (19.5Kg)

L301MKII Specifications

Output Impedance:		50 Ohms, +/-5 Ohms Nominal
Metering Accuracy: (Forward Power)		+/-2% of Reading, +/- 1 Watt
Temperature Coefficient:		0.25% per °C
Forward Power Regulation:		+/- 1% into 50 Ohms
Load Tolerance:		No oscillation or failure into a mismatch condition.
Protection:		Forward power limits on current, transistor power dissipation, and excessive reflected power. Unit is short-circuit and open-circuit protected. Unit is thermally protected.
Spurious Radiation:		Designed to meet or exceed FCC requirements.
Harmonics:		Equal to or less than -40dBc at maximum output frequency
Noise, Hum, and Ripple:		-50dBc
Pulsing:		20Hz to 10KHz, 1-Hz Steps; 0 to 100% duty cycle; 50 micro-second minimum pulse
Environment:	Operating:	Ambient Temperature: +5°C to +40°C Relative Humidity: 10% to 90% non-condensing, non-icing Atmospheric Pressure: 683 mBar minimum (approx 3000m above sea level) Pollution Degree: 2 or cleaner.
	Storage:	Ambient Temperature: -25°C to +55°C Relative Humidity: 5% to 95%, non-condensing Atmospheric Pressure: 585 mBar minimum (approx 4000m above sea level)

L301MKII Specifications

Transportation:	<p>Ambient Temperature: -25°C to +70°C</p> <p>Relative Humidity: 95% Maximum absolute humidity when unit temperature directly decreases from +70°C to +15°C</p> <p>Atmospheric Pressure: 480 mBar minimum (approx 5000m above sea level)</p>
Cooling:	<p>Forced Air, 123 CFM (58.05 L/Sec), intake at sides, exhaust at rear panel. Observe specified panel clearances and mounting instructions.</p>
Interface Connections:	<p>Analog Interface: 25 pin Female D-Sub Connector</p> <p>Serial Interface: 9 pin Female D-Sub Connector</p> <p>DCP (Probe) Input: (Optional) Female type BNC connector, 0 to -10VDC</p> <p>CEX Input: Female type BNC connector, 3 to 8V Peak-to-Peak sine wave, 50 Ohms Nominal Impedance at specified operating frequency.</p> <p>CEX Output: Female type BNC connector, 5 to 8V Peak-to-Peak into 50 Ohms at specified operating frequency.</p>
Power Monitor Scaling:	<p>Forward Power Monitor Monitor output is linearly proportional to 0 to 300 Watts of forward power.</p> <p>Output scaling is 5.0VDC at 300 Watts (16.6mV/Watt) or 10.0VDC at 300 Watts (33.3mV/Watt), depending on the analog voltage range selected. (Default scaling)</p> <p>Reflected Power Monitor Monitor output is linearly proportional to 0 to 100 Watts of reflected power.</p> <p>Output scaling is 5.0VDC at 100 Watts (50mV/Watt) or 10.0VDC at 100 Watts (100mV/Watt), depending on the analog voltage range selected. (Default scaling)</p>
Analog Setpoint Sensitivity:	<p>In Power Control mode, analog setpoint sensitivity is 300 Watts at 5.0VDC (16.6mV per Watt) or 300 Watts at 10.0VDC (33.3mV per Watt), depending on the analog voltage range selected.</p>

L301MKII Specifications

Labels:	Safety:	Per customer requirements. Labels may include Hazardous Voltage, Heavy Object
	Identification:	Seren IPS Inc. part number, serial number, and customer part number (optional), RF output frequency
Battery:	Internal, 3V 255mAh, 23mm Coin Style, Type BR2330 or CR2330 (For retention of user-configurable settings)	
Supplied Accessories:	Product Information CD-ROM Power Cord	
Dimensions inch (mm):	5.25 (133.35) High x 9.50 (241.30) Wide x 18.35 (466.09) Deep. Width without ½-Rack Mounting Brackets: 8.00 (203.2)	
Weight:	22.5 Lbs (10.2Kg)	

R601 Specifications

AC Mains Input Power	<p>Nominal Rated Voltage: 117-240V (universal input), Single Phase. Operating Voltage Range: 105-264V (universal input), Single Phase. There are no transformer voltage taps to configure. AC mains voltage specified at time of order determines supplied power cord</p> <p>Frequency: 47-63 HZ Current (FLA): 15A Maximum. Power required: 1360VA Maximum Over-current Protection: Rear Panel Circuit Breaker, 2x 1.5A 1/4"x1-1/4" time-delay fuses. Short Circuit Current Rating (SCCR) 10KA</p> <p>Note: For SEMI S2 compliance, the system power distribution panel or system integrator must supply an over-current protection device (fuse or circuit breaker) with a minimum interrupting capacity of 10,000A (10,000AIC).</p>	
Power Cord Supplied (Detachable):	117-125V Applications:	14 AWG, 3 Conductor, Type SJT, 2m length, with IEC320-C13 female connector to NEMA 5-15P plug. Seren P/N 4500910000
	200-240V Applications:	14 AWG, 3 Conductor, Type SJT, 2m length, with IEC320-C13 female connector to NEMA L6-15P plug. Seren P/N 4500910001
Output:	Power:	High Range: 0 to 600 Watts into 50 Ohms Low Range: 0 to 60 Watts into 50 Ohms
	Maximum Reflected Power:	100 Watts
	Frequency:	13.56 MHz Fixed (standard). Optional frequencies: 27.12MHz Fixed, 40.68MHz Fixed, 12.56-14.56MHz Variable, 1.7-2.1MHz Variable; specify frequency when ordering.
	Leveling:	Forward Power, Load (Net) Power, External Feedback (RF or DC Probe)
	Power Stability:	0.5% Long Term, +/- 1 Watt
	Output Impedance:	50 Ohms, +/-5 Ohms Nominal

R601 Specifications

Metering Accuracy: (Forward Power)	+/- 2% of Reading, +/- 1 Watt
Temperature Coefficient:	0.25% per °C
Forward Power Regulation:	+/- 1% into 50 Ohms
Load Tolerance:	No oscillation or failure into a mismatch condition.
Protection:	Forward power limits on current, transistor power dissipation, and excessive reflected power. Unit is short-circuit and open-circuit protected. Unit is thermally protected.
Spurious Radiation:	Designed to meet or exceed FCC requirements.
Harmonics:	-50dBc
Noise, Hum, and Ripple:	-50dBc
Pulsing:	20Hz to 10KHz, 1-Hz Steps; 0 to 100% duty cycle; 50 micro-second minimum pulse
Environment: Operating:	Ambient Temperature: +5°C to +40°C Relative Humidity: 10% to 90% non-condensing, non-icing Atmospheric Pressure: 683 mBar minimum (approx 3000m above sea level) Pollution Degree: 2 or cleaner.
Storage:	Ambient Temperature: -25°C to +55°C Relative Humidity: 5% to 95%, non-condensing Atmospheric Pressure: 585 mBar minimum (approx 4000m above sea level)

R601 Specifications

Transportation:	<p>Ambient Temperature: -25°C to +70°C</p> <p>Relative Humidity: 95% Maximum absolute humidity when unit temperature directly decreases from +70°C to +15°C</p> <p>Atmospheric Pressure: 480 mBar minimum (approx 5000m above sea level)</p>
Cooling:	<p>Forced Air, 123 CFM (58.05 L/sec), intake at sides, exhaust at rear panel. Observe specified panel clearances and mounting instructions.</p>
Interface Connections:	<p>Analog Interface: 25 pin Female D-Sub Connector</p> <p>Serial Interface: 9 pin Female D-Sub Connector</p>
CEX Input:	<p>Female type BNC connector, 3 to 8V Peak-to-Peak sine wave, 50 Ohms Nominal Impedance at specified operating frequency.</p>
CEX Output:	<p>Female type BNC connector, 5 to 8V Peak-to-Peak into 50 Ohms at specified operating frequency.</p>
Power Monitor Scaling:	<p>Forward Power Monitor Monitor output is linearly proportional to 0 to 600 Watts of forward power.</p> <p>Output scaling is 5.0VDC at 600 Watts (8.33mV/Watt) or 10.0VDC at 600 Watts (16.6mV/Watt), depending on the analog voltage range selected. (Default scaling)</p> <p>Reflected Power Monitor Monitor output is linearly proportional to 0 to 100 Watts of reflected power.</p> <p>Output scaling is 5.0VDC at 100 Watts (50mV/Watt) or 10.0VDC at 100 Watts (100mV/Watt), depending on the analog voltage range selected. (Default scaling)</p>
Analog Setpoint Sensitivity:	<p>In Power Control mode, analog setpoint sensitivity is 600 Watts at 5.0VDC (8.33mV per Watt) or 600 Watts at 10.0VDC (16.6mV per Watt), depending on the analog voltage range selected.</p>

R601 Specifications

Labels:	Safety:	Per customer requirements. Labels may include Hazardous Voltage, Heavy Object
	Identification:	Seren IPS Inc. part number, serial number, and customer part number (optional), RF output frequency
Battery:	Internal, 3V 255mAh, 23mm Coin Style, Type BR2330 or CR2330 (For retention of user-configurable settings)	
Supplied Accessories:	Product Information CD-ROM Power Cord	
Dimensions inch (mm):	7.00 (177.80) High x 9.50 (241.30) Wide x 18.38 (466.85) Deep. Width includes ½-Rack Mounting Brackets. Width without ½-Rack Mounting Brackets: 8.00 (203.2)	
Weight:	37 Lbs (16.8Kg)	

L601 Specifications

AC Mains	Nominal Rated Voltage: 117-240V (universal input), Single Phase.	
Input Power	Operating Voltage Range: 105-264V, Single Phase.	
	There are no transformer voltage taps to configure.	
	AC mains voltage specified at time of order determines supplied power cord	
	Frequency:	47-63 HZ
	Current (FLA):	15A Maximum.
	Power required:	1360VA Maximum
	Over-current Protection:	Rear Panel Circuit Breaker, 2x 1.5A 1/4"x1-1/4" time-delay fuses.
	Short Circuit Current Rating (SCCR)	10KA
	Note: For SEMI S2 compliance, the system power distribution panel or system integrator must supply an over-current protection device (fuse or circuit breaker) with a minimum interrupting capacity of 10,000A (10,000AIC).	
Power Cord Supplied (Detachable):	117-125V Applications:	14 AWG, 3 Conductor, Type SJT, 2m length, with IEC320-C13 female connector to NEMA 5-15P plug. Seren P/N 4500910000
	200-240V Applications:	14 AWG, 3 Conductor, Type SJT, 2m length, with IEC320-C13 female connector to NEMA L6-15P plug. Seren P/N 4500910001
Output:	Power:	High Range: 0 to 600 Watts into 50 Ohms Low Range: 0 to 60 Watts into 50 Ohms
	Maximum Reflected Power:	100 Watts
	Frequency:	350KHz to 460KHz, variable, 1 KHz steps, frequency synthesized. Other frequency ranges available; consult the factory or local Seren IPS sales representative.
	Leveling:	Forward Power, Load (Net) Power, External Feedback (RF or DC Probe)
	Power Stability:	0.5% Long Term, +/- 1 Watt
	Output Impedance:	50 Ohms, +/-5 Ohms Nominal

L601 Specifications

	Metering Accuracy: (Forward Power)	+/- 2% of Reading, +/- 1 Watt
	Temperature Coefficient:	0.25% per °C
	Forward Power Regulation:	+/- 1% into 50 Ohms
	Load Tolerance:	No oscillation or failure into a mismatch condition.
	Protection:	Forward power limits on current, transistor power dissipation, and excessive reflected power. Unit is short-circuit and open-circuit protected. Unit is thermally protected.
	Spurious Radiation:	Designed to meet or exceed FCC requirements.
	Harmonics:	Equal to or less than -40dBc at maximum output frequency
	Noise, Hum, and Ripple:	-50dBc
	Pulsing:	20Hz to 10KHz, 1-Hz Steps; 0 to 100% duty cycle; 50 micro-second minimum pulse
Environment:	Operating:	Ambient Temperature: +5°C to +40°C Relative Humidity: 10% to 90% non-condensing, non-icing Atmospheric Pressure: 683 mBar minimum (approx 3000m above sea level) Pollution Degree: 2 or cleaner.
	Storage:	Ambient Temperature: -25°C to +55°C Relative Humidity: 5% to 95%, non-condensing Atmospheric Pressure: 585 mBar minimum (approx 4000m above sea level)

L601 Specifications

Transportation:	Ambient Temperature: -25°C to +70°C Relative Humidity: 95% Maximum absolute humidity when unit temperature directly decreases from +70°C to +15°C Atmospheric Pressure: 480 mBar minimum (approx 5000m above sea level)
Cooling:	Forced Air, 123 CFM (58.05 L/sec), intake at sides, exhaust at rear panel. Observe specified panel clearances and mounting instructions.
Interface Connections:	Analog Interface: 25 pin Female D-Sub Connector Serial Interface: 9 pin Female D-Sub Connector CEX Input: Female type BNC connector, 3 to 8V Peak-to-Peak sine wave, 50 Ohms Nominal Impedance at specified operating frequency. CEX Output: Female type BNC connector, 5 to 8V Peak-to-Peak into 50 Ohms at specified operating frequency.
Power Monitor Scaling:	Forward Power Monitor Monitor output is linearly proportional to 0 to 600 Watts of forward power. Output scaling is 5.0VDC at 600 Watts (8.33mV/Watt) or 10.0VDC at 600 Watts (16.6mV/Watt), depending on the analog voltage range selected. (Default scaling) Reflected Power Monitor Monitor output is linearly proportional to 0 to 100 Watts of reflected power. Output scaling is 5.0VDC at 100 Watts (50mV/Watt) or 10.0VDC at 100 Watts (100mV/Watt), depending on the analog voltage range selected. (Default scaling)
Analog Setpoint Sensitivity:	In Power Control mode, analog setpoint sensitivity is 600 Watts at 5.0VDC (8.33mV per Watt) or 600 Watts at 10.0VDC (16.6mV per Watt), depending on the analog voltage range selected.

L601 Specifications

Labels:	Safety:	Per customer requirements. Labels may include Hazardous Voltage, Heavy Object
	Identification:	Seren IPS Inc. part number, serial number, and customer part number (optional), RF output frequency
Battery:		Internal, 3V 255mAh, 23mm Coin Style, Type BR2330 or CR2330 (For retention of user-configurable settings)
Supplied Accessories:		Power Cord Product Information CD-ROM
Dimensions inch (mm):		7.00 (177.80) High x 9.50 (241.30) Wide x 18.38 (466.85) Deep. Width includes ½-Rack Mounting Brackets. Width without ½-Rack Mounting Brackets: 8.00 (203.2)
Weight:		37 Lbs (16.8Kg)

R1001 Specifications

AC Mains	Nominal Rated Voltage: 208-240V, Single Phase.	
Input Power	Operating Voltage Range: 190-264V, Single Phase	
	There are no transformer voltage taps to configure.	
	Frequency:	47-63 HZ
	Current (FLA):	15A Maximum.
	Power required:	1650VA Maximum
	Overcurrent Protection:	Rear Panel Circuit Breaker, 2x 1.5A ¼"x1-1/4" time-delay fuses.
	Short Circuit Current Rating (SCCR)	10KA
	Note: For SEMI S2 compliance, the system power distribution panel or system integrator must supply an over-current protection device (fuse or circuit breaker) with a minimum interrupting capacity of 10,000A (10,000AIC).	
Power Cord Supplied:	Detachable, 14 AWG, 3 Conductor, Type SJT, 2m length, with IEC320-C13 female connector to NEMA L6-15P plug. Seren P/N 4500910001	
Output:	Power:	0 to 1000 Watts into 50 Ohms
	Maximum Reflected Power:	100 Watts
	Frequency:	13.56 MHz Fixed (standard). Optional frequencies: 27.12MHz Fixed, 40.68MHz Fixed, 12.56-14.56MHz Variable, 1.7-2.1MHz Variable; specify frequency when ordering.
	Leveling:	Forward Power, Load (Net) Power, External Feedback (RF or DC Probe)
	Power Stability:	0.5% Long Term, +/- 1 Watt
	Output Impedance:	50 Ohms, +/-5 Ohms Nominal
	Metering Accuracy: (Forward Power)	+/- 2% of Reading, +/- 1 Watt
	Temperature Coefficient:	0.25% per °C
	Forward Power Regulation:	+/- 1% into 50 Ohms

R1001 Specifications

Load Tolerance:	No oscillation or failure into a mismatch condition.
Protection:	Forward power limits on current, transistor power dissipation, and excessive reflected power. Unit is short-circuit and open-circuit protected. Unit is thermally protected.
Spurious Radiation:	Designed to meet or exceed FCC requirements.
Harmonics:	-50dBc
Noise, Hum, and Ripple:	-50dBc
Pulsing:	20Hz to 10KHz, 1-Hz Steps; 0 to 100% duty cycle; 50 micro-second minimum pulse
Environment:	<p>Operating: Ambient Temperature: +5°C to +40°C Relative Humidity: 10% to 90% non-condensing, non-icing Atmospheric Pressure: 683 mBar minimum (approx 3000m above sea level) Pollution Degree: 2 or cleaner.</p> <p>Storage: Ambient Temperature: -25°C to +55°C Relative Humidity: 5% to 95%, non-condensing Atmospheric Pressure: 585 mBar minimum (approx 4000m above sea level)</p> <p>Transportation: Ambient Temperature: -25°C to +70°C Relative Humidity: 95% Maximum absolute humidity when unit temperature directly decreases from +70°C to +15°C Atmospheric Pressure: 480 mBar minimum (approx 5000m above sea level)</p>
Cooling:	Forced Air, 123 CFM (58.05 L/sec), intake at sides, exhaust at rear panel. Observe specified panel clearances and mounting instructions.

R1001 Specifications

Interface Connections:	Analog Interface:	25 pin Female D-Sub Connector
	Serial Interface:	9 pin Female D-Sub Connector
	CEX Input:	Female type BNC connector, 3 to 8V Peak-to-Peak sine wave, 50 Ohms Nominal Impedance at specified operating frequency.
	CEX Output:	Female type BNC connector, 5 to 8V Peak-to-Peak into 50 Ohms at specified operating frequency.
Power Monitor Scaling:	Forward Power Monitor	Monitor output is linearly proportional to 0 to 1000 Watts of forward power. Output scaling is 5.0VDC at 1000 Watts (5.0mV/Watt) or 10.0VDC at 1000 Watts (10mV/Watt), depending on the analog voltage range selected. (Default scaling)
	Reflected Power Monitor	Monitor output is linearly proportional to 0 to 100 Watts of reflected power. Output scaling is 5.0VDC at 100 Watts (50mV/Watt) or 10.0VDC at 100 Watts (100mV/Watt), depending on the analog voltage range selected. (Default scaling)
Analog Setpoint Sensitivity:	In Power Control mode, analog setpoint sensitivity is 1000 Watts at 5.0VDC (5.0mV per Watt) or 1000 Watts at 10.0VDC (10mV per Watt), depending on the analog voltage range selected.	
Labels:	Safety:	Per customer requirements. Labels may include Hazardous Voltage, Heavy Object
	Identification:	Seren IPS Inc. part number, serial number, and customer part number (optional), RF output frequency
Battery:	Internal, 3V 255mAh, 23mm Coin Style, Type BR2330 or CR2330 (For retention of user-configurable settings)	
Supplied Accessories:	Product Information CD-ROM Power Cord	

R1001 Specifications

Dimensions 7.00 (177.80) High x 9.50 (241.30) Wide x 18.38 (466.85) Deep. Width
inch (mm): includes ½-Rack Mounting Brackets.
Width without ½-Rack Mounting Brackets: 8.00 (203.2)

Weight: 37 Lbs (16.8Kg)

R1001W Specifications

AC Mains	Nominal Rated Voltage: 208-240V, Single Phase.	
Input Power	Operating Voltage Range: 190-264V, Single Phase	
	There are no transformer voltage taps to configure.	
	Frequency:	47-63 HZ
	Current (FLA):	15A Maximum.
	Power required:	1650VA Maximum
	Over-current Protection:	Rear Panel Circuit Breaker, 2x 1.5A ¼"x1-1/4" time-delay fuses.
	Short Circuit Current Rating (SCCR)	10KA
	Note: For SEMI S2 compliance, the system power distribution panel or system integrator must supply an over-current protection device (fuse or circuit breaker) with a minimum interrupting capacity of 10,000A (10,000AIC).	
Power Cord Supplied:	Detachable, 14 AWG, 3 Conductor, Type SJT, 2m length, with IEC320-C13 female connector to NEMA L6-15P plug. Seren P/N 4500910001	
Output:	Power:	0 to 1200 Watts into 50 Ohms
	Maximum Reflected Power:	150 Watts
	Frequency:	13.56 MHz Fixed (standard). Optional frequencies: 27.12MHz Fixed, 40.68MHz Fixed, 12.56-14.56MHz Variable, 1.7-2.1MHz Variable; specify frequency when ordering.
	Leveling:	Forward Power, Load (Net) Power, External Feedback (RF or DC Probe)
	Power Stability:	0.5% Long Term, +/- 1 Watt
	Output Impedance:	50 Ohms, +/-5 Ohms Nominal
	Metering Accuracy: (Forward Power)	+/- 2% of Reading, +/- 1 Watt
	Temperature Coefficient:	0.25% per °C
	Forward Power Regulation:	+/- 1% into 50 Ohms

R1001W Specifications

Load Tolerance:	No oscillation or failure into a mismatch condition.
Protection:	Forward power limits on current, transistor power dissipation, and excessive reflected power. Unit is short-circuit and open-circuit protected. Unit is thermally protected.
Spurious Radiation:	Designed to meet or exceed FCC requirements.
Harmonics:	-50dBc
Noise, Hum, and Ripple:	-50dBc
Pulsing:	20Hz to 10KHz, 1-Hz Steps; 0 to 100% duty cycle; 50 micro-second minimum pulse
Environment:	<p>Operating: Ambient Temperature: +5°C to +40°C Relative Humidity: 10% to 90% non-condensing, non-icing Atmospheric Pressure: 683 mBar minimum (approx 3000m above sea level) Pollution Degree: 2 or cleaner.</p> <p>Storage: Ambient Temperature: -25°C to +55°C Relative Humidity: 5% to 95%, non-condensing Atmospheric Pressure: 585 mBar minimum (approx 4000m above sea level)</p> <p>Transportation: Ambient Temperature: -25°C to +70°C Relative Humidity: 95% Maximum absolute humidity when unit temperature directly decreases from +70°C to +15°C Atmospheric Pressure: 480 mBar minimum (approx 5000m above sea level)</p>

R1001W Specifications

Cooling:	Ventilation:	Forced Air, 60 CFM (28.31 L/Sec), intake at sides, exhaust at rear panel. Observe specified panel clearances and mounting instructions
	Coolant Water:	Flow: 1.2 gallon/minute (4.54 L/min) minimum. Inlet Temperature: +15°C minimum to +40°C maximum temperature, +22°C to +28°C recommended. Pressure: 70 PSI (482.63 kPa) maximum
	Coolant Water Purity:	pH: Between 7 and 9 Total Chlorine: <20ppm Total Nitrate: <10ppm Total Sulfate: <100ppm Total Dissolved Solids: <250ppm Total Hardness expressed as Calcium Carbonate equivalent: <250ppm Specific Resistivity: >2500 Ohms/cm @ +25°C
	Coolant Water Fittings:	Type 3/8" N.P.T. Female threaded pipe
	Coolant Water Supply Line Inside Diameter:	3/8" [9.52mm] Inside Diameter (I.D.) or larger.
	Waste Heat into Coolant Water	750 Watts maximum. Note: The waste heat does not peak at 1200 Watts of output power - the waste heat peaks at 50% to 80% of full power or under certain reflected power conditions.
Interlocks:	External:	External interlock provided for disabling RF output power
	Valve (optional):	Prevents/disables RF Power output if external water valve is missing or un plugged. (Standard units ignore this interlock – consult factory if valve interlock is required)

R1001W Specifications

Interface Connections:	Analog Interface:	25 pin Female D-Sub Connector
	Serial Interface:	9 pin Female D-Sub Connector
	CEX Input:	Female type BNC connector, 3 to 8V Peak-to-Peak sine wave, 50 Ohms Nominal Impedance at specified operating frequency.
	CEX Output:	Female type BNC connector, 5 to 8V Peak-to-Peak into 50 Ohms at specified operating frequency.
	VALVE	4-Pin Male Disk-Drive Connector
Power Monitor Scaling:	Forward Power Monitor	Monitor output is linearly proportional to 0 to 1200 Watts of forward power. Output scaling is 5.0VDC at 1200 Watts (4.16mV/Watt) or 10.0VDC at 1200 Watts (8.33mV/Watt), depending on the analog voltage range selected. (Default scaling)
	Reflected Power Monitor	Monitor output is linearly proportional to 0 to 100 Watts of reflected power. Output scaling is 5.0VDC at 150 Watts (33.3mV/Watt) or 10.0VDC at 150 Watts (66.6mV/Watt), depending on the analog voltage range selected. (Default scaling)
Analog Setpoint Sensitivity:	In Power Control mode, analog setpoint sensitivity is 1200 Watts at 5.0VDC (4.16mV per Watt) or 1200 Watts at 10.0VDC (8.33mV per Watt), depending on the analog voltage range selected.	
Labels:	Safety:	Per customer requirements. Labels may include Hazardous Voltage, Heavy Object
	Identification:	Seren IPS Inc. part number, serial number, and customer part number (optional), RF output frequency
Battery:	Internal, 3V 255mAh, 23mm Coin Style, Type BR2330 or CR2330 (For retention of user-configurable settings)	

R1001W Specifications

Supplied	Solenoid Water Valve
Accessories:	Power Cord Product Information CD-ROM
Dimensions inch (mm):	7.00 (177.80) High x 9.50 (241.30) Wide x 18.38 (466.85) Deep. Width includes ½-Rack Mounting Brackets. Width without ½-Rack Mounting Brackets: 8.00 (203.2)
Weight:	37 Lbs (16.8Kg)

L1001 Specifications

AC Mains	Nominal Rated Voltage: 208-240V, Single Phase.	
Input Power	Operating Voltage Range: 190-264V, Single Phase	
	There are no transformer voltage taps to configure.	
	Frequency:	47-63 HZ
	Current (FLA):	15A Maximum.
	Power Required:	1650VA Maximum
	Over-current Protection:	Rear Panel Circuit Breaker, 2x 1.5A 1/4"x1-1/4" time-delay fuses.
	Short Circuit Current Rating (SCCR)	10KA
	Note: For SEMI S2 compliance, the system power distribution panel or system integrator must supply an over-current protection device (fuse or circuit breaker) with a minimum interrupting capacity of 10,000A (10,000AIC).	
Power Cord Supplied:	Detachable, 14/3 Type SJT, 2m length, with IEC320-C13 female connector to NEMA L6-15P plug. Seren P/N 4500910001	
Output:	Power:	0 to 1000 Watts into 50 Ohms
	Maximum Reflected Power:	100 Watts
	Frequency:	350KHz to 460KHz, variable, 1 KHz steps, frequency synthesized. Other frequency ranges available; consult the factory or local Seren IPS sales representative.
	Leveling:	Forward Power, Load (Net) Power, External Feedback (RF or DC Probe)
	Power Stability:	0.5% Long Term, +/- 1 Watt
	Output Impedance:	50 Ohms, +/-5 Ohms Nominal
	Metering Accuracy (Forward Power)	+/- 2% of Reading, +/- 1 Watt
	Temperature Coefficient:	0.25% per °C
	Forward Power Regulation:	+/- 1% into 50 Ohms

L1001 Specifications

Load Tolerance:	No oscillation or failure into a mismatch condition.
Protection:	Forward power limits on current, transistor power dissipation, and excessive reflected power. Unit is short-circuit and open-circuit protected. Unit is thermally protected.
Spurious Radiation:	Designed to meet or exceed FCC requirements.
Harmonics:	Equal to or less than -40dBc at maximum output frequency
Noise, Hum, and Ripple:	-50dBc
Pulsing:	20Hz to 10KHz, 1-Hz Steps; 0 to 100% duty cycle; 50 micro-second minimum pulse
Environment: Operating:	Ambient Temperature: +5°C to +40°C Relative Humidity: 10% to 90% non-condensing, non-icing Atmospheric Pressure: 683 mBar minimum (approx 3000m above sea level) Pollution Degree: 2 or cleaner.
Storage:	Ambient Temperature: -25°C to +55°C Relative Humidity: 5% to 95%, non-condensing Atmospheric Pressure: 585 mBar minimum (approx 4000m above sea level)
Transportation:	Ambient Temperature: -25°C to +70°C Relative Humidity: 95% Maximum absolute humidity when unit temperature directly decreases from +70°C to +15°C Atmospheric Pressure: 480 mBar minimum (approx 5000m above sea level)
Cooling:	Forced Air, 123 CFM (58.05 L/sec), intake at sides, exhaust at rear panel. Observe specified panel clearances and mounting instructions.

L1001 Specifications

Interface Connections:	Analog Interface:	25 pin Female D-Sub Connector
	Serial Interface:	9 pin Female D-Sub Connector
	CEX Input:	Female type BNC connector, 3 to 8V Peak-to-Peak sine wave, 50 Ohms Nominal Impedance at specified operating frequency.
	CEX Output:	Female type BNC connector, 5 to 8V Peak-to-Peak into 50 Ohms at specified operating frequency.
Power Monitor Scaling:	Forward Power Monitor	Monitor output is linearly proportional to 0 to 1000 Watts of forward power. Output scaling is 5.0VDC at 1000 Watts (5.0mV/Watt) or 10.0VDC at 1000 Watts (10mV/Watt), depending on the analog voltage range selected. (Default scaling)
	Reflected Power Monitor	Monitor output is linearly proportional to 0 to 100 Watts of reflected power. Output scaling is 5.0VDC at 100 Watts (50mV/Watt) or 10.0VDC at 100 Watts (100mV/Watt), depending on the analog voltage range selected. (Default scaling)
Analog Setpoint Sensitivity:	In Power Control mode, analog setpoint sensitivity is 1000 Watts at 5.0VDC (5.0mV per Watt) or 1000 Watts at 10.0VDC (10mV per Watt), depending on the analog voltage range selected.	
Labels:	Safety:	Per customer requirements. Labels may include Hazardous Voltage, Heavy Object
	Identification:	Seren IPS Inc. part number, serial number, and customer part number (optional), RF output frequency
Battery:	Internal, 3V 255mAh, 23mm Coin Style, Type BR2330 or CR2330 (For retention of user-configurable settings)	
Supplied Accessories:	Power Cord Product Information CD-ROM	

L1001 Specifications

Dimensions 7.00 (177.80) High x 9.50 (241.30) Wide x 18.38 (466.85) Deep. Width
inch (mm): includes ½-Rack Mounting Brackets.
Width without ½-Rack Mounting Brackets: 8.00 (203.2)

Weight: 37 Lbs (16.8Kg)

L1001W Specifications

AC Mains	Nominal Rated Voltage: 208-240V, Single Phase.	
Input Power	Operating Voltage Range: 190-264V, Single Phase	
	There are no transformer voltage taps to configure.	
	Frequency:	47-63 HZ
	Current (FLA):	15A Maximum.
	Power required:	1650VA Maximum
	Over-current Protection:	Rear Panel Circuit Breaker, 2x 1.5A ¼"x1-1/4" time-delay fuses.
	Short Circuit Current Rating (SCCR)	10KA
	Note: For SEMI S2 compliance, the system power distribution panel or system integrator must supply an over-current protection device (fuse or circuit breaker) with a minimum interrupting capacity of 10,000A (10,000AIC).	
Power Cord Supplied:	Detachable, 14 AWG, 3 Conductor, Type SJT, 2m length, with IEC320-C13 female connector to NEMA L6-15P plug. Seren P/N 4500910001	
Output:	Power:	0 to 1200 Watts into 50 Ohms
	Maximum Reflected Power:	150 Watts
	Frequency:	350KHz to 460KHz, variable, 1 KHz steps, frequency synthesized. Other frequency ranges available; consult the factory or local Seren IPS sales representative.
	Leveling:	Forward Power, Load (Net) Power, External Feedback (RF or DC Probe)
	Power Stability:	0.5% Long Term, +/- 1 Watt
	Output Impedance:	50 Ohms, +/-5 Ohms Nominal
	Metering Accuracy (Forward Power)	+/- 2% of Reading, +/- 1 Watt
	Temperature Coefficient:	0.25% per °C
	Forward Power Regulation:	+/- 1% into 50 Ohms

L1001W Specifications

Load Tolerance:	No oscillation or failure into a mismatch condition.
Protection:	Forward power limits on current, transistor power dissipation, and excessive reflected power. Unit is short-circuit and open-circuit protected. Unit is thermally protected.
Spurious Radiation:	Designed to meet or exceed FCC requirements.
Harmonics:	-50dBc
Noise, Hum, and Ripple:	-50dBc
Pulsing:	20Hz to 10KHz, 1-Hz Steps; 0 to 100% duty cycle; 50 micro-second minimum pulse
Environment: Operating:	Ambient Temperature: +5°C to +40°C Relative Humidity: 10% to 90% non-condensing, non-icing Atmospheric Pressure: 683 mBar minimum (approx 3000m above sea level) Pollution Degree: 2 or cleaner.
Storage:	Ambient Temperature: -25°C to +55°C Relative Humidity: 5% to 95%, non-condensing Atmospheric Pressure: 585 mBar minimum (approx 4000m above sea level)
Transportation:	Ambient Temperature: -25°C to +70°C Relative Humidity: 95% Maximum absolute humidity when unit temperature directly decreases from +70°C to +15°C Atmospheric Pressure: 480 mBar minimum (approx 5000m above sea level)

L1001W Specifications

Cooling:	Ventilation:	Forced Air, 60 CFM (28.31 L/Sec), intake at sides, exhaust at rear panel. Observe specified panel clearances and mounting instructions
	Coolant Water:	Flow: 1.2 gallon/minute (4.54 L/min) minimum. Inlet Temperature: +15°C minimum to +40°C maximum temperature, +22°C to +28°C recommended. Pressure: 70 PSI (482.63 kPa) maximum
	Coolant Water Purity:	pH: Between 7 and 9 Total Chlorine: <20ppm Total Nitrate: <10ppm Total Sulfate: <100ppm Total Dissolved Solids: <250ppm Total Hardness expressed as Calcium Carbonate equivalent: <250ppm Specific Resistivity: >2500 Ohms/cm @ +25°C
	Coolant Water Fittings:	Type 3/8" N.P.T. Female threaded pipe
	Coolant Water Supply Line Inside Diameter:	3/8" [9.52mm] Inside Diameter (I.D.) or larger.
	Waste Heat into Coolant Water	750 Watts maximum. Note: The waste heat does not peak at 1200 Watts of output power - the waste heat peaks at 50% to 80% of full power or under certain reflected power conditions.
Interlocks:	External:	External interlock provided for disabling RF output power
	Valve (optional):	Prevents/disables RF Power output if external water valve is missing or un plugged. (Standard units ignore this interlock – consult factory if valve interlock is required)

L1001W Specifications

Interface Connections:	Analog Interface:	25 pin Female D-Sub Connector
	Serial Interface:	9 pin Female D-Sub Connector
	CEX Input:	Female type BNC connector, 3 to 8V Peak-to-Peak sine wave, 50 Ohms Nominal Impedance at specified operating frequency.
	CEX Output:	Female type BNC connector, 5 to 8V Peak-to-Peak into 50 Ohms at specified operating frequency.
	VALVE	4-Pin Male Disk-Drive Connector
Power Monitor Scaling:	Forward Power Monitor	Monitor output is linearly proportional to 0 to 1200 Watts of forward power. Output scaling is 5.0VDC at 1200 Watts (4.16mV/Watt) or 10.0VDC at 1200 Watts (8.33mV/Watt), depending on the analog voltage range selected. (Default scaling)
	Reflected Power Monitor	Monitor output is linearly proportional to 0 to 100 Watts of reflected power. Output scaling is 5.0VDC at 150 Watts (33.3mV/Watt) or 10.0VDC at 150 Watts (66.6mV/Watt), depending on the analog voltage range selected. (Default scaling)
Analog Setpoint Sensitivity:	In Power Control mode, analog setpoint sensitivity is 1200 Watts at 5.0VDC (4.16mV per Watt) or 1200 Watts at 10.0VDC (8.33mV per Watt), depending on the analog voltage range selected.	
Labels:	Safety:	Per customer requirements. Labels may include Hazardous Voltage, Heavy Object
	Identification:	Seren IPS Inc. part number, serial number, and customer part number (optional), RF output frequency
Battery:	Internal, 3V 255mAh, 23mm Coin Style, Type BR2330 or CR2330 (For retention of user-configurable settings)	

L1001W Specifications

Supplied	Solenoid Water Valve
Accessories:	Power Cord Product Information CD-ROM
Dimensions inch (mm):	7.00 (177.80) High x 9.50 (241.30) Wide x 18.38 (466.85) Deep. Width includes ½-Rack Mounting Brackets. Width without ½-Rack Mounting Brackets: 8.00 (203.2)
Weight:	37 Lbs (16.8Kg)

R2001 Specifications

AC Mains Input Power	Available Options, specify at time of order:	
	<ol style="list-style-type: none"> 1. Nominal Voltage Rating: 208-240V, Single Phase Operating Voltage Range: 190-264V, Single Phase 2. Nominal Voltage Rating: 208-240V, Three-Phase 4-Wire Delta Operating Voltage Range: 190-264V, Three Phase 4-Wire Delta 3. Nominal Voltage Rating: 380-415V, Three Phase 5-Wire Wye Operating Voltage Range: 342-457V, Three Phase 5-Wire Wye 	
	There are no transformer voltage taps to configure. Input power is not field-configurable.	
	Frequency:	47-63 HZ
	Current (FLA):	208-240V Single Phase: 20A Maximum 208-240V Three Phase 4-Wire Delta: 20A Per Phase Maximum 380-415V, Three Phase 5-Wire Wye: 10A Per Phase Maximum
	Power Required:	3375VA Maximum
	Overcurrent Protection:	Rear Panel Circuit Breaker, 2x 1.5A ¼"x1-1/4" time-delay fuses.
	Short Circuit Current Rating (SCCR)	10KA
	Note: For SEMI S2 compliance, the system power distribution panel or system integrator must supply an over-current protection device (fuse or circuit breaker) with a minimum interrupting capacity of 10,000A (10,000AIC).	
Power Cord and Power Plug:	208-240V Single Phase:	Cord: Captive, 12 AWG, 3 Conductor, Type SOW, 6 foot (1.82m) length Plug: NEMA Type L6-20P locking connector
	208-240V Three Phase 4-Wire Delta:	Cord: Captive, 12 AWG, 4 Conductor, Type SOW, 6 foot (1.82m) length Plug: NEMA type L15-20P locking connector
	380-415V Three Phase 5-Wire Wye:	Cord: Captive, 12 AWG, 5 Conductor, Type SOOW, 10 foot (3.05m) length Plug: None Supplied. The installer is responsible for connecting and/or terminating the power cord in accordance with applicable national and local codes.

R2001 Specifications

Output:	Power:	0 to 2000 Watts into 50 Ohms
	Maximum Reflected Power:	200 Watts
	Frequency:	13.56MHz Fixed (standard), Optional Frequencies (specify at time of order): 1.7-2.1MHz Variable (1 KHz Steps) Frequency Synthesized, 27.12MHz Fixed, 40.68MHz Fixed
	Leveling:	Forward Power, Load (Net) Power, External Feedback (RF or DC Probe)
	RF Output Connector:	Type N, HN, or 7/16 DIN female. Customer Specified
	Power Stability:	0.5% Long Term, +/- 1 Watt
	Output Impedance:	50 Ohms, +/-5 Ohms Nominal
	Metering Accuracy: (Forward Power)	+/- 2% of Reading, +/- 1 Watt
	Temperature Coefficient:	0.25% per °C
	Forward Power Regulation:	+/- 1% into 50 Ohms
	Load Tolerance:	No oscillation or failure into a mismatch condition.
	Protection:	Forward power limits on current, transistor power dissipation, and excessive reflected power. Unit is short-circuit and open-circuit protected. Unit is thermally protected.
	Spurious Radiation:	Designed to meet or exceed FCC requirements.
	Harmonics:	-50dBc
	Noise, Hum, and Ripple:	-50dBc
	Pulsing:	20Hz to 10KHz, 1-Hz Steps; 0 to 100% duty cycle; 50 micro-second minimum pulse

R2001 Specifications

Environment:	Operating:	<p>Ambient Temperature: +5°C to +40°C</p> <p>Relative Humidity: 10% to 90% non-condensing, non-icing</p> <p>Atmospheric Pressure: 683 mBar minimum (approx 3000m above sea level)</p> <p>Pollution Degree: 2 or cleaner.</p>
	Storage:	<p>Ambient Temperature: -25°C to +55°C</p> <p>Relative Humidity: 5% to 95%, non-condensing</p> <p>Atmospheric Pressure: 585 mBar minimum (approx 4000m above sea level)</p>
	Transportation:	<p>Ambient Temperature: -25°C to +70°C</p> <p>Relative Humidity: 95% Maximum absolute humidity when unit temperature directly decreases from +70°C to +15°C</p> <p>Atmospheric Pressure: 480 mBar minimum (approx 5000m above sea level)</p>
Cooling:	Ventilation:	<p>Forced Air, 150 CFM (70.79 L/Sec), intake at sides, exhaust at rear panel. Observe specified panel clearances and mounting instructions</p>
	Coolant Water:	<p>Flow: 2.0 gallon/minute (7.57 L/min) minimum.</p> <p>Inlet Temperature: +15°C minimum to +40°C maximum temperature, +22°C to +28°C recommended.</p> <p>Pressure: 70 PSI (482.63 kPa) maximum</p>
	Coolant Water Purity:	<p>pH: Between 7 and 9</p> <p>Total Chlorine: <20ppm</p> <p>Total Nitrate: <10ppm</p> <p>Total Sulfate: <100ppm</p> <p>Total Dissolved Solids: <250ppm</p> <p>Total Hardness expressed as Calcium Carbonate equivalent: <250ppm</p> <p>Specific Resistivity: >2500 Ohms/cm @ +25°C</p>
	Coolant Water Fittings:	<p>Type 3/8" N.P.T. Female threaded pipe</p>

R2001 Specifications

Coolant Water Supply Line Inside Diameter:	3/8" [9.52mm] Inside Diameter (I.D.) or larger.
Waste Heat into Coolant Water	1600 Watts (91 BTU/minute) maximum. Note: The waste heat does not peak at 2000 Watts of output power - the waste heat peaks at 50% to 80% of full power or under certain reflected power conditions.
Interlocks:	<p>External: External interlock provided for disabling RF output power</p> <p>Valve (optional): Prevents/disables RF Power output if external water valve is missing or un plugged. (standard units ignore this interlock – consult factory if valve interlock is required)</p>
Interface Connections:	<p>Analog Interface: 25 pin Female D-Sub Connector</p> <p>Serial Interface: 9 pin Female D-Sub Connector</p> <p>CEX Input: Female type BNC connector, 3 to 8V Peak-to-Peak sine wave, 50 Ohms Nominal Impedance at specified operating frequency.</p> <p>CEX Output: Female type BNC connector, 5 to 8V Peak-to-Peak into 50 Ohms at specified operating frequency.</p> <p>VALVE: 4-Pin Male Disk-Drive Connector</p>
Power Monitor Scaling:	<p>Forward Power Monitor: Monitor output is linearly proportional to 0 to 2000 Watts of forward power.</p> <p>Output scaling is 5.0VDC at 2000 Watts (2.5mV/Watt) or 10.0VDC at 2000 Watts (5.0mV/Watt), depending on the analog voltage range selected. (Default scaling)</p>

R2001 Specifications

Reflected Power Monitor	Monitor output is linearly proportional to 0 to 200 Watts of reflected power. Output scaling is 5.0VDC at 200 Watts (25mV/Watt) or 10.0VDC at 200 Watts (50mV/Watt), depending on the analog voltage range selected. (Default scaling)				
Analog Setpoint Sensitivity:	In Power Control mode, analog setpoint sensitivity is 2000 Watts at 5.0VDC (2.5mV per Watt) or 2000 Watts at 10.0VDC (5.0mV per Watt), depending on the analog voltage range selected.				
Labels:	<table border="0" style="width: 100%;"> <tr> <td style="vertical-align: top; padding-right: 20px;">Safety:</td> <td>Per customer requirements. Labels may include Hazardous Voltage, Heavy Object</td> </tr> <tr> <td style="vertical-align: top; padding-right: 20px;">Identification:</td> <td>Seren IPS Inc. part number, serial number, and customer part number (optional), RF output frequency</td> </tr> </table>	Safety:	Per customer requirements. Labels may include Hazardous Voltage, Heavy Object	Identification:	Seren IPS Inc. part number, serial number, and customer part number (optional), RF output frequency
Safety:	Per customer requirements. Labels may include Hazardous Voltage, Heavy Object				
Identification:	Seren IPS Inc. part number, serial number, and customer part number (optional), RF output frequency				
Battery:	Internal, 3V 255mAh, 23mm Coin Style, Type BR2330 or CR2330 (For retention of user-configurable settings)				
Supplied Accessories:	Solenoid Water Valve Product Information CD-ROM				
Dimensions inch (mm):	7.00 (177.80) High x 19.00 (482.60) Wide x 22.75 (577.85) Deep. Width includes Rack Mounting Brackets. Width without Rack Mounting Brackets: 17.00 (431.80) Depth includes Mains Power Connection Terminal Box				
Weight:	55 Lbs (24.9Kg)				

R2001H Specifications

AC Mains Input Power	Available Options, specify at time of order:	
	<ol style="list-style-type: none"> 1. Nominal Voltage Rating: 208-240V, Single Phase Operating Voltage Range: 190-264V, Single Phase 2. Nominal Voltage Rating: 208-240V, Three-Phase 4-Wire Delta Operating Voltage Range: 190-264V, Three Phase 4-Wire Delta 3. Nominal Voltage Rating: 380-415V, Three Phase 5-Wire Wye Operating Voltage Range: 342-457V, Three Phase 5-Wire Wye 	
	There are no transformer voltage taps to configure. Input power is not field-configurable.	
	Frequency:	47-63 HZ
	Current (FLA):	208-240V Single Phase: 30A Maximum 208-240V Three Phase 4-Wire Delta: 25A Per Phase Maximum 380-415V Three Phase 5-Wire Wye: 12A Per Phase Maximum
	Power required:	5700VA Maximum
	Overcurrent Protection:	Rear Panel Circuit Breaker, 2x 1.5A ¼"x1-1/4" time-delay fuses.
	Short Circuit Current Rating (SCCR)	10KA
	Note: For SEMI S2 compliance, the system power distribution panel or system integrator must supply an over-current protection device (fuse or circuit breaker) with a minimum interrupting capacity of 10,000A (10,000AIC).	
Power Cord and Power Plug:	208-240V Single Phase:	Cord: Captive, 10 AWG, 3 Conductor, Type SOW, 6 foot (1.82m) length Plug: NEMA Type L6-30P locking connector
	208-240V Three Phase 4-Wire Delta:	Cord: Captive, 12 AWG, 4 Conductor, Type SOW, 6 foot (1.82m) length Plug: NEMA Type L15-30P locking connector
	380-415V Three Phase 5-Wire Wye:	Cord: Captive, 12 AWG, 5 Conductor, Type SOOW, 10 foot (3.05m) length Plug: None Supplied. The installer is responsible for connecting and/or terminating the power cord in accordance with applicable national and local codes.

R2001H Specifications

Output:	Power:	0 to 2000 Watts into 50 Ohms
	Maximum Reflected Power:	500 Watts
	Frequency:	13.56MHz Fixed (standard), Optional Frequencies (specify at time of order): 1.7-2.1MHz Variable (1 KHz Steps) Frequency Synthesized, 27.12MHz Fixed, 40.68MHz Fixed
	Leveling:	Forward Power, Load (Net) Power, External Feedback (RF or DC Probe)
	RF Output Connector:	Type N, HN, or 7/16 DIN female. Customer Specified
	Power Stability:	0.5% Long Term, +/- 1 Watt
	Output Impedance:	50 Ohms, +/-5 Ohms Nominal
	Metering Accuracy: (Forward Power)	+/- 2% of Reading, +/- 1 Watt
	Temperature Coefficient:	0.25% per °C
	Forward Power Regulation:	+/- 1% into 50 Ohms
	Load Tolerance:	No oscillation or failure into a mismatch condition.
	Protection:	Forward power limits on current, transistor power dissipation, and excessive reflected power. Unit is short-circuit and open-circuit protected. Unit is thermally protected.
	Spurious Radiation:	Designed to meet or exceed FCC requirements.
	Harmonics:	-50dBc
	Noise, Hum, and Ripple:	-50dBc
	Pulsing:	20Hz to 10KHz, 1-Hz Steps; 0 to 100% duty cycle; 50 micro-second minimum pulse

R2001H Specifications

Environment:	Operating:	<p>Ambient Temperature: +5°C to +40°C</p> <p>Relative Humidity: 10% to 90% non-condensing, non-icing</p> <p>Atmospheric Pressure: 683 mBar minimum (approx 3000m above sea level)</p> <p>Pollution Degree: 2 or cleaner.</p>
	Storage:	<p>Ambient Temperature: -25°C to +55°C</p> <p>Relative Humidity: 5% to 95%, non-condensing</p> <p>Atmospheric Pressure: 585 mBar minimum (approx 4000m above sea level)</p>
	Transportation:	<p>Ambient Temperature: -25°C to +70°C</p> <p>Relative Humidity: 95% Maximum absolute humidity when unit temperature directly decreases from +70°C to +15°C</p> <p>Atmospheric Pressure: 480 mBar minimum (approx 5000m above sea level)</p>
Cooling:	Ventilation:	<p>Forced Air, 150 CFM (70.79 L/Sec), intake at sides, exhaust at rear panel. Observe specified panel clearances and mounting instructions.</p>
	Coolant Water:	<p>Flow: 2.0 gallons/minute (7.57 L/min) minimum.</p> <p>Inlet Temperature: +15°C minimum to +40°C maximum temperature, +22°C to +28°C recommended.</p> <p>Pressure: 70 PSI (482.63 kPa) maximum</p>
	Coolant Water Purity:	<p>pH: Between 7 and 9</p> <p>Total Chlorine: <20ppm</p> <p>Total Nitrate: <10ppm</p> <p>Total Sulfate: <100ppm</p> <p>Total Dissolved Solids: <250ppm</p> <p>Total Hardness expressed as Calcium Carbonate equivalent: <250ppm</p> <p>Specific Resistivity: >2500 Ohms/cm @ +25°C</p>
	Coolant Water Fittings:	<p>Type 3/8" N.P.T. Female threaded pipe</p>

R2001H Specifications

Coolant Water Supply Line Inside Diameter:	3/8" [9.52mm] Inside Diameter (I.D.) or larger.
Waste Heat into Coolant Water	1600 Watts (91 BTU/minute) maximum Note: The waste heat does not peak at 2000 Watts of output power - the waste heat peaks at 50% to 80% of full power or under certain reflected power conditions.
Interlocks:	<p>External: External interlock provided for disabling RF output power</p> <p>Valve (optional): Prevents/disables RF Power output if external water valve is missing or un plugged. (standard units ignore this interlock – consult factory if valve interlock is required)</p>
Interface Connections:	<p>Analog Interface: 25 pin Female D-Sub Connector</p> <p>Serial Interface: 9 pin Female D-Sub Connector</p>
CEX Input:	Female type BNC connector, 3 to 8V Peak-to-Peak sine wave, 50 Ohms Nominal Impedance at specified operating frequency.
CEX Output:	Female type BNC connector, 5 to 8V Peak-to-Peak into 50 Ohms at specified operating frequency.
VALVE	4-Pin Male Disk-Drive Connector
Power Monitor Scaling:	<p>Forward Power Monitor Monitor output is linearly proportional to 0 to 2000 Watts of forward power.</p> <p>Output scaling is 5.0VDC at 2000 Watts (2.5mV/Watt) or 10.0VDC at 2000 Watts (5.0mV/Watt), depending on the analog voltage range selected. (Default scaling)</p>

R2001H Specifications

Reflected Power Monitor	Monitor output is linearly proportional to 0 to 500 Watts of reflected power. Output scaling is 5.0VDC at 500 Watts (10mV/Watt) or 10.0VDC at 500 Watts (20mV/Watt), depending on the analog voltage range selected. (Default scaling)				
Analog Setpoint Sensitivity:	In Power Control mode, analog setpoint sensitivity is 2000 Watts at 5.0VDC (2.5mV per Watt) or 2000 Watts at 10.0VDC (5.0mV per Watt), depending on the analog voltage range selected.				
Labels:	<table border="0"> <tr> <td style="vertical-align: top;">Safety:</td> <td>Per customer requirements. Labels may include Hazardous Voltage, Heavy Object</td> </tr> <tr> <td style="vertical-align: top;">Identification:</td> <td>Seren IPS Inc. part number, serial number, and customer part number (optional), RF output frequency</td> </tr> </table>	Safety:	Per customer requirements. Labels may include Hazardous Voltage, Heavy Object	Identification:	Seren IPS Inc. part number, serial number, and customer part number (optional), RF output frequency
Safety:	Per customer requirements. Labels may include Hazardous Voltage, Heavy Object				
Identification:	Seren IPS Inc. part number, serial number, and customer part number (optional), RF output frequency				
Battery:	Internal, 3V 255mAh, 23mm Coin Style, Type BR2330 or CR2330 (For retention of user-configurable settings)				
Supplied Accessories:	Solenoid Water Valve Product Information CD-ROM				
Dimensions inch (mm):	7.00 (177.80) High x 19.00 (482.60) Wide x 22.75 (577.85) Deep. Width includes Rack Mounting Brackets. Width without Rack Mounting Brackets: 17.00 (431.80) Depth includes Mains Power Connection Terminal Box				
Weight:	70 Lbs (31.74Kg)				

L2001 Specifications

AC Mains Input Power	Available Options, specify at time of order:	
	<ol style="list-style-type: none"> 1. Nominal Voltage Rating: 208-240V, Single Phase Operating Voltage Range: 190-264V, Single Phase 2. Nominal Voltage Rating: 208-240V, Three-Phase 4-Wire Delta Operating Voltage Range: 190-264V, Three Phase 4-Wire Delta 3. Nominal Voltage Rating: 380-415V, Three Phase 5-Wire Wye Operating Voltage Range: 342-457V, Three Phase 5-Wire Wye 	
	There are no transformer voltage taps to configure.	
	Input power is not field-configurable.	
	Frequency:	47-63 HZ
	Current (FLA):	208-240V Single Phase: 20A Maximum 208-240V Three Phase 4-Wire Delta: 20A Per Phase Maximum 380-415V, Three Phase 5-Wire Wye: 10A Per Phase Maximum
	Power required:	3375VA Maximum
	Short Circuit Current Rating (SCCR)	10KA
	Overcurrent Protection:	Rear Panel Circuit Breaker, 2x 1.5A ¼"x1-1/4" time-delay fuses.
	Note: For SEMI S2 compliance, the system power distribution panel or system integrator must supply an over-current protection device (fuse or circuit breaker) with a minimum interrupting capacity of 10,000A (10,000AIC).	
Power Cord and Power Plug:	208-240V Single Phase:	Cord: Captive, 12 AWG, 3 Conductor, Type SOW, 6 foot (1.82m) length Plug: NEMA Type L6-20P locking connector
	208-240V Three Phase 4-Wire Delta:	Cord: Captive, 12 AWG, 4 Conductor, Type SOW, 6 foot (1.82m) length Plug: NEMA Type L15-20P locking connector
	380-415V Three Phase 5-Wire Wye:	Cord: Captive, 12 AWG, 5 Conductor, Type SOOW, 10 foot (3.05m) length Plug: None Supplied. The installer is responsible for connecting and/or terminating the power cord in accordance with applicable national and local codes.

L2001 Specifications

Output:	Power:	0 to 2000 Watts into 50 Ohms
	Maximum Reflected Power:	200 Watts
	Frequency:	350KHz to 460KHz, variable, 1 KHz steps, frequency synthesized. Other frequency ranges available; consult the factory or local Seren IPS sales representative.
	Leveling:	Forward Power, Load (Net) Power, External Feedback (RF or DC Probe)
	RF Output Connector:	Type N or HN, Customer Specified
	Power Stability:	0.5% Long Term, +/- 1 Watt
	Output Impedance:	50 Ohms, +/-5 Ohms Nominal
	Metering Accuracy: (Forward Power)	+/- 2% of Reading, +/- 1 Watt
	Temperature Coefficient:	0.25% per °C
	Forward Power Regulation:	+/- 1% into 50 Ohms
	Load Tolerance:	No oscillation or failure into a mismatch condition.
	Protection:	Forward power limits on current, transistor power dissipation, and excessive reflected power. Unit is short-circuit and open-circuit protected. Unit is thermally protected.
	Spurious Radiation:	Designed to meet or exceed FCC requirements.
	Harmonics:	Equal to or less than -40dBc at maximum output frequency
	Noise, Hum, and Ripple:	Equal to or less than -50dBc
	Pulsing:	20Hz to 10KHz, 1-Hz Steps; 0 to 100% duty cycle; 50 micro-second minimum pulse

L2001 Specifications

Environment:	Operating:	<p>Ambient Temperature: +5°C to +40°C</p> <p>Relative Humidity: 10% to 90% non-condensing, non-icing</p> <p>Atmospheric Pressure: 683 mBar minimum (approx 3000m above sea level)</p> <p>Pollution Degree: 2 or cleaner.</p>
	Storage:	<p>Ambient Temperature: -25°C to +55°C</p> <p>Relative Humidity: 5% to 95%, non-condensing</p> <p>Atmospheric Pressure: 585 mBar minimum (approx 4000m above sea level)</p>
	Transportation:	<p>Ambient Temperature: -25°C to +70°C</p> <p>Relative Humidity: 95% Maximum absolute humidity when unit temperature directly decreases from +70°C to +15°C</p> <p>Atmospheric Pressure: 480 mBar minimum (approx 5000m above sea level)</p>
Cooling:	Ventilation:	<p>Forced Air, 150 CFM (70.79 L/Sec), intake at sides, exhaust at rear panel. Observe specified panel clearances and mounting instructions</p>
	Coolant Water:	<p>Flow: 2.0 gallons/minute (7.57 L/min) minimum.</p> <p>Inlet Temperature: +15°C minimum to +40°C maximum temperature, +22°C to +28°C recommended.</p> <p>Pressure: 70 PSI (482.63 kPa) maximum</p>
	Coolant Water Purity:	<p>pH: Between 7 and 9</p> <p>Total Chlorine: <20ppm</p> <p>Total Nitrate: <10ppm</p> <p>Total Sulfate: <100ppm</p> <p>Total Dissolved Solids: <250ppm</p> <p>Total Hardness expressed as Calcium Carbonate equivalent: <250ppm</p> <p>Specific Resistivity: >2500 Ohms/cm @ +25°C</p>
	Coolant Water Fittings:	<p>Type 3/8" N.P.T. Female threaded pipe</p>

L2001 Specifications

Coolant Water Supply Line Inside Diameter:	3/8" [9.52mm] Inside Diameter (I.D.) or larger.
Waste Heat into Coolant Water	<p>2000 Watts maximum.</p> <p>Note: The waste heat does not peak at 2000 Watts of output power - the waste heat peaks at 50% to 80% of full power or under certain reflected power conditions.</p>
Interlocks:	<p>External: External interlock provided for disabling RF output power</p> <p>Valve (optional): Prevents/disables RF Power output if external water valve is missing or un-plugged. (Standard units ignore this interlock – consult factory if valve interlock is required)</p>
Interface Connections:	<p>Analog Interface: 25 pin Female D-Sub Connector</p> <p>Serial Interface: 9 pin Female D-Sub Connector</p> <p>CEX Input: Female type BNC connector, 3 to 8V Peak-to-Peak sine wave, 50 Ohms Nominal Impedance at specified operating frequency.</p> <p>CEX Output: Female type BNC connector, 5 to 8V Peak-to-Peak into 50 Ohms at specified operating frequency.</p> <p>VALVE 4-Pin Male Disk-Drive Connector</p>
Power Monitor Scaling:	<p>Forward Power Monitor Monitor output is linearly proportional to 0 to 2000 Watts of forward power.</p> <p>Output scaling is 5.0VDC at 2000 Watts (2.5mV/Watt) or 10.0VDC at 2000 Watts (5.0mV/Watt), depending on the analog voltage range selected. (Default scaling)</p>

L2001 Specifications

	Reflected Power Monitor	Monitor output is linearly proportional to 0 to 200 Watts of reflected power. Output scaling is 5.0VDC at 200 Watts (25mV/Watt) or 10.0VDC at 200 Watts (50mV/Watt), depending on the analog voltage range selected. (Default scaling)
Analog Setpoint Sensitivity:		In Power Control mode, analog setpoint sensitivity is 2000 Watts at 5.0VDC (2.5mV per Watt) or 2000 Watts at 10.0VDC (5.0mV per Watt), depending on the analog voltage range selected.
Labels:	Safety:	Per customer requirements. Labels may include Hazardous Voltage, Heavy Object
	Identification:	Seren IPS Inc. part number, serial number, and customer part number (optional), RF output frequency
Battery:		Internal, 3V 255mAh, 23mm Coin Style, Type BR2330 or CR2330 (For retention of user-configurable settings)
Supplied Accessories:		Solenoid Water Valve Product Information CD-ROM
Dimensions inch (mm):		7.00 (177.80) High x 19.00 (482.60) Wide x 22.75 (577.85) Deep. Width includes Rack Mounting Brackets. Width without Rack Mounting Brackets: 17.00 (431.80) Depth includes Mains Power Connection Terminal Box
Weight:		55 Lbs (24.9Kg)

L2001H Specifications

AC Mains	Available Options, specify at time of order:	
Input Power	<ol style="list-style-type: none"> 1. Nominal Voltage Rating: 208-240V, Single Phase Operating Voltage Range: 190-264V, Single Phase 2. Nominal Voltage Rating: 208-240V, Three-Phase 4-Wire Delta Operating Voltage Range: 190-264V, Three Phase 4-Wire Delta 3. Nominal Voltage Rating: 380-415V, Three Phase 5-Wire Wye Operating Voltage Range: 342-457V, Three Phase 5-Wire Wye <p>There are no transformer voltage taps to configure. Input power is not field-configurable.</p>	
	Frequency:	47-63 HZ
	Current (FLA):	208-240V Single Phase: 30A Maximum 208-240V Three Phase 4-Wire Delta: 25A Per Phase Maximum 380-415V, Three Phase 5-Wire Wye: 12A Per Phase Maximum
	Power required:	5700VA Maximum
	Overcurrent Protection:	Rear Panel Circuit Breaker, 2x 1.5A ¼"x1-1/4" time-delay fuses.
	Short Circuit Current Rating (SCCR)	10KA
	Note: For SEMI S2 compliance, the system power distribution panel or system integrator must supply an over-current protection device (fuse or circuit breaker) with a minimum interrupting capacity of 10,000A (10,000AIC).	
Power Cord and Power Plug:	208-240V Single Phase:	<p>Cord: Captive, 10 AWG, 3 Conductor, Type SOW, 6 foot (1.82m) length Plug: NEMA Type L6-30P locking connector</p>
	208-240V Three-Phase 4-Wire Delta:	<p>Cord: Captive, 12 AWG, 4 Conductor, Type SOW, 6 foot (1.82m) length, Plug: NEMA Type L15-30P locking connector</p>
	380-415V, Three Phase 5-Wire Wye:	<p>Cord: Captive, 12 AWG, 5 Conductor, Type SOOW, 10 foot (3.05m) length Plug: None Supplied. The installer is responsible for connecting and/or terminating the power cord in accordance with applicable national and local codes.</p>

L2001H Specifications

Output:	Power:	0 to 2000 Watts into 50 Ohms
	Maximum Reflected Power:	500 Watts
	Frequency:	350KHz to 460KHz, variable, 1 KHz steps, frequency synthesized. Other frequency ranges available; consult the factory or local Seren IPS sales representative.
	Leveling:	Forward Power, Load (Net) Power, External Feedback (RF or DC Probe)
	RF Output Connector:	Type N or HN, Customer Specified
	Power Stability:	0.5% Long Term, +/- 1 Watt
	Output Impedance:	50 Ohms, +/-5 Ohms Nominal
	Metering Accuracy: (Forward Power)	+/- 2% of Reading, +/- 1 Watt
	Temperature Coefficient:	0.25% per °C
	Forward Power Regulation:	+/- 1% into 50 Ohms
	Load Tolerance:	No oscillation or failure into a mismatch condition.
	Protection:	Forward power limits on current, transistor power dissipation, and excessive reflected power. Unit is short-circuit and open-circuit protected. Unit is thermally protected.
	Spurious Radiation:	Designed to meet or exceed FCC requirements.
	Harmonics:	Equal to or less than -40dBc at maximum output frequency
	Noise, Hum, and Ripple:	Equal to or less than -50dBc
	Pulsing:	20Hz to 10KHz, 1-Hz Steps; 0 to 100% duty cycle; 50 micro-second minimum pulse

L2001H Specifications

Environment:	Operating:	<p>Ambient Temperature: +5°C to +40°C</p> <p>Relative Humidity: 10% to 90% non-condensing, non-icing</p> <p>Atmospheric Pressure: 683 mBar minimum (approx 3000m above sea level)</p> <p>Pollution Degree: 2 or cleaner.</p>
	Storage:	<p>Ambient Temperature: -25°C to +55°C</p> <p>Relative Humidity: 5% to 95%, non-condensing</p> <p>Atmospheric Pressure: 585 mBar minimum (approx 4000m above sea level)</p>
	Transportation:	<p>Ambient Temperature: -25°C to +70°C</p> <p>Relative Humidity: 95% Maximum absolute humidity when unit temperature directly decreases from +70°C to +15°C</p> <p>Atmospheric Pressure: 480 mBar minimum (approx 5000m above sea level)</p>
Cooling:	Ventilation:	<p>Forced Air, 150 CFM (70.79 L/Sec), intake at sides, exhaust at rear panel. Observe specified panel clearances and mounting instructions</p>
	Coolant Water:	<p>Flow: 2.0 gallons/minute (7.57 L/min) minimum.</p> <p>Inlet Temperature: +15°C minimum to +40°C maximum temperature, +22°C to +28°C recommended.</p> <p>Pressure: 70 PSI (482.63 kPa) maximum</p>
	Coolant Water Purity:	<p>pH: Between 7 and 9</p> <p>Total Chlorine: <20ppm</p> <p>Total Nitrate: <10ppm</p> <p>Total Sulfate: <100ppm</p> <p>Total Dissolved Solids: <250ppm</p> <p>Total Hardness expressed as Calcium Carbonate equivalent: <250ppm</p> <p>Specific Resistivity: >2500 Ohms/cm @ +25°C</p>
	Coolant Water Fittings:	<p>Type 3/8" N.P.T. Female threaded pipe</p>

L2001H Specifications

Coolant Water Supply Line Inside Diameter:	3/8" [9.52mm] Inside Diameter (I.D.) or larger.
Waste Heat into Coolant Water	2000 Watts maximum. Note: The waste heat does not peak at 2000 Watts of output power - the waste heat peaks at 50% to 80% of full power or under certain reflected power conditions.
Interlocks:	<p>External: External interlock provided for disabling RF output power</p> <p>Valve (optional): Prevents/disables RF Power output if external water valve is missing or un-plugged. (Standard units ignore this interlock – consult factory if valve interlock is required)</p>
Interface Connections:	<p>Analog Interface: 25 pin Female D-Sub Connector</p> <p>Serial Interface: 9 pin Female D-Sub Connector</p> <p>CEX Input: Female type BNC connector, 3 to 8V Peak-to-Peak sine wave, 50 Ohms Nominal Impedance at specified operating frequency.</p> <p>CEX Output: Female type BNC connector, 5 to 8V Peak-to-Peak into 50 Ohms at specified operating frequency.</p> <p>VALVE: 4-Pin Male Disk-Drive Connector</p>
Power Monitor Scaling:	<p>Forward Power Monitor: Monitor output is linearly proportional to 0 to 2000 Watts of forward power.</p> <p>Output scaling is 5.0VDC at 2000 Watts (2.5mV/Watt) or 10.0VDC at 2000 Watts (5.0mV/Watt), depending on the analog voltage range selected. (Default scaling)</p>

L2001H Specifications

	Reflected Power Monitor	Monitor output is linearly proportional to 0 to 500 Watts of reflected power. Output scaling is 5.0VDC at 500 Watts (10mV/Watt) or 10.0VDC at 500 Watts (20mV/Watt), depending on the analog voltage range selected. (Default scaling)
Analog Setpoint Sensitivity:	In Power Control mode, analog setpoint sensitivity is 2000 Watts at 5.0VDC (2.5mV per Watt) or 2000 Watts at 10.0VDC (5.0mV per Watt), depending on the analog voltage range selected.	
Labels:	Safety:	Per customer requirements. Labels may include Hazardous Voltage, Heavy Object
	Identification:	Seren IPS Inc. part number, serial number, and customer part number (optional), RF output frequency
Battery:	Internal, 3V 255mAh, 23mm Coin Style, Type BR2330 or CR2330 (For retention of user-configurable settings)	
Supplied Accessories:	Solenoid Water Valve Product Information CD-ROM	
Dimensions inch (mm):	7.00 (177.80) High x 19.00 (482.60) Wide x 22.75 (577.85) Deep. Width includes Rack Mounting Brackets. Width without Rack Mounting Brackets: 17.00 (431.80) Depth includes Mains Power Connection Terminal Box	
Weight:	70 Lbs (31.74Kg)	

R3001 Specifications

AC Mains	Available Options, specify at time of order:	
Input Power	<ol style="list-style-type: none"> 1. Nominal Voltage Rating: 208-240V, Single-Phase Operating Voltage Range: 190-264V, Single-Phase 2. Nominal Voltage Rating: 208-240V, Three-Phase 4-Wire Delta Operating Voltage Range: 190-264V, Three Phase 4-Wire Delta 3. Nominal Voltage Rating: 380-415V, Three Phase 5-Wire Wye Operating Voltage Range: 342-457V, Three Phase 5-Wire Wye <p>There are no transformer voltage taps to configure. Input power is not field-configurable.</p>	
	Frequency:	47-63 HZ
	Current (FLA):	208-240V Single Phase: 30A Maximum 208-240V Three Phase 4-Wire Delta: 25A Per Phase Maximum 380-415V Three Phase 5-Wire Delta: 12A Per Phase Maximum
	Power required:	5700VA Maximum
	Overcurrent Protection:	Rear Panel Circuit Breaker, 2x 1.5A ¼"x1-1/4" time-delay fuses.
	Short Circuit Current Rating (SCCR)	10KA
	Note: For SEMI S2 compliance, the system power distribution panel or system integrator must supply an over-current protection device (fuse or circuit breaker) with a minimum interrupting capacity of 10,000A (10,000AIC).	
Power Cord and Power Plug:	208-240V Single Phase:	<p>Cord: Captive, 10 AWG, 3 Conductor, Type SOW, 6 foot (1.82m) length</p> <p>Plug: NEMA Type L6-30P locking connector</p>
	208-240V Three-Phase 4-Wire Delta:	<p>Cord: Captive, 12 AWG, 4 Conductor, Type SOOW, 6 foot (1.82m) length</p> <p>Plug: NEMA Type L15-30P locking connector</p>
	380-415V Three-Phase 5-Wire Wye:	<p>Cord: Captive, 12 AWG, 5 Conductor, Type SOOW, 10 foot (3.05m) length</p> <p>Plug: None Supplied. The installer is responsible for connecting and/or terminating the power cord in accordance with applicable national and local codes</p>

R3001 Specifications

Output:	Power:	0 to 3000 Watts into 50 Ohms
	Maximum Reflected Power:	200 Watts
	Frequency:	13.56MHz Fixed (standard), Optional Frequencies (specify at time of order): 1.7-2.1MHz Variable (1 KHz Steps) Frequency Synthesized, 27.12MHz Fixed, 40.68MHz Fixed
	Leveling:	Forward Power, Load (Net) Power, External Feedback (RF or DC Probe)
	RF Output Connector:	Type HN, or 7/16 DIN female. Customer Specified
	Power Stability:	0.5% Long Term, +/- 1 Watt
	Output Impedance:	50 Ohms, +/-5 Ohms Nominal
	Metering Accuracy: (Forward Power)	+/- 2% of Reading, +/- 1 Watt
	Temperature Coefficient:	0.25% per °C
	Forward Power Regulation:	+/- 1% into 50 Ohms
	Load Tolerance:	No oscillation or failure into a mismatch condition.
	Protection:	Forward power limits on current, transistor power dissipation, and excessive reflected power. Unit is short-circuit and open-circuit protected. Unit is thermally protected.
	Spurious Radiation:	Designed to meet or exceed FCC requirements.
	Harmonics:	-50dBc
	Noise, Hum, and Ripple:	-50dBc
	Pulsing:	20Hz to 10KHz, 1-Hz Steps; 0 to 100% duty cycle, 50 micro-second minimum pulse

R3001 Specifications

Environment:	Operating:	<p>Ambient Temperature: +5°C to +40°C</p> <p>Relative Humidity: 10% to 90% non-condensing, non-icing</p> <p>Atmospheric Pressure: 683 mBar minimum (approx 3000m above sea level)</p> <p>Pollution Degree: 2 or cleaner.</p>
	Storage:	<p>Ambient Temperature: -25°C to +55°C</p> <p>Relative Humidity: 5% to 95%, non-condensing</p> <p>Atmospheric Pressure: 585 mBar minimum (approx 4000m above sea level)</p>
	Transportation:	<p>Ambient Temperature: -25°C to +70°C</p> <p>Relative Humidity: 95% Maximum absolute humidity when unit temperature directly decreases from +70°C to +15°C</p> <p>Atmospheric Pressure: 480 mBar minimum (approx 5000m above sea level)</p>
Cooling:	Ventilation:	<p>Forced Air, 150 CFM (70.79 L/Sec), intake at sides, exhaust at rear panel. Observe specified panel clearances and mounting instructions</p>
	Coolant Water:	<p>Flow: 2.0 gallons/minute (7.57 L/min) minimum.</p> <p>Inlet Temperature: +15°C minimum to +40°C maximum temperature, +22°C to +28°C recommended.</p> <p>Pressure: 70 PSI (482.63 kPa) maximum</p>
	Coolant Water Purity:	<p>pH: Between 7 and 9</p> <p>Total Chlorine: <20ppm</p> <p>Total Nitrate: <10ppm</p> <p>Total Sulfate: <100ppm</p> <p>Total Dissolved Solids: <250ppm</p> <p>Total Hardness expressed as Calcium Carbonate equivalent: <250ppm</p> <p>Specific Resistivity: >2500 Ohms/cm @ +25°C</p>
	Coolant Water Fittings:	<p>Type 3/8" N.P.T. Female threaded pipe</p>

R3001 Specifications

Coolant Water Supply Line Inside Diameter:	3/8" [9.52mm] Inside Diameter (I.D.) or larger.
Waste Heat into Coolant Water	2000 Watts (114 BTU/minute) maximum. Note: The waste heat does not peak at 3000 Watts of output power - the waste heat peaks at 50% to 80% of full power or under certain reflected power conditions.
Interlocks:	<p>External: External interlock provided for disabling RF output power</p> <p>Valve (optional): Prevents/disables RF Power output if external water valve is missing or un plugged. (standard units ignore this interlock – consult factory if valve interlock is required)</p>
Interface Connections:	<p>Analog Interface: 25 pin Female D-Sub Connector</p> <p>Serial Interface: 9 pin Female D-Sub Connector</p> <p>CEX Input: Female type BNC connector, 3 to 8V Peak-to-Peak sine wave, 50 Ohms Nominal Impedance at specified operating frequency.</p> <p>CEX Output: Female type BNC connector, 5 to 8V Peak-to-Peak into 50 Ohms at specified operating frequency.</p> <p>VALVE 4-Pin Male Disk-Drive Connector</p>
Power Monitor Scaling:	<p>Forward Power Monitor Monitor output is linearly proportional to 0 to 3000 Watts of forward power.</p> <p>Output scaling is 5.0VDC at 3000 Watts (1.66mV/Watt) or 10.0VDC at 3000 Watts (3.33mV/Watt), depending on the analog voltage range selected. (Default scaling)</p>

R3001 Specifications

	Reflected Power Monitor	Monitor output is linearly proportional to 0 to 200 Watts of reflected power. Output scaling is 5.0VDC at 200 Watts (25mV/Watt) or 10.0VDC at 200 Watts (50mV/Watt), depending on the analog voltage range selected. (Default scaling)
Analog Setpoint Sensitivity:	In Power Control mode, analog setpoint sensitivity is 3000 Watts at 5.0VDC (1.66mV per Watt) or 3000 Watts at 10.0VDC (3.33mV per Watt), depending on the analog voltage range selected.	
Labels:	Safety:	Per customer requirements. Labels may include Hazardous Voltage, Heavy Object
	Identification:	Seren IPS Inc. part number, serial number, and customer part number (optional), RF output frequency
Battery:	Internal, 3V 255mAh, 23mm Coin Style, Type BR2330 or CR2330 (For retention of user-configurable settings)	
Supplied Accessories:	Solenoid Water Valve Product Information CD-ROM	
Dimensions inch (mm):	7.00 (177.80) High x 19.00 (482.60) Wide x 22.75 (577.85) Deep. Width includes Rack Mounting Brackets. Width without Rack Mounting Brackets: 17.00 (431.80) Depth includes Mains Power Connection Terminal Box	
Weight:	70 Lbs (31.74Kg)	

L3001 Specifications

AC Mains Available Options, specify at time of order:
 Input Power

1. Nominal Voltage Rating: 208-240V, Single-Phase
 Operating Voltage Range: 190-264V, Single-Phase
2. Nominal Voltage Rating: 208-240V, Three-Phase 4-Wire Delta
 Operating Voltage Range: 190-264V, Three Phase 4-Wire Delta
3. Nominal Voltage Rating: 380-415V, Three Phase 5-Wire Wye
 Operating Voltage Range: 342-457V, Three Phase 5-Wire Wye

There are no transformer voltage taps to configure.
 Input power is not field-configurable.

Frequency: 47-63 HZ

Current (FLA): 208-240V, Single-Phase: 30A Maximum
 208-240V Three Phase 4-Wire Delta:
 25A Per Phase Maximum
 380-415V, Three Phase 5-Wire Wye:
 12A Per Phase Maximum

Power required: 5700VA Maximum

Overcurrent Protection: Rear Panel Circuit Breaker,
 2x 1.5A ¼"x1-1/4" time-delay fuses.

Short Circuit Current Rating (SCCR) 10KA

Note: For SEMI S2 compliance, the system power distribution panel or system integrator must supply an over-current protection device (fuse or circuit breaker) with a minimum interrupting capacity of 10,000A (10,000AIC).

Power Cord and Power Plug:	208-240V Single Phase:	Cord: Captive, 10AWG, 3 Conductor, Type SOW, 6 foot (1.82m) length Plug: NEMA Type L6-30P locking connector
	208-240V Three Phase 4-Wire Delta:	Cord: Captive, 12 AWG, 4 Conductor, Type SOW, 6 foot (1.82m) length Plug: NEMA Type L15-30P locking connector
	380-415V Three Phase 5-Wire Wye:	Cord: Captive, 12AWG, 5 Conductor, Type SOOW, 10 foot (3.05m) length Plug: None Supplied. The installer is responsible for connecting and/or terminating the power cord in accordance with applicable national and local codes.

L3001 Specifications

Output:	Power:	High Range: 0 to 3000 Watts into 50 Ohms Low Range: 0 to 300 Watts into 50 Ohms
	Maximum Reflected Power:	200 Watts
	Frequency:	350KHz to 460KHz, variable, 1 KHz steps, frequency synthesized. Other frequency ranges available; consult the factory or local Seren IPS sales representative.
	Leveling:	Forward Power, Load (Net) Power, External Feedback (RF or DC Probe)
	RF Output Connector:	Type HN, or 7/16 DIN female. Customer Specified
	Power Stability:	0.5% Long Term, +/- 1 Watt
	Output Impedance:	50 Ohms, +/-5 Ohms Nominal
	Metering Accuracy: (Forward Power)	+/- 2% of Reading, +/- 1 Watt
	Temperature Coefficient:	0.25% per °C
	Forward Power Regulation:	+/- 1% into 50 Ohms
	Load Tolerance:	No oscillation or failure into a mismatch condition.
	Protection:	Forward power limits on current, transistor power dissipation, and excessive reflected power. Unit is short-circuit and open-circuit protected. Unit is thermally protected.
	Spurious Radiation:	Designed to meet or exceed FCC requirements.
	Harmonics:	Equal to or less than -40dBc at maximum output frequency
	Noise, Hum, and Ripple:	Equal to or less than -50dBc
	Pulsing:	20Hz to 10KHz, 1-Hz Steps; 0 to 100% duty cycle; 50 micro-second minimum pulse

L3001 Specifications

Environment:	Operating:	<p>Ambient Temperature: +5°C to +40°C</p> <p>Relative Humidity: 10% to 90% non-condensing, non-icing</p> <p>Atmospheric Pressure: 683 mBar minimum (approx 3000m above sea level)</p> <p>Pollution Degree: 2 or cleaner.</p>
	Storage:	<p>Ambient Temperature: -25°C to +55°C</p> <p>Relative Humidity: 5% to 95%, non-condensing</p> <p>Atmospheric Pressure: 585 mBar minimum (approx 4000m above sea level)</p>
	Transportation:	<p>Ambient Temperature: -25°C to +70°C</p> <p>Relative Humidity: 95% Maximum absolute humidity when unit temperature directly decreases from +70°C to +15°C</p> <p>Atmospheric Pressure: 480 mBar minimum (approx 5000m above sea level)</p>
Cooling:	Ventilation:	<p>Forced Air, 150 CFM (70.79 L/Sec), intake at sides, exhaust at rear panel. Observe specified panel clearances and mounting instructions</p>
	Coolant Water:	<p>Flow: 2.0 gallons/minute (7.57 L/min) minimum.</p> <p>Inlet Temperature: +15°C minimum to +40°C maximum temperature, +22°C to +28°C recommended.</p> <p>Pressure: 70 PSI (482.63 kPa) maximum</p>
	Coolant Water Purity:	<p>pH: Between 7 and 9</p> <p>Total Chlorine: <20ppm</p> <p>Total Nitrate: <10ppm</p> <p>Total Sulfate: <100ppm</p> <p>Total Dissolved Solids: <250ppm</p> <p>Total Hardness expressed as Calcium Carbonate equivalent: <250ppm</p> <p>Specific Resistivity: >2500 Ohms/cm @ +25°C</p>
	Coolant Water Fittings:	<p>Type 3/8" N.P.T. Female threaded pipe</p>
	Coolant Water Supply Line Inside Diameter:	<p>3/8" [9.52mm] Inside Diameter (I.D.) or larger.</p>

L3001 Specifications

	Waste Heat into Coolant Water	2000 Watts (114 BTU/minute) maximum. Note: The waste heat does not peak at 3000 Watts of output power - the waste heat peaks at 50% to 80% of full power or under certain reflected power conditions.
Interlocks:	External:	External interlock provided for disabling RF output power
	Valve (optional):	Prevents/disables RF Power output if external water valve is missing or un-plugged. (standard units ignore this interlock – consult factory if valve interlock is required)
Interface Connections:	Analog Interface:	25 pin Female D-Sub Connector
	Serial Interface:	9 pin Female D-Sub Connector
	CEX Input:	Female type BNC connector, 3 to 8V Peak-to-Peak sine wave, 50 Ohms Nominal Impedance at specified operating frequency.
	CEX Output:	Female type BNC connector, 5 to 8V Peak-to-Peak into 50 Ohms at specified operating frequency.
	VALVE	4-Pin Male Disk-Drive Connector
Power Monitor Scaling:	Forward Power Monitor	Monitor output is linearly proportional to 0 to 3000 Watts of forward power. Output scaling is 5.0VDC at 3000 Watts (1.66mV/Watt) or 10.0VDC at 3000 Watts (3.33mV/Watt), depending on the analog voltage range selected. (Default scaling)
	Reflected Power Monitor	Monitor output is linearly proportional to 0 to 200 Watts of reflected power. Output scaling is 5.0VDC at 200 Watts (25mV/Watt) or 10.0VDC at 200 Watts (50mV/Watt), depending on the analog voltage range selected. (Default scaling)

L3001 Specifications

Analog Setpoint Sensitivity:	In Power Control mode, analog setpoint sensitivity is 3000 Watts at 5.0VDC (1.66mV per Watt) or 3000 Watts at 10.0VDC (3.33mV per Watt), depending on the analog voltage range selected.				
Labels:	<table border="0" style="width: 100%;"> <tr> <td style="vertical-align: top; padding-right: 20px;">Safety:</td> <td>Per customer requirements. Labels may include Hazardous Voltage, Heavy Object</td> </tr> <tr> <td style="vertical-align: top; padding-right: 20px;">Identification:</td> <td>Seren IPS Inc. part number, serial number, and customer part number (optional), RF output frequency</td> </tr> </table>	Safety:	Per customer requirements. Labels may include Hazardous Voltage, Heavy Object	Identification:	Seren IPS Inc. part number, serial number, and customer part number (optional), RF output frequency
Safety:	Per customer requirements. Labels may include Hazardous Voltage, Heavy Object				
Identification:	Seren IPS Inc. part number, serial number, and customer part number (optional), RF output frequency				
Battery:	Internal, 3V 255mAh, 23mm Coin Style, Type BR2330 or CR2330 (For retention of user-configurable settings)				
Supplied Accessories:	Solenoid Water Valve Product Information CD-ROM				
Dimensions inch (mm):	7.00 (177.80) High x 19.00 (482.60) Wide x 22.75 (577.85) Deep. Width includes Rack Mounting Brackets. Width without Rack Mounting Brackets: 17.00 (431.80) Depth includes Mains Power Connection Terminal Box				
Weight:	70 Lbs (31.74Kg)				

R4001 Specifications

AC Mains Available Options, specify at time of order:
 Input Power 1. Nominal Voltage Rating: 208-240V, Three-Phase 4-Wire Delta
 Operating Voltage Range: 190-264V, Three Phase 4-Wire Delta
 2. Nominal Voltage Rating: 380-415V, Three Phase 5-Wire Wye
 Operating Voltage Range: 342-457V, Three Phase 5-Wire Wye
 There are no transformer voltage taps to configure.
 Input power is not field-configurable.

Frequency: 47-63 HZ

Current (FLA): 208-240V Three Phase 4-Wire Delta:
 30A Per Phase Maximum

380-415V Three Phase 5-Wire Wye:
 25A Per Phase Maximum

Power required: 7700VA Maximum

Over-current Protection: Rear Panel Circuit Breaker,
 2x 1.5A 1/4"x1-1/4" time-delay fuses.

Short Circuit Current Rating (SCCR) 10KA

Note: For SEMI S2 compliance, the system power distribution panel or system integrator must supply an over-current protection device (fuse or circuit breaker) with a minimum interrupting capacity of 10,000A (10,000AIC).

Power Cord and Power Plug: 208-240V Three Phase 4-Wire Delta: Cord: Captive, 10 AWG, 4 Wire, Type SOW, 6 foot (1.82m) length.
 Plug: NEMA Type L15-30P locking connector

380-415V Three Phase 5-Wire Wye: Cord: Captive, 12AWG, 5 Conductor, Type SOOW, 10 foot (3.05m) length.
 Plug: None Supplied. The installer is responsible for connecting and/or terminating the power cord in accordance with applicable national and local codes.

R4001 Specifications

Output:	Power:	0 to 4000 Watts into 50 Ohms
	Maximum Reflected Power:	200 Watts
	Frequency:	13.56MHz or 27.12MHz, fixed (specify at time of order)
	Leveling:	Forward Power, Load (Net) Power, External Feedback (RF or DC Probe)
	RF Output Connector:	Type 7/16 DIN female.
	Power Stability:	0.5% Long Term, +/- 1 Watt
	Output Impedance:	50 Ohms, +/-5 Ohms Nominal
	Metering Accuracy: (Forward Power)	+/- 2% of Reading, +/- 1 Watt
	Temperature Coefficient:	0.25% per °C
	Forward Power Regulation:	+/- 1% into 50 Ohms
	Load Tolerance:	No oscillation or failure into a mismatch condition.
	Protection:	Forward power limits on current, transistor power dissipation, and excessive reflected power. Unit is short-circuit and open-circuit protected. Unit is thermally protected.
	Spurious Radiation:	Designed to meet or exceed FCC requirements.
	Harmonics:	-50dBc
	Noise, Hum, and Ripple:	-50dBc
	Pulsing:	20Hz to 10KHz, 1-Hz Steps; 0 to 100% duty cycle, 50 micro-second minimum pulse

R4001 Specifications

Environment:	Operating:	Ambient Temperature: +5°C to +40°C Relative Humidity: 10% to 90% non-condensing, non-icing Atmospheric Pressure: 683 mBar minimum (approx 3000m above sea level) Pollution Degree: 2 or cleaner.
	Storage:	Ambient Temperature: -25°C to +55°C Relative Humidity: 5% to 95%, non-condensing Atmospheric Pressure: 585 mBar minimum (approx 4000m above sea level)
	Transportation:	Ambient Temperature: -25°C to +70°C Relative Humidity: 95% Maximum absolute humidity when unit temperature directly decreases from +70°C to +15°C Atmospheric Pressure: 480 mBar minimum (approx 5000m above sea level)
Cooling:	Ventilation:	Forced Air, 150 CFM (70.79 L/Sec), intake at sides, exhaust at rear panel. Observe specified panel clearances and mounting instructions
	Coolant Water:	Flow: 2.0 gallons/minute (7.57 L/min) minimum. Inlet Temperature: +15°C minimum to +40°C maximum temperature, +22°C to +28°C recommended. Pressure: 70 PSI (482.63 kPa) maximum
	Coolant Water Purity:	pH: Between 7 and 9 Total Chlorine: <20ppm Total Nitrate: <10ppm Total Sulfate: <100ppm Total Dissolved Solids: <250ppm Total Hardness expressed as Calcium Carbonate equivalent: <250ppm Specific Resistivity: >2500 Ohms/cm @ +25°C
	Coolant Water Fittings:	Type 3/8" N.P.T. Female threaded pipe
	Coolant Water Supply Line Inside Diameter:	3/8" [9.52mm] Inside Diameter (I.D.) or larger.

R4001 Specifications

Waste Heat into Coolant Water	3100 Watts (176.29 BTU/minute) maximum.
	Note: The waste heat does not peak at 4000 Watts of output power - the waste heat peaks at 50% to 80% of full power or under certain reflected power conditions.
Interlocks:	
External:	External interlock provided for disabling RF output power
RF Output Connector	Paddle-Type interlock disables RF output if a RF cable is not connected to the RF output connector or is removed from the RF output connector.
Water Flow	Internal sensor prevents/disables RF output if coolant water flow is insufficient.
Valve	Prevents/disables RF Power output if external water valve is missing or un-plugged.
Interface Connections:	
Analog Interface:	25 pin Female D-Sub Connector
Serial Interface:	9 pin Female D-Sub Connector
CEX Input:	Female type BNC connector, 3 to 8V Peak-to-Peak sine wave, 50 Ohms Nominal Impedance at specified operating frequency.
CEX Output:	Female type BNC connector, 5 to 8V Peak-to-Peak into 50 Ohms at specified operating frequency.
VALVE	4-Pin Male Disk-Drive Connector
Power Monitor Scaling:	
Forward Power Monitor	Monitor output is linearly proportional to 0 to 4000 Watts of forward power. Output scaling is 5.0VDC at 4000 Watts (1.25mV/Watt) or 10.0VDC at 4000 Watts (2.50mV/Watt), depending on the analog voltage range selected. (Default scaling)

R4001 Specifications

	Reflected Power Monitor	Monitor output is linearly proportional to 0 to 200 Watts of reflected power. Output scaling is 5.0VDC at 200 Watts (25mV/Watt) or 10.0VDC at 200 Watts (50mV/Watt), depending on the analog voltage range selected. (Default scaling)
Analog Setpoint Sensitivity:	In Power Control mode, analog setpoint sensitivity is 4000 Watts at 5.0VDC (1.25mV per Watt) or 4000 Watts at 10.0VDC (2.50mV per Watt), depending on the analog voltage range selected.	
Labels:	Safety:	Per customer requirements. Labels may include Hazardous Voltage, Heavy Object
	Identification:	Seren IPS Inc. part number, serial number, and customer part number (optional), RF output frequency
Battery:	Internal, 3V 255mAh, 23mm Coin Style, Type BR2330 or CR2330 (For retention of user-configurable settings)	
Supplied Accessories:	Solenoid Water Valve Product Information CD-ROM	
Dimensions inch (mm):	7.00 (177.80) High x 19.00 (482.60) Wide x 25.63 (651.00) Deep. Width includes Rack Mounting Brackets. Width without Rack Mounting Brackets: 17.00 (431.80) Depth includes Mains Power Connection Terminal Box	
Weight:	70 Lbs (31.74Kg)	

R5001 Specifications - 4U Package (Part Number Series 960096XXXX)

AC Mains Input Power	Available Options, specify at time of order:	
	1. Nominal Voltage Rating: 208-240V, Three-Phase 4-Wire Delta Operating Voltage Range: 190-264V, Three Phase 4-Wire Delta 2. Nominal Voltage Rating: 380-415V, Three Phase 5-Wire Wye Operating Voltage Range: 342-457V, Three Phase 5-Wire Wye There are no transformer voltage taps to configure. Input power is not field-configurable.	
	Frequency:	47-63 HZ
	Current (FLA):	208-240V Three Phase 4-Wire Delta: 40A Per Phase Maximum 380-415V Three-Phase 5-Wire Wye: 25A Per Phase Maximum
	Power required:	9879VA Maximum
	Over-Current Protection:	Rear Panel Circuit Breaker, 2x 1.5A ¼"x1-1/4" time-delay fuses.
	Short Circuit Current Rating (SCCR)	10KA
	Note: For SEMI S2 compliance, the system power distribution panel or system integrator must supply an over-current protection device (fuse or circuit breaker) with a minimum interrupting capacity of 10,000A (10,000AIC).	
Power Cord:	208-240V Three Phase 4-Wire Delta:	Cord: Captive, 10 AWG, 4 Conductor, Type SOW, 10 foot (3.05m) length.
	380-415V Three-Phase 5-Wire Wye:	Cord: Captive, 12AWG, 5 Conductor, Type SOOW, 10 foot (3.05m) length.
Power Plug:	None Provided.	The installer is responsible for connecting and/or terminating the power cord in accordance with applicable national and local codes.

R5001 Specifications - 4U Package (Part Number Series 960096XXXX)

Output:	Power:	0 to 5000 Watts into 50 Ohms
	Maximum Reflected Power:	500 Watts
	Frequency:	13.56MHz Fixed (standard), Optional Frequencies (specify at time of order): 27.12MHz Fixed, 40.68MHz Fixed, or synthesized variable frequency options available. Other frequencies available - consult factory and specify at time of order.
	Leveling:	Forward Power, Load (Net) Power, External Feedback (RF or DC Probe)
	RF Output Connector:	Type 7/16 DIN, or LC female. Customer Specified
	Power Stability:	0.5% Long Term, +/- 1 Watt
	Output Impedance:	50 Ohms, +/-5 Ohms Nominal
	Metering Accuracy: (Forward Power)	+/- 2% of Reading, +/- 1 Watt
	Temperature Coefficient:	0.25% per °C
	Forward Power Regulation:	+/- 1% into 50 Ohms
	Load Tolerance:	No oscillation or failure into a mismatch condition.
	Protection:	Forward power limits on current, transistor power dissipation, and excessive reflected power. Unit is short-circuit and open-circuit protected. Unit is thermally protected.
	Spurious Radiation:	Designed to meet or exceed FCC requirements.
	Harmonics:	-50dBc
	Noise, Hum, and Ripple:	-50dBc
	Pulsing:	20Hz to 10KHz, 1-Hz Steps; 0 to 100% duty cycle; 50 micro-second minimum pulse

R5001 Specifications - 4U Package (Part Number Series 960096XXXX)

Environment:	Operating:	<p>Ambient Temperature: +5°C to +40°C</p> <p>Relative Humidity: 10% to 90% non-condensing, non-icing</p> <p>Atmospheric Pressure: 683 mBar minimum (approx 3000m above sea level)</p> <p>Pollution Degree: 2 or cleaner.</p>
	Storage:	<p>Ambient Temperature: -25°C to +55°C</p> <p>Relative Humidity: 5% to 95%, non-condensing</p> <p>Atmospheric Pressure: 585 mBar minimum (approx 4000m above sea level)</p>
	Transportation:	<p>Ambient Temperature: -25°C to +70°C</p> <p>Relative Humidity: 95% Maximum absolute humidity when unit temperature directly decreases from +70°C to +15°C</p> <p>Atmospheric Pressure: 480 mBar minimum (approx 5000m above sea level)</p>
Cooling:	Ventilation:	Forced Air, 150 CFM (70.79 L/Sec), intake at sides, exhaust at rear panel. Observe specified panel clearances and mounting instructions
	Coolant Water:	<p>Flow: 2.0 gallons/minute (7.57 L/min) minimum.</p> <p>Inlet Temperature: +15°C minimum to +40°C maximum temperature, +22°C to +28°C recommended.</p> <p>Pressure: 70 PSI (482.63 kPa) maximum</p>
	Coolant Water Purity:	<p>pH: Between 7 and 9</p> <p>Total Chlorine: <20ppm</p> <p>Total Nitrate: <10ppm</p> <p>Total Sulfate: <100ppm</p> <p>Total Dissolved Solids: <250ppm</p> <p>Total Hardness expressed as Calcium Carbonate equivalent: <250ppm</p> <p>Specific Resistivity: >2500 Ohms/cm @ +25°C</p>
	Coolant Water Fittings:	Type 3/8" N.P.T. Female threaded pipe
	Coolant Water Supply Line Inside Diameter:	3/8" [9.52mm] Inside Diameter (I.D.) or larger.

R5001 Specifications - 4U Package (Part Number Series 960096XXXX)

Waste Heat into Coolant Water	3000 Watts maximum. (170.6 BTU/min) Note: The waste heat does not peak at 5000 Watts of output power - the waste heat peaks at 50% to 80% of full power or under certain reflected power conditions.
Interlocks:	<p>External: External interlock provided for disabling RF output power.</p> <p>Valve: Prevents/disables RF Power output if external water valve is missing or un plugged.</p> <p>Water Flow: Internal sensor prevents/disables RF output if coolant water flow is insufficient.</p> <p>RF Output Connector: Paddle-Type interlock disables RF output if a RF cable is not connected to the RF output connector or is removed from the RF output connector.</p>
Interface Connections:	<p>Analog Interface: 25 pin Female D-Sub Connector</p> <p>Serial Interface: 9 pin Female D-Sub Connector</p> <p>CEX Input: Female type BNC connector, 3 to 8V Peak-to-Peak sine wave, Ohms Nominal Impedance at specified operating frequency.</p> <p>CEX Output: Female type BNC connector, 5 to 8V Peak-to-Peak into 50 Ohms at specified operating frequency.</p> <p>VALVE: 4-Pin Male Disk-Drive Connector</p>
Power Monitor Scaling:	<p>Forward Power Monitor: Monitor output is linearly proportional to 0 to 5000 Watts of forward power. Output scaling is 5.0VDC at 5000 Watts (1.0mV/Watt) or 10.0VDC at 5000 Watts (2.0mV/Watt), depending on the analog voltage range selected. (Default scaling)</p> <p>Reflected Power Monitor: Monitor output is linearly proportional to 0 to 500 Watts of reflected power. Output scaling is 5.0VDC at 500 Watts (10mV/Watt) or 10.0VDC at 500 Watts (20mV/Watt), depending on the analog voltage range selected. (Default scaling)</p>

R5001 Specifications - 4U Package (Part Number Series 960096XXXX)

Analog Setpoint Sensitivity: In Power Control mode, analog setpoint sensitivity is 5000 Watts at 5.0VDC (1.0mV per Watt) or 5000 Watts at 10.0VDC (2.0mV per Watt), depending on the analog voltage range selected.

Labels: Safety: Per customer requirements. Labels may include Hazardous Voltage, Heavy Object
Identification: Seren IPS Inc. part number, serial number, and customer part number (optional), RF output frequency

Battery: Internal, 3V 255mAh, 23mm Coin Style, Type BR2330 or CR2330 (For retention of user-configurable settings)

Supplied Accessories: Solenoid Water Valve
Product Information CD-ROM

Dimensions inch (mm): 7.00 (177.80) High x 19.00 (482.60) Wide x 25.63 (651.00) Deep.
Width includes Rack Mounting Brackets.
Width without Rack Mounting Brackets: 17.00 (431.80)
Depth includes Mains Power Connection Terminal Box

Weight: 70 Lbs (36.28Kg)

R5001 Specifications - 5U Package

(Part Number Series 960072XXXX and 960086XXXX)

AC Mains	Available Options, specify at time of order:	
Input Power	1. Nominal Voltage Rating: 208-240V, Three-Phase 4-Wire Delta Operating Voltage Range: 190-264V, Three Phase 4-Wire Delta 2. Nominal Voltage Rating: 380-415V, Three Phase 5-Wire Wye Operating Voltage Range: 342-457V, Three Phase 5-Wire Wye There are no transformer voltage taps to configure. Input power is not field-configurable.	
	Frequency:	47-63 HZ
	Current (FLA):	208-240V Three Phase 4-Wire Delta: 30A Per Phase Maximum 380-415V Three-Phase 5-Wire Wye: 25A Per Phase Maximum
	Power required:	9506VA Maximum
	Over-current Protection:	Rear Panel Circuit Breaker, 2x 1.5A 1/4"x1-1/4" time-delay fuses.
	Short Circuit Current Rating (SCCR)	10KA
	Note: For SEMI S2 compliance, the system power distribution panel or system integrator must supply an over-current protection device (fuse or circuit breaker) with a minimum interrupting capacity of 10,000A (10,000AIC).	
Power Cord and Power Plug:	208-240V Three Phase 4-Wire Delta: 380-415V Three-Phase 5-Wire Wye:	Cord: Captive, 10 AWG, 4 Conductor, Type SOW, 6 foot (1.82m) length. Plug: NEMA Type L15-30P locking connector Cord: Captive, 12AWG, 5 Conductor, Type S00W, 10 foot (3.05m) length. Plug: None Supplied. The installer is responsible for connecting and/or terminating the power cord in accordance with applicable national and local codes.

R5001 Specifications - 5U Package

(Part Number Series 960072XXXX and 960086XXXX)

Output:	Power:	0 to 5000 Watts into 50 Ohms
	Maximum Reflected Power:	500 Watts
	Frequency:	Frequency Synthesized P/N 960072XXXX Series: 13.56MHz Fixed standard. Optional Frequencies (Specify at time of order): 27.12MHz Fixed and 1.7-2.1MHz Variable (1 KHz Steps). P/N 960086XXXX Series: 40.68MHz Fixed
	Leveling:	Forward Power, Load (Net) Power, External Feedback (RF or DC Probe)
	RF Output Connector:	Type 7/16 DIN, or LC female. Customer Specified
	Power Stability:	0.5% Long Term, +/- 1 Watt
	Output Impedance:	50 Ohms, +/-5 Ohms Nominal
	Metering Accuracy: (Forward Power)	+/- 2% of Reading, +/- 1 Watt
	Temperature Coefficient:	0.25% per °C
	Forward Power Regulation:	+/- 1% into 50 Ohms
	Load Tolerance:	No oscillation or failure into a mismatch condition.
	Protection:	Forward power limits on current, transistor power dissipation, and excessive reflected power. Unit is short-circuit and open-circuit protected. Unit is thermally protected.
	Spurious Radiation:	Designed to meet or exceed FCC requirements.
	Harmonics:	-50dBc
	Noise, Hum, and Ripple:	-50dBc
	Pulsing:	20Hz to 10KHz, 1-Hz Steps; 0 to 100% duty cycle; 50 micro-second minimum pulse

R5001 Specifications - 5U Package

(Part Number Series 960072XXXX and 960086XXXX)

Environment:	Operating:	<p>Ambient Temperature: +5°C to +40°C</p> <p>Relative Humidity: 10% to 90% non-condensing, non-icing</p> <p>Atmospheric Pressure: 683 mBar minimum (approx 3000m above sea level)</p> <p>Pollution Degree: 2 or cleaner.</p>
	Storage:	<p>Ambient Temperature: -25°C to +55°C</p> <p>Relative Humidity: 5% to 95%, non-condensing</p> <p>Atmospheric Pressure: 585 mBar minimum (approx 4000m above sea level)</p>
	Transportation:	<p>Ambient Temperature: -25°C to +70°C</p> <p>Relative Humidity: 95% Maximum absolute humidity when unit temperature directly decreases from +70°C to +15°C</p> <p>Atmospheric Pressure: 480 mBar minimum (approx 5000m above sea level)</p>
Cooling:	Ventilation:	<p>Forced Air, 150 CFM (70.79 L/Sec), intake at sides, exhaust at rear panel. Observe specified panel clearances and mounting instructions</p>
	Coolant Water:	<p>Flow: 2.0 gallons/minute (7.57 L/min) minimum.</p> <p>Inlet Temperature: +15°C minimum to +40°C maximum temperature, +22°C to +28°C recommended.</p> <p>Pressure: 70 PSI (482.63 kPa) maximum</p>
	Coolant Water Purity:	<p>pH: Between 7 and 9</p> <p>Total Chlorine: <20ppm</p> <p>Total Nitrate: <10ppm</p> <p>Total Sulfate: <100ppm</p> <p>Total Dissolved Solids: <250ppm</p> <p>Total Hardness expressed as Calcium Carbonate equivalent: <250ppm</p> <p>Specific Resistivity: >2500 Ohms/cm @ +25°C</p>
	Coolant Water Fittings:	<p>Type 3/8" N.P.T. Female threaded pipe</p>

R5001 Specifications - 5U Package

(Part Number Series 960072XXXX and 960086XXXX)

Coolant Water Supply Line Inside Diameter:	3/8" [9.52mm] Inside Diameter (I.D.) or larger.
Waste Heat into Coolant Water	3000 Watts maximum. (170.6 BTU/min) Note: The waste heat does not peak at 5000 Watts of output power - the waste heat peaks at 50% to 80% of full power or under certain reflected power conditions.
Interlocks:	<p>External: External interlock provided for disabling RF output power</p> <p>Valve (optional): Prevents/disables RF Power output if external water valve is missing or un plugged. (standard units ignore this interlock – consult factory if valve interlock is required)</p>
Interface Connections:	<p>Analog Interface: 25 pin Female D-Sub Connector</p> <p>Serial Interface: 9 pin Female D-Sub Connector</p> <p>CEX Input: Female type BNC connector, 3 to 8V Peak-to-Peak sine wave, 50 Ohms Nominal Impedance at specified operating frequency.</p> <p>CEX Output: Female type BNC connector, 5 to 8V Peak-to-Peak into 50 Ohms at specified operating frequency.</p> <p>VALVE 4-Pin Male Disk-Drive Connector</p>
Power Monitor Scaling:	<p>Forward Power Monitor Monitor output is linearly proportional to 0 to 5000 Watts of forward power.</p> <p>Output scaling is 5.0VDC at 5000 Watts (1.0mV/Watt) or 10.0VDC at 5000 Watts (2.0mV/Watt), depending on the analog voltage range selected. (Default scaling)</p>

R5001 Specifications - 5U Package

(Part Number Series 960072XXXX and 960086XXXX)

	Reflected Power Monitor	Monitor output is linearly proportional to 0 to 500 Watts of reflected power. Output scaling is 5.0VDC at 500 Watts (10mV/Watt) or 10.0VDC at 500 Watts (20mV/Watt), depending on the analog voltage range selected. (Default scaling)
Analog Setpoint Sensitivity:		In Power Control mode, analog setpoint sensitivity is 5000 Watts at 5.0VDC (1.0mV per Watt) or 5000 Watts at 10.0VDC (2.0mV per Watt), depending on the analog voltage range selected.
Labels:	Safety:	Per customer requirements. Labels may include Hazardous Voltage, Heavy Object
	Identification:	Seren IPS Inc. part number, serial number, and customer part number (optional), RF output frequency
Battery:		Internal, 3V 255mAh, 23mm Coin Style, Type BR2330 or CR2330 (For retention of user-configurable settings)
Supplied Accessories:		Solenoid Water Valve Product Information CD-ROM
Dimensions inch (mm):		8.75 (222.25) High x 19.00 (482.60) Wide x 26.63 (676.40) Deep. Width includes Rack Mounting Brackets. Width without Rack Mounting Brackets: 17.00 (431.80) Depth includes Mains Power Connection Terminal Box
Weight:		80 Lbs (36.28Kg)

L5001 Specifications - 5U Package

AC Mains Input Power	Available Options, specify at time of order:	
	1. Nominal Voltage Rating: 208-240V, Three-Phase 4-Wire Delta Operating Voltage Range: 190-264V, Three Phase 4-Wire Delta 2. Nominal Voltage Rating: 380-415V, Three Phase 5-Wire Wye Operating Voltage Range: 342-457V, Three Phase 5-Wire Wye There are no transformer voltage taps to configure. Input power is not field-configurable.	
	Frequency:	47-63 HZ
	Current (FLA):	208-240V Three Phase 4-Wire Delta: 30A Per Phase Maximum 380-415V Three-Phase 5-Wire Wye: 25A Per Phase Maximum
	Power required:	9506VA Maximum
	Over-current Protection:	Rear Panel Circuit Breaker, 2x 1.5A 1/4"x1-1/4" time-delay fuses.
	Short Circuit Current Rating (SCCR)	10KA
	Note: For SEMI S2 compliance, the system power distribution panel or system integrator must supply an over-current protection device (fuse or circuit breaker) with a minimum interrupting capacity of 10,000A (10,000AIC).	
Power Cord and Power Plug:	208-240V Three Phase 4-Wire Delta:	Cord: Captive, 10 AWG, 4 Conductor, Type SOW, 6 foot (1.82m) length . Plug: NEMA Type L15-30P locking connector
	380-415V Three-Phase 5-Wire Wye:	Cord: Captive, 12AWG, 5 Conductor, Type SOOW, 10 foot (3.05m) length. Plug: None Supplied. The installer is responsible for connecting and/or terminating the power cord in accordance with applicable national and local codes.

L5001 Specifications - 5U Package

Output:	Power:	0 to 5000 Watts into 50 Ohms
	Maximum Reflected Power:	500 Watts
	Frequency:	350KHz to 460KHz, variable, 1 KHz steps, frequency synthesized. Other frequency ranges available; consult the factory or local Seren IPS sales representative.
	Leveling:	Forward Power, Load (Net) Power, External Feedback (RF or DC Probe)
	RF Output Connector:	Type 7/16 DIN, or LC female. Specify at time of order.
	Power Stability:	0.5% Long Term, +/- 1 Watt
	Output Impedance:	50 Ohms, +/-5 Ohms Nominal
	Metering Accuracy: (Forward Power)	+/- 2% of Reading, +/- 1 Watt
	Temperature Coefficient:	0.25% per °C
	Forward Power Regulation:	+/- 1% into 50 Ohms
	Load Tolerance:	No oscillation or failure into a mismatch condition.
	Protection:	Forward power limits on current, transistor power dissipation, and excessive reflected power. Unit is short-circuit and open-circuit protected. Unit is thermally protected.
	Spurious Radiation:	Designed to meet or exceed FCC requirements.
	Harmonics:	Equal to or less than -40dBc at maximum output frequency
	Noise, Hum, and Ripple:	Equal to or less than -50dBc
	Pulsing:	20Hz to 10KHz, 1-Hz Steps; 0 to 100% duty cycle; 50 micro-second minimum pulse

L5001 Specifications - 5U Package

Environment:	Operating:	<p>Ambient Temperature: +5°C to +40°C</p> <p>Relative Humidity: 10% to 90% non-condensing, non-icing</p> <p>Atmospheric Pressure: 683 mBar minimum (approx 3000m above sea level)</p> <p>Pollution Degree: 2 or cleaner.</p>
	Storage:	<p>Ambient Temperature: -25°C to +55°C</p> <p>Relative Humidity: 5% to 95%, non-condensing</p> <p>Atmospheric Pressure: 585 mBar minimum (approx 4000m above sea level)</p>
	Transportation:	<p>Ambient Temperature: -25°C to +70°C</p> <p>Relative Humidity: 95% Maximum absolute humidity when unit temperature directly decreases from +70°C to +15°C</p> <p>Atmospheric Pressure: 480 mBar minimum (approx 5000m above sea level)</p>
Cooling:	Ventilation:	Forced Air, 150 CFM (70.79 L/Sec), intake at sides, exhaust at rear panel. Observe specified panel clearances and mounting instructions
	Coolant Water:	<p>Flow: 2.0 gallons/minute (7.57 L/min) minimum.</p> <p>Inlet Temperature: +15°C minimum to +40°C maximum temperature, +22°C to +28°C recommended.</p> <p>Pressure: 70 PSI (482.63 kPa) maximum</p>
	Coolant Water Purity:	<p>pH: Between 7 and 9</p> <p>Total Chlorine: <20ppm</p> <p>Total Nitrate: <10ppm</p> <p>Total Sulfate: <100ppm</p> <p>Total Dissolved Solids: <250ppm</p> <p>Total Hardness expressed as Calcium Carbonate equivalent: <250ppm</p> <p>Specific Resistivity: >2500 Ohms/cm @ +25°C</p>
	Coolant Water Fittings:	Type 3/8" N.P.T. Female threaded pipe
	Coolant Water Supply Line Inside Diameter:	3/8" [9.52mm] Inside Diameter (I.D.) or larger.

L5001 Specifications - 5U Package

	Waste Heat into Coolant Water	3000 Watts maximum. (170.6 BTU/min) Note: The waste heat does not peak at 5000 Watts of output power - the waste heat peaks at 50% to 80% of full power or under certain reflected power conditions.
Interlocks:	External:	External interlock provided for disabling RF output power
	Valve (optional):	Prevents/disables RF Power output if external water valve is missing or un-plugged. (standard units ignore this interlock – consult factory if valve interlock is required)
Interface Connections:	Analog Interface:	25 pin Female D-Sub Connector
	Serial Interface:	9 pin Female D-Sub Connector
	CEX Input:	Female type BNC connector, 3 to 8V Peak-to-Peak sine wave, 50 Ohms Nominal Impedance at specified operating frequency.
	CEX Output:	Female type BNC connector, 5 to 8V Peak-to-Peak into 50 Ohms at specified operating frequency.
	VALVE	4-Pin Male Disk-Drive Connector
Power Monitor Scaling:	Forward Power Monitor	Monitor output is linearly proportional to 0 to 5000 Watts of forward power. Output scaling is 5.0VDC at 5000 Watts (1.0mV/Watt) or 10.0VDC at 5000 Watts (2.0mV/Watt), depending on the analog voltage range selected. (Default scaling)
	Reflected Power Monitor	Monitor output is linearly proportional to 0 to 500 Watts of reflected power. Output scaling is 5.0VDC at 500 Watts (10mV/Watt) or 10.0VDC at 500 Watts (20mV/Watt), depending on the analog voltage range selected. (Default scaling)

L5001 Specifications - 5U Package

Analog Setpoint Sensitivity:	In Power Control mode, analog setpoint sensitivity is 5000 Watts at 5.0VDC (1.0mV per Watt) or 5000 Watts at 10.0VDC (2.0mV per Watt), depending on the analog voltage range selected.	
Labels:	Safety:	Per customer requirements. Labels may include Hazardous Voltage, Heavy Object
	Identification:	Seren IPS Inc. part number, serial number, and customer part number (optional), RF output frequency
Battery:	Internal, 3V 255mAh, 23mm Coin Style, Type BR2330 or CR2330 (For retention of user-configurable settings)	
Supplied Accessories:	Solenoid Water Valve Product Information CD-ROM	
Dimensions inch (mm):	8.75 (222.25) High x 19.00 (482.60) Wide x 26.63 (676.40) Deep. Width includes Rack Mounting Brackets. Width without Rack Mounting Brackets: 17.00 (431.80) Depth includes Mains Power Connection Terminal Box	
Weight:	80 Lbs (36.28Kg)	

R10001 (27MHz 8KW OEM version only) Specifications

Part Number 9600780001 Only

AC Mains Input Power	Nominal Rated Voltage: 200-240V Three Phase 4-Wire Delta Operating Voltage Range: 180-264V Three Phase 4-Wire Delta There are no transformer voltage taps to configure. Input power is not field-configurable.	
	Frequency:	47-63 HZ
	Current (FLA):	65A Per Phase Maximum
	Power required:	19300VA Maximum
	Over-current Protection:	Rear Panel Circuit Breaker
	Short Circuit Current Rating (SCCR)	10KA
	Note: For SEMI S2 compliance, the system power distribution panel or system integrator must supply an over-current protection device (fuse or circuit breaker) with a minimum interrupting capacity of 10,000A (10,000AIC)	
Power Cord:	12 foot (3.66m) Length	Captive, 6 AWG (16mm ²), Stranded 4-Conductor 500V IEC 60227, IEC 60228, or IEC 60245 approved. Lapp Group / Olflex Series 110 No. 1119624 or equivalent.
Power Plug:	None Provided	The installer is responsible for connecting and/or terminating the power cord in accordance with applicable national and local codes.
Output:	Power:	0 to 8000 Watts into 50 Ohms
	Maximum Reflected Power:	800 Watts
	Frequency:	27.12MHz, Fixed, Frequency Synthesized
	Leveling:	Forward Power, Load (Net) Power, External Feedback (RF or DC Probe)
	RF Output Connector:	Type LC or 7/16 DIN female. Customer Specified at time of order.

R10001 (27MHz 8KW OEM version only) Specifications

Part Number 9600780001 Only

Power Stability:	0.5% Long Term, +/- 1 Watt
Output Impedance:	50 Ohms, +/-5 Ohms Nominal
Metering Accuracy: (Forward Power)	+/- 2% of Reading, +/- 1 Watt
Temperature Coefficient:	0.25% per °C
Forward Power Regulation:	+/- 1% into 50 Ohms
Load Tolerance:	No oscillation or failure into a mismatch condition.
Protection:	Forward power limits on current, transistor power dissipation, and excessive reflected power. Unit is short-circuit and open-circuit protected. Unit is thermally protected.
Spurious Radiation:	Designed to meet or exceed FCC requirements.
Harmonics:	-50dBc
Noise, Hum, and Ripple:	-50dBc
Pulsing:	20Hz to 10KHz, 1-Hz Steps; 0 to 100% duty cycle, 50 micro-second minimum pulse
Environment: Operating:	Ambient Temperature: +5°C to +40°C Relative Humidity: 10% to 90% non-condensing, non-icing Atmospheric Pressure: 683 mBar minimum (approx 3000m above sea level) Pollution Degree: 2 or cleaner.
Storage:	Ambient Temperature: -25°C to +55°C Relative Humidity: 5% to 95%, non-condensing Atmospheric Pressure: 585 mBar minimum (approx 4000m above sea level)

R10001 (27MHz 8KW OEM version only) Specifications

Part Number 9600780001 Only

Transportation:	<p>Ambient Temperature: -25°C to +70°C</p> <p>Relative Humidity: 95% Maximum absolute humidity when unit temperature directly decreases from +70°C to +15°C</p> <p>Atmospheric Pressure: 480 mBar minimum (approx 5000m above sea level)</p>
Cooling:	<p>Ventilation: Forced Air, 235 CFM (110.90 L/Sec), intake at front and sides, exhaust at rear panel. Observe specified panel clearances and mounting instructions</p> <p>Coolant Water: Flow: 2.0 gallons/minute (7.57 L/min) minimum. Inlet Temperature: +15°C minimum to +40°C maximum temperature, +22°C to +28°C recommended. Pressure: 70 PSI (482.63 kPa) maximum</p> <p>Coolant Water Purity: pH: Between 7 and 9 Total Chlorine: <20ppm Total Nitrate: <10ppm Total Sulfate: <100ppm Total Dissolved Solids: <250ppm Total Hardness expressed as Calcium Carbonate equivalent: <250ppm Specific Resistivity: >2500 Ohms/cm @ +25°C</p> <p>Coolant Water Fittings: Type 3/8" N.P.T. Female threaded pipe</p> <p>Coolant Water Supply Line Inside Diameter: 3/8" [9.52mm] Inside Diameter (I.D.) or larger.</p> <p>Waste Heat into Coolant Water 7000 Watts (398 BTU/minute) maximum. Note: The waste heat does not peak at 8000 Watts of output power - the waste heat peaks at 50% to 80% of full power or under certain reflected power conditions.</p>

R10001 (27MHz 8KW OEM version only) Specifications

Part Number 9600780001 Only

Interlocks:	External:	External interlock provided for disabling RF output power
	Valve: (Optional on units manufactured before April 1, 2009)	Prevents/disables RF Power output if external water valve is missing or unplugged. (standard units ignore this interlock – consult factory if valve interlock is required)
	Water Flow: (Standard on units manufactured April 1, 2009 and later)	Prevents/disables RF Power output if external water valve assembly is missing or unplugged. Prevents/disables RF power output if coolant water flow is insufficient.
Interface Connections:	Analog Interface:	25 pin Female D-Sub Connector
	Serial Interface:	9 pin Female D-Sub Connector
	CEX Input:	Female type BNC connector, 3 to 8V Peak-to-Peak sine wave, 27.12MHz, 50 Ohms Nominal Impedance
	CEX Output:	Female type BNC connector, 5 to 8V Peak-to-Peak, 27.12MHz, into 50 Ohms
	VALVE	4-Pin Male Disk-Drive Connector
Power Monitor Scaling:	Forward Power Monitor	Monitor output is linearly proportional to 0 to 8000 Watts of forward power. Output scaling is 5.0VDC at 8000 Watts (0.625mV/Watt) or 10.0VDC at 8000 Watts (1.25mV/Watt), depending on the analog voltage range selected. (Default scaling)
	Reflected Power Monitor	Monitor output is linearly proportional to 0 to 800 Watts of reflected power. Output scaling is 5.0VDC at 800 Watts (6.25mV/Watt) or 10.0VDC at 800 Watts (12.5mV/Watt), depending on the analog voltage range selected. (Default scaling)
Analog Setpoint Sensitivity:	In Power Control mode, analog setpoint sensitivity is 8000 Watts at 5.0VDC (0.625mV per Watt) or 8000 Watts at 10.0VDC (1.25mV per Watt), depending on the analog voltage range selected.	

R10001 (27MHz 8KW OEM version only) Specifications

Part Number 9600780001 Only

Labels:	Safety:	Per customer requirements. Labels may include Hazardous Voltage, Heavy Object
	Identification:	Seren IPS Inc. part number, serial number, and customer part number (optional), RF output frequency
Battery:	Internal, 3V 255mAh, 23mm Coin Style, Type BR2330 or CR2330 (For retention of user-configurable settings)	
Supplied Accessories:	Solenoid Water Valve with water flow sensor Product Information CD-ROM	
Dimensions inch (mm):	10.50 (266.70) High x 19.00 (482.60) Wide x 33.12 (841.25) Deep. Width includes Rack Mounting Brackets. Width without Rack Mounting Brackets: 17.00 (431.80) Depth includes Mains Power Connection Terminal Box	
Weight:	162.5 Lbs (73.70Kg)	

R10001 Specifications

AC Mains Input Power	Available Options, specify at time of order:	
	1. Nominal Voltage Rating: 200-240V, Three-Phase 4-Wire Delta Operating Voltage Range: 180-264V, Three Phase 4-Wire Delta 2. Nominal Voltage Rating: 380-415V, Three Phase 5-Wire Wye Operating Voltage Range: 342-457V, Three Phase 5-Wire Wye There are no transformer voltage taps to configure. Input power is not field-configurable.	
	Frequency:	47-63 HZ
	Current (FLA):	200-240V Three Phase 4-Wire Delta: 65A Per Phase Maximum 380-415V Three Phase 5-Wire Wye: 40A Per Phase Maximum
	Power required:	19300VA Maximum
	Over-current Protection:	Rear Panel Circuit Breaker
	Short Circuit Current Rating (SCCR)	10KA
	Note: For SEMI S2 compliance, the system power distribution panel or system integrator must supply an over-current protection device (fuse or circuit breaker) with a minimum interrupting capacity of 10,000A (10,000AIC)	
Power Cord:	200-240V Three Phase 4-Wire Delta:	Captive, 6AWG (16mm ²), Stranded 4-Conductor, 500V IEC 60227, IEC 60228, or IEC 60245 approved. Lapp Group / Olflex Series 110 No. 1119624 or equivalent. 12 foot (3.66m) length
	380-415V Three Phase 5-Wire Wye:	Captive, 6AWG (16mm ²), Stranded 5-Conductor, 500V IEC 60227, IEC 60228, or IEC 60245 approved. 12 foot (3.66m) length
Power Plug:	None Provided	The installer is responsible for connecting and/or terminating the power cord in accordance with applicable national and local codes.

R10001 Specifications

Output:	Power:	0 to 10000 Watts into 50 Ohms
	Maximum Reflected Power:	800 Watts
	Frequency:	Fixed, Frequency Synthesized, 13.56MHz standard. 27.12MHz and 40.68MHz options available (specify at time of order).
	Leveling:	Forward Power, Load (Net) Power, External Feedback (RF or DC Probe)
	RF Output Connector:	Type LC or 7/16 DIN female. Specify at time of order.
	Power Stability:	0.5% Long Term, +/- 1 Watt
	Output Impedance:	50 Ohms, +/-5 Ohms Nominal
	Metering Accuracy: (Forward Power)	+/- 2% of Reading, +/- 1 Watt
	Temperature Coefficient:	0.25% per °C
	Forward Power Regulation:	+/- 1% into 50 Ohms
	Load Tolerance:	No oscillation or failure into a mismatch condition.
	Protection:	Forward power limits on current, transistor power dissipation, and excessive reflected power. Unit is short-circuit and open-circuit protected. Unit is thermally protected.
	Spurious Radiation:	Designed to meet or exceed FCC requirements.
	Harmonics:	-50dBc
	Noise, Hum, and Ripple:	-50dBc
	Pulsing:	20Hz to 10KHz, 1-Hz Steps; 0 to 100% duty cycle, 50 micro-second minimum pulse

R10001 Specifications

Environment:	Operating:	<p>Ambient Temperature: +5°C to +40°C</p> <p>Relative Humidity: 10% to 90% non-condensing, non-icing</p> <p>Atmospheric Pressure: 683 mBar minimum (approx 3000m above sea level)</p> <p>Pollution Degree: 2 or cleaner.</p>
	Storage:	<p>Ambient Temperature: -25°C to +55°C</p> <p>Relative Humidity: 5% to 95%, non-condensing</p> <p>Atmospheric Pressure: 585 mBar minimum (approx 4000m above sea level)</p>
	Transportation:	<p>Ambient Temperature: -25°C to +70°C</p> <p>Relative Humidity: 95% Maximum absolute humidity when unit temperature directly decreases from +70°C to +15°C</p> <p>Atmospheric Pressure: 480 mBar minimum (approx 5000m above sea level)</p>
Cooling:	Ventilation:	<p>Forced Air, 235 CFM (110.90 L/Sec), intake at front and sides, exhaust at rear panel. Observe specified panel clearances and mounting instructions</p>
	Coolant Water:	<p>Flow: 2.0 gallons/minute (7.57 L/min) minimum.</p> <p>Inlet Temperature: +15°C minimum to +40°C maximum temperature, +22°C to +28°C recommended.</p> <p>Pressure: 70 PSI (482.63 kPa) maximum</p>
	Coolant Water Purity:	<p>pH: Between 7 and 9</p> <p>Total Chlorine: <20ppm</p> <p>Total Nitrate: <10ppm</p> <p>Total Sulfate: <100ppm</p> <p>Total Dissolved Solids: <250ppm</p> <p>Total Hardness expressed as Calcium Carbonate equivalent: <250ppm</p> <p>Specific Resistivity: >2500 Ohms/cm @ +25°C</p>
	Coolant Water Fittings:	<p>Type 3/8" N.P.T. Female threaded pipe</p>

R10001 Specifications

Coolant Water Supply Line Inside Diameter:	3/8" [9.52mm] Inside Diameter (I.D.) or larger.
Waste Heat into Coolant Water	8000 Watts (455 BTU/minute) maximum. Note: The waste heat does not peak at 10000 Watts of output power - the waste heat peaks at 50% to 80% of full power or under certain reflected power conditions.
Interlocks:	<p>External: External interlock provided for disabling RF output power</p> <p>Valve: Prevents/disables RF Power output if external water valve is missing or unplugged. (standard units ignore this interlock – consult factory if valve interlock is required) (Optional on units manufactured before April 1, 2009)</p> <p>Water Flow: Prevents/disables RF Power output if external water valve assembly is missing or unplugged. Prevents/disables RF power output if coolant water flow is insufficient. (Standard on units manufactured April 1, 2009 and later)</p>
Interface Connections:	<p>Analog Interface: 25 pin Female D-Sub Connector</p> <p>Serial Interface: 9 pin Female D-Sub Connector</p> <p>CEX Input: Female type BNC connector, 3 to 8V Peak-to-Peak sine wave, 50 Ohms Nominal Impedance at specified operating frequency.</p> <p>CEX Output: Female type BNC connector, 5 to 8V Peak-to-Peak, into 50 Ohms at specified operating frequency.</p> <p>VALVE 4-Pin Male Disk-Drive Connector</p>
Power Monitor Scaling:	<p>Forward Power Monitor Monitor output is linearly proportional to 0 to 10000 Watts of forward power.</p> <p>Output scaling is 5.0VDC at 10000 Watts (0.5mV/Watt) or 10.0VDC at 10000 Watts (1.0mV/Watt), depending on the analog voltage range selected. (Default scaling)</p>

R10001 Specifications

Reflected Power Monitor	Monitor output is linearly proportional to 0 to 1000 Watts of reflected power. Output scaling is 5.0VDC at 1000 Watts (5mV/Watt) or 10.0VDC at 1000 Watts (10mV/Watt), depending on the analog voltage range selected. (Default scaling)				
Analog Setpoint Sensitivity:	In Power Control mode, analog setpoint sensitivity is 10000 Watts at 5.0VDC (0.5mV per Watt) or 10000 Watts at 10.0VDC (1.0mV per Watt), depending on the analog voltage range selected.				
Battery	Internal, 3V 255mAh, 23mm Coin Style, Type BR2330 or CR2330 (For retention of user-configurable settings)				
Supplied Accessories:	Solenoid Water Valve with water flow sensor Product Information CD-ROM				
Labels:	<table border="0" style="width: 100%;"> <tr> <td style="vertical-align: top;">Safety:</td> <td>Per customer requirements. Labels may include Hazardous Voltage, Heavy Object</td> </tr> <tr> <td style="vertical-align: top;">Identification:</td> <td>Seren IPS Inc. part number, serial number, and customer part number (optional), RF output frequency</td> </tr> </table>	Safety:	Per customer requirements. Labels may include Hazardous Voltage, Heavy Object	Identification:	Seren IPS Inc. part number, serial number, and customer part number (optional), RF output frequency
Safety:	Per customer requirements. Labels may include Hazardous Voltage, Heavy Object				
Identification:	Seren IPS Inc. part number, serial number, and customer part number (optional), RF output frequency				
Dimensions inch (mm):	10.50 (266.70) High x 19.00 (482.60) Wide x 33.12 (841.25) Deep. Width includes Rack Mounting Brackets. Width without Rack Mounting Brackets: 17.00 (431.80) Depth includes Mains Power Connection Terminal Box				
Weight:	162.5Lbs (73.70Kg)				

R15001 Specifications

AC Mains Input Power	Available Options, specify at time of order:	
	1. Nominal Voltage Rating: 200-240V, Three-Phase 4-Wire Delta Operating Voltage Range: 180-264V, Three Phase 4-Wire Delta	
	2. Nominal Voltage Rating: 380-415V, Three Phase 5-Wire Wye Operating Voltage Range: 342-457V, Three Phase 5-Wire Wye	
	There are no transformer voltage taps to configure. Input power is not field-configurable.	
	Frequency:	47-63 HZ
	Current (FLA):	200-240V Three Phase 4-Wire Delta: 85A Per Phase Maximum
		380-415V Three Phase 5-Wire Wye: 40A Per Phase Maximum
	Power required:	24400VA Maximum
	Over-current Protection:	Rear Panel Circuit Breaker.
	Short Circuit Current Rating (SCCR)	10KA
	Note: For SEMI S2 compliance, the system power distribution panel or system integrator must supply an over-current protection device (fuse or circuit breaker) with a minimum interrupting capacity of 10,000A (10,000AIC)	
Power Cord:	200-240V 3-Phase 4-Wire Delta:	Captive, 6 AWG (16mm ²), Stranded 4-Conductor 500V IEC 60227, IEC 60228, or IEC 60245 approved. Lapp Group / Olflex Series 110 No. 1119624 or equivalent. 12 foot (3.66m) length.
	380-415V 3-Phase 5-Wire Wye:	Captive, 6 AWG (16mm ²), Stranded 4-Conductor 500V IEC 60227, IEC 60228, or IEC 60245 approved. 12 foot (3.66m) length.
Power Plug:	None supplied	The installer is responsible for connecting and/or terminating the power cord in accordance with applicable national and local codes.

R15001 Specifications

Output:	Power:	0 to 15000 Watts into 50 Ohms
	Maximum Reflected Power:	800 Watts
	Frequency:	13.56MHz, Fixed, Frequency Synthesized
	Leveling:	Forward Power, Load (Net) Power, External Feedback (RF or DC Probe)
	RF Output Connector:	Type 1-5/8" EIA Flange.
	Power Stability:	0.5% Long Term, +/- 1 Watt
	Output Impedance:	50 Ohms, +/-5 Ohms Nominal
	Metering Accuracy: (Forward Power)	+/- 2% of Reading, +/- 1 Watt
	Temperature Coefficient:	0.25% per °C
	Forward Power Regulation:	+/- 1% into 50 Ohms
	Load Tolerance:	No oscillation or failure into a mismatch condition.
	Protection:	Forward power limits on current, transistor power dissipation, and excessive reflected power. Unit is short-circuit and open-circuit protected. Unit is thermally protected.
	Spurious Radiation:	Designed to meet or exceed FCC requirements.
	Harmonics:	-50dBc
	Noise, Hum, and Ripple:	-50dBc
	Pulsing:	20Hz to 10KHz, 1-Hz Steps; 0 to 100% duty cycle, 50 micro-second minimum pulse
Environment:	Operating:	Ambient Temperature: +5°C to +40°C Relative Humidity: 10% to 90% non-condensing, non-icing Atmospheric Pressure: 683 mBar minimum (approx 3000m above sea level) Pollution Degree: 2 or cleaner.

R15001 Specifications

Storage:	Ambient Temperature: -25°C to +55°C Relative Humidity: 5% to 95%, non-condensing Atmospheric Pressure: 585 mBar minimum (approx 4000m above sea level)
Transportation:	Ambient Temperature: -25°C to +70°C Relative Humidity: 95% Maximum absolute humidity when unit temperature directly decreases from +70°C to +15°C Atmospheric Pressure: 480 mBar minimum (approx 5000m above sea level)
Cooling:	Ventilation: Forced Air, 235 CFM (110.90 L/Sec), intake at front and sides, exhaust at rear panel. Observe specified panel clearances and mounting instructions
Coolant Water:	Flow: 2.0 gallons/minute (7.57 L/min) minimum. Inlet Temperature: +15°C minimum to +40°C maximum temperature, +22°C to +28°C recommended. Pressure: 70 PSI (482.63 kPa) maximum
Coolant Water Purity:	pH: Between 7 and 9 Total Chlorine: <20ppm Total Nitrate: <10ppm Total Sulfate: <100ppm Total Dissolved Solids: <250ppm Total Hardness expressed as Calcium Carbonate equivalent: <250ppm Specific Resistivity: >2500 Ohms/cm @ +25°C
Coolant Water Fittings:	Type 3/8" N.P.T. Female threaded pipe
Coolant Water Supply Line Inside Diameter:	3/8" [9.52mm] Inside Diameter (I.D.) or larger.
Waste Heat into Coolant Water	8000 Watts (455 BTU/minute) maximum. Note: The waste heat does not peak at 15000 Watts of output power - the waste heat peaks at 50% to 80% of full power or under certain reflected power conditions.

R15001 Specifications

Interlocks:	External:	External interlock provided for disabling RF output power
	Valve: (Optional on units manufactured before April 1, 2009)	Prevents/disables RF power output if external water valve is missing or unplugged. (standard units ignore this interlock – consult factory if valve interlock is required)
	Water Flow: (Standard on units manufactured April 1, 2009 and later)	Prevents/disables RF power output if external water valve assembly is missing or unplugged. Prevents/disables RF power output if coolant water flow is insufficient.
Interface Connections:	Analog Interface:	25 pin Female D-Sub Connector
	Serial Interface:	9 pin Female D-Sub Connector
	CEX Input:	Female type BNC connector, 3 to 8V Peak-to-Peak sine wave, 50 Ohms Nominal Impedance at specified operating frequency.
	CEX Output:	Female type BNC connector, 5 to 8V Peak-to-Peak into 50 Ohms at specified operating frequency.
	VALVE	4-Pin Male Disk-Drive Connector
Power Monitor Scaling:	Forward Power Monitor	Monitor output is linearly proportional to 0 to 15000 Watts of forward power. Output scaling is 5.0VDC at 15000 Watts (0.33mV/Watt) or 10.0VDC at 15000 Watts (0.66mV/Watt), depending on the analog voltage range selected. (Default scaling)
	Reflected Power Monitor	Monitor output is linearly proportional to 0 to 1000 Watts of reflected power. Output scaling is 5.0VDC at 1000 Watts (5mV/Watt) or 10.0VDC at 1000 Watts (10mV/Watt), depending on the analog voltage range selected. (Default scaling)
Analog Setpoint Sensitivity:	In Power Control mode, analog setpoint sensitivity is 15000 Watts at 5.0VDC (0.33mV per Watt) or 15000 Watts at 10.0VDC (0.66mV per Watt), depending on the analog voltage range selected.	

R15001 Specifications

Labels:	Safety:	Per customer requirements. Labels may include Hazardous Voltage, Heavy Object
	Identification:	Seren IPS Inc. part number, serial number, and customer part number (optional), RF output frequency
Battery:	Internal, 3V 255mAh, 23mm Coin Style, Type BR2330 or CR2330 (For retention of user-configurable settings)	
Supplied Accessories:	Solenoid Water Valve with water flow sensor Product Information CD-ROM	
Dimensions inch (mm):	10.50 (266.70) High x 19.00 (482.60) Wide x 33.12 (841.25) Deep. Width includes Rack Mounting Brackets. Width without Rack Mounting Brackets: 17.00 (431.80) Depth includes Mains Power Connection Terminal Box	
Weight:	162.5Lbs (73.70Kg)	

Physical Dimensions

Models R101, R101MKII, R301, R301MKII, L301, L101MKII, L301MKII

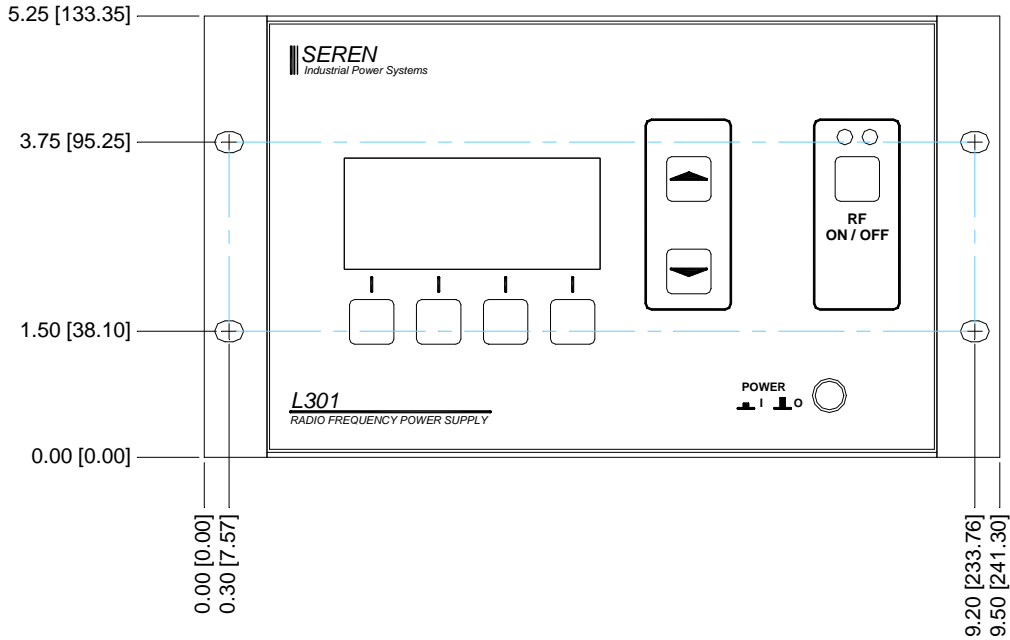

Front View

R101, R101MKII, R301, R301MKII, L301, L101MKII, L301MKII RF Power Supply
 Model L301 shown. Dimensions in Inch [mm]

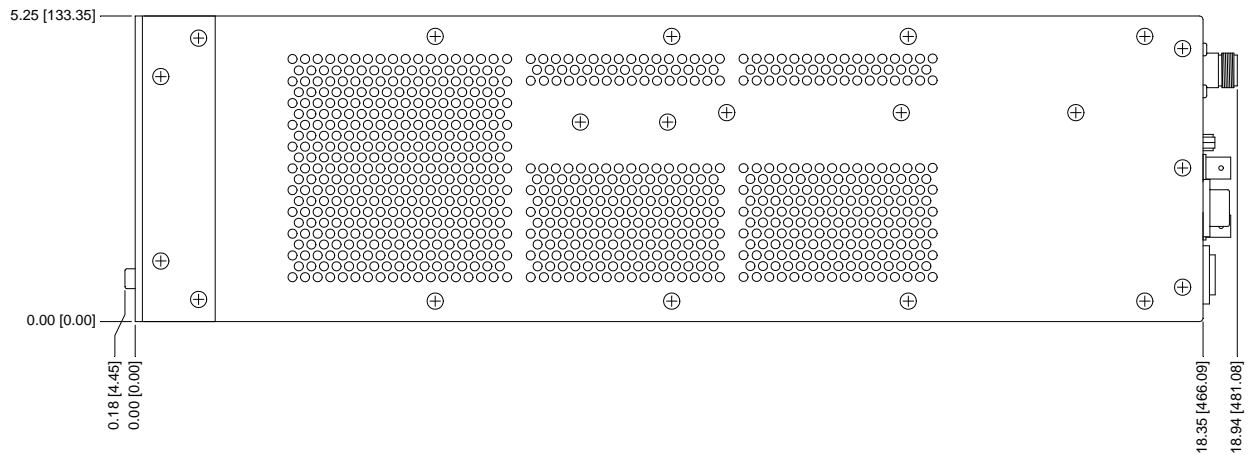

Side View

R101, R101MKII, R301, R301MKII, L301, L101MKII, L301MKII RF Power Supply
 Dimensions in Inch [mm]

Physical Dimensions:

Models R101, R101MKII, R301, R301MKII, L301, L101MKII, L301MKII

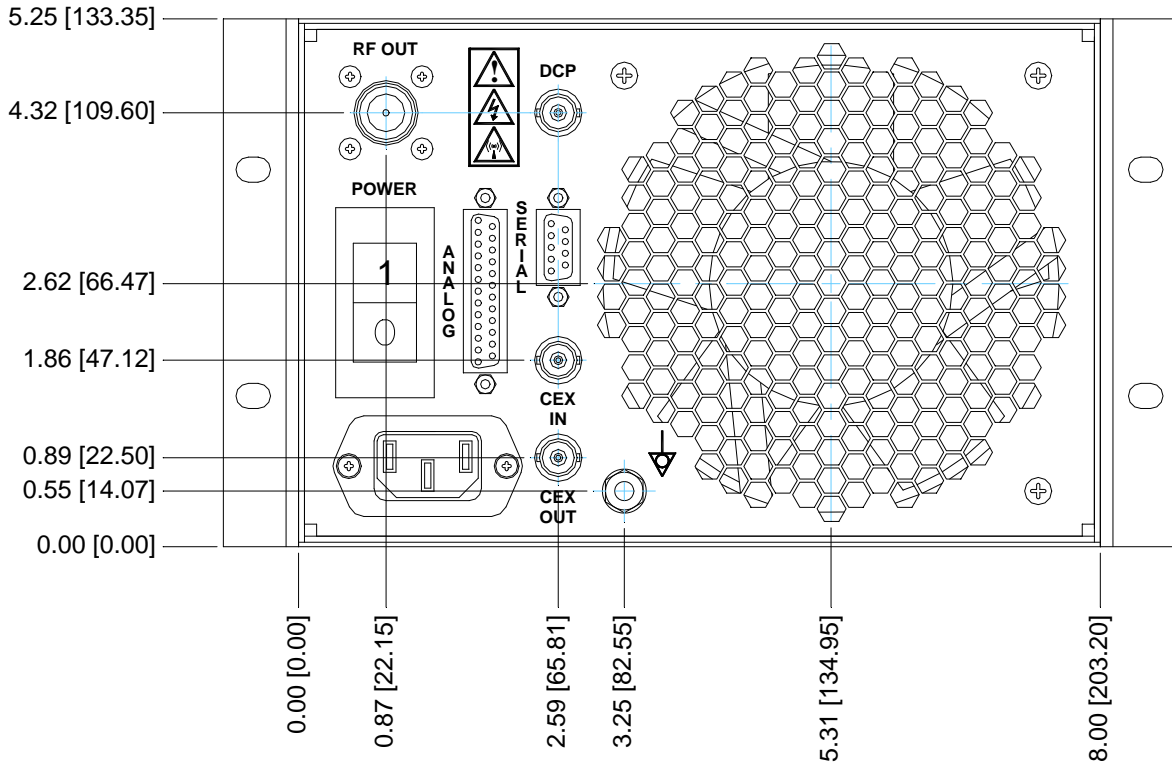

Rear View.

R101, R101MKII, R301, R301MKII, L301, L101MKII, L301MKII RF Power Supply
 Dimensions in Inch [mm]

Physical Dimensions: Models R601, L601, R1001, R1001W, L1001, L1001W

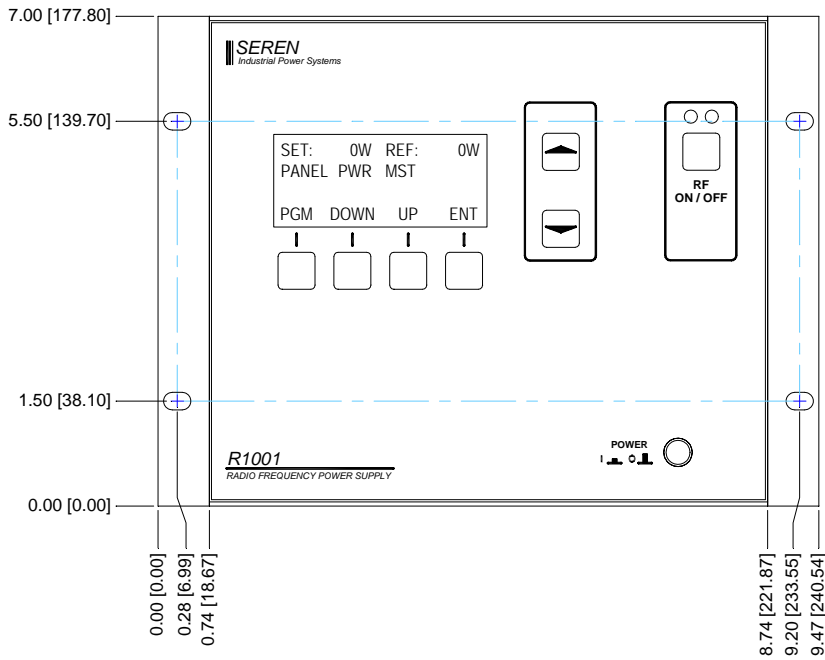

Front View, R601, L601, R1001, R1001W, L1001, L1001W,
Model R1001 shown

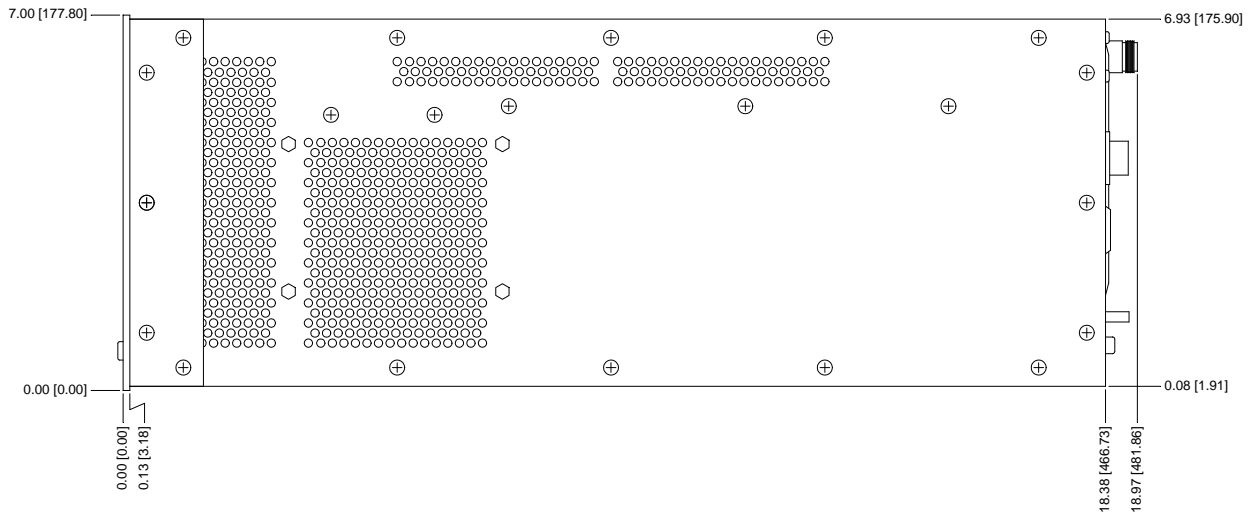

Side View, R601, L601, R1001, R1001W, L1001, L1001W

Physical Dimensions: Models R601, L601, R1001, R1001W, L1001, L1001W

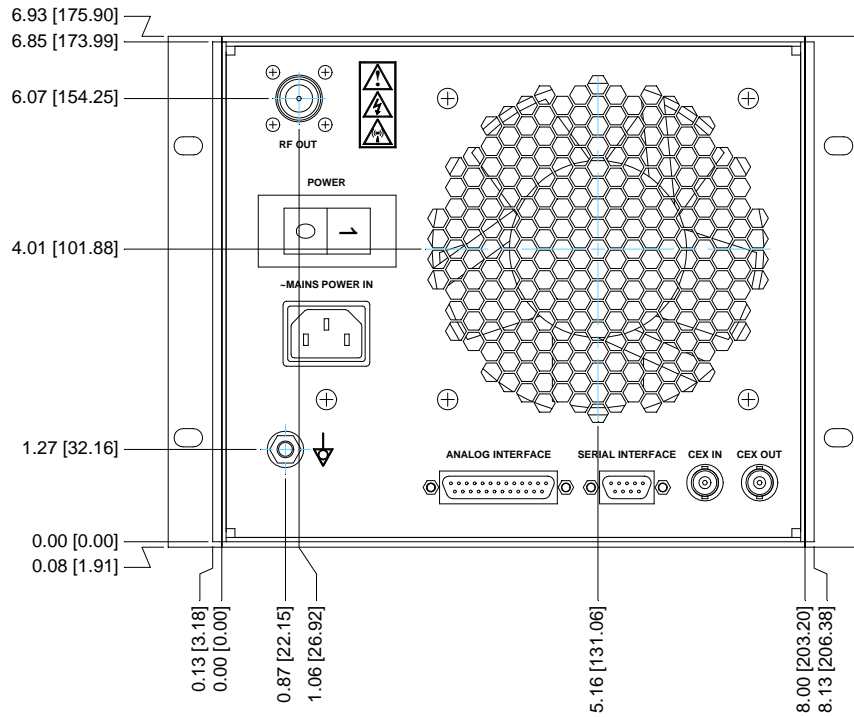

Rear View, R601, L601, R1001, L1001

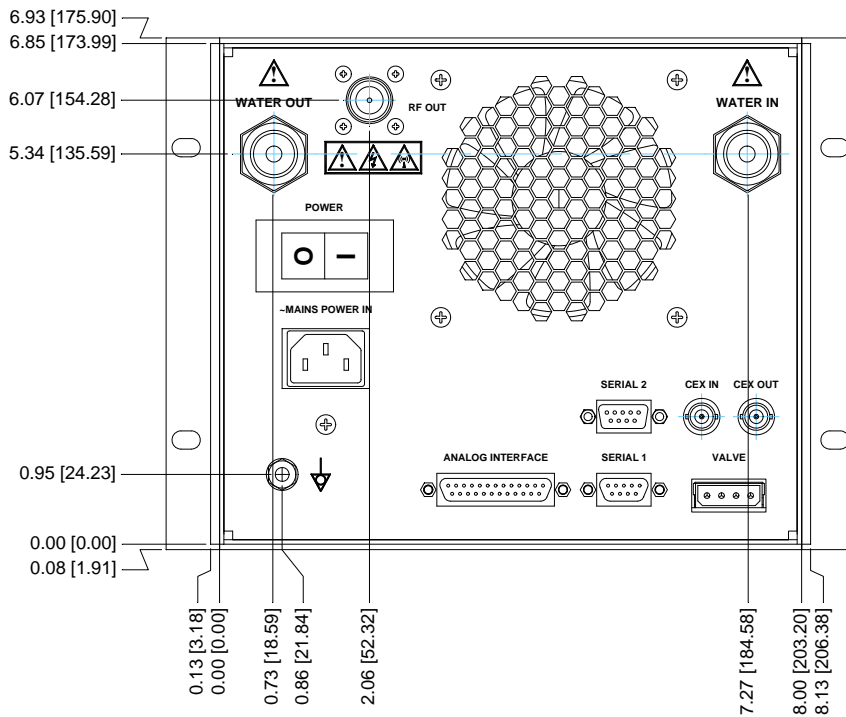

Rear View, R1001W, L1001W

Physical Dimensions: Models R2001, R2001H, L2001, L2001H, R3001, L3001

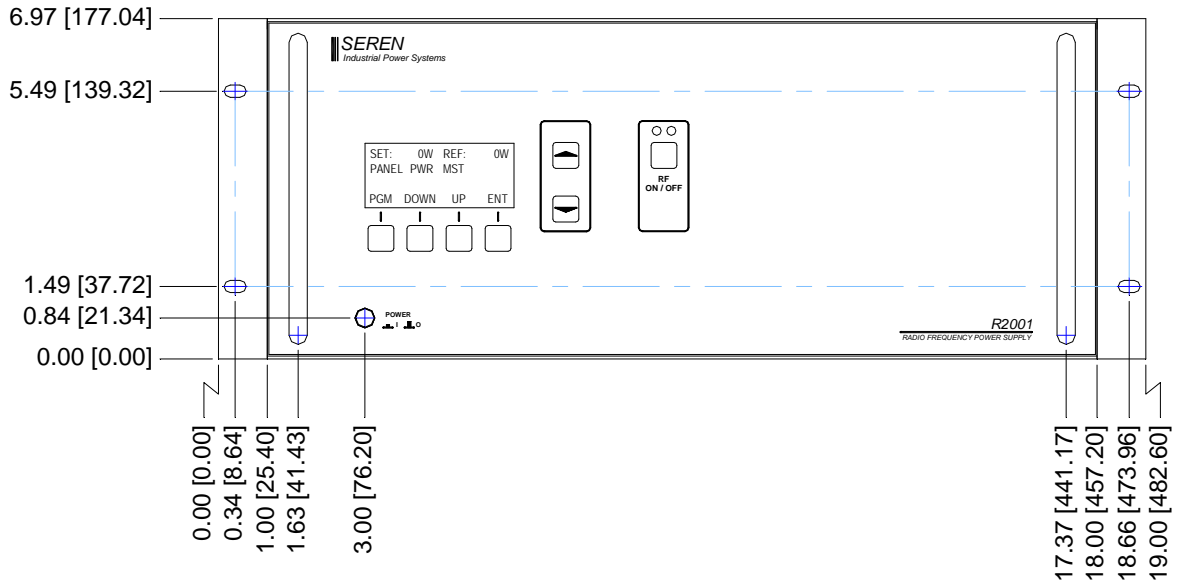

Front View, R2001, R2001H, L2001, L2001H, R3001, L3001
Model R2001 shown

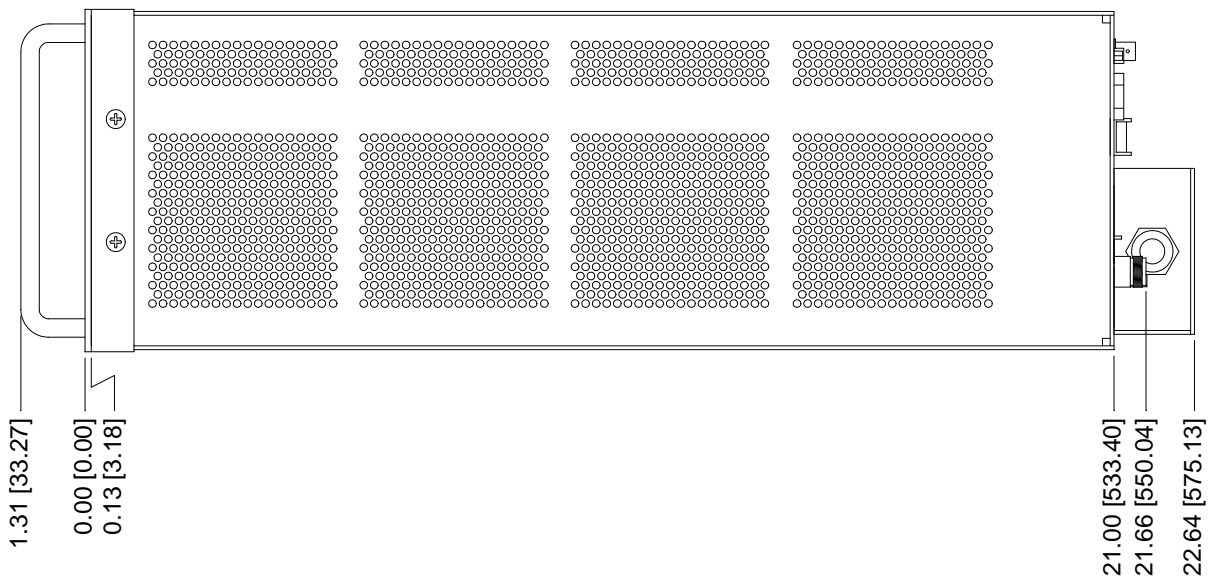

Side View, R2001, R2001H, L2001, L2001H, R3001, L3001

Physical Dimensions: Models R2001, R2001H, L2001, L2001H, R3001, L3001

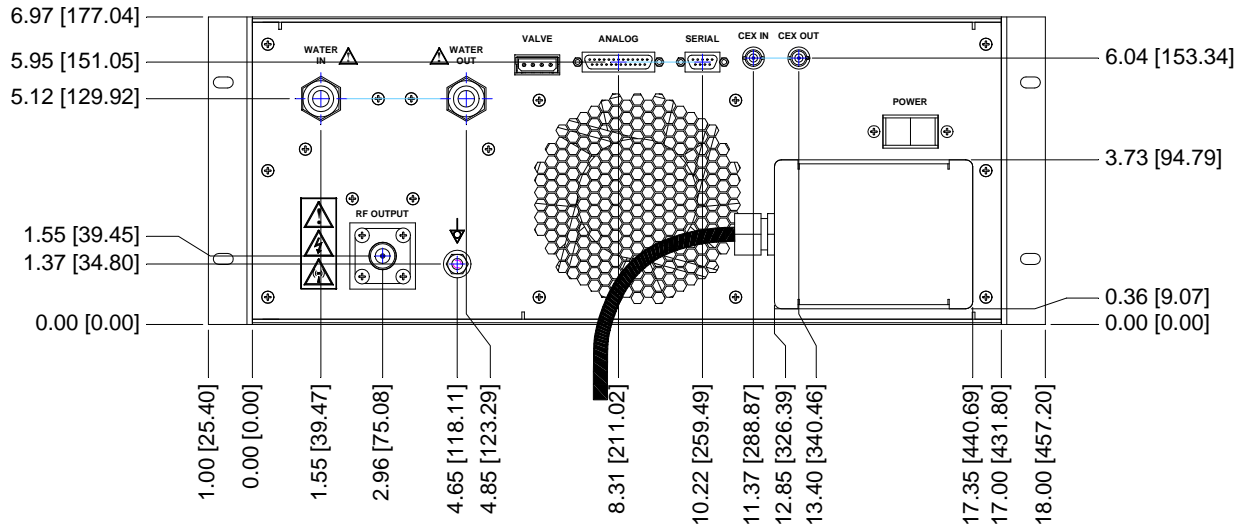

Rear View, R2001, R2001H, L2001, L2001H, R3001, L3001

Physical Dimensions: Model R4001, R5001 (4U Package)

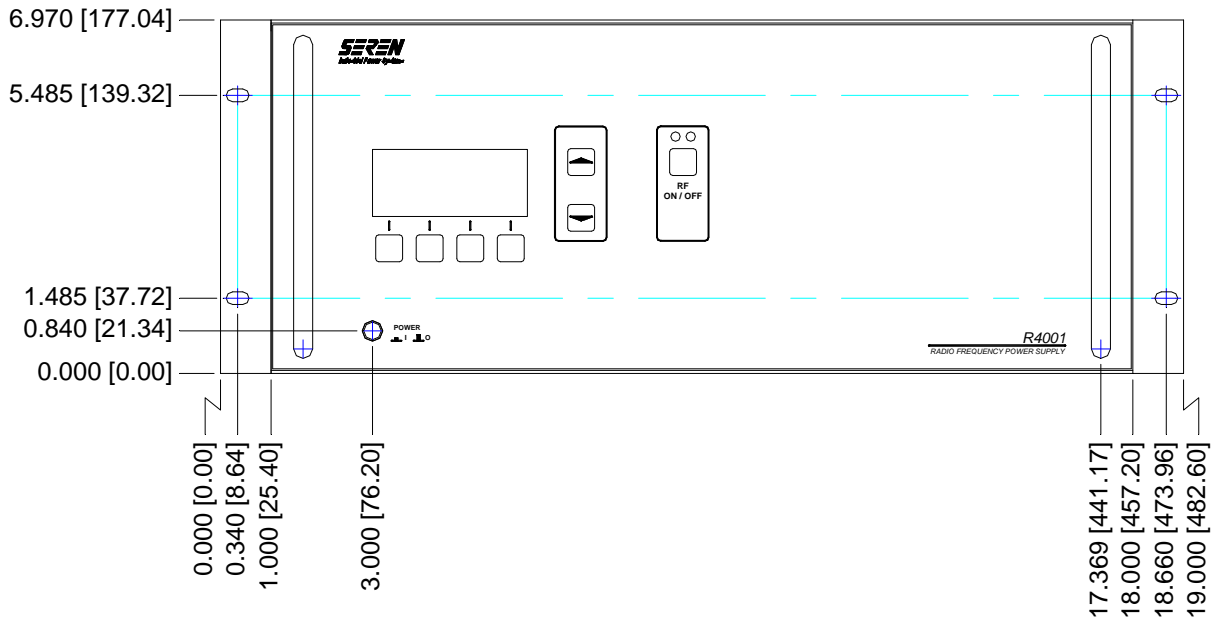

Front View, R4001, R5001 (4U Package)

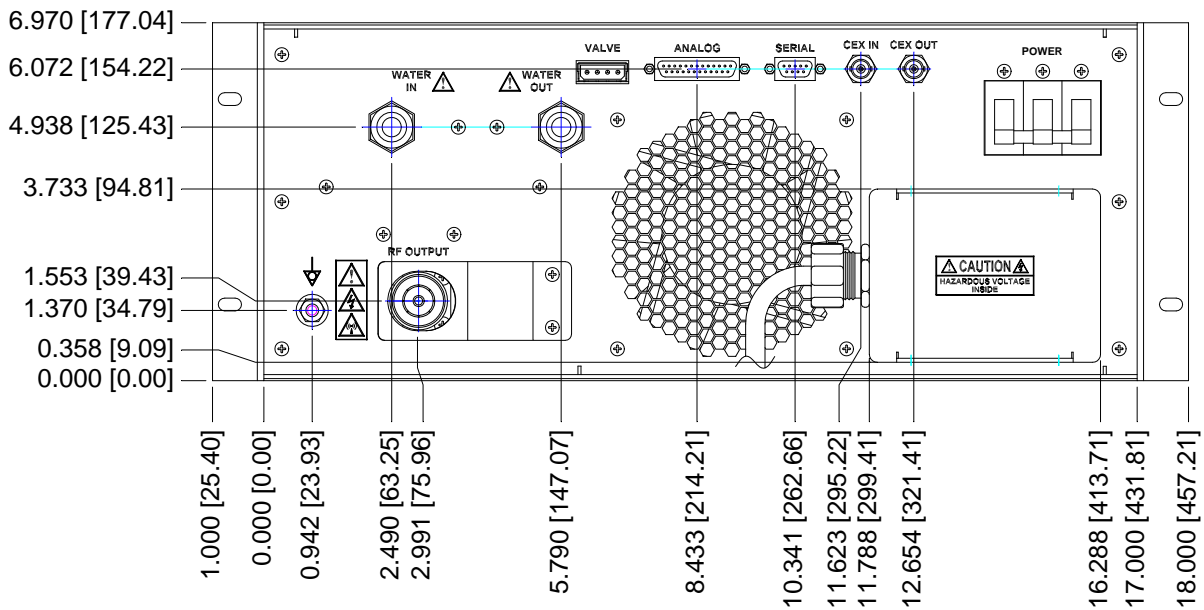

Rear View, R4001, R5001 (4U Package)

Physical Dimensions: Model R4001, R5001 (4U Package)

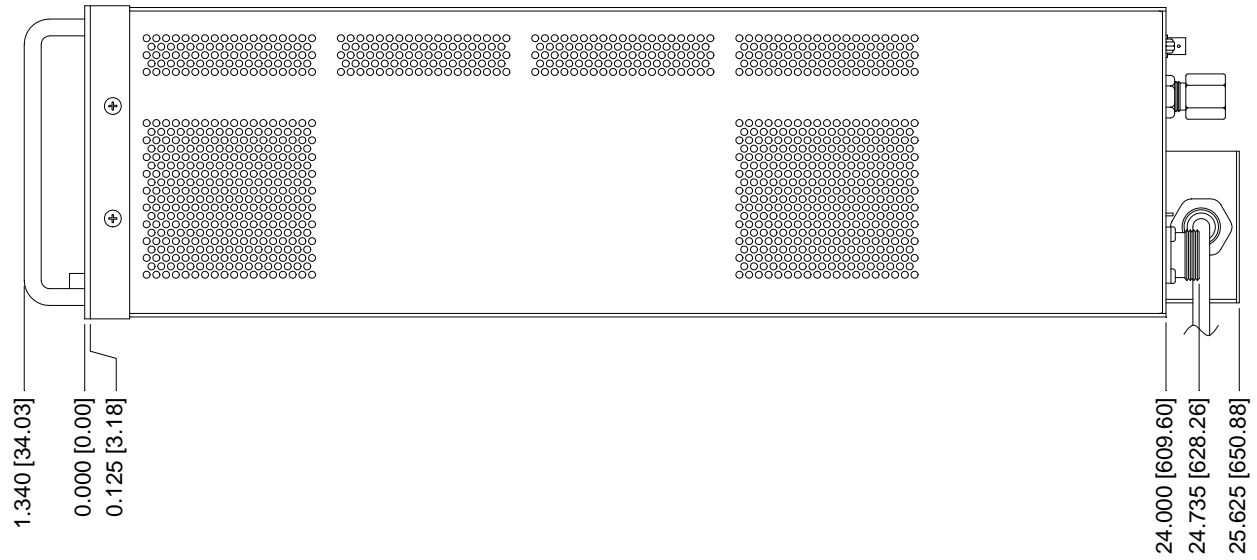

Side View, R4001, R5001 (4U Package)

Physical Dimensions: Models R5001, L5001 (5U Package)

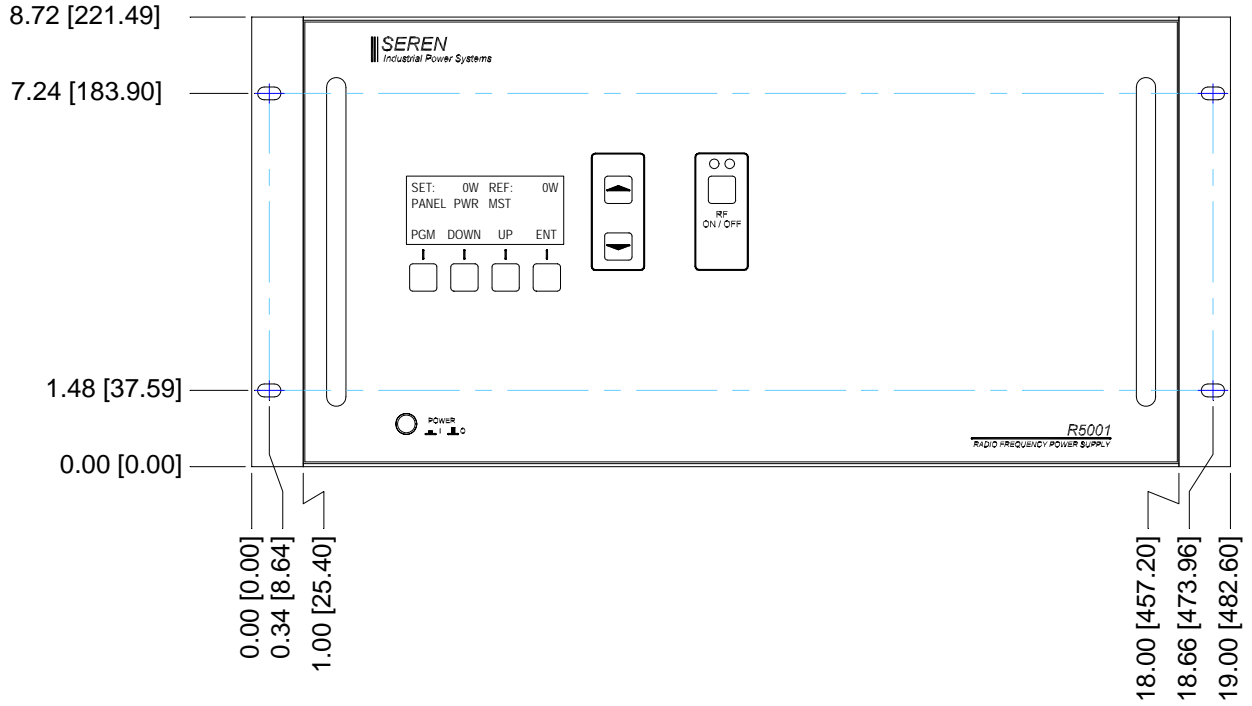

Front View, R5001, L5001 (5U Package)

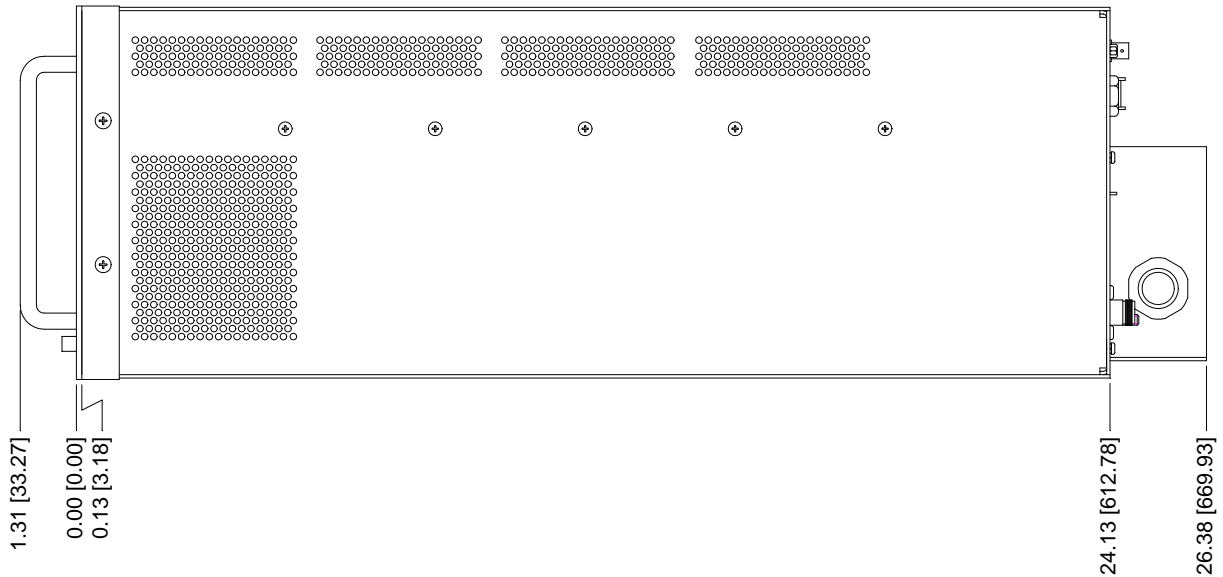

Side View, R5001, L5001 (5U Package)

Physical Dimensions: Model R5001 (5U Package)

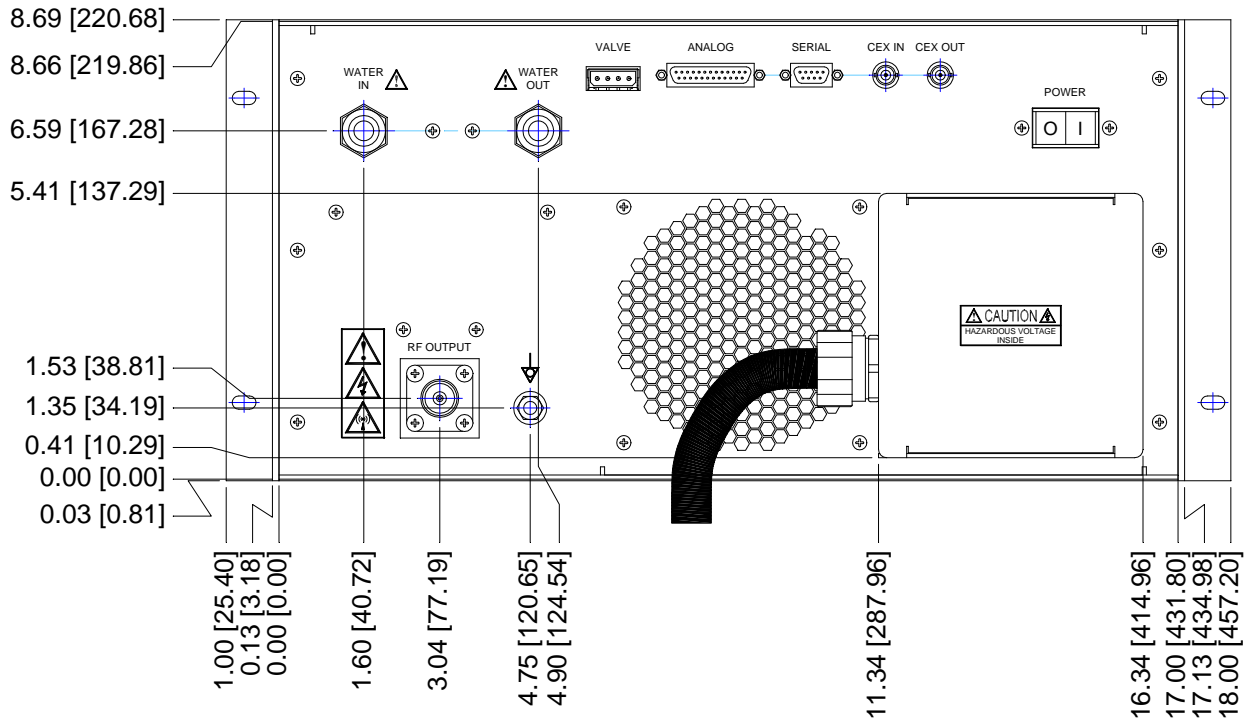

Rear View, R5001, L5001 (5U Package)

Physical Dimensions: Models R10001

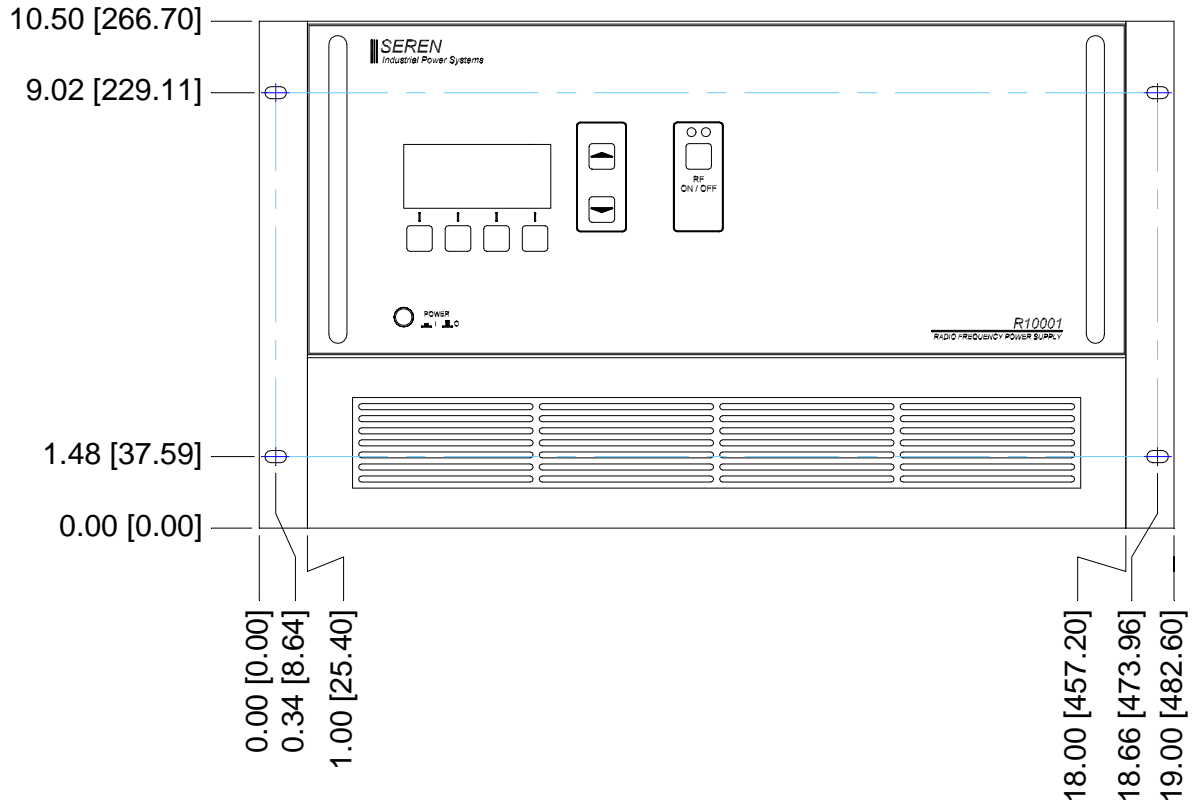

Front View, Model R10001

Physical Dimensions: Model R10001

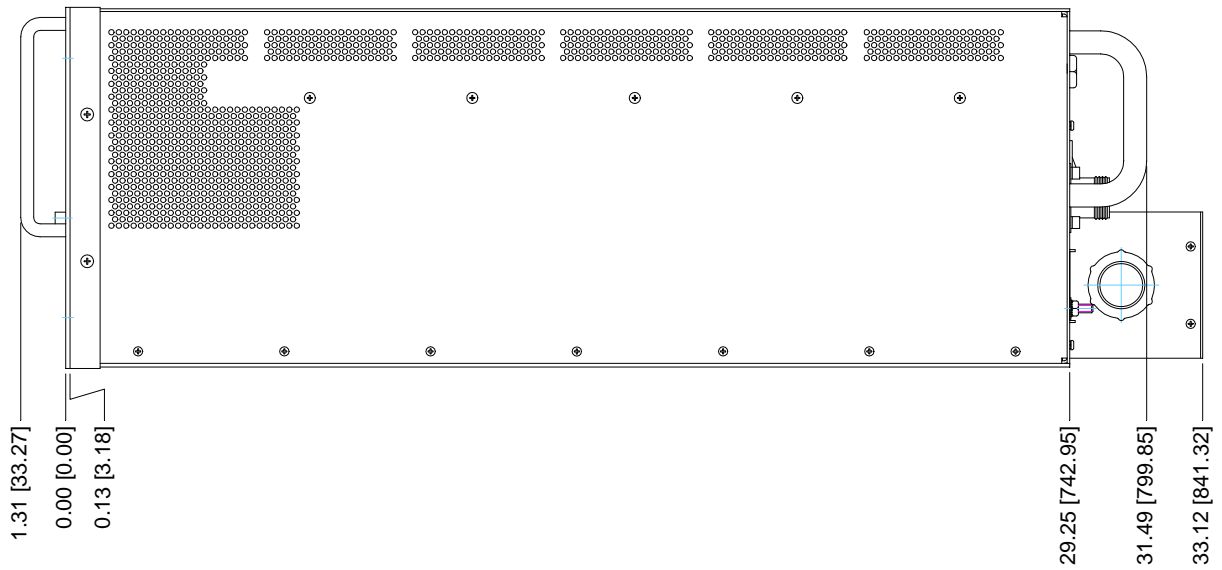

Side View, Model R10001

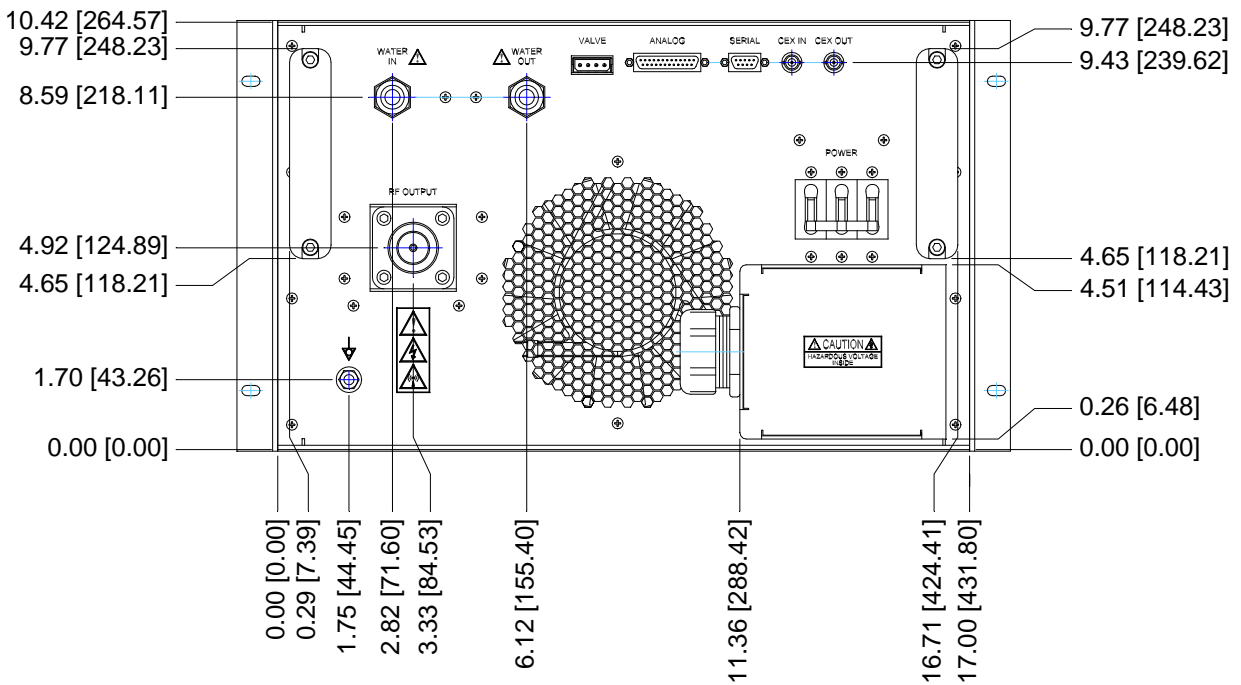

Rear View, Model R10001

Physical Dimensions: Model R15001

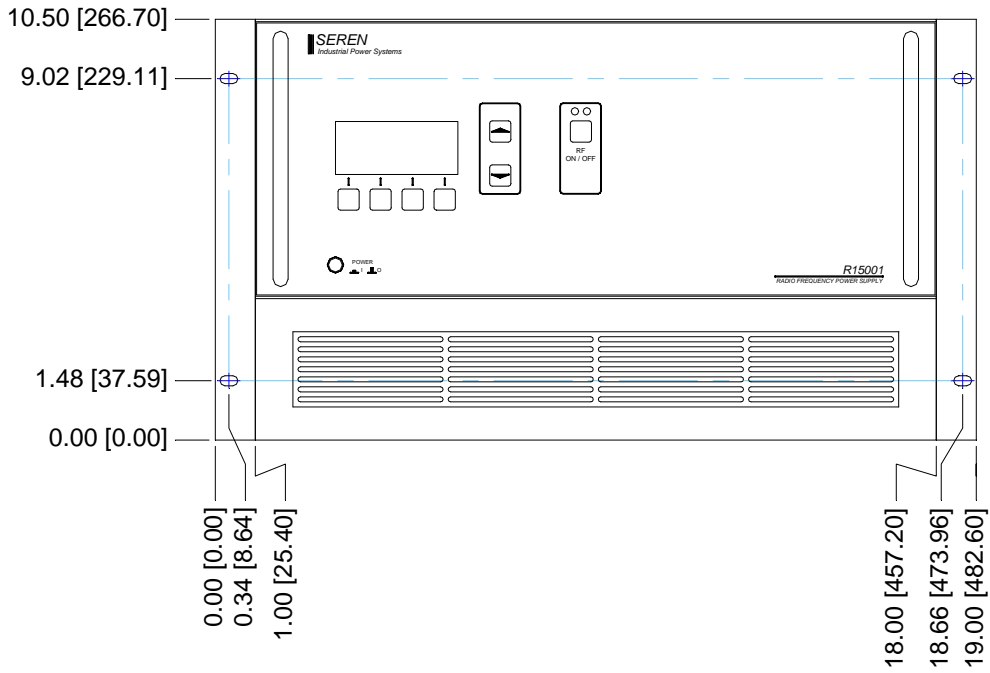

Front View, Model R15001

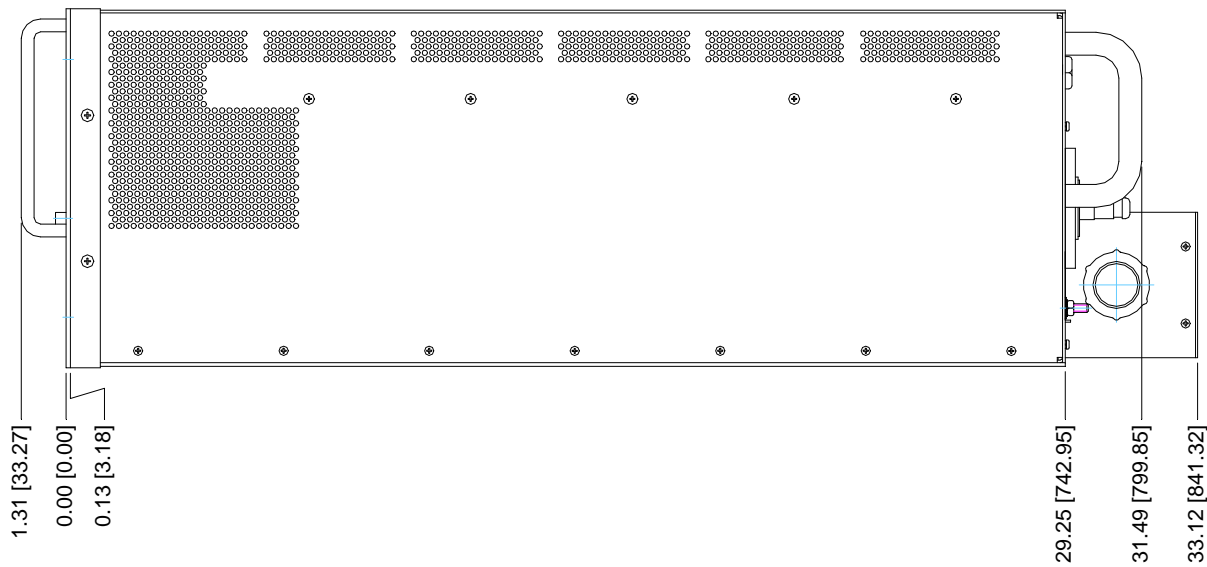

Side View, Model R15001

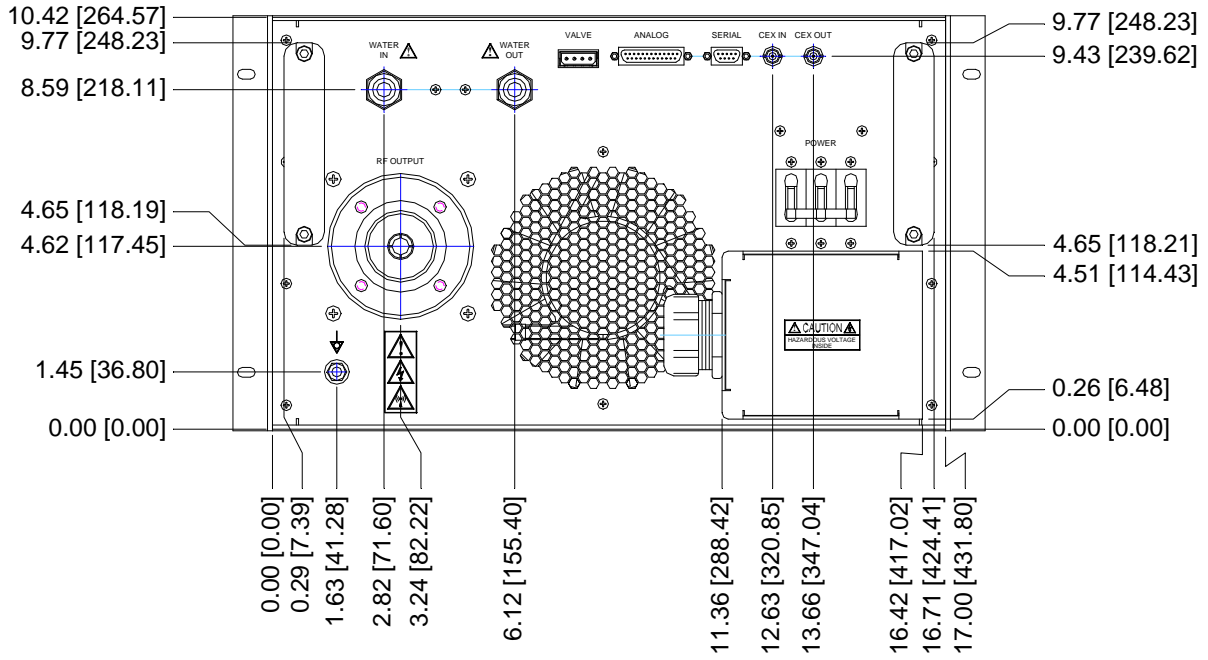

Rear View, Model R15001

Agency Compliance Information

R101MKII, R301MKII, L101MKII, L301MKII

Declaration of Conformity (CE)
In accordance with ISO/IEC Guide 22

Supplier:	Seren IPS Inc.
Address:	1670 Gallagher Drive Vineland, NJ, 08360 USA
European Representative:	RF Industries Ltd. Nork Works Nork Gardens, Banstead, Surrey, SM7 1NZ United Kingdom
Product:	RF Power Supply Models R101MKII, L101MKII, R301MKII, L301MKII

The product described above is in conformity with Essential Health and Safety Requirements of the Low Voltage Directive (LVD – 2006/95/EEC; EN 61010-1:2001 2nd Edition, EN 60204-1: 2006 +A1) as amended and with the Electromagnetic Compatibility Directive (EMC – 2004/108/EEC; EN55011:2007) as amended.

Low Voltage Directive 2006/95/EC

Safety Requirements for Electrical Equipment for Measurement, Control, and Laboratory Use – Part1: General Requirements	EN61010-1:2001 2 nd Edition
Safety of Machinery – General Requirements for Electrical Equipment of Machines	EN 60204-1:2006 +A1

Electromagnetic Compatibility Directive 2004/108/EC

Immunity:	EN61326:2006, EN61000-4-2:1995 +A1:1999 +A2:2001, EN61000-4-3:2006, EN61000-4-4:2004, EN61000-4-5:2005, EN61000-4-6:2007, EN61000-4-11:2004
Emissions:	EN 55011:2007 +A2:2007, IEC61000-3-2:2006, EN61000-3-3:1995 +A1:2001 +A2: 2005, EN61000-3-2:2006

Issued: Vineland, NJ, U.S.A. July 21, 2011

Lawrence A. Hooper

July 21, 2011

Lawrence A. Hooper
Director of Engineering

Date

R101, L101, R301, L301 (discontinued)

Declaration of Conformity (CE)
In accordance with ISO/IEC Guide 22

Supplier: Seren IPS Inc.

Address: 1670 Gallagher Drive
Vineland, NJ, 08360
USA

European Representative: RF Industries Ltd.
Nork Works
Nork Gardens,
Banstead, Surrey, SM7 1NZ
United Kingdom

Product: **RF Power Supply Models**
R101, L101, R301, L301

The product described above is in conformity with Essential Health and Safety Requirements of the Low Voltage Directive (LVD - 73/23/EEC) as amended and with the Electromagnetic Compatibility Directive (EMC – 89/336/EEC) as amended.

Low Voltage Directive 73/23/EEC

EN 60204-1: 1997 Safety of Machinery – General Requirements for Electrical Equipment of Machines

Electromagnetic Compatibility Directive 89/336/EEC

EN 61326:1997 +A1:1998, +A2:2001 EMC Requirements for Electrical Equipment for Measurement, Control, and Laboratory Use

EN 55011:1998/A1:1999 Generic Standard (Emissions) - Limits and Methods of Measurement of Radio Disturbance Characteristics of Industrial, Scientific and Medical (ISM) Radio-Frequency Equipment

Issued: Vineland, NJ, U.S.A. May 11, 2004

Lawrence A. Hooper

May 11, 2004

Lawrence A. Hooper
Director of Engineering

Date

R601, L601, R1001, L1001

Declaration of Conformity (CE)
In accordance with ISO/IEC Guide 22

Supplier: Seren IPS Inc.

Address: 1670 Gallagher Drive
Vineland, NJ, 08360
USA

European Representative: RF Industries Ltd.
Nork Works
Nork Gardens,
Banstead, Surrey, SM7 1NZ
United Kingdom

Product: **RF Power Supply Models**
R601, L601, R1001, L1001

The product described above is in conformity with Essential Health and Safety Requirements of the Low Voltage Directive (LVD – 2006/95/EEC; EN 61010-1:2001 2nd Edition, EN 60204-1: 2006 +A1) as amended and with the Electromagnetic Compatibility Directive (EMC – 2004/108/EEC; EN55011:2007) as amended.

Low Voltage Directive 2006/95/EC

Safety Requirements for Electrical Equipment for Measurement, Control, and Laboratory Use – Part1: General Requirements	EN61010-1:2001 2 nd Edition
Safety of Machinery – General Requirements for Electrical Equipment of Machines	EN 60204-1:2006 +A1

Electromagnetic Compatibility Directive 2004/108/EC

Immunity:	EN61326:2006, EN61000-4-2:1995 +A1:1999 +A2:2001 EN61000-4-3:2006, EN61000-4-4:2004, EN61000-4-5:2005, EN61000-4-6:2007, EN61000-4-11:2004
Emissions:	EN 55011:2007 +A2:2007, IEC61000-3-2:2006 EN61000-3-3:1995 +A1:2001 +A2: 2005, EN61000-3-2:2006

Issued: Vineland, NJ, U.S.A. March 7, 2014

Lawrence A. Hooper

March 7, 2014

Lawrence A. Hooper
Director of Engineering

Date

R2001, R2001H, L2001, L2001H, R3001, L3001

Declaration of Conformity (CE)
In accordance with ISO/IEC Guide 22

Supplier: Seren IPS Inc.

Address: 1670 Gallagher Drive
Vineland, NJ, 08360
USA

European Representative: RF Industries Ltd.
Nork Works
Nork Gardens,
Banstead, Surrey, SM7 1NZ
United Kingdom

Product: **RF Power Supply Models**
R2001, L2001, R3001, L3001, R5001

The product described above is in conformity with Essential Health and Safety Requirements of the Low Voltage Directive (LVD - 73/23/EEC) as amended and with the Electromagnetic Compatibility Directive (EMC – 89/336/EEC) as amended.

Low Voltage Directive 73/23/EEC

EN 60204-1: 1997 Safety of Machinery – General Requirements for Electrical Equipment of Machines

Electromagnetic Compatibility Directive 89/336/EEC

EN 61326:1997 +A1:1998, +A2:2001 EMC Requirements for Electrical Equipment for Measurement, Control, and Laboratory Use

EN 55011:1998/A1:1999 Generic Standard (Emissions) - Limits and Methods of Measurement of Radio Disturbance Characteristics of Industrial, Scientific and Medical (ISM) Radio-Frequency Equipment

Issued: Vineland, NJ, U.S.A. August 12, 2004

Lawrence A. Hooper

August 12, 2004

Lawrence A. Hooper
Director of Engineering

Date

R10001, R15001

Declaration of Conformity (CE)
In accordance with ISO/IEC Guide 22

Supplier: Seren IPS Inc.

Address: 1670 Gallagher Drive
Vineland, NJ, 08360
USA

European Representative: RF Industries Ltd.
Nork Works
Nork Gardens,
Banstead, Surrey, SM7 1NZ
United Kingdom

Product: **RF Power Supply Models**
R10001, R15001

The product described above is in conformity with Essential Health and Safety Requirements of the Low Voltage Directive (LVD - 73/23/EEC) as amended and with the Electromagnetic Compatibility Directive (EMC – 89/336/EEC) as amended.

Low Voltage Directive 2006/95/EC

EN 61010-1:2001 (2nd Edition)

Safety requirements for electrical equipment for measurement, control, and laboratory use, Part 1: General Requirements

Electromagnetic Compatibility Directive 2004/108/EC

EN 61326:2006

EMC Requirements for Electrical Equipment for Measurement, Control, and Laboratory Use

EN 55011:2007 +A2:2007

Generic Standard (Emissions) - Limits and Methods of Measurement of Radio Disturbance Characteristics of Industrial, Scientific and Medical (ISM) Radio-Frequency Equipment

Issued:

Vineland, NJ, U.S.A. April 21, 2011

Lawrence A. Hooper

April 21, 2011

Lawrence A. Hooper
Director of Engineering

Date

Semiconductor Equipment and Materials International (SEMI) Compliance

SEMI Safety, S2, and S8 compliance testing was conducted by an independent laboratory on representative samples of the product families listed below. Reproducing the laboratory reports here is beyond the scope of this document. The laboratory reports are furnished upon request. Laboratory and report references are listed below.

Laboratory:

TUV Rheinland Of North America, Inc.
 North American Headquarters
 12 Commerce Road
 Newtown, CT 06470
 Telephone: 203-426-0888, Fax: 203-426-4009
 Web: www.tuv.com E-Mail: info-new@us.tuv.com

Laboratory Reports:

R301MKII Product Family (Models R101MKII, L101MKII, R301MKII, L301MKII)	
SEMI Safety	EN60204-1:2006 +A1, TUV Rheinland Report number: 31171756.002
SEMI S2-0310	Evaluation Report: Environmental, Health, and Safety Guidelines for Semiconductor Manufacturing Equipment TUV Rheinland report number: 31171756.002
SEMI S8-0308	TUV Rheinland report number: 31171756.002

R1001 Product Family (Models R101, L101,R301, L301, R600, L600, R1001, R1001W, L1001)	
SEMI Safety	EN60204-1:1997, TUV Rheinland Report number: 30470472.001
SEMI S2-0703	Evaluation Report: Environmental, Health, and Safety Guidelines for Semiconductor Manufacturing Equipment TUV Rheinland report number: 30470472.002
SEMI S8-0701	TUV Rheinland report number: 30470472.002

R2001 Product Family (Models R2001, R2001H, L2001, L2001H, R3001, L3001, R5001)	
SEMI Safety	EN60204-1:1997, TUV Rheinland Report number 30470472.004
SEMI S2-0703	Evaluation Report: Environmental, Health, and Safety Guidelines for Semiconductor Manufacturing Equipment TUV Rheinland report number: 30470472.003
SEMI S8-0701	TUV Rheinland report number: 30470472.002

SEREN 1 Year Limited Warranty

SEREN IPS Inc. products are warranted to the original purchaser against defects in material and workmanship for a period of one year from the date of delivery.

SEREN IPS Inc. will repair or replace, at its option, all defective products returned freight prepaid during the warranty period, without charge, provided that there is no evidence the product has been mishandled, abused, or misapplied. Our liability under this warranty is limited to servicing, repairing, or replacing any defective products for a period of one year after delivery to the original purchaser.

If warranty service is required, the equipment must be returned, transportation charges prepaid, to our factory or authorized service depot. In the case of misuse, abnormal operating conditions, or other non-warranty work, a repair cost estimate will be submitted for approval before work is started.

WHAT THE WARRANTY DOES NOT COVER:

This warranty covers only defects in materials and workmanship provided by SEREN I.P.S. and does not cover equipment damage or malfunction from misuse, abuse, accident, act of God, non-SEREN I.P.S. modification or upgrade. Improper return shipping, packaging, or shipping damage is not covered. SEREN I.P.S. will not be liable for any incidental or consequential damages resulting from your use or inability to use your RF Power Supply.

IF YOU HAVE A PROBLEM

The first step is to contact your system vendor. Consult with your system vendor to determine the nature of the problem. Your system vendor knows the intimate details of how your processing system interfaces and operates with the RF Power Supply and can efficiently resolve system related problems.

If it is determined that the RF Power Supply has a problem, contact our customer service department at **1-856-205-1131**. Before you call, please be ready to provide the model of your RF Power Supply, its serial number, date of manufacture, a description of the problem, and the model and manufacturer of the processing system it is used on.

HOW IS WARRANTY SERVICE OBTAINED?

Our customer service representative will explain how to obtain service under this warranty. Please save the original packing materials in order to facilitate shipment.

Glossary of Terms

A	Amperes, a measurement unit of current
AC	Alternating Current
AC Mains: 3-Phase Delta	3-Phase 4-Wire system. 3 phases and a protective earth (ground) conductor.
AC Mains: 3-Phase Wye	3-Phase 5-Wire system. 3 phases with a neutral conductor and a protective earth (ground) conductor. Seren IPS equipment configured for 3-Phase Wye AC mains requires the neutral conductor to be connected.
ANLG	Abbreviation, "Analog"
Chamber	Industry term for a vacuum chamber used in plasma processing equipment.
Common Exciter (CEX)	A method of using an external frequency source to synchronize the outputs of RF Power Supplies in a multi-power supply system.
CPU	Central Processing Unit: computer
CW	Continuous Wave (not pulsed)
DC	Direct Current
D-Sub	Industry term for D-Subminiature connector
Equipotential Bond Equipotential Bonding	Equipotential bonding (often referred to as grounding) is used to control RF circulating currents within a system. For regulatory purposes, it is not a "Protective Earth" or "Safety Ground", even though it may be bonded to the "Protective Earth" or "Safety Ground" within the equipment or user's facility.
Exciter	A Radio Frequency source. RF Power Supplies amplify a RF signal source. The RF frequency signal source may be internally generated or externally supplied. (see Common Exciter).
Forward Power Leveling	Using the internal Forward Power sensor as the feedback source for power leveling (regulation).
FWD	Abbreviation, "FORWARD"
KHz	Kilo Hertz, a measurement unit of frequency (1000 Hertz)
KVA	Kilo Volt-Amperes

Glossary of Terms

Load (net) Power Leveling	(Forward Power) – (Reflected Power) = Net Power Using the calculated Net Power as the feedback source for power leveling (regulation).
Matchbox	Industry term for an impedance matching network
MHz	Mega Hertz, a measurement unit of frequency (1,000,000 Hertz)
mV	Milli-Volts, a measurement unit of Voltage, equal to 1/1000 of a Volt.
Net Power	The difference between forward power and reflected power.
Non-Volatile Storage	Also know as non-volatile memory. Computer memory that retains its data after power has been removed.
RF	Radio Frequency
RF Generator	Industry term for Radio Frequency Power Supply
SEMI	Industry standards organization: Semiconductor Equipment and Materials International
TTL	Transistor-Transistor Logic
Tuner	Industry term for an impedance matching network
VAC	Volts, Alternating Current
VDC	Volts, Direct Current
VFT	Variable Frequency Tuning. The RF power supply's CPU monitors the reflected power and adjusts the RF output frequency to minimize the reflected power. This often eliminates the need for an expensive external automatic impedance matching network. An inexpensive matching transformer (sold separately) and a VFT-capable RF power supply can be combined to form a cost-effective system solution.
VLT	Abbreviation, "VOLTAGE"
Voltage Control	Using an external DC voltage derived from the processing system as a feedback signal for power leveling (regulation)
W	Watts

Revision History:

Revision	Date	Revision Description
0.01	10/19/03	Preliminary
0.02	10/27/03	Updated Table of Contents, Analog Interface, and Technical Data Sections.
0.03	12/18/03	Deleted "A" from R301 model number, Output frequency was 100-460KHz, updated illustrations.
0.04	4/1/04	Corrected Typical Interface Connection diagram, added maximum current and inrush current to technical specifications.
0.05	11/22/04	Added descriptions of probe inverter option, updated analog interface connector to include probe inverter option, added sections "External Feedback with Probe Inverter Option" and External Feedback with SEREN IPS AT-Series Matching Network", added Programmable Parameter Reference and Programmable Parameter Detail sections, expanded problem solving chart, updated serial interface connector section. Added frequency configuration note in programmable parameters.
0.06	12/9/04	Added serial commands, updated serial connector pin-out to include RS-422 and RS-485.
0.07	5/13/05	Added Models R/L601, R/L1001, R1001W, R/L2001, R/L2001H R/L3001, R5001.
0.08	5/31/05	Corrected serial connector pin-out (RS-485-2 wire connections) & updated illustrations
0.09	6/21/05	Updated pulsing specification, updated RFENABLED* output circuit diagram
1.00	8/31/05	Formal Release
1.01	9/8/05	Minor corrections, added 3-Phase power information to technical specifications for R2001, L2001, R3001, L3001 models
1.02	9/15/05	Updated programming menu and serial commands.
1.03	3/10/06	Corrected Metering Accuracy (Forward Power) in specifications section – was not consistent.
1.04	8/31/06	Added models R10001 (27MHz), R10001, RS-485 communication details, Modbus communication details.
1.05	4/17/07	Corrected R10001 (13.56MHz) coolant water flow rate - was "6.0 gallons/minute minimum".
1.06	4/27/07	Corrected maximum current and power plug type for R2001H, L2001H, R3001, and L3001 3-phase models.
1.07	5/4/07	Corrected "Q" and "R" command responses (pg 36 & 37), Character #6, bit 1: was "Bit 1: 1=External Interlock OK, 0=External Interlock Open"
1.08	12/20/07	Corrected Description of display line 3 on page 11: was "User Configurable Display Line"
1.09	2/15/08	Corrected R5001 ratings – Current was "25A Maximum", Power required was "5700VA Maximum".
1.10	2/17/09	Added Model R15001. Revised coolant water flow rate for R5001, R10001. Added XRP feature, added Arc Suppression feature. Added serial commands ALD, ATN, MLD, MTN, GOTO. Added references to DeviceNet operation.

RX01/LX01 SERIES RF POWER SUPPLY OPERATOR'S MANUAL

Revision	Date	Revision Description
1.11	3/18/09	Corrected R1001, R1001W, and L1001 technical specifications – deleted reference to “High Range/Low Range” – high/low range feature not supported on products 1KW & up. Revise pulse frequency spec – was “0 to 1,000Hz”.
1.12	3/19/09	Revised R10001 & R15001 maximum reflected power specification – changed from 1000W to 800W.
1.13	10/23/09	Added “WTR” and “HDW” alarms to troubleshooting section. Added “HDW” alarm flag (character 6, bit 2) to “Q” and “R” command responses Corrected “Q” and “R” command RFON&OK status flag (character 5, bit 3) description. Added “RF output frequency” to Technical Specifications, Identification on all models. Changed RF output frequency specification on all L-Series models from “100-460KHz” to “350-460KHz, other frequency ranges available - consult the factory”. Corrected VA rating on models R15001. Corrected minimum coolant water flow rate on R2001H, R3001, L3001, and R5001 – changed from 3.0GPM to 2.0GPM. Updated programming menu and serial command descriptions. Added Model R4001, added Pulsing Operation section.
1.14	12/8/09	Added Model R5001 4 Rack Unit (4U) high package, part number series 960096XXXX, identified R5001 5RU package models by part number series.
1.15	1/26/10	Updated Model R5001 4U package specifications section.
1.16	2/18/10	Added pollution degree level to environmental specifications and installation instructions. Corrected VA rating for models R10001 and R/L2001. Added “+/- 1 Watt” to Power Metering Accuracy (Forward Power) specification for all models.
1.17	6/17/10	Revised power cord specification for R10001 and R15001 products, added 27.12MHz and 40.68MHz frequency options to R10001 (10KW) specification.
1.18	1/4/11	Added rated and operating AC mains voltage ranges to all models, noted type of power cord (detachable or captive) on all models, added RF output connection instructions.
1.19	3/31/11	Updated water cooling installation instructions, added maximum water pressure specification (water-cooled units only), added Short-Circuit Current Rating (SCCR), added note regarding AC mains supply circuit breaker interrupting current rating/requirements. Corrected R301MKII/L301MKII Nominal & Operating voltage range. Added Emergency Off (EMO) section and periodic maintenance tasks.
1.20	4/21/11	Added R10001/R15001 CE Declaration Of Conformity

RX01/LX01 SERIES RF POWER SUPPLY OPERATOR'S MANUAL

Revision	Date	Revision Description
1.21	6/8/11	Corrected height, in millimeters (mm), in specifications section for models R601, L601, R1001, R1001W, L1001, R2001, R2001H, L2001, L2001H, R3001, L3001, R4001, R5001 (4U package), R10001, R15001. Corrected depth, in millimeters (mm), in specifications section for models R5001 (5U package).
1.22	8/5/11	Added L101MKII model information. Added SEMI S8 compliance information. Corrected inconsistencies with AC mains ratings, rear panel illustrations, added equipotential bonding stud information, and updated CE declaration of conformity for models R/L101MKII and R/L301MKII. Corrected weight of R/L301MKII, R/L101MKII (was 27lbs).
1.23	8/10/11	Added L5001 model information.
1.24	8/12/11	Corrected R/L5001 (5U) specifications - power plug.
1.25	10/20/11	Corrected R/L301MKII & R/L101MKII EMC Standard numbers (typo).
1.26	7/3/12	Corrected R10001/R15001 CE Declaration of Conformity directive numbers.
1.27	8/14/12	Added dimensions to R/L2001-3001 front panel illustration, re-referenced dimensions on R4001-R5001 (4U) front panel illustration.
1.28	2/8/13	Added 27.12MHz and 40.68MHz frequency options to R601 and R1001 specifications.
1.29	2/12/13	Added 27.12MHz and 40.68MHz frequency options to R2001, R2001H, R3001, R5001 (4U) specifications.
2.00	12/13/13	General Maintenance: Updated programming menu information and serial commands. Added DeviceNet information (formerly a separate document). Added/Expanded AC Mains connection details in the installation section. Added 380-415V AC mains specifications/details to specifications for 3-phase units. Rear panel fan on R/L101MKII, R/L301MKII, R/L601, R/L1001 was rated at 110CFM, changed to 123CFM. Added model L1001W. Rear panel fan on R/L1001W was rated at 47CFM, changed to 60CFM. Removed references to model R8001. Removed "Frequency Stability" spec - spec ambiguous - units use crystal-controlled DDS. Expanded environment specifications.
2.01	3/10/14	Revised R1001 product family CE Declaration of Conformity - updated directives.
2.02	4/23/14	Revised power metering accuracy specification, all models (except those noted as discontinued) from "+/-3% of Reading, +/-1W" to "+/-2% of Reading, +/-1W"
2.03	4/1/19	Revised models R601, L601 AC mains input specification - Changed from "Rated: 100-240V, Operating: 90-264V" to "Rated: 117-240V Operating 105-264V" Revised models R1001, L1001, R1001W, L1001W, R2001, R2001H, L2001, L2001H, R3001, L3001, R4001, R5001, L5001 AC Mains input specifications - Changed "Rated: 200-240V, Operating: 180-264V" to "Rated: 208-240V Operating: 190-264V"

Notes: