

Working with Turbopumps

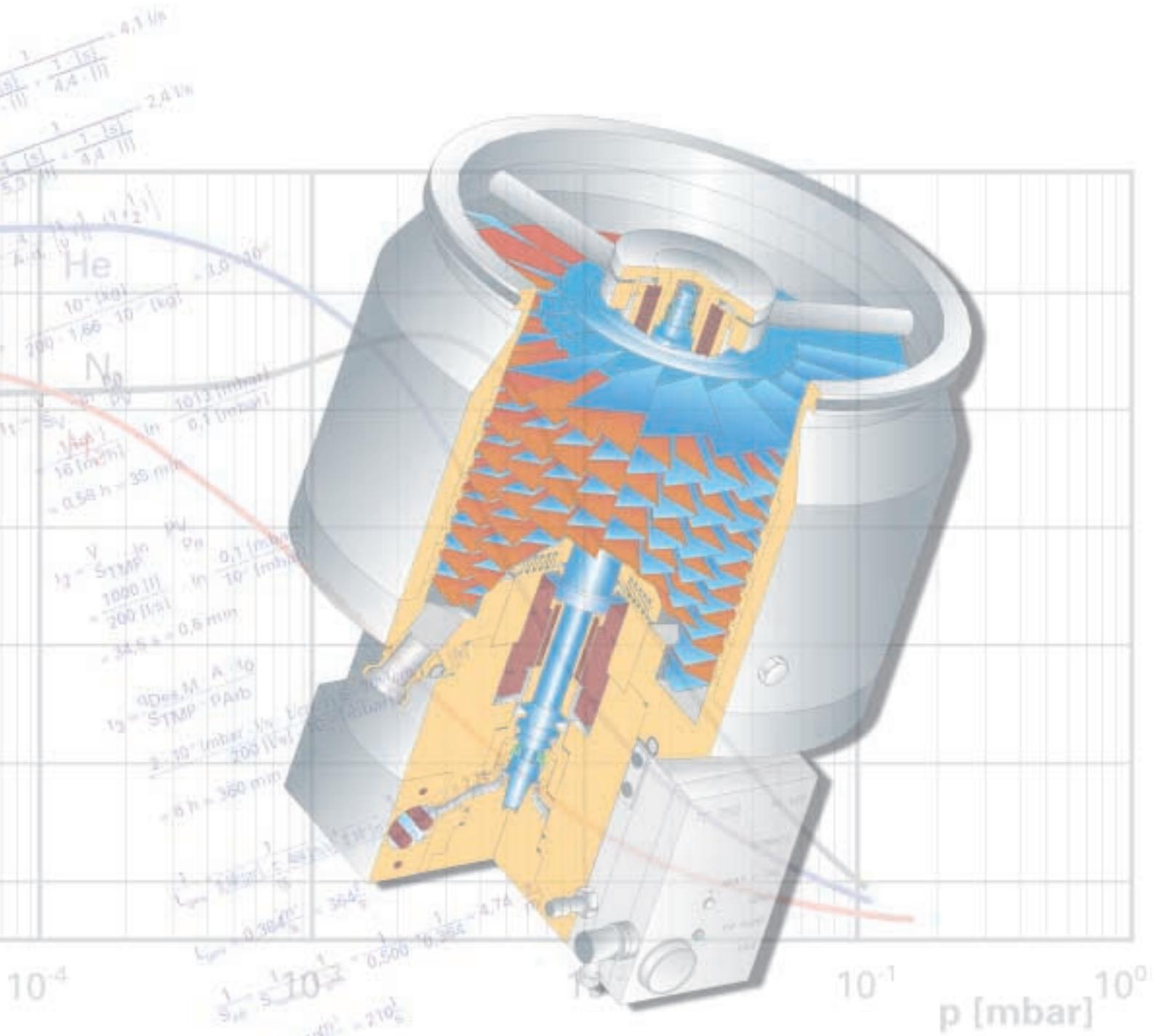

Introduction to high and ultra high vacuum production

Working with Turbopumps

Foreword

Empty space, meaning a volume not filled with air or any other gas is referred to as a vacuum. Ideal vacuum conditions exist in interstellar space. In interstellar space there is a particle density of one atom per cm^3 . In a laboratory or in industry, a vacuum is created using various vacuum pumps. Different requirements pertaining to the quality of the vacuum are placed on the vacuum depending on the application. For this reason, vacuum applications are divided into the following categories: rough, medium, high and ultra-high vacuum.

One of the most important instruments for creating high vacuum is the turbomolecular pump (TMP), also referred to as a turbopump, that was developed and patented in 1957 by Dr. Willi Becker at Pfeiffer Vacuum. The turbopump quickly became a success and now is more widespread than the diffusion pump which was the most widely used type of pump up until that time. Its ease of operation, its long life and the oil-free high vacuum it creates are the reasons to this day for the success of the turbomolecular pump.

Even today, 250,000 pumps later, Pfeiffer Vacuum is the innovative world market leader for this pump.

“Working with Turbopumps” covers the basic principles concerning the use of turbopumps for the generation of vacuum.

The content of this brochure is orientated to the most important questions that arise concerning the generation of vacuum:

- ▶ What terminology is used in vacuum technology and how is it defined? (Chapter 1).
- ▶ How does a turbopump function? (Chapter 2).
- ▶ What are the various types of turbopumps and what are the differences? (Chapter 2).
- ▶ What must I know in order to operate and to service a turbopump? (Chapter 3).
- ▶ What accessories are required and in what circumstances? (Chapter 3).
- ▶ Which combination of turbopump and backing pump is necessary for my process? (Chapters 4 and 5).
- ▶ Examples of applications (Chapter 6) and the data lists (Chapter 7) provide the answers to specific questions.

We hope that you will find this brochure an interesting and useful guide in your daily vacuum operations.

Figure 1.
The first turbopump developed and patented in 1957 by Dr. Willi Becker at Pfeiffer Vacuum.

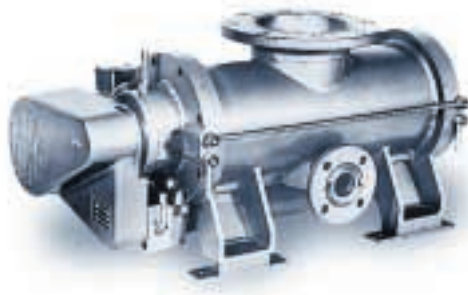

Index

| | Page |
|---|-----------|
| 1. Basic Principles and Definitions | 4 |
| 1.1 Terms used in Vacuum Technology | 4 |
| 2. Turbopump Overview | 8 |
| 2.1 The Principle | 8 |
| 2.2 Design and Operation | 8 |
| 2.2.1 Classical Turbopumps | 8 |
| 2.2.2 Characteristics..... | 9 |
| 2.2.3 CompactTurbo | 11 |
| 2.2.4 MagneticTurbo..... | 12 |
| 2.2.5 CorrosiveTurbo | 13 |
| 3. Operating Turbopumps | 14 |
| 3.1 Electronic Drive Units | 14 |
| 3.1.1 TC 100, 600 and 750 for Conventional Turbopumps | 14 |
| 3.1.2 TCP 350 as a Separate Drive Unit..... | 15 |
| 3.1.3 TCM 1601 for Magnetic Bearing Turbopumps | 15 |
| 3.1.4 Serial Interface | 16 |
| 3.2 Standby-Operations | 16 |
| 3.3 Rotation Speed Setting Mode | 16 |
| 3.4 Operating Modes for Various Gas Types | 16 |
| 3.5 Heating | 17 |
| 3.6 Venting | 17 |
| 3.7 Vibrations | 17 |
| 3.7.1 Frequency Analyses | 17 |
| 3.7.2 Anti-Vibration Unit..... | 17 |
| 3.8 Magnetic Fields | 18 |
| 3.8.1 Turbopumps in Magnetic Fields..... | 18 |
| 3.8.2 Magnetic Fields of Turbopumps..... | 18 |
| 3.9. Safety | 19 |
| 3.9.1 Operational Safety of the Turbopump | 19 |
| 3.9.2 Safety for Operating Personnel | 19 |
| 4. Applying and Dimensioning Turbopumps | 20 |
| 4.1 The most Important Parameters | 20 |
| 4.2 Applications without Process Gas | 21 |
| 4.2.1 Pumping Curves | 21 |
| 4.2.2 Pressure Range from 10^{-6} to 10^{-8} mbar | 24 |
| 4.2.3 Pressure below 10^{-8} mbar | 25 |
| 4.2.3.1 Baking Out | 25 |
| 4.2.3.2 Residual Gas Spectrum..... | 25 |
| 4.3 Applications with Process Gas | 26 |
| 4.3.1 Low Gas Loads < 0.1 mbar l/s..... | 26 |
| 4.3.2 High Gas Loads > 0.1 mbar l/s | 26 |
| 5. Intake And Outlet Line Losses | 28 |
| 5.1 Conductance Values for Molecular Flow | 28 |
| 5.2 Conductance Values for Laminar Flow | 30 |
| 6. Application Examples | 32 |
| 7. Data Lists | 34 |

1. Basic Principles and Definitions

1.1 Terms used in Vacuum Technology

This chapter explains the most commonly used terms in vacuum technology and illustrates the principles involved. In particular, terms that are directly connected to the use of turbomolecular pumps are explained. For detailed calculations, please refer to the chapter “Applying and dimensioning turbopumps” and “Intake and outlet line losses”.

A Absorption

Absorption is a sorption in which the gas (absorbate) penetrates into the interior of the solid body or liquid (absorbent).

Adsorption

Adsorption is a sorption in which the gas (absorbate) is bound to the surface of a solid body or liquid (absorbent).

Backing pump

A backing pump is a vacuum pump that generates the necessary exhaust pressure for a high vacuum pump from whose pumped gas flow is expelled against atmospheric pressure. A backing pump can also be used as a rough vacuum pump.

C Compression ratio

The compression ratio is the ratio of the outlet pressure to the intake pressure of a pump for a certain gas.

D Desorption

Desorption is the release of absorbed or adsorbed gases from a surface. The release can be spontaneous or be accelerated by physical processes.

E Exhaust pressure

The exhaust pressure (p_{VV}), also known as the fore-vacuum pressure, is the pressure on the fore-vacuum side of the turbopump. A turbopump cannot expel against atmosphere and requires, therefore, a vacuum on the exhaust side (the fore-vacuum) which, depending on type, must be between 0.01 and 20 mbar. Diaphragm pumps, oil-sealed rotary vane pumps, Roots pumps or other dry backing pumps are used to generate the vacuum.

F Final pressure

The final pressure is the value of the pressure that is asymptotically approached in a blanked off vacuum pump under normal operation and without the admission of gas.



Figure 2.
TPD 011 – The
smallest turbo-
pump in the world.
Developed at
Pfeiffer Vacuum.

$$p_{\text{end}} = \sum(p_{\text{part, vv}}/K_{\text{max}})$$

Formula 1.

Flange

There are 3 different standardized flanges used in high vacuum technology:

The CF (ConFlat) flange connection is a symmetrical connection with a CU seal. It is used in ultra high vacuum technology ($p < 10^{-8}$ mbar) because of its low leak and desorption rates as well as its bake-out compatibility. The flanges are standardized (PNEUROP 6606, ISO 3669).

The ISO flange connection is a symmetrical flange connection with elastomer seal and supporting ring. The connection is made with clamping screws or union rings. These flanges are used for large nominal widths in the range 1000 to 10^7 mbar. The flanges are standardized (PNEUROP 6606, ISO 1609).

The KF small flange connection is a symmetrical flange connection with elastomer seal and supporting ring.

The mechanical connection is made with tension rings. Their application is in the rough to high vacuum range from 1000 to 10^{-7} mbar.

Flow

Vacuum systems are generally evacuated starting at atmospheric pressure. Different types of flow arise during evacuation depending on the ratio of the inner dimensions of the components of the system to the mean free path length of the flowing gas particles. Turbulent flows characterized by high Reynolds numbers generally, however do not arise. During evacuation, a laminar flow will typically arise first. As the pressure drops, Knudsen flow takes over, followed finally by molecular flow. The different types of flow do not arise suddenly and independently from one

another (Figure 3). Instead, one type of flow goes through a slow transition to another type of flow. The resulting phenomena can be ascertained mathematically, but the result is relatively complex formulas, especially when dealing with the Knudsen flow; the transition phase from laminar to molecular flow.

Flow conductance value

The flow conductance value (C) of an orifice, a pipe or a piece of a pipe between two defined cross-sections is defined in Formula 4. It is assumed that the temperature is in equilibrium throughout the system.

$$C = \frac{Q}{p_1 - p_2}$$

Formula 4.

The terms p_1 and p_2 are the pressures in the two cross-sections and Q is the gas flow. The result is in units of m^3/s or l/s .

Flow resistance

In most applications, the vacuum pump is connected through a pipe to the vacuum chamber. This pipe has a flow resistance which depends on the ratio of pressure Δp divided by gas flow Q. In the high vacuum and ultra-high vacuum range the flow resistance is independent of the pressure. The unit of flow resistance is s/m^3 , s/l^{-1} .

$$Q = \frac{p \cdot V}{t}$$

Formula 2.

Free path length

The mean free path length is the mean value of the path of a molecule between collisions with other molecules. It is in reverse proportion to the pressure (Table 1 on page 7).

1. Basic Principles and Definitions

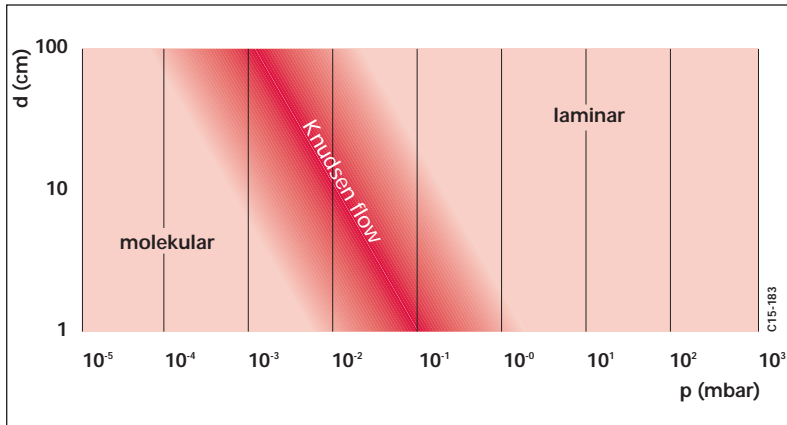

Figure 3. Representation of flow ranges dependent on pressure and line diameter.

G Gas load
The gas load or gas flow (Q) is the $\frac{p \cdot V}{t}$ throughput to a vacuum pump. It is measured in units of mbar l/s or sccm (standard cubic centimeters per minute). The standard conditions are 1013.25 mbar and 273.15 K. One mbar l/s = 55.18 sccm at 20°C.

H Holweck stage
A Holweck stage is a molecular pump stage with a smooth rotor and screw-shaped pump channels in the stator. In order to compress against high pressure, the dimensions of the pump channels have to be in the range of the mean path length (please see page 8) of the gas molecules. Maximum exhaust pressures of 20 mbar and higher are reached with the mechanically attainable gap dimensions.

I Intake pressure
The intake pressure (p_{HV}), also known as the high vacuum pressure, is the pressure on the high vacuum side of the turbopump (TMP), that is in the vacuum chamber.

M Molecular pumps
A molecular pump is a mechanical, kinetic vacuum pump that operates in the area of molecular flow (Figure 3). The collision of gas particles moving at high speed with the surface of the rotors

receives an impulse that promotes their movement in the direction of the fore-vacuum flange.

P Partial pressure
The partial pressure is the pressure of a certain type of gas or of a vapor in a mixture of gases and/or vapors.

Permeation
The permeation is the transportation of a gas through a solid body or liquid of finite thickness.

Pressure
The pressure of a gas on a boundary surface is the quotient of the normalized component of force placed on a section of the surface by the gas and the surface area of the section.

Pressure units
The standard units for pressure are the Pascal as the SI unit (Pa is the unit sign), and bar (bar is the unit sign) is a special unit name for 10^5 Pa.

$$1 \text{ Pa} = 1 \text{ Nm}^{-2}$$

$$1 \text{ bar} = 1000 \text{ mbar} = 10^5 \text{ Nm}^{-2} = 10^5 \text{ Pa}$$

Depending on the region, millibars (mbar), Pascals (Pa) or torr are used.

Pumping speed
The pumping speed S is the mean volume flow of the gas through the cross-section of the intake opening of a pump. The units of the pumping speed depend on the type of pump:

$$\text{m}^3/\text{s}, \text{ l/s}, \text{ m}^3/\text{h}$$

The standard unit is m^3/s . The units commonly used for turbopumps is l/s, however.

$$S = \frac{Q}{pHV}$$

Formula 3.

R Residual gas spectrum

A residual gas spectrum displays the composition, of gasses present in a chamber. This can help establish among other things, the purity of the generated vacuum. For example, the absence of oil vapor for turbopumps in high vacuum systems.

S Sorption

Selective take up of a material by another material that is in contact with it.

T Total pressure

The total pressure is the sum of the partial pressures of the gases or vapors present. The expression is used when the shorter expression "pressure" does not provide a clear differentiation between the individual partial pressures and their sum.

Turbopump

A turbopump is a molecular pump with rotors of turbinetype blades and pumping channels. The blades rotate between corresponding blades of the stator. The circumferential speed of the rotor is of the same order of magnitude as the mean particle speed of approximately 300-400 m/sec.

V Venting

Venting refers to the admission of gas into a vacuum apparatus or vacuum pump. When a turbopump is switched off, the rotor comes to a standstill and contamination on the fore-vacuum side (condensation) seeps back into the vacuum vessel and contaminates walls and objects. Contamination in the vacuum chamber is practically excluded by admitting dry gas into the turbopump. A minimum pressure between 10 and 1000 mbar should be attained with venting.



Figure 4. Rotary vane backing pump DUO 10 M from Pfeiffer Vacuum.

| Vacuum range | mbar | Particle density | Mean free path length (l) |
|-------------------|---------------------|--|---------------------------|
| Rough vacuum | 1000 – 1 | $2.5 \cdot 10^{25} - 2.5 \cdot 10^{22} \text{ m}^{-3}$ | $l \ll d$ |
| Medium vacuum | $1 - 10^{-3}$ | $2.5 \cdot 10^{22} - 2.5 \cdot 10^{19} \text{ m}^{-3}$ | $l \approx d$ |
| High vacuum | $10^{-3} - 10^{-7}$ | $2.5 \cdot 10^{19} - 2.5 \cdot 10^{15} \text{ m}^{-3}$ | $l > d$ |
| Ultra-high vacuum | $< 10^{-7}$ | $< 2.5 \cdot 10^{15} \text{ m}^{-3}$ | $l \gg d$ |

The particle densities are valid at a temperature of 20 °C.

d = pipe diameter

Table 1.

2. Turbopump Overview

2.1 The Principle

A particle that hits a moving orifice contains, after leaving the orifice, and in addition to its own thermal speed, a component in the direction of the movement

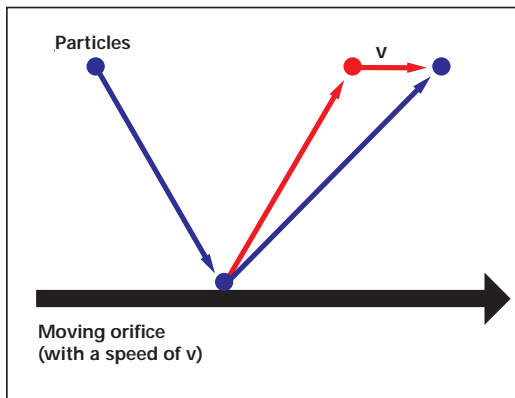

Figure 5. Principle of the molecular pump.

of the orifice. The overlaying of these two speeds yields a total speed and a direction in which the particle will move.

If a second orifice is positioned opposite the first orifice, the process is repeated. From the undirected thermal movement of the particle before the collision with the orifices, there now arises a directional movement, the pumping process.

Whereas the additional gas speed components in the molecular flow range contribute fully to the pumping effect, this is lost in the laminar flow range owing to the collisions with neighboring molecules. The transition range from the molecular to the laminar flow is in the range of 10^{-3} to 10^{-1} mbar. The mean free paths at 10^{-2} mbar correspond approximately to the distance between the blades on turbopumps. On account of the smaller channel cross sections on the Holweck stages, the transition range to laminar flow is approximately 1 mbar. Because the effect of the moving orifices on the gas particles is greatest in the molecular flow range, pumps that operate on this principle are called molecular pumps.

2.2 Design and Operation

2.2.1 Classical Turbopumps

On the basis of his experience with the first molecular pumps, in 1957 Becker designed a new molecular pump that was called the turbopump owing to the resemblance in its construction to a turbine. A turbopump essentially comprises

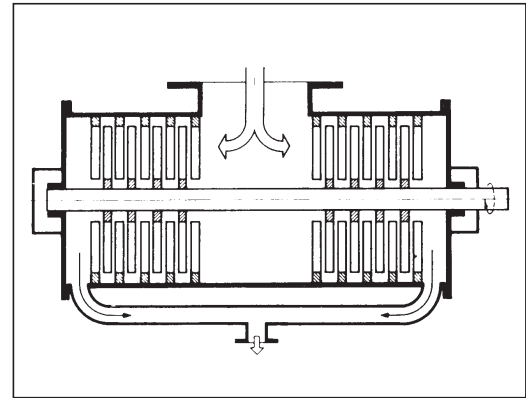

Figure 6. Schematic of a turbomolecular pump as designed by W. Becker.

a casing with a rotor and a stator. Rotating and fixed disks (or blades) are arranged alternately. All disks contain oblique channels whereby the rotor disk channels are arranged in mirror image to the channels on the stator disks. A rotor disk together with the stator disk forms a pump stage that generates a particular compression ratio that for air is approximately 30. The compression effect is multiplied by the sequential switching of several pump stages and very high ratios are attained (for example for air $> 10^{12}$).

2.2.2 Characteristics

The important vacuum data of a turbopump, the pumping speed and the compression ratio, depend on the version of the pump. As far as pumping speed S is concerned the following is valid: S is proportional to the intake flange (A) and approximately proportional to the rotation speed of the blades (v).

$$S \approx \frac{1}{4} A \cdot v$$

Formula 5.

In approximation and taking into account the inlet conductance value from the measuring dome and flange as well as an optimal blade angle of 45° the following formula provides the effective pumping speed S_{eff} of a turbopump for heavy gases (molecular weight >20):

$$\frac{1}{S_{\text{eff}}} \approx \frac{4}{A \cdot d_f} \left[\frac{1}{\bar{v}} + \frac{1}{\bar{u}} \left(1 + \frac{1}{2} \right) \right]$$

\bar{u} = mean thermal speed of the molecules

$\bar{u}_{N_2} = 470 \text{ m/s}$ (nitrogen)

d_f = amount of open surface on the turbo disk as a percentage of the total surface area (this is taken into account in Figure 7 with $d_f = 0.9$)

With the help of Figure 7 the pumping speed for a turbopump can be ascertained for N_2 .

a. Calculation of the blade base radius R_i and disk radius R_a and the pump rotation speed f .

b. The mean blade speed is then calculated:

$\bar{v} = f \cdot \pi \cdot (R_a + R_i)$ and the blade surface $A = \pi \cdot (R_a^2 - R_i^2)$.

c. The specific pumping speed is ascertained at position \bar{v} from the curve and this is multiplied with blade surface A .

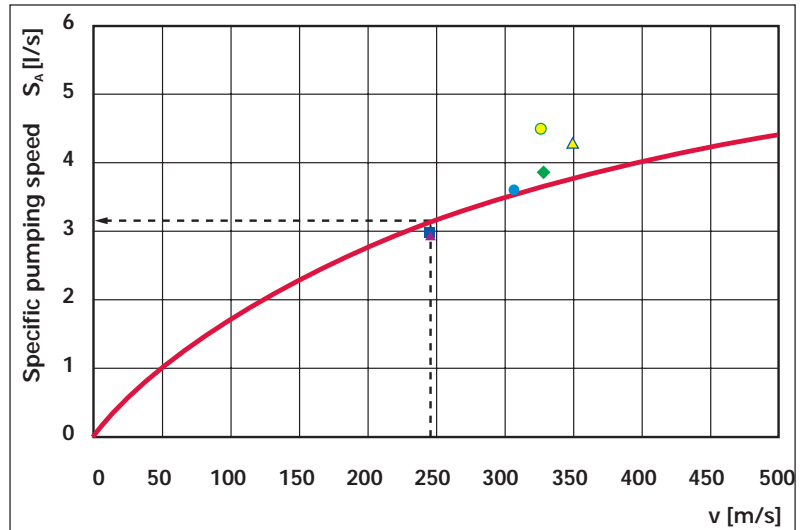

Figure 7. Specific pumping speed of a turbopump.

- Spec pumping speed
- TMH 071
- ▲ TMH 261
- ◆ TMH 521
- TMH 1001
- ▲ TMH 1601
- TPH 2101

Example TPH 261:

$R_i = 2.7 \text{ cm}$, $R_a = 5.2 \text{ cm}$, $f = 1000 \text{ Hz}$,
 $\bar{v} = 248 \text{ m/s}$, $A = 62 \text{ cm}^2$, $S_A = 3.21 \text{ l/s}$,
 $S_{\text{eff}} = 199 \text{ l/s}$

The dotted line is ascertained from the measurement values. The formula stated here only takes account of the pumping speed for the first pump stage.

The dependence of the pumping speed on the type of gas is represented in Figure 8.

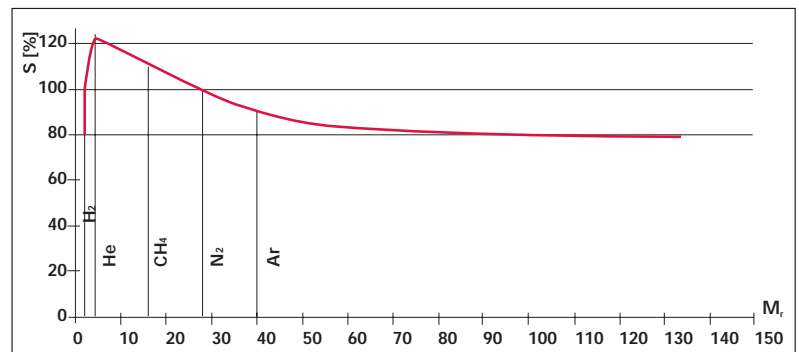

Figure 8. Pumping speed S as a function of the relative molecular mass M_r .

2. Turbopump Overview

In the molecular flow range, the pumping speed is independent of the pressure and reduces in the transition range to the laminar flow for the reasons given. A typical pumping speed in dependence on the intake pressure can be seen in Figure 10.

For the compression ratio the following is valid:

K_{\max} depends on the mean molecular speed, the proportion of the root from the molecular mass (M) is, as well as the blade speed (v). In this case the dependence is exponential.

$$K_{\max} \sim e^{\sqrt{M \cdot v}}$$

Formula 6.

Very high compression for heavy gases arises from the dependence of the compression ratio of the molecular mass. The compression breaks down very quickly on the transition from the molecular into the laminar flow range.

Therefore, a fore-vacuum pressure of < 0.1 mbar must be ensured in order to operate the classical turbopump. If the critical backing pressure is exceeded,

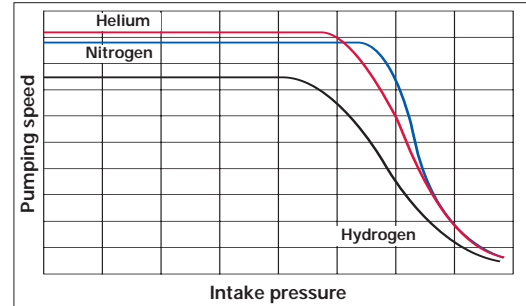

Figure 10. Pumping speed as a function of the pressure for various gases.

back streaming can cause shock penetration of the fore vacuum in the intake area of the pump.

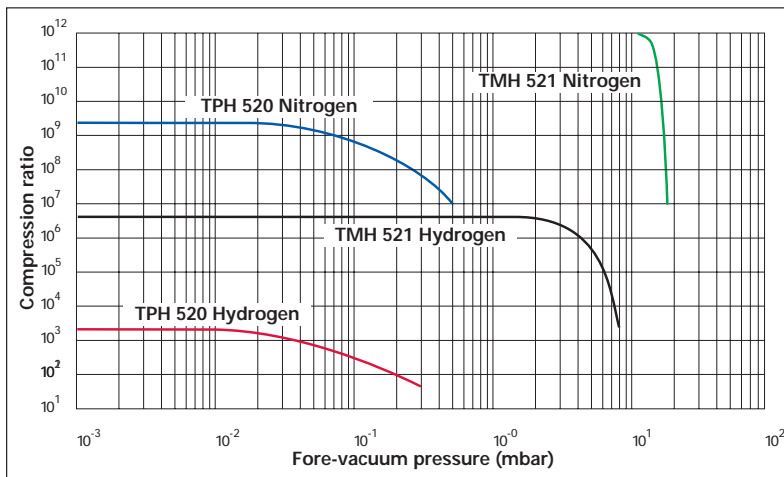

Figure 9. Comparison of the compression ratios of the classical turbopump (TPH 520) and the turbo drag pump (TMH 521).

2.2.3 CompactTurbo

There are different technical approaches used to improve the exhaust pressure of a turbopump. The approach we take at Pfeiffer Vacuum is to add a Holweck drag stage downstream of the turbo stage. This stage consists of a rotating cylinder and a stationary part with a thread. As with the turbomolecular stages, the Holweck stages are most effective in the molecular flow range. The typical dimensions of a pump channel on the Holweck stage is smaller than on the turbo disks by a factor of 10 to 50. Molecule collisions attain significance only at higher pressures. The molecular flow is therefore retained up to a few mbars. The pumping speed of Holweck stages is,

compared with the pumping speed for a turbomolecular stage, less because only a relatively small entry surface can be utilized. In turbo drag pumps, the gas molecules already compressed by the turbopump stages are easily accepted by the downstream Holweck stages with reduced pumping speeds, where they are further compressed and then pumped to the backing pump (see Fig. 12). Placing concentric Holweck stages in parallel (please see Figure 9) allows the pumping speed to be increased at high pressures while reducing the heat build-up.

This is especially advantageous when pumping high gas loads. The Holweck stages, therefore, represent an integrated large backing pump that can expel against approximately 10 mbar.

Advantages:

- Enables the use of dry backing pumps, particularly diaphragm pumps with final pressures of 2 to 5 mbar.
- The required backing pumps for gas load operations are significantly smaller.



Figure 11. Turbomolecular Drag Pumps with integrated drive unit.

Example: Classical turbopump with gas load 1 mbar l/s, required fore-vacuum pressure 0.1 mbar in accordance with formula 3:

$$S_{VP} = \frac{Q}{p} = \frac{1 \text{ [mbar} \cdot \text{l/s]}}{0.1 \text{ [mbar]}}$$

$$= 10 \text{ [l/s]} = 36 \text{ [m}^3\text{/h]}$$

Here, a backing pump with a pumping speed of at least 36 m³/h is required.

Turbo drag pump with gas load 1 mbar l/s, required fore-vacuum pressure 5 mbar in accordance with formula 3:

$$S_{VP} = \frac{Q}{p} = \frac{1 \text{ [mbar} \cdot \text{l/s]}}{5 \text{ [mbar]}}$$

$$= 0.2 \text{ [l/s]} = 0.72 \text{ [m}^3\text{/h]}$$

In this case a backing pump with 1 m³/h is adequate for the operation.

2. Turbopump Overview

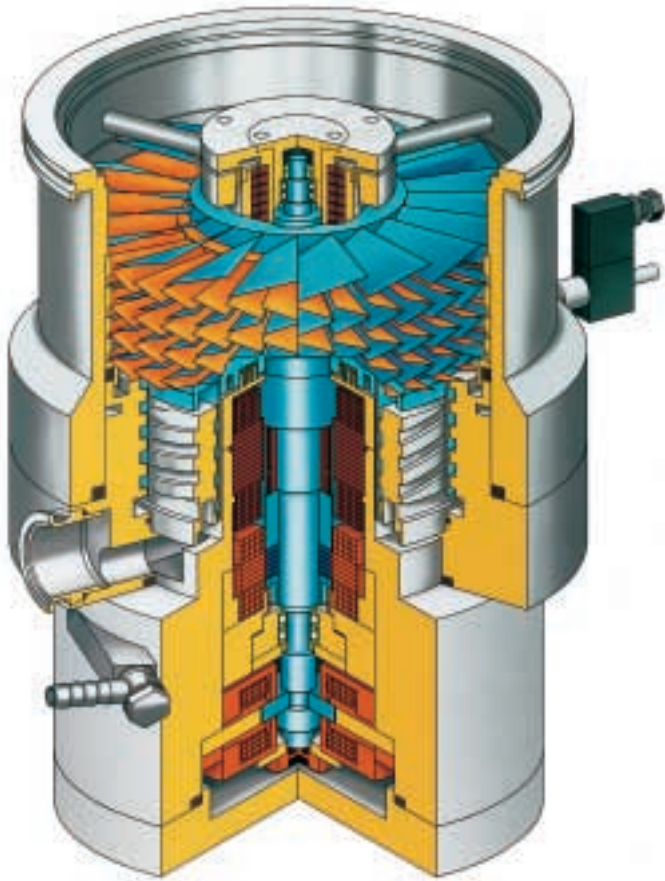

Figure 12. Cross section, MagneticTurbo with Holweck stage.



Figure 13. MagneticTurbo 200 to 1600 l/s.

2.2.4 MagneticTurbo

Our standard turbopumps are normally equipped on the fore-vacuum side with lubricated ceramic ball bearings and on the high vacuum side with a passive, radially stabilizing maintenance-free permanent magnetic bearing. Turbopumps fully equipped with magnetic bearings have been designed for special applications. Fully magnetic bearing turbopumps have been designed for special applications. Electromagnets are used to hold the rotor electronically suspended in the axial direction. The radial position can be regulated either via the permanent magnetic bearing or also electronically. Because there is no direct contact of the rotor with the casing, the vibration level is extremely low. Additionally, out of balance compensation takes place and this reduces the vibration level even further; it is less than for comparable ball bearing turbopumps by approximately an order of magnitude of one. A further advantage besides the absence of oil on the fore-vacuum side is the reduced wear and tear and the freedom of maintenance. In the event of a power failure, the magnetic bearing is supplied with power by the energy from the rotor. This ensures continuation of power supply for approximately 7 minutes. Where longer interruptions to the power supply are involved, the rotor is brought to a standstill at approximately 20 % of the rated rotation speed via an integrated safety bearing. Even when the electronics malfunction, ingress of air, or earthquakes, the rotor is brought to rest many times without venting and without damage. Any mounting position can be selected for magnetic bearing turbopumps in turbo drag and normal turbo-technology.

2.2.5 CorrosiveTurbo

Certain measures are necessary where the pumping of corrosive gases are involved and these are designed especially to protect the bearing area and the rotor against corrosion. All surfaces that come into contact with gas are provided with a coating (or are manufactured from special materials) which resist the attacks from corrosive gases. The penetration of corrosive media into the motor room and – with rotors with non-magnetic bearings, the bearing area – is prevented by the admission of an inert gas (sealing gas). For this, a special sealing gas valve that admits a defined gas stream into the motor room is fitted to the turbopump.

A dynamic seal is created using suitable design measures that reduces the amount of sealing gas needed. The sealing gas, together with the corrosive gas, is pumped out of the system via the backing pump. If the process generates condensable vapors, for example aluminum chloride Al_2Cl_6 , there is the danger of condensation in the pumping system. In order to prevent this, all surfaces that come into contact with the gas have to be heated. The temperature management system (TMS) serves to regulate the temperature of the internal surfaces of the turbopump to values that are adjustable. Knowledge of the vapor pressure curve of the condensable gas, the condensation and the resulting damage and the effect on the vacuum channels can be prevented.



Figure 14. CorrosiveTurbo with integrated drive for corrosive gas operations and process technology.

3. Operating Turbopumps

3.1 Electronic Drive Units

The rotor of every turbopump must be driven and controlled. This is done using electronic drives that are either integrated into the turbopump or form a separate unit depending on the design of the turbopump.

3.1.1 TC 100, 600 and 750 for Conventional Turbopumps

Turbopumps are driven by the TC 100, 600 or 750 Electronic Drive Unit. These units regulate the motor during the start up phase and also the necessary drive power once the desired rotation speed has been attained. The TC series has been designed as a sensorless DC drive and is constructed in modular form. The electronic drive unit is an integral part of the pump and can be augmented by the addition of accessories depending on the requirements. Apart from the regulation of the

motor, the unit has many other functions and parameters. Here is an abbreviated list of the more important options

- On/Off
- Optional rotation speed
- Venting valve control
- Heating control
- Backing pump control
- Air cooling control
- Pre-selection stand-by rotation speed
- Operating hours counter
- Backing pump intermittent operations
- Display: rotation speed, power consumption and the operating modes for various gases
- RS-485 serial interface for PC and bus control
- Remote control etc.



Figure 15.
Drive Unit Concept
TC 100 with
accessories.

In the TC series, the smallest unit capable of operation consists of a turbopump and an electronic drive unit. A TCK 100 print card for easy integration into a system is available and an alternative for pumps with a 24-VDC-drive. A power supply (24–140 V depending on the pump type) and a cooling unit (air-cooled or water-cooled) are required. Optional extras include an operating and display unit (DCU) for all turbopump control options and which also shows the parameters, venting valve, heating with switching relay, relay for the backing pump control and the sealing gas valve. DCU and power pack units are also available as rack insert units.

3.1.2 TCP 350 as a Separate Drive Unit

For the CompactTurbo pumps of the size 071-521, a separate drive unit is available as an alternative. This drive may be suitable for applications, where pumps are exposed to high radiation levels, or where the plant does not provide sufficient space for the turbos with integrated drive. The TCP 350 combines drive unit, power unit, display and controller in a single compact instrument. Parametrization is identical to the integrated TC versions and offers extended remote control functions.



Figure 16. TCP 350.



Figure 17. TCM 1601.

3.1.3 TCM 1601 for Magnetic Bearing Turbopumps

Turbopumps with the magnetic rotor system are driven via the Electronic Drive Unit TCM 1601 which comprises the components drive, magnetic bearing and integrated power pack unit. The electronic drive unit is fitted as standard with LC display, operating keys, serial interface RS-485, plug connection for the remote control (SPS compatible) plug connection for the Pumping Station Control Unit TCS 180, plug connection for the potential free relay contacts and plug connection for the battery box. The turbopump is connected to the electronic drive unit via a cable. The unit regulates the control of the motor and the magnetic bearing of the rotor. Magnetic bearing turbopumps are fitted with direct current motors with three phase Hall IC drive. Positional identification of the magnetic bearing rotor is via eddy current sensors in X, Y and Z direction. Turbopumps connected to the TCM 1601 are equipped with a three-axis active magnetic bearing. In addition to the pure motor control and the magnetic bearing, the functions and parameters of the controller are similar to those of the TC 600. The operating parameters can be modified and optional accessories can be

3. Operating Turbopumps

used depending on the application (chapter 3.2 ff.).

Further modules can be connected to the electronic drive unit as follows:

TCS 180

Extension module for the control of a pumping station with backing pump and fore-vacuum safety valve, high vacuum valve and diverse pressure gauges.

Battery box

Battery box TBB supplies power to the magnetic bearing up to standstill of the rotor.

3.1.4 Serial Interface

The electronic drive units from Pfeiffer are equipped with an RS-485 serial interface implementing the Pfeiffer protocol. Field bus converters for the Profibus and other systems are available on request. There is an RS-485 to RS-232 interface converter available to operate the device with a PC.

3.2 Standby-Operations

Standby-operation at a rotation speed of 67 % of the rated rotation speed makes sense when the total pumping speed and full compression of the turbopump is not required. This reduced rotation speed results in longer bearing life spans owing to the reduction in wear and tear.

Application cases:

- To retain vacuum during longer interruptions, for example holidays, weekends.
- For experiments and measurements in the higher pressure range.
- On attainment/non-attainment of the required final vacuum.

3.3 Rotation Speed Setting Mode

If a particular process pressure is required for a process gas volume, for example, expensive throttle valves are unnecessary if the pumping speed of the turbopump can be regulated via the rotation speed. A further application is the reduction of the rotation speed with high-level gas loads to avoid the turbopump having to operate continuously at its capacity limits.

3.4 Operating Modes for Various Gas Types

The molecular friction associated with high-level gas loads causes heating of the rotor. For protection purposes, the power from the motor is limited. For example, for heavy noble gases, all of which possess a low specific thermal capacity and transmit therefore, little heat from the rotor to the pump casing, the critical rotor temperature is attained with less power than when pumping polyatomic gases. There are different output levels (gas mode 0 and 1) programmed in the TCM, TC, TCK and TCP

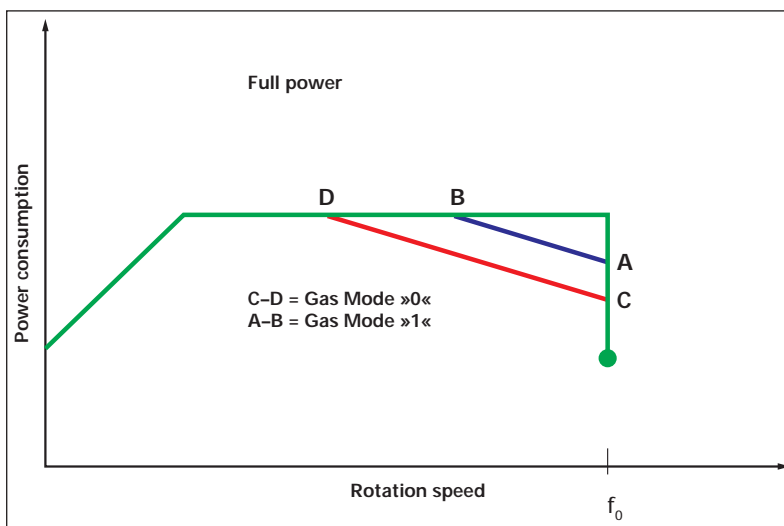

Figure 18. Characteristic lines for various gas types.

electronic drive units for noble gases (Ar, Xe, Kr). The output levels are automatically assigned to the corresponding pump types (Fig. 18). The operating mode is to be selected based on the type of gas used. The mode you have set is also taken into account when in the rotation speed setting mode.

3.5 Heating

To attain a lower final pressure, turbopumps can be fitted with a heating unit. By heating the pump up to 120 °C, the metal surfaces on the rotor, stator and casing parts are de-gasified and within a short time a lower pressure is attained. A CF flange connection with a metal seal is advantageous. By connecting an electronic drive unit the heating is only activated when a specified pump rotation speed is attained. The maximum permissible rotor temperature of the pump is 120 °C if the vacuum chamber is heated or if parts in the vacuum chamber are subjected to high level temperatures, the heat radiated into the pump must not exceed the values stated in the technical data. If necessary, suitable heat shields should be fitted in the vacuum chamber.

3.6 Venting

After a shutdown without venting resulting from pressure equalization, residues from the fore-vacuum gas (condensate) contaminate the turbopump. By venting the turbopump with dry venting gas, the level of contamination is reduced due to the slower rate of diffusion. In order to achieve short pumping times, dry venting gas should be used to vent the turbopump after it has been switched off or no later than after reaching 20% of the rated rotation speed. The venting valve controlled by the electronic drive units is preferred for venting purposes. The venting frequen-

cy and venting duration can be specified according to the requirements. Venting can be performed manually via a venting screw (only for the CompactTurbo). The venting connection patented by Pfeiffer Vacuum directs the venting gas into the compression stages. The gas admitted distributes itself equally between the high vacuum and fore-vacuum sides. The venting gas must not be admitted on the fore-vacuum side, otherwise the hydrocarbons in the fore-vacuum channel will be transported to the high vacuum side.

3.7 Vibrations

3.7.1 Frequency Analyses

During the universal quality control check, frequency analyses are carried out for all turbopumps to evaluate all dynamic modules (see the data lists on pages 38–41)

3.7.2 Anti-vibration Unit

There are anti-vibration units available as accessories when anti-vibration measures are required in spite of the very low vibration amplitudes of Pfeiffer Vacuum turbopumps. They can be used whenever turbopumps are used with systems sensitive to vibrations such as electron microscopes, microsensors and various analysis instruments. When used in these types of applications, direct mechanical connection to components with higher vibration amplitudes (such as the backing pump) is to be avoided. The vibration amplitudes are damped by a factor of approximately 10 with respect to the usual turbopump frequencies.

3. Operating Turbopumps

3.8 Magnetic Fields

For turbopumps, we differentiate between:

- external magnetic fields that affect the pump and
- magnetic leakage fields originating in the turbopump.

3.8.1 Turbopumps in Magnetic Fields

Static or temporary magnetic fields generate eddy currents in the rotor of a turbopump that heat up the turbopump. On the basis of the increase in current/power consumption it can be determined whether a magnetic field is given permissible.

Normally the limit values are a few millitesla. The precise values can be found in the operating instructions.

If operations are conducted in more intensive magnetic fields, the turbopump must be shielded. For magnetic fields vertically oriented to the rotor shaft, cylindrical shielding of steel plate (St 37) can be used. For fields of < 5 mT in the interior of the shielding cylinder, the wall strength can be calculated using the following formula:

$$d = D \cdot \frac{B_a}{B_s}$$

Formula 7.

D = cylinder diameter

d = wall strength

B_a = field to be shielded against

B_s = saturation induction (for St 37: 1.6 T)

Where pulsed magnetic fields are involved, the maximum permissible field strength is calculated as follows:

$$B_{\max \text{ pulsed}} = \sqrt{\frac{t_1 + t_2}{t_1}} \cdot B_{\max}$$

Formula 8.

Whereby B_{max} is the permissible field strength for the turbopump involved, t₁ is the time that the magnetic field exists and t₂ is the time during which the magnetic field is absent (see the data lists on page 36).

3.8.2 Magnetic Fields of Turbopumps

Turbopumps create magnetic fields that are generated by the motor and by the permanent magnetic bearing. There is a static proportion as well as a proportion of the pulsating field that in good approximation is a sine wave with the frequency of the pump rotation speed.

3.9 Safety

At Pfeiffer Vacuum the safety elements are always designed according to the state-of-the-art and are proven in a variety of crash tests.

3.9.1 Operational Safety of the Turbopump

Turbopumps are protected against damage arising from malfunctions or from improper operation by a whole range of features including:

- **Temperature Monitoring:** the lower parts and motors of the turbopump are fitted with temperature sensors that reduce the motor power in the event of exceeding the limit value.
- **Gas Load Monitoring:** at final rotation speed, only a specific power is transmitted to the turbopump in order to avoid rotor overheating. Because the power limit is dependent on the type of gas, various gas modes are available for selection.
- **Protection against ingress of air:** the pumps are fitted with safety bearings which, for example, in the event of a sudden inrush of air, safely bring the rotors to a standstill. However, the degree of wear on the safety bearing is very high and, therefore, these situations should be regarded as exceptional.
- **Protection against foreign particles:** splinter shields and grills are available as accessories and are fitted to the high vacuum side to protect against foreign bodies. However, depending on the version, the pumping speed can be reduced by up to 5–20 %.

Figure 19:
HiMag™ 2400,
magnetically
levitated turbo-
molecular pump
with special
safety concept.

3.9.2 Safety for Operating Personnel

In the event of a rotor/stator crash (the worst imaginable type of malfunction) the energy of rotation on the rotor is transmitted to the casing within milliseconds. This causes high centrifugal forces that have to be absorbed by the frame of the apparatus. The casing and securing elements have been designed so that parts from the interior of the pump cannot penetrate through the casing or (in proper constructions) the securing elements break up. This has been taken into account in the design and proved in crash tests. During installation work the safety instructions must be followed (the number of screws, screw quality)!



4. Applying and Dimensioning Turbopumps

4.1 The most Important Parameters

In this chapter, information is imparted on what influences must be taken into account with regard to specific applications. In addition, basic principles are covered which will help in understanding the dimensioning of vacuum systems for a specific process and enable users to make their own calculations.

The selection criteria should always be clarified and defined before specifying the dimensions of a pump combination. The following table can help you to form the basis for successful dimensioning:

In the following formula and calculation examples, exclusively SI base units and the derived SI units with the number factor 1 are used. In addition to the numerical value of the measurement, its unit has also to be inserted. For ease of reference, the units are displayed in rectangular brackets.

It is recommended that only after completion of the calculation the results are converted into other units (please also see page 30).

| Questions on the system | Units | Questions on the turbopump | Units |
|--------------------------------|----------------|----------------------------|-----------------|
| Volumes | m ³ | Pumping speed | l/s |
| Surfaces and materials | m ² | Rated pumping speed | l/s |
| Gas load / gas throughput | mbar l/s | Effective pumping speed | l/s |
| Gas type | | Conductance value loss | l/s |
| Gas composition | | Gas throughput | mbar l/s |
| Condensation probability | | Maximum output power | W |
| Aggressivity | | Maximum rotational speed | S ⁻¹ |
| Reaction products | | Thermal limits | °K |
| Process pressure | mbar | Compression | |
| Base pressure | mbar | Partial pressures | mbar |
| Other factors of influence | | Final pressure | |
| Magnetic field | mT | System influences | |
| Radiation | rad | Pumping time | |
| Thermal influences | °K | Backing pump | |
| Mounting positions | | High vacuum pump | |
| Existing peripheral subsystems | | | |

4.2 Applications without Process Gas

In principle, when working with high vacuum it is necessary to take note of the cleanliness, of the surfaces of the vacuum vessel and the turbopump.

For example: a vacuum vessel contains an oil patch of 0.1 g mass (relative molecular mass = 200).

What gas flow (Q) is produced with a temperature of 300 K when it is assumed that the oil vaporizes evenly within a day (t)? What does this mean for the attainable final vacuum in this time when a turbopump with a pumping speed of 70 l/s is in operation? Number of molecules (N) in 0.1 g oil (mass M):

$$N = \frac{m}{m_r \cdot u}$$

Formula 9.

m = mass

u = atomic mass unit

m_r = relative molecular mass

$$N = \frac{10^{-4} \text{ [kg]}}{200 \cdot 1.66 \cdot 10^{-27} \text{ [kg]}} = 3.0 \cdot 10^{20}$$

$$p \cdot V = N \cdot k \cdot T$$

Formula 10.

k = 1.38 · 10⁻²³ Nm/K (Boltzmann-constant)

T = 300K

$$\begin{aligned} p \cdot V &= 3.0 \cdot 10^{20} \cdot 1.38 \cdot 10^{-23} \text{ [Nm/K]} \cdot 300 \text{ [K]} \\ &= 1.24 \text{ Nm} \\ &= 1.24 \frac{\text{N}}{\text{m}^2} \cdot \text{m}^3 \\ &= 1.24 \text{ Pa} \cdot \text{m}^3 \\ &= 12.4 \text{ mbar} \cdot \text{l} \end{aligned}$$

The gas flow Q in mbar · l/s is therefore, according to formula 2:

$$\begin{aligned} Q &= \frac{12.4 \text{ [mbar} \cdot \text{l]}}{86400 \text{ [s}^2\text{]}} \\ &= 1.43 \cdot 10^{-4} \text{ mbar} \cdot \text{l/s} \end{aligned}$$

With a 70 l/s TMP there results the pressure to p = Q/S = 2.1 · 10⁻⁶ mbar.

In this example and without any further gas flow, no vacuum better than 2.1 · 10⁻⁶ mbar can be attained on the first day. However, as a rule the vaporization of impurities does not proceed evenly but reduces with the passing of time (see below). A relatively small amount of contamination can, therefore, prevent the attainment of the required final vacuum for a relatively long time.

4.2.1 Pumping Curves

What amount of time is required to evacuate a vacuum vessel to a specific pressure level with the stated configuration?

A sufficient vacuum must first be created with the help of the fore-vacuum pump before the turbopump reaches its full rotation speed (and therefore its full pumping speed). The pressure in this vacuum can be 0.1 – 5 mbar depending on the turbopump concept (see chapter 2.2). This time is dependent on the pumping speed of the backing pump and the volume of the vacuum vessel. For the pressure in dependence on the time, the following is valid:

$$p(t) = p_0 \cdot e^{-\frac{S_v}{V} \cdot t}$$

Formula 11.

Whereby p₀ is the pressure at the time t = 0, S_v the effective pumping speed of the backing pump which, owing to losses in the piping is always smaller or equal to

4. Applying and Dimensioning Turbopumps

the rated pumping speed (see chapter 5) and V the volume of the vessel.

In terms of time, the following relationship is obtained:

$$t_1 = \frac{V}{S_V} \cdot \ln \frac{p_0}{p_V}$$

Formula 12.

t_1 here refers to the time up to the attainment of final vacuum when p_0 is the starting pressure (normally atmospheric pressure) and p_V the starting pressure of the turbopump (approximately 0.1 mbar). After this rough evacuation, the turbopump begins to work according to the formula:

$$t_2 = \frac{V}{S_{TMP}} \cdot \ln \frac{p_V}{p_e}$$

Formula 13.

S_{TMP} is the effective volume flow rate of the turbopump, p_e is the required final vacuum. The time taken to attain final vacuum is therefore:

$$t_{tot} = t_1 + t_2$$

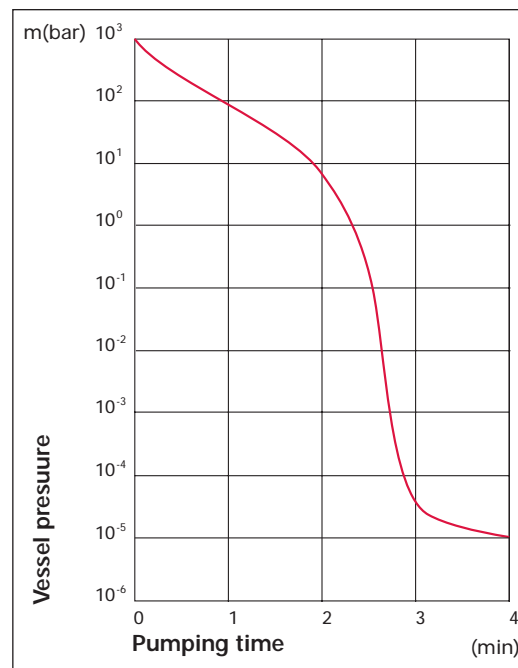

Figure 20.
Pumping curve
(20 liter vessel)
TMH 071 with a
diaphragm backing
pump MD 4.

These formulas represent an estimate because the pumping speed of the backing pump and of the turbopump is not constant over the entire pressure range. Furthermore, the calculation is only valid for a final vacuum of up to approximately 10⁻⁴ mbar or even lower pressures when the vacuum vessel is extremely clean due to the exhaust gas effects described. Nevertheless, it helps to calculate the pumping speed needed for the backing pump and turbopump when certain requirements are placed on the pumping time. Figure 20 shows a typical pumping curve. The calculation of losses in the connecting lines is necessary when bottlenecks (connections with smaller diameters than the flanges used or very long connections) are involved. In these cases there can be considerable discrepancies between the effective pumping speed and the rated pumping speed. Figure 18 illustrates a typical pumping curve. Where lower pressure ranges are involved, leaks and desorption gas streams must be taken into account.

Q_{Leak} : The gas flow is dependent on leaks in the vacuum system. It is independent of time and prevents undershooting of a pressure which leads, according to formula 3, to

$$p_{GL} = Q_{Leak} / S_{TMP}$$

A system is considered sufficiently leak tight when the equilibrium pressure p_{GL} is about 10 % of the working pressure. If, for example, a working pressure of 10⁻⁶ mbar is to be attained and the turbopump has a pumping speed of 100 l/s, then the leak rate should not be greater than 10⁻⁵ mbar l/s. This represents a leak rate for a leak approximately 20 by 20 μm^2 in size. Leak rates of < 10⁻⁸ mbar l/s are generally attainable.

$Q_{\text{des,M}}$: The gas molecules which bond on the internal surfaces of the vacuum chamber as a result of adsorption and absorption (mainly water) gradually invade the volume under vacuum. The desorption rate of the metal and glass surfaces in the vacuum system leads to the incidence of gas which is time dependent. It can be assumed as a good approximation that the diminution from a time point $t > t_0$ is linear with the time. Typically t_0 is taken as 1 h.

The incidence of gas can be described as

$$Q_{\text{des,M}} = q_{\text{des,M}} \cdot A \cdot \frac{t_0}{t}$$

Formula 14.

Here, $q_{\text{des,M}}$ is the desorption rate of the surface of the material (see Chapter 7, Desorption rates), A is the internal surface area of the vacuum vessel, t_0 is the start time and t is the time. It is now possible using Formulas 2 and 14 to calculate the time required to attain the desired working pressure after readjustment:

$$t_3 = \frac{q_{\text{des,M}} \cdot A \cdot t_0}{S \cdot p_{\text{work}}}$$

Formula 15.

The formula pre-supposes that the working pressure is large compared with the theoretical final pressure of the turbopump. For constant gas flows such as leaks, for example, Formula 15 needs to be expanded:

$$t_3 = \frac{q_{\text{des,M}} \cdot A \cdot t_0}{S \cdot (p_{\text{work}} - p_{\text{end}}) - Q_{\text{const}}}$$

Formula 15a.

Whereby p_{end} is the theoretical final pressure of the turbopump according to chapter 1, formula 1 and Q_{const} is the sum of all constant gas streams.

Because free desorption only begins after rough evacuation of the vacuum vessel, the total time up to attainment of the working pressure taking account of the desorption of metallic surfaces is

$$t_{\text{tot}} = t_1 + t_2 + t_3.$$

Example:

A vacuum vessel of volume 1 m^3 and an internal surface of 6 m^2 should be evacuated to 10^{-6} mbar with the assistance of a backing pump with a pumping speed of $16 \text{ m}^3/\text{h}$ and a turbopump with a pumping speed of 200 l/s . The vacuum vessel material is a cleaned stainless steel with polished surfaces. Leaks are negligible. What times t_1 , t_2 , t_3 and t_{ges} are involved?

In accordance with formula 12

$$\begin{aligned} t_1 &= \frac{V}{S_V} \cdot \ln \frac{p_0}{p_V} \\ &= \frac{1 \text{ [m}^3\text{]}}{16 \text{ [m}^3\text{/h]}} \cdot \ln \frac{1013 \text{ [mbar]}}{0.1 \text{ [mbar]}} \\ &= \mathbf{0.58 \text{ h} = 35 \text{ min}} \end{aligned}$$

In accordance with formula 13

$$\begin{aligned} t_2 &= \frac{V}{S_{\text{TMP}}} \cdot \ln \frac{p_V}{p_e} \\ &= \frac{1000 \text{ [l]}}{200 \text{ [l/s]}} \cdot \ln \frac{0,1 \text{ [mbar]}}{10^{-4} \text{ [mbar]}} \\ &= \mathbf{34,5 \text{ s} = 0,6 \text{ min}} \end{aligned}$$

In accordance with formula 15 with

$$q_{\text{des,M}} = 2 \cdot 10^{-8} \frac{\text{mbar l}}{\text{s cm}^2} \text{ (bei } t_0 = 1\text{h)}$$

(see Chapter 7, Desorption rates)

$$\begin{aligned} t_3 &= \frac{q_{\text{des,M}} \cdot A \cdot t_0}{S_{\text{TMP}} \cdot p_{\text{work}}} \\ &= \frac{2 \cdot 10^{-8} \text{ [mbar} \cdot \text{l/s} \cdot \text{cm}^2\text{]} \cdot 6 \cdot 10^4 \text{ [cm}^2\text{]} \cdot 1 \text{ [h]}}{200 \text{ [l/s]} \cdot 10^{-6} \text{ [mbar]}} \\ &= \mathbf{6 \text{ h} = 360 \text{ min}} \end{aligned}$$

The total time is, therefore, approximately 400 minutes. The inter-relationship of the times is typical for the evacuation of

4. Applying and Dimensioning Turbopumps

vessels. Whereas, the backing pump requires significant time to generate the start pressure for the turbopump, owing to its high level pumping speed the turbopump evacuates rapidly to 10^{-4} mbar. The longest time period, however, is required for the generation of vacuum less than 10^{-4} mbar. The progress corresponds to the pumping curve illustrated in Figure 20.

A relatively precise calculation of the times t_1 and t_2 is possible, but the time t_3 depends strongly on the properties of the surface and the desorption rate of the vacuum vessel.

4.2.2 Pressure Range from 10^{-6} to 10^{-8} mbar

Various measures are required in order to attain the pressure range below 10^{-6} mbar within an acceptable time.

1. Baking out (see 4.2.3.1)
2. Venting with dry venting gas

When the system is shut down, it should be vented with a dry venting gas (nitrogen, for example). This prevents water molecules from the air in the environment from settling on the walls that are difficult to desorb on account of their adhesive force. The venting gas adsorbs on the internal surfaces and desorbs very efficiently when the system is restarted so that the pumping times are significantly reduced.

When operating under 10^{-6} mbar, desorption from synthetic surfaces, especially from the seals, gains greater significance. The surfaces of the seals are relatively small but the reduction in the desorption rate over time is less favorable than for metallic surfaces. It can be assumed, in approximation, that the reduction over time is not linear with respect to the time but only with respect to the root of the time. This difference arises because synthetic materials mainly give off those gases released within them and which

must then diffuse to the surface. After pumping for a long time, the desorption from synthetic materials can dominate over that from metallic surfaces.

$$Q_{\text{des.K}} = q_{\text{des.K}} \cdot A \cdot \sqrt{\frac{t_0}{t}}$$

Formula 16.

Whereby A is the surface of the synthetic material in the vacuum vessel and $q_{\text{des.K}}$ is the surface specific desorption rate for the respective synthetic material, the calculation of the respective pressures and pumping times is performed analogically to the example shown on page 22.

A further process that can lead to the incidence of gas must be taken into account in this pressure range: the gas permeation from walls and seals.

Molecules of gas can penetrate the structure (particularly the seals) from outside and diffuse in the vacuum vessel. This process is time independent and leads, therefore to a lasting increase in the final pressure attained. The permeation gas stream is dependent on the pressure gradient p/x (x = wall thickness, p = external pressure, generally atmosphere), the extent of the surface of the synthetic material and the permeation constant k_{Perm} of the material in use:

$$Q_{\text{Perm}} = k_{\text{Perm}} \cdot \frac{p}{x} \cdot A$$

Formula 17.

With the help of the permeation constants shown in the appendix (chapter 7 permeation constants), it can be estimated whether permeation should be taken into account for the given configuration.

4.2.3 Pressure Range below 10^{-8} mbar

The following pre-conditions are involved when operations are involved in this pressure range:

- The turbopump must possess the required compression ratio for the final pressure involved.
- Metal seals (CF flange connections) are necessary.
- Pump and apparatus must be baked out.
- Leaks must be avoided and eliminated before switching on the heating (use helium leak detectors!).
- Clean conditions are necessary which means that all surfaces have to be properly cleaned and that grease-free gloves are used in the assembly process.
- Dry venting gas should be used for ventilation.

4.2.3.1 Baking out

After assembly, the apparatus is switched on and once the final rotation speed is attained, both the pump and the vacuum chamber are heated. During heating, all vacuum gauges should be in operation and degassed in time intervals of 10 hours. In order to attain the pressure range of 10^{-10} mbar, a bake-out temperature of 120°C and a heating time of approximately 48 hours under the use of stainless steel vessels and metallic seals is adequate. Baking out should continue until a hundred times the required final pressure is attained at which time the pump and vacuum chamber heating is switched off. After cooling, it is probable that the required final pressure is attained. Where pressures of $< 5 \cdot 10^{-10}$ mbar and large area internal surfaces are involved the use of titanium sublimation pumps – which pump the hydrogen emerging from the metal with high level volume flow rates – is advantageous.

4.2.3.2 Residual gas spectrum

When working in ultra high vacuum, the composition of the residual gas in the vacuum chamber can be of significance. On account of the low relative molecular mass ($M = 2$) of hydrogen the pressure ratio of the turbopump, is lowest for this gas. With knowledge of the respective partial pressure of hydrogen in fore-vacuum, the proportion of this gas in the residual gas can be ascertained. For the most part, this proportion is dominant in relation to other gases. With unclean or unbaked out vacuum chambers, the proportion of water and fragments of HO is large. Leaks are perceptible through the presence of peaks of nitrogen ($M = 28$) and oxygen ($M = 32$) (ratio $\text{N}_2/\text{O}_2 \sim 4/1$). Carbon monoxide CO also appears with $M = 28$ and is not, therefore, easily separated from nitrogen, carbon dioxide at 44. Heavier gases, for example, molecules of the backing pump oil or their fragments can be very effectively kept away from the chamber because of the high molecular mass and the resulting high compression rates. A typical residual gas spectrum in a clean vacuum vessel evacuated by a turbopump is shown in Figure 21.

Figure 21:
Typical residual gas spectrum of a turbopump.

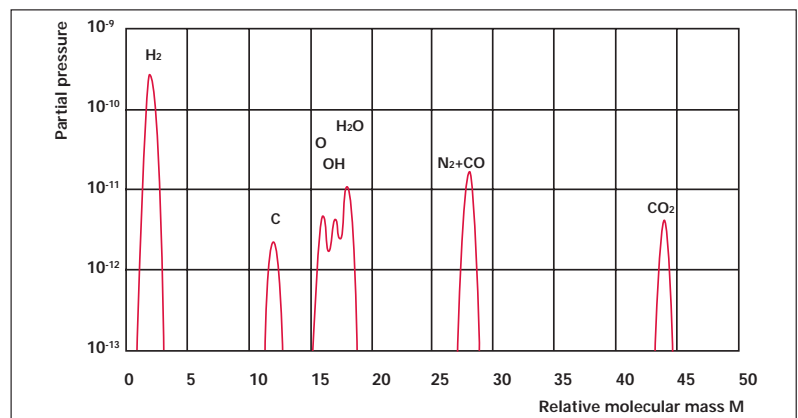

4. Applying and Dimensioning Turbopumps

4.3 Applications with Process Gas

4.3.1 Low Gas Loads < 0.1 mbar l/s

When operating with process gas, the generation of the cleanest possible vacuum is not of prime importance but rather the maintenance of that specific pressure which is necessary for the process (Fig 20). The following results are for the equilibrium pressure P_{GL} in the vacuum chamber from Formula 3:

$$P_{GL} = \frac{Q_{process}}{S_{eff}}$$

With the low gas loads involved here, the calculated equilibrium pressure is still less than 10^{-3} mbar even with a small turbopump. Therefore S_{eff} (providing there is no loss in the connecting lines, see Chapter 5) is the stated pumping speed of the turbopump in the molecular range. The smallest possible pump for the process can be determined from this formula by using the stated rated pumping speed in the technical data. There are various options if from time to time higher pressures are required:

- The fitting of a regulating valve between the turbopump and the chamber (rapid regulating characteristic).

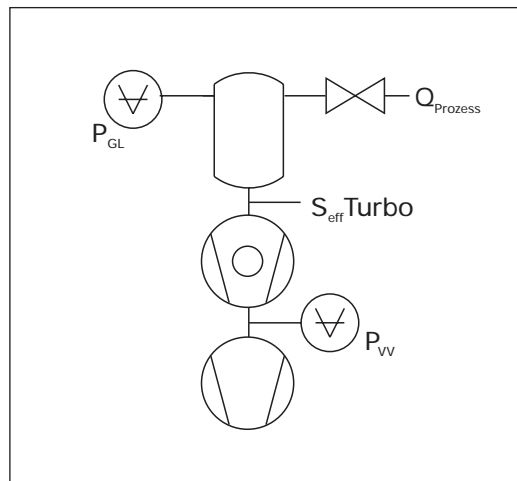

Figure 22:
Schematic
diagram of a
vacuum apparatus.

- Reduction of the rotation speed of the turbopump (slow regulating characteristic - no additional costs).

Formula 3 should also be used to select the size of the backing pump. The calculated fore-vacuum pressure P_{vv} with the gas load involved in the process should be at most 50 % of the maximum critical backing pressure of the turbopump. Of course, the desired evacuation time t_1 should also be taken into account (Formula 11).

The turbopump should be sufficiently cooled because gas friction brakes the rotor. The additional power necessary to maintain the rotation speed is taken from the electronic drive unit and leads to increased rotor and pump temperature. Heat radiation and conduction heat up the turbopump. Where low gas loads are involved, forced cooling by means of fans is usually adequate to avoid overheating and the turbopump being switched off.

4.3.2 High Gas Loads > 0.1 mbar · l/s

As already mentioned in Chapter 2, the pumping speed of turbopumps reduces at higher pressures. If the required equilibrium pressure is $>10^{-3}$ mbar, the pumping speed relevant for this pressure must be taken from that pumping speed curve of the turbopump and used to calculate according to Formula 2.

$$S_{TMP} = \frac{Q}{P_{HV}}$$

In addition, account must be taken as to whether the selected turbopump can pump the required gas load continuously without overloading. At high gas loads, turbopumps are subjected to great demands. Gas friction heats the rotors up to $120\text{ }^{\circ}\text{C}$ and there is the effect of varying rates of heat expansion on the different materials used.

The maximum permissible gas load is limited either by the drive power available or the maximum permissible operating temperature of the rotor (see also Chapter 3.4). Because the gas friction value is dependent on the molecular mass of the pumped gas, light gases such as hydrogen and helium scarcely generate any friction. In these cases, the limitation is often also dictated by the size of the backing pump. The backing pump must be selected so that the pressure $p_{vv}=Q/S_{vv}$ arising from the gas load is at most 50 % of the maximum forevacuum pressure of the turbopump.

It must be taken into account that where longer vacuum lines are involved on the exhaust of the turbopump, the required pressure can still be maintained. On turbo drag pumps, the power consumption and, therefore, the rotor temperature is largely independent of the fore-vacuum pressure. Because a large proportion of the power stored in the rotor is given up in the form of heat conduction to the pump casing, the specific thermal capacity of the gas plays a role in the setting of the temperature level for the rotor. Heavy noble gases lead to very high temperatures owing to their low thermal capacities and rate of heat conduction to the casing.

In any case, the heat stored in the turbopump has to be conducted away by water cooling. The maximum possible gas loads and the required cooling water amounts and temperatures can be found in the operating instructions for the respective turbopump.

To avoid rotor overheating resulting from gas loads that are too high, power characteristic curves are stored in the electronic drive units (see also page 16, chapter 3.4, fig. 18). There is the option of either gas type 0 for heavy noble gases (default setting) or gas type 1 for other gases. For the causes enumerated above, the permissible

power is lower in gas type 0. The following must, therefore, be taken into account when operating turbopumps: depending on the gas type and pump version, the rotation speed of the pump is reduced if the permissible gas load for the rated rotation speed is exceeded.

Corresponding to the power characteristic curve which permits higher power for lower rotation speeds, there arises an equilibrium with a specific rotation speed below the rated rotation speed. This alters (with fluctuations) the gas load. In order to ensure constant rotation speed and a corresponding stable process, the equilibrium rotation speed for the process should be ascertained and then, via rotation speed setting mode, a rotation speed selected which is somewhat below this equilibrium. The operation involving corrosive and condensable gases has been described in Chapter 2.4. Here it is only necessary to mention that in such cases specially coated pumps (C version) have to be used.

5. Intake And Outlet Line Losses

The connecting lines to the vacuum chamber cause a reduction in the pumping speed in vacuum pumps. Cross sections should, therefore, be as large as possible and the lines as short as possible. This chapter contains the calculation principles for losses in the intake and outlet lines. In some cases, the pumping speeds in the Formula in Chapter 4 have to be replaced by effective pumping speeds in order to ascertain the correct pumping times and equilibrium pressure.

The pressure on the high vacuum side is so low that as a rule molecular streaming is predominant. The condition here is an approximation:

$$p \cdot d < 10^{-2} \text{ Pa} \cdot \text{m}$$

Whereby p is the pressure and d the diameter of the connecting line. While molecular streaming collisions, of the molecules with each other is rare they are in practically free movement from wall to wall.

On the fore-vacuum side, this condition is usually not fulfilled; here, laminar streaming is predominant and the molecules collide with each other.

To calculate the effective pumping speed, knowledge of the conductance value of the connecting lines is necessary. Generally valid is:

$$\frac{1}{S_{\text{eff}}} = \frac{1}{S_{\text{rated}}} + \frac{1}{C_{\text{tot}}}$$

Formula 18.

Whereby S_{rated} is the rated pumping speed of the pump and C_{tot} the total conductance value of the connecting line.

5.1 Conductance Values for Molecular Flow

The conductance values of individual components are also determined by the given geometry. We will take a look in the next section at components usually used in a vacuum. The conductance value of an orifice with a cross-sectional area A is given by the mean particle speed \bar{c} of the gas (see Chapter 7, Composition of Atmospheric Air)

$$C_{\text{BL}} = \frac{A}{4} \bar{c} = \frac{d^2 \cdot \pi}{16} \bar{c}$$

Formula 19.

$$\bar{c} = \sqrt{\frac{8RT}{\pi M}}$$

Formula 20.

Here:

$$R = 8.3145 \frac{\text{kg} \cdot \text{m}^2}{\text{s}^2 \cdot \text{mol} \cdot \text{K}}$$

(general gas constant)

$$T = 293 \text{ K} \triangleq 20 \text{ }^\circ\text{C} \text{ (room temperature)}$$

$$M = 0.0288 \text{ kg/mol}$$

(mean molar mass for air)

$$\bar{c} = 464 \text{ m/s (mean thermal speed for air at } 293 \text{ K } \triangleq 20 \text{ }^\circ\text{C)}$$

For round pipes of length l ($l \gg d$) for air at 293 K

$$C_{\text{pipe}} = \frac{A \cdot d}{3 \cdot C} \quad \bar{c} = \frac{d^3 \cdot \pi}{12 \cdot C} \quad \bar{c}$$

Formula 21.

For short pipes ($l \leq d$) the conductance value is ascertained as follows:

$$\frac{1}{C} = \frac{1}{C_{BL}} + \frac{1}{C_{pipe}}$$

Formula 22.

The total conductance value of a connecting line comprising several part pieces is calculated as:

$$\frac{1}{C_{tot}} = \frac{1}{C_{BL}} + \frac{1}{C_{pipe1}} + \frac{1}{C_{pipe2}} + \dots$$

Formula 23.

C_{BL} is the orifice conductance value of the smallest aperture (Formula 19). It only then has to be taken into account if the connecting line contains a reduction in the cross section that is smaller than the intake opening on the turbopump. The conductance value of the intake opening is already taken into account in the stated pumping speed. C_{pipe1} , C_{pipe2} etc. are the conductance values of the individual pipe sections (Formula 21).

If the pump flange diameter is smaller or the same size as the diameter of the connecting line, only the proportion of the pipe length has to be taken into account.

Example:

A TMH 521 with flange DN160 ($S_{rated} = 500 \text{ l/s}$) is flanged to a vacuum chamber via a 0.2 m long pipe with an internal diameter of 0.1 m. What is the effective pumping speed on the chamber? (in accordance with Formula 18-23)

$$\frac{1}{C_{tot}} = \frac{1}{\frac{0,10^2 [\text{m}^2] \cdot \pi \cdot 464 [\text{m/s}]}{16}} + \frac{1}{\frac{0,10^3 [\text{m}^3] \cdot \pi \cdot 464 [\text{m/s}]}{12 \cdot 0,2}} = 2,74 \frac{\text{s}}{\text{m}^3}$$

$$C_{tot} = 0,364 \frac{\text{m}^3}{\text{s}} = 364 \frac{\text{l}}{\text{s}}$$

$$\frac{1}{S_{eff}} = \frac{1}{S_{rated}} + \frac{1}{C_{tot}} = \frac{1}{0,500} + \frac{1}{0,364} = 4,74 \frac{\text{s}}{\text{m}^3}$$

$$S_{eff} = 0,210 \frac{\text{m}^3}{\text{s}} = 210 \frac{\text{l}}{\text{s}}$$

The effective pumping speed on the chamber is now only 210 l/s. A directly flanged TMH 261 turbopump with 210 l/s rated pumping speed would also yield the same result. When using a connection with the same diameter as the pump flange (0.16 m), the effective pumping speed falls to just 430 l/s. When combined again, the total conductance value of a vacuum line is given by:

- The orifice conductance value at the smallest cross section in the line which is smaller than the cross section of the intake cross section of the turbopump.
- The conductance values of the individual line sections.

5. Intake And Outlet Line Losses

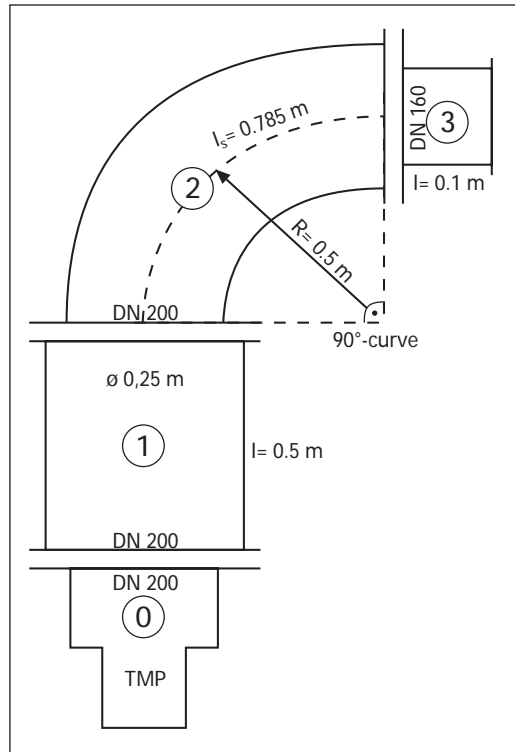

Example: Turbopumps with three additional pipe components of different geometry and the assumption that air must be pumped at 20 °C:

(1) Pipe diameter 0.25 m, length 0.5 m

$$C_{\text{pipe1}} = 121.5 \text{ [m/s]} \cdot 0.25^3 \text{ [m}^3\text{]} / 0.5 \text{ [m]} = 3.797 \text{ m}^3/\text{s}$$

(2) 90° bend, pipe diameter 0.2 m, stretched length $0.5 \cdot \pi/2$

The conductance value of a pipe elbow or a pipe bend of axis length l is with molecular streaming (within a few percentage points) the same as the conductance value of a straight pipe of length l

$$C_{\text{pipe2}} = 121.5 \text{ [m/s]} \cdot 0.2^3 \text{ [m}^3\text{]} (\pi \cdot 0.5 \text{ [m]}/2) = 1.238 \text{ m}^3/\text{s}$$

(3) Pipe diameter 0.16 m, length 0.1 m

$$C_{\text{pipe3}} = 121.5 \text{ [m/s]} \cdot 0.16^3 \text{ [m}^3\text{]}/0.1 \text{ [m]} = 4.977 \text{ m}^3/\text{s}$$

Diameter of the smallest cross section in the line 0.16 m

$$C_{\text{orifice}} = 91.1 \text{ [m/s]} \cdot 0.16^2 \text{ [m}^2\text{]} = 2.333 \text{ m}^3/\text{s}$$

The total conductance value of the line is

$$\begin{aligned} 1/C_{\text{tot}} &= 1/C_{\text{pipe1}} + 1/C_{\text{pipe2}} + 1/C_{\text{pipe3}} + 1/C_{\text{orifice}} \\ &= 1/3.797 \text{ [m}^3/\text{s]} + 1/1.238 \text{ [m}^3/\text{s]} + \\ &\quad 1/4.977 \text{ [m}^3/\text{s]} + 1/2.333 \text{ [m}^3/\text{s]} \\ &= 1.700 \text{ s/m}^3 \end{aligned}$$

$$C_{\text{tot}} = 0.588 \text{ m}^3/\text{s} = 588 \text{ l/s}$$

5.2 Conductance Values for Laminar Flow

Contrary to the position with molecular streaming where the conductance value is independent of the pressure, in the case of laminar streaming the conductance value increases with the pressure (long pipe, $l \gg d$):

$$C_{\text{pipe,lam}} = \frac{\pi}{128 \cdot \eta} \cdot \frac{d^4}{l} \cdot \frac{p_1 + p_2}{2}$$

Formula 24.

η is the viscosity of the gas ($\eta_{\text{air}} = 18.2 \cdot 10^{-6} \text{ kg/m} \cdot \text{s}$), d and l are the diameter and the length of the pipe, p_1 and p_2 the pressures on both sides of the vacuum line.

Blocking

From a certain surface conductance value there is no further increase: the streaming has attained sonic speed and cannot increase further. This is known as blocking and arises with air at 20 °C from a conductance value of

$$C_{\text{max}} = A \cdot 200 \frac{\text{m}}{\text{s}}$$

Formula 25.

A is the penetration surface of the streaming.

For calculation purposes, the respective smaller conductance value in Formula 24 and 25. The effective pumping speed can then be found using Formula 18.

Example:

What effective pumping speed does a backing pump with rated pumping speed of 16 m³/h have, which is connected to the vacuum chamber via a fore-vacuum line of length 1m and diameter 2.5 cm at pressures of 1000, 100, 1 and 0.1 mbar?

1. Blocking conductance value in accordance with Formula 25:

$$\begin{aligned} C_{\max} &= 0.025^2 [\text{m}^2] \cdot \pi/4 \cdot 200 [\text{m/s}] \\ &= 0.098 \text{ m}^3/\text{s} \\ &= 98 \text{ l/s} \end{aligned}$$

2. Pipe conductance value in accordance with Formula 24:

$$\begin{aligned} C_{\text{pipe}, 1000} &= \\ &= 53 \text{ m}^3/\text{s} \\ &= 53000 \text{ l/s} \end{aligned}$$

3. Pipe conductance value at 100 mbar, 1 mbar, 0.1 mbar

On account of the proportion to p:

$$\begin{aligned} C_{\text{pipe}, 100} &= 5300 \text{ l/s} \\ C_{\text{pipe}, 1} &= 53 \text{ l/s} \\ C_{\text{pipe}, 0,1} &= 5.3 \text{ l/s} \end{aligned}$$

4. On account of $C_{\max} < C_{\text{pipe}, 1000}$ and $C_{\max} < C_{\text{pipe}, 100}$ is, according to formula 18:

$$\begin{aligned} S_{\text{eff}, 1000} &= S_{\text{eff}, 100} \\ &= 1/(1/98 [\text{l/s}] + 1/4.4 [\text{l/s}]) \\ &= 4.21 \text{ l/s} \end{aligned}$$

In the higher pressure range the pumping speed nearly corresponds to the rated pumping speed.

$$S_{\text{eff}, 1} = \frac{1}{\frac{1 \cdot [\text{s}]}{53 \cdot [\text{l}]} + \frac{1 \cdot [\text{s}]}{4,4 \cdot [\text{l}]}} = 4,1 \text{ l/s}$$

$$S_{\text{eff}, 0,1} = \frac{1}{\frac{1 \cdot [\text{s}]}{5,3 \cdot [\text{l}]} + \frac{1 \cdot [\text{s}]}{4,4 \cdot [\text{l}]}} = 2,4 \text{ l/s}$$

In the lower pressure range, the effective pumping speed through the line is markedly reduced. This is especially important for the calculation of the equilibrium pressure for gas load operations. Another important, but difficult to calculate, reduction of the pumping speed arises for the rough evacuation of a vacuum vessel if evacuation is to be performed via the turbopump. The turbopump represents a resistance before it reaches its operating speed. This internal conductance value can prolong the pumping time. Depending on the pump size, the conductance value of the pump can be between approximately 10 and 100 l/s (blocking) and has a considerable effect on the effective pumping speed at higher pressures and pumping times when very large backing pumps are used.

6. Application Examples

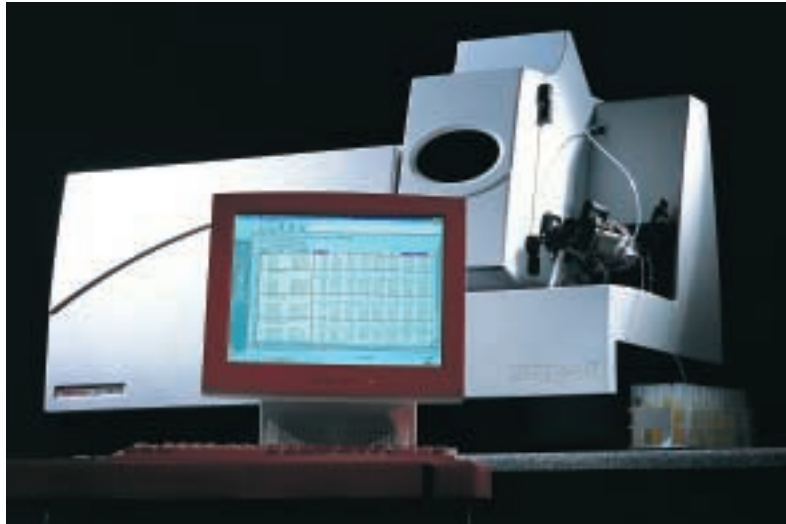

Inductively Coupled Plasma Mass Spectrometer.
For analytical challenges such as chemical analysis, drinking water purity,
wine analysis and biological sampling of coral. SplitFlow™ Turbo 261-250.
Thermo Elemental, UK



Ion Implantation System.
Doping of semiconductors.
The atoms to be implanted are ionized, accelerated and shot into the target
semiconductor. Two CompactTurbo 521. Varian Semiconductor Inc., USA



Semi automated Wafer Bonding System.
 Fully automated cassette-to-cassette align and bond operations for MicroElectroMechanicalSystems and Silicon-On-Isolator production. Advanced spray coating technology. Turbo Drag Pump TMH 071 P and Diaphragm pump.
 EVGroup, Austria



Vacuum Chamber to produce LCD-Displays.
 Vacuum chamber for filling cholestic liquid crystal materials. Compact Turbo TMH 261, Rotary Vane Pumps Duo 5, Duo 20 and Duo 35, Compact Process Ion Gauge IMR 265 and Valve EVR 116.
 LC-Tech, Sweden

6. Application Examples



Glass coating system. Coating architectural glass with 15 CompactTurbo 2201.
Von Ardenne Anlagentechnik, Dresden, Germany



Glass coating system with 22 TPH 2101 UP.
The electrical cabinet (protection class IP 54)
contains all electrical components to operate the
pumps. All functions of the pumps are controlled
via profibus. Saint Gobain Glass, France

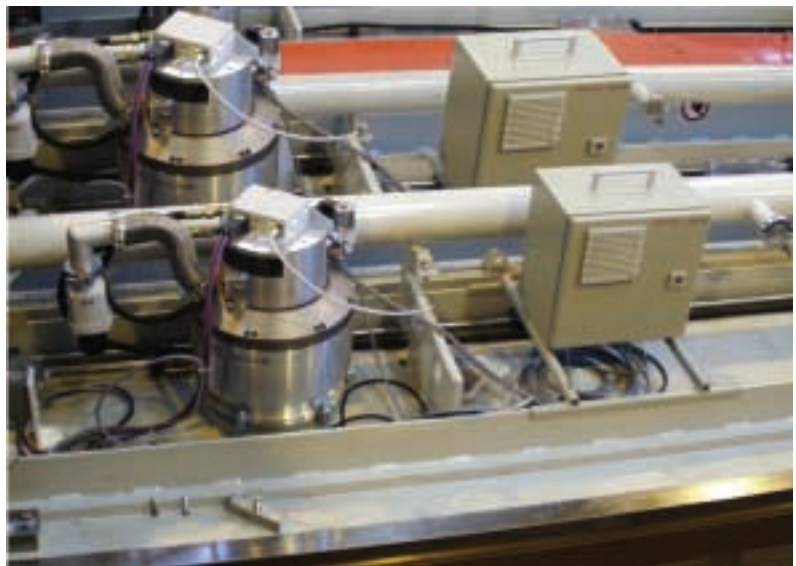

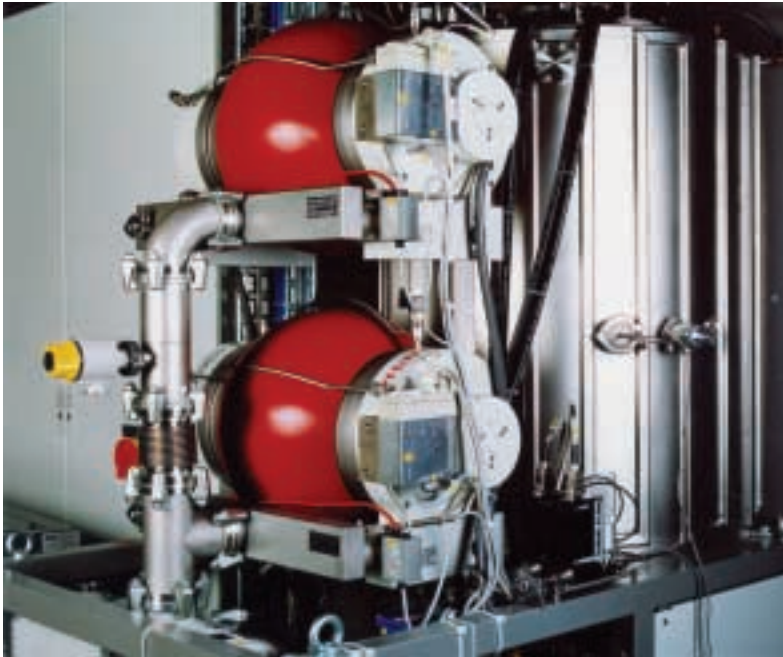

Classic 580 dual pumping station with two TMH 2201 turbopumps, without a bypass. Pfeiffer Vacuum



Ophthalmic Coaters. Deposition of anti-reflection films on lenses. CompactTurbo TPH 2101, Rotary Vane Pump DUO 65 and Valves EVB 100, EVB 040. Satis, Italy

7. Data Lists

SI Basis Units

| Description | Basis Unit | Unit Sign |
|---------------------------|------------|-----------|
| Length | Meter | m |
| Mass | Kilogram | kg |
| Time | Second | s |
| Electrical current power | Ampere | A |
| Thermodynamic temperature | Kelvin | K |
| Material volume | Mol | mol |
| Luminosity | Candela | cd |

Derived SI Units with Special Names

| Description | Definition | Formula | Unit | Unit Sign |
|-------------|---------------------|-----------------------------------|--------|-----------|
| Force | Mass x acceleration | $1 \text{ kg} \cdot \text{m/s}^2$ | Newton | N |
| Pressure | Force/surface | 1 N/m^2 | Pascal | Pa |
| Work | Force x path | $1 \text{ N} \cdot \text{m}$ | Joule | J |
| Power | Work/time | 1 J/s | Watt | W |

Desorption Rates

| Material | Surface-Characteristic | Surface Condition | Desorption Rate ¹⁾ q_{des} | | |
|-----------------|------------------------|--|--|----------------------|----------------------|
| | | | 1 h | 4 h | 10 h |
| Stainless steel | Blank | Cleaned | $2.7 \cdot 10^{-7}$ | $5.4 \cdot 10^{-8}$ | $2.7 \cdot 10^{-8}$ |
| Stainless steel | Polished | Cleaned | $2 \cdot 10^{-8}$ | $4 \cdot 10^{-9}$ | $2 \cdot 10^{-10}$ |
| Stainless steel | Caustic | Baked out 1 h with normal air, ventilated | $1.4 \cdot 10^{-9}$ | $2.8 \cdot 10^{-10}$ | $1.4 \cdot 10^{-10}$ |
| Stainless steel | Blast beaded | Baked out 1 h with normal air, ventilated | $3 \cdot 10^{-10}$ | $6.5 \cdot 10^{-11}$ | $4 \cdot 10^{-11}$ |
| Ni plated steel | Polished | Cleaned | $2 \cdot 10^{-7}$ | $1.5 \cdot 10^{-8}$ | $5 \cdot 10^{-9}$ |
| Cr plated steel | Polished | Cleaned | $1.3 \cdot 10^{-8}$ | $2.2 \cdot 10^{-9}$ | $1.2 \cdot 10^{-9}$ |
| Steel | | Rusted | $6 \cdot 10^{-7}$ | $1.6 \cdot 10^{-7}$ | $1 \cdot 10^{-7}$ |
| Steel | Blank | Cleaned | $5 \cdot 10^{-7}$ | $1 \cdot 10^{-7}$ | $5 \cdot 10^{-8}$ |
| Steel | Blast beaded | Cleaned | $4 \cdot 10^{-7}$ | $8 \cdot 10^{-8}$ | $3.8 \cdot 10^{-8}$ |
| Aluminium | | Cleaned | $6 \cdot 10^{-8}$ | $1.7 \cdot 10^{-8}$ | $1.1 \cdot 10^{-8}$ |
| Brass | | Cleaned | $1.6 \cdot 10^{-6}$ | $5.6 \cdot 10^{-7}$ | $4 \cdot 10^{-7}$ |
| Copper | | Cleaned | $3.5 \cdot 10^{-7}$ | $9.5 \cdot 10^{-8}$ | $5.5 \cdot 10^{-8}$ |
| Porcelain | Glazed | | $8.7 \cdot 10^{-7}$ | $4 \cdot 10^{-7}$ | $2.8 \cdot 10^{-7}$ |
| Glass | | Cleaned | $4.5 \cdot 10^{-9}$ | $1.1 \cdot 10^{-9}$ | $5.5 \cdot 10^{-10}$ |
| Acrylic glass | | | $1.6 \cdot 10^{-6}$ | $5.6 \cdot 10^{-7}$ | $4 \cdot 10^{-7}$ |
| Neoprene | | | $4 \cdot 10^{-5}$ | $2.2 \cdot 10^{-5}$ | $1.5 \cdot 10^{-5}$ |
| Perbunane | | | $4 \cdot 10^{-6}$ | $1.7 \cdot 10^{-6}$ | $1.3 \cdot 10^{-6}$ |
| Viton | | | $1.2 \cdot 10^{-6}$ | $3.6 \cdot 10^{-7}$ | $2.2 \cdot 10^{-7}$ |
| Viton | | Baked out for 4 hours at 100 °C | $1.2 \cdot 10^{-7}$ | $5 \cdot 10^{-8}$ | $2.8 \cdot 10^{-8}$ |
| Viton | | Baked out for 4 hours at 150 °C | $1.2 \cdot 10^{-9}$ | $3.3 \cdot 10^{-10}$ | $2.5 \cdot 10^{-10}$ |
| Teflon | | Degassified | $8 \cdot 10^{-7}$ | $2.3 \cdot 10^{-7}$ | $1.5 \cdot 10^{-7}$ |

1) Diverse pre-treatment can lead to improvements in the desorption rates (for example hydrogen free annealing)

Permeation Constants

| Material | Permeation Constants $q_{\text{Perm}} \left[\frac{\text{m}^3}{\text{s}} \right]$ at 20 °C | | | | | |
|-----------------------|--|----------------------|----------------------|----------------------|----------------------|----------------------|
| | CO ₂ | H ₂ | He | O ₂ | N ₂ | Ar |
| Viton A | $6 \cdot 10^{-12}$ | $3.5 \cdot 10^{-12}$ | $7.5 \cdot 10^{-12}$ | – | – | – |
| Perbunane | – | $7.5 \cdot 10^{-12}$ | $7.5 \cdot 10^{-12}$ | $6 \cdot 10^{-13}$ | – | $1.3 \cdot 10^{-12}$ |
| Neoprene | $2 \cdot 10^{-11}$ | $7.5 \cdot 10^{-12}$ | $7.2 \cdot 10^{-12}$ | $1.4 \cdot 10^{-12}$ | $1.9 \cdot 10^{-13}$ | $1.2 \cdot 10^{-12}$ |
| PTFE | $1.2 \cdot 10^{-13}$ | $1.8 \cdot 10^{-11}$ | $5.3 \cdot 10^{-10}$ | $7.5 \cdot 10^{-12}$ | $2 \cdot 10^{-12}$ | $4.4 \cdot 10^{-12}$ |
| Rubber | $7 \cdot 10^{-11}$ | $3.4 \cdot 10^{-11}$ | $2.2 \cdot 10^{-11}$ | $2 \cdot 10^{-11}$ | $5.3 \cdot 10^{-12}$ | $1.5 \cdot 10^{-12}$ |
| Vespel (polyamide) | $2 \cdot 10^{-13}$ | – | $1.9 \cdot 10^{-12}$ | $1 \cdot 10^{-13}$ | $3 \cdot 10^{-14}$ | – |
| Silicon | $25 \cdot 10^{-10}$ | $9.5 \cdot 10^{-10}$ | $2.9 \cdot 10^{-10}$ | $5 \cdot 10^{-10}$ | $2.7 \cdot 10^{-10}$ | $5.3 \cdot 10^{-10}$ |

Composition of Atmospheric Air and Mean Thermal Speed

| Gas Type | Partial Pressure in mbar | Middle Speed \bar{c} in m/s | Middle Molecule mass kg/mol (20° C) |
|-----------------------------------|--------------------------|-------------------------------|-------------------------------------|
| Nitrogen (N ₂) | 791 | 471 | 28 |
| Oxygen (O ₂) | 212 | 440 | 29 |
| Argon (Ar) | 9.46 | 394 | 40 |
| Water vapor (H ₂ O) | ≤ 23 | 587 | 18 |
| Carbon dioxide (CO ₂) | 0.32 | 375 | 44 |
| Neon (Ne) | $1.8 \cdot 10^{-2}$ | 557 | 20 |
| Helium (He) | $5.3 \cdot 10^{-3}$ | 1245 | 4 |
| Krypton (Kr) | $1.1 \cdot 10^{-3}$ | 272 | 84 |
| Hydrogen (H ₂) | $5.1 \cdot 10^{-4}$ | 1761 | 2 |
| Xenon (Xe) | $8.7 \cdot 10^{-5}$ | 217 | 131 |
| Ozone (O ₃) | $2.0 \cdot 10^{-5}$ | 360 | 48 |

Influence of magnetic fields on turbo pumps

| Type | 011 | 071 | 261 | 521 | 1001 | 1601 | 2101 |
|------------------|-----|-----|-----|-----|------|------|------|
| B _{Max} | 3 | 4 | 5,5 | 5 | 3 | 3 | 7 |
| ΔP | - | 3 | 8 | 14 | 20 | 35 | 80 |

7. Data Lists

Frequency Analysis for Turbomolecular Pumps

Frequency analysis TMH 200 M

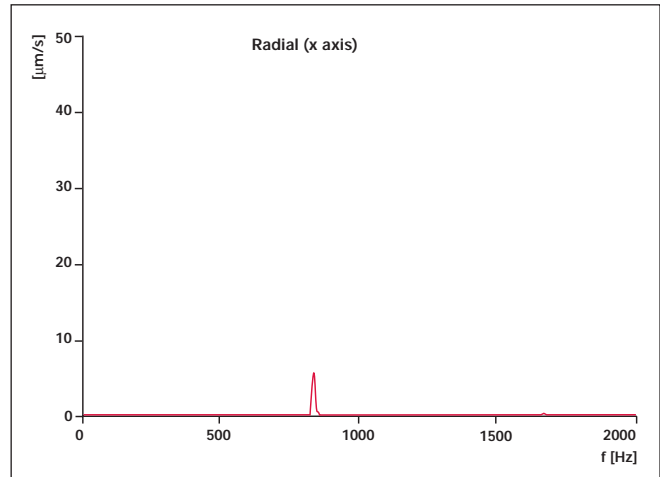
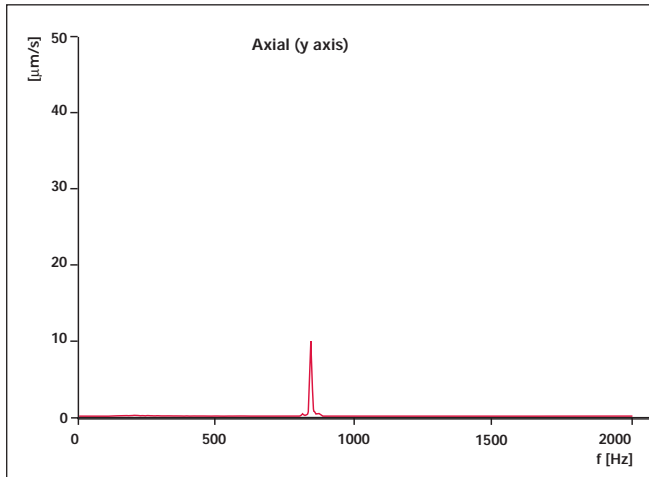

Frequency analysis TMH 400 M

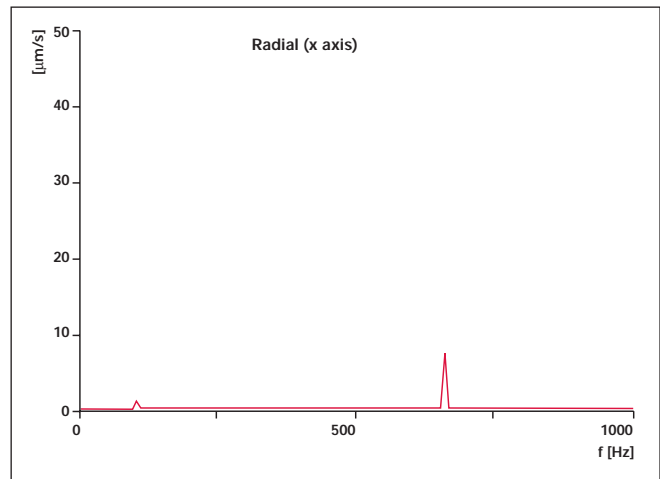
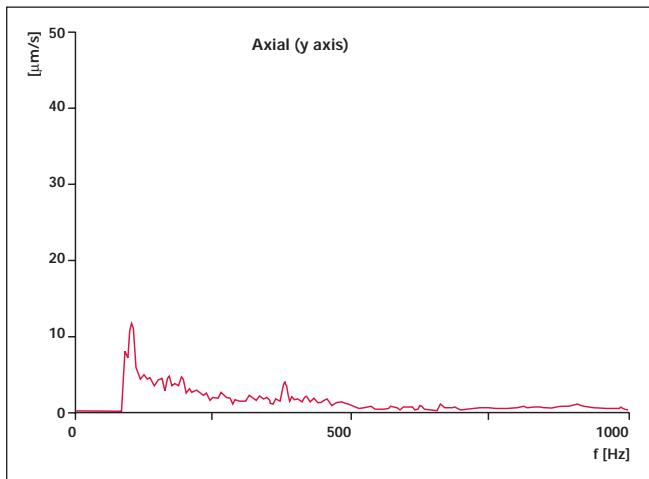

Frequency analysis TMH 1000 M

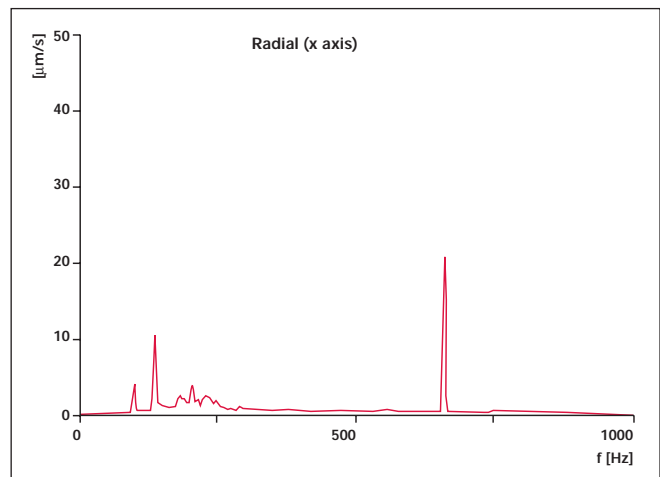
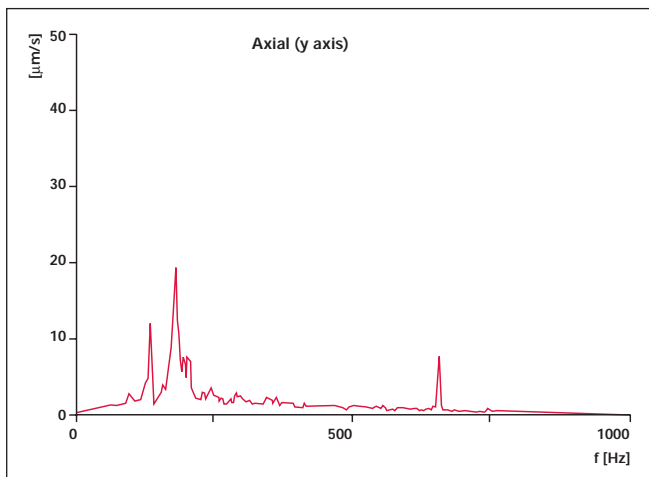

Frequency analysis TMH 1600 M

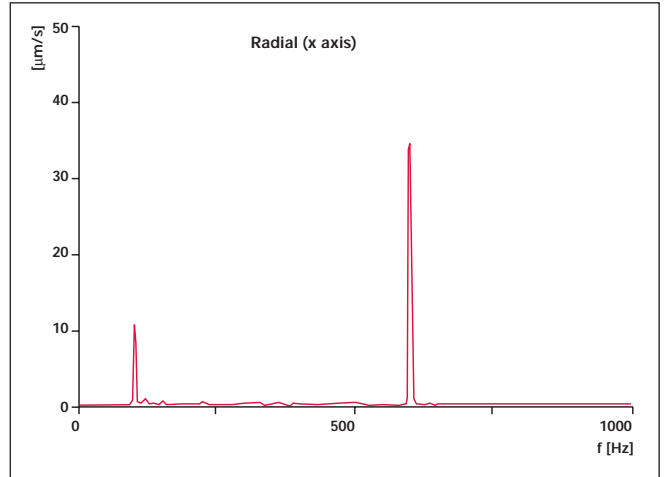
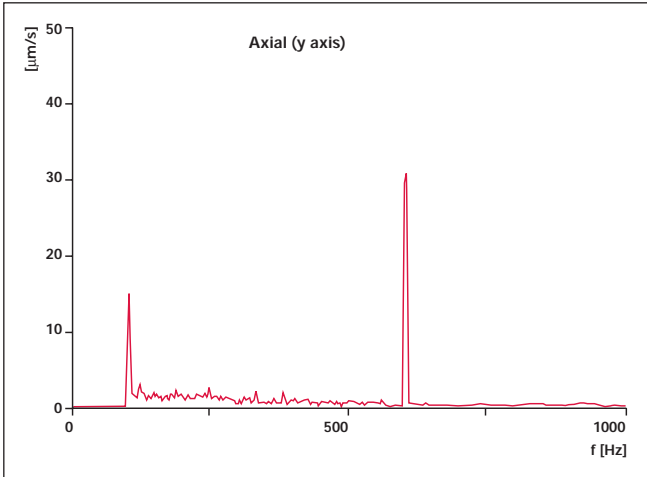

Frequency analysis HiMag™ 2400

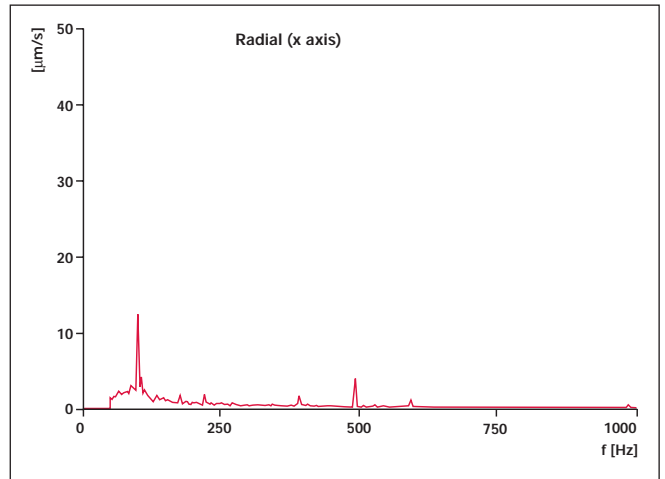
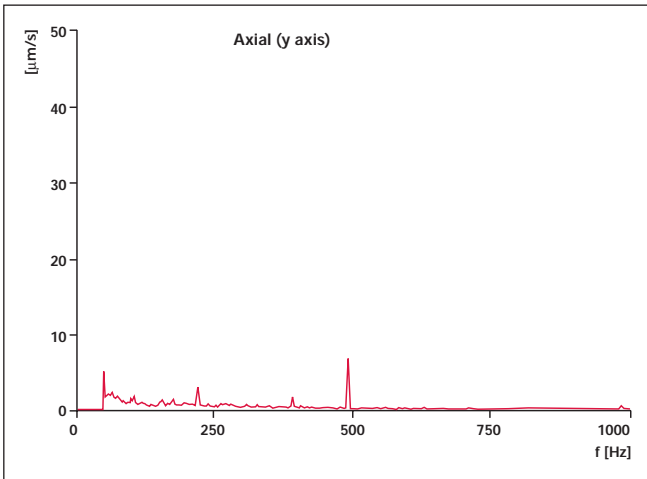

Frequency analysis TMH 071

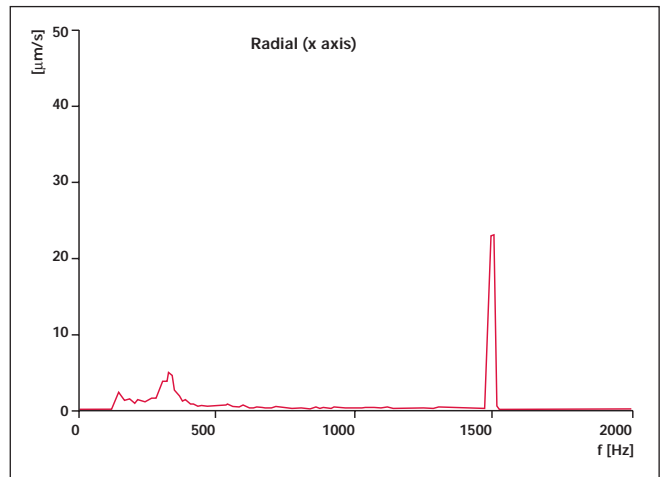
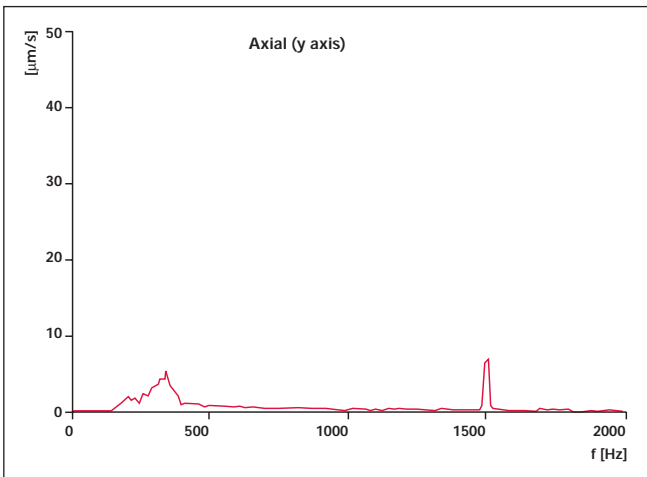

7. Data Lists

Frequency analysis TMH 261

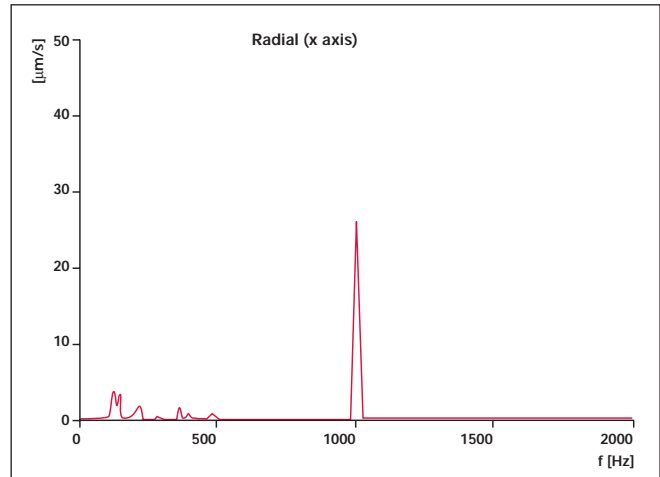
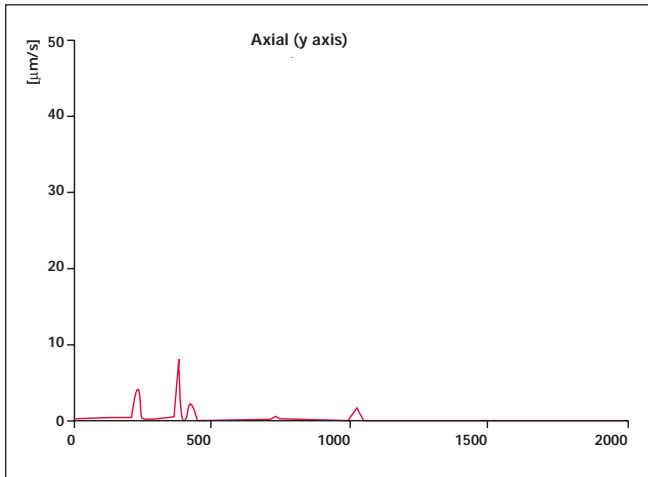

Frequency analysis TMH 521

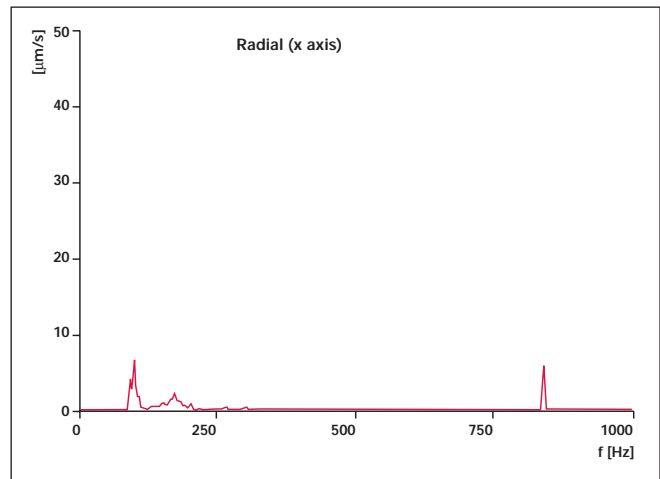
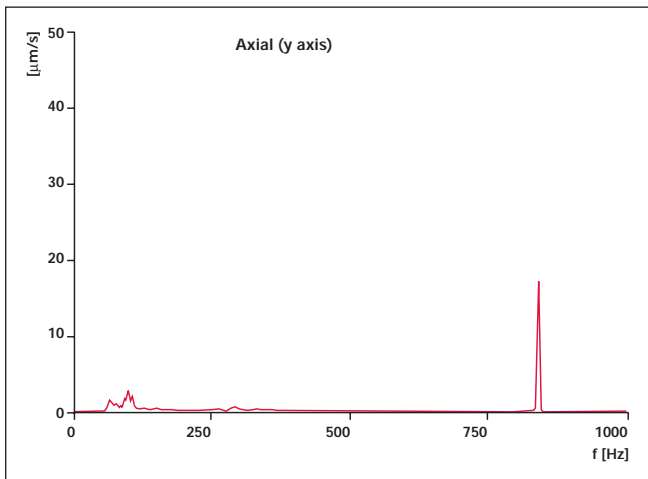

Frequency analysis TMH 1001

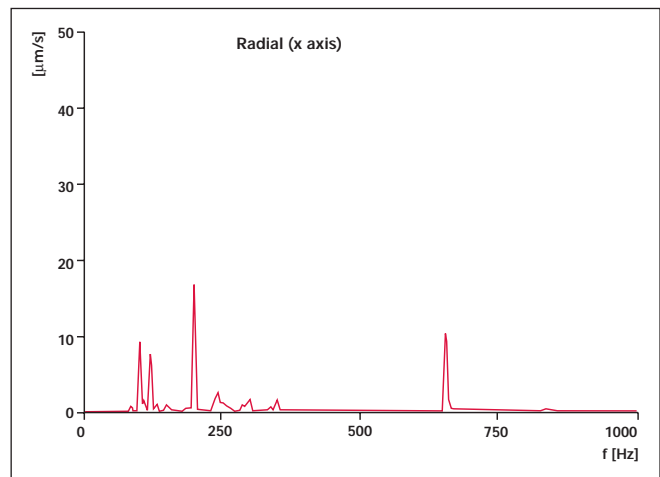
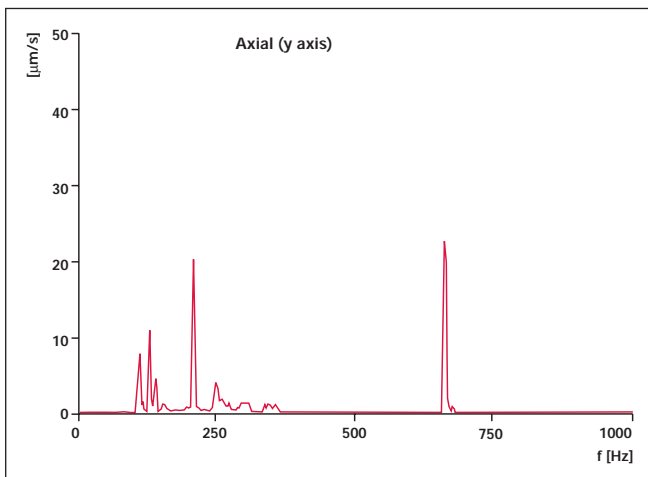

Frequency analysis TMH 1601

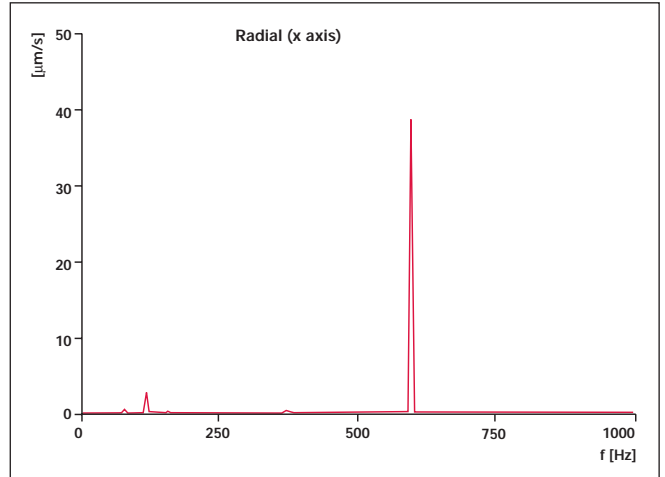
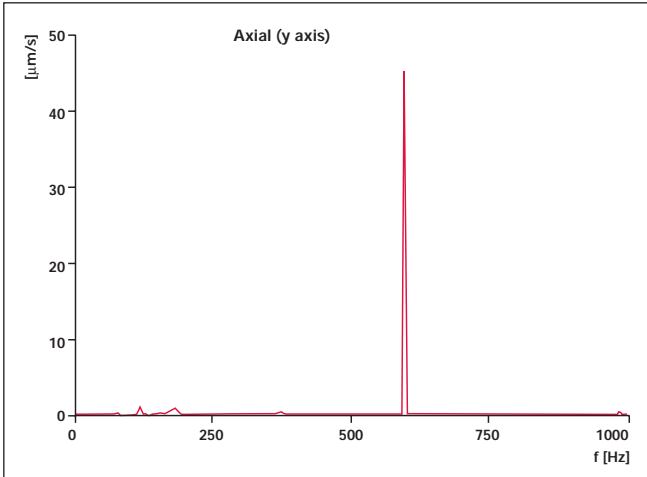



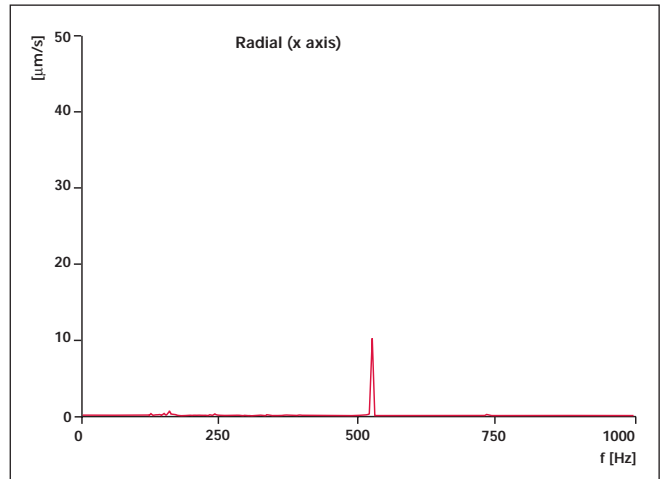
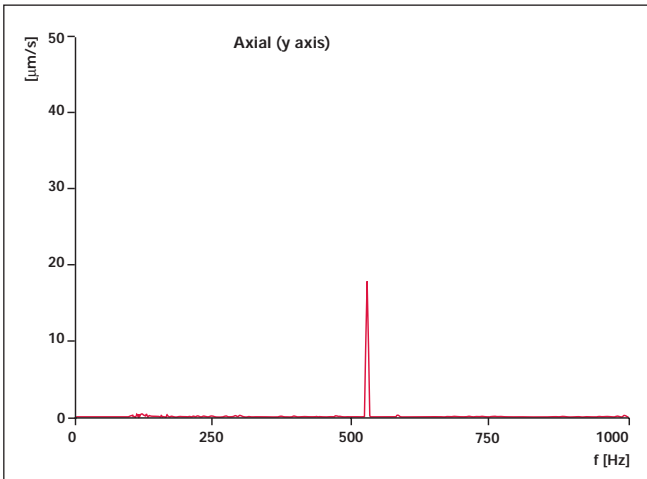













Frequency analysis TPH 2101/2301











Symbols in Vacuum technology



Vacuum pumps

-  Vacuum pumps in general
-  Reciprocating piston pump
-  Diaphragm vacuum pump
-  Positive displacement pump, rotating*)
-  Rotary piston pump*)
-  Rotary vane vacuum pump*)
-  Rotary piston vacuum pump*)
-  Roots vacuum pump*)
-  Turbo vacuum pump in general
-  Turbomolecular pump
-  Fluid entrainment pump*)
-  Diffusion pump*)
-  Adsorption pump*)
-  Getter pump
-  Sputtering ion pump
-  Cryopump
-  Scroll pump*)









Vacuum accessories

-  Separators in general
-  Separators with heat exchanger, for example cooled
-  Gas filters in general
-  Filters, filter apparatus in general
-  Vapor locks in general
-  Vapor locks, cooled
-  Cooling traps in general
-  Cooling traps with supply vessels
-  Sorption traps





Vessels

-  Vessels with convex base, general vacuum vessels
-  Vacuum bells













Shut-off units





-  Shut-off units in general
-  Shut-off valves, through valves
-  Angle valves
-  Through cocks
-  Three way cocks
-  Angle cocks
-  Shut-off vanes
-  Shut-off flaps
- Shut-off units with safety function

Shut-off unit drives







-  Manual drives
-  Dosing valves
-  Electromagnetic drives
-  Fluid drives (hydraulic or pneumatic)
-  Electromotor drives

Connections and lines

-  Flange connections in general
-  Screwed flange connections
-  Small flange connections
-  Clamping flange connections
-  Tubular screwed connections
-  Ball and socket joint connections
-  Muffle connections
-  Taper ground joint connections
-  Crossing of two lines with connection point
-  Crossing of two lines without connection point
-  Branch
-  Mobile line (for example compensator, connecting hose)

-  Slide feedthrough with flange
-  Slide feedthrough without flange
-  Rotary vane feed-through
-  Electric cable feed-through

Measurement and vacuum gauges

-  Vacuum (for the identification of vacuum)
-  Vacuum measurement, vacuum gauge head
-  Vacuum gauge, operating and display unit for gauge heads
-  Vacuum gauge, registering (in writing)
-  Vacuum gauge with analog display
-  Vacuum gauge with digital display
-  Flow measurement

All figures, with the exception of asterisked units) are independent of installation position*

The vacuum technology experts



For over 110 years, we have set the standard in vacuum engineering, generation, measurement, and analysis with our comprehensive line of single components to complex vacuum systems.

Quality and service world-wide from the inventors of the turbo pump. We are the world leader with more than 250,000 turbo pumps shipped to date.

Sales and service world-wide

- ▶ Global on-site service
- ▶ Fast action logistics concept
- ▶ Customized service contracts
- ▶ 24-hour hotline
- ▶ Complete on site-training program at customer's facility

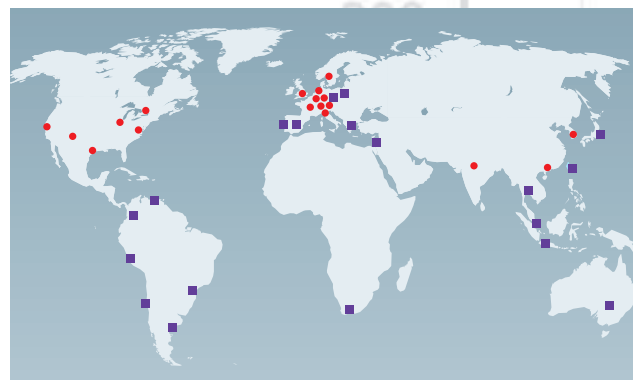

● Sales companies ■ Agencies

PFEIFFER  **VACUUM**

Pfeiffer Vacuum · Headquarters/Germany

Phone +49-(0) 64 41-8 02-0 · Fax +49-(0) 64 41-8 02-2 02 · info@pfeiffer-vacuum.de · www.pfeiffer-vacuum.net