

FISCHER CORE SERIES

BRASS

CHAPTERS

- B1** INTRODUCTION
- B2** MULTIPOLE **LOW & HIGH VOLTAGE**
- B3** COAX **LOW & HIGH VOLTAGE**
- B4** TRIAX
- B5** MIXED **COAX & HIGH VOLTAGE**
- B6** **ACCESSORIES & TOOLING**



B1

CHAPTER



FISCHER CORE SERIES **BRASS** INTRODUCTION

- Body styles B 1-2
- Locking system B 1-4
- Size selection B 1-6
- Part numbering B 1-8
- Contact configurations B 1-10
- Technical dimensions (Panel cut-outs) B 1-12
- Technical information B 1-13
- Options B 1-16

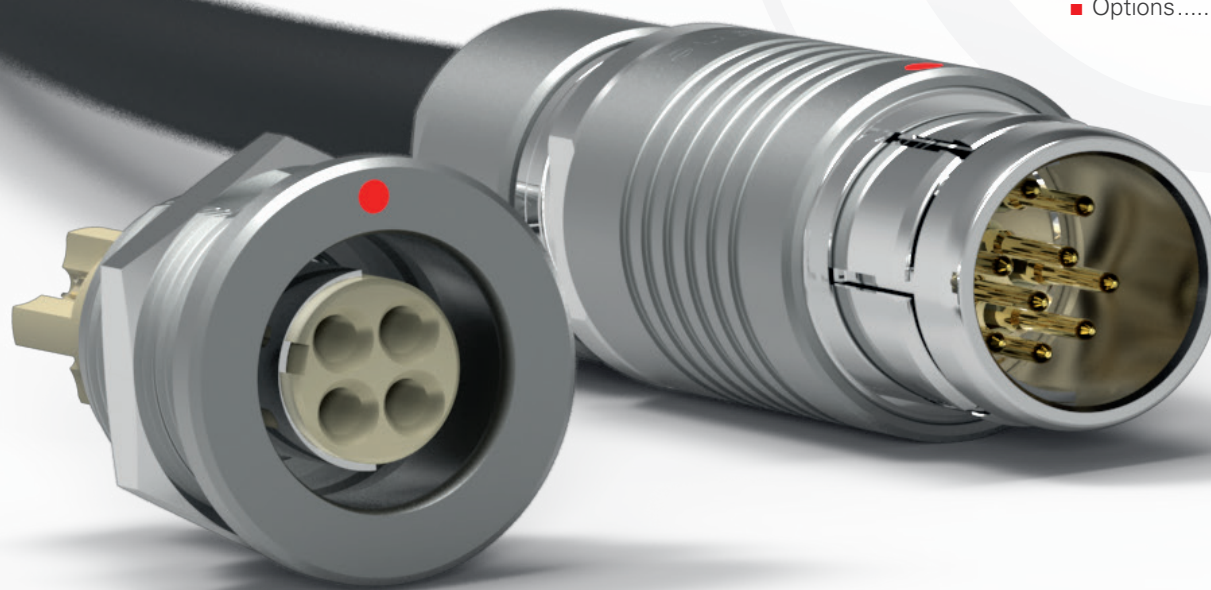

PLUGS

CABLE MOUNTED

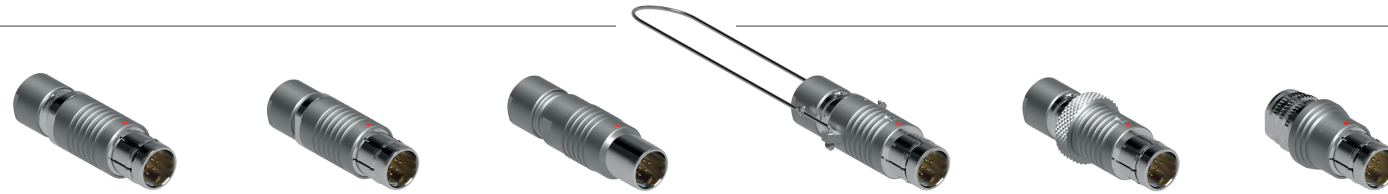

BODY STYLES	S	SC	SOV	SA	SV	SS
Locking system	Push-pull	Quick-release	Non-locking	Push-pull	Push-pull	Push-pull
Sealing	IP50 / IP68	IP50 / IP68	IP50 / IP68	IP50 / IP68	IP50 / IP68	IP50 / IP68
Design	Standard	Standard	Standard	Lanyard	Tamperproof	Short/Overmolding



BODY STYLES	SSC	WSO
Locking system	Quick-release	Push-pull
Sealing	IP50 / IP68	IP50 / IP68
Design	Short/Overmolding	Right-angle

PANEL FRONT MOUNTED



BODY STYLES	SF	SFU	SFE
Locking system	Non-locking	Non-locking	
Sealing	IP50	IP68	Hermetic
Design	Front-projecting	Front-projecting	

PANEL REAR MOUNTED



BODY STYLES	SFPU	SFPE
Locking system	Non-locking	
Sealing	IP68	Hermetic
Design	Front-projecting	

RECEPTACLES

CABLE MOUNTED



BODY STYLES	K	KE	KS	KSE
Sealing	IP50	IP68	IP50	IP68
Design	Standard		Short/Overmolding	

RECEPTACLES & FEEDTHROUGH

SPECIAL DESIGN



BODY STYLES	DG	DGP	WDE
Sealing	IP50	IP50	Hermetic
Design	Completely threaded Solder/Crimp		Bulkhead feedthrough
		PCB	

PANEL FRONT MOUNTED



BODY STYLES	D	DB	DEU	DEE	DBEU	DBEE	DK	DKE
Sealing	IP50	IP50	IP68	Hermetic	IP68	Hermetic	IP50	IP68
Design	Rear-projecting	Front-projecting	Rear-projecting		Front-projecting		Cable mounted	Cable mounted

PANEL REAR MOUNTED



BODY STYLES	DBP	DBPC	DBPU	DBPE	DBPLU	DBPLE	DKBE
Sealing	IP50	IP50	IP68	Hermetic	IP68	Hermetic	IP68
Design	Rear-projecting	Right-angle PCB	Rear-projecting		Front-projecting		Cable mounted

PUSH-PULL AUTOMATIC LOCKING PLUGS

S - SS - WSO

Fischer Connectors' original push-pull automatic locking is widely adopted by the industry for its ease of use, safety of mating and speed in connection and disconnection.

- Fully secured against accidental disconnection, it provides unparalleled signal integrity.
- Integrated into the connector housing, it is ideal for compact product design.
- For more details on Fischer Connectors' locking systems, visit: www.fischerconnectors.com

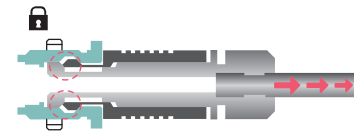

Secure locking when cable pulled

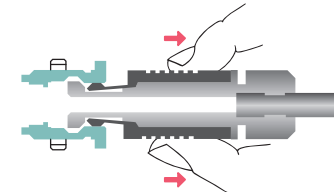

Pull the outer sleeve to unlock

QUICK-RELEASE PLUGS

SC - SSC

Fischer Connectors' quick-release plugs are designed without locking mechanism for emergency release.

- Quick-release plugs snap into the receptacle with an audible "click".
- A strong pull on the cable will allow unmating of the plug.
- Specially suited to avoid injuries to the users and damages to the material in case of accidental stress.

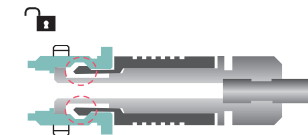

Clicking mechanism

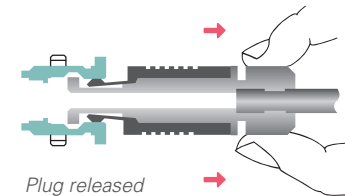

Plug released when cable pulled

Locking system

FISCHER CORE SERIES **BRASS**

LANYARD PLUG

SA

The lanyard plug combines push-pull automatic locking with an release lanyard.

- A strong pull on the lanyard will unlock the latching mechanism.
- Specially suited to allow quick unmating on the field.

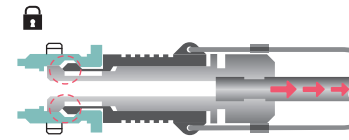

Secure locking when cable pulled

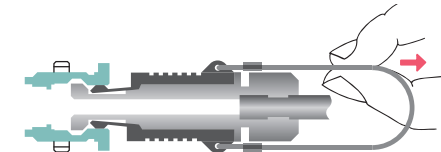

Pull the lanyard to unlock

FRICTION PLUGS

SOV - SF - SFE/SFU - SFPE/SFPU

Our non-locking plugs are designed without clicking mechanism.

- A soft pull on the connector will release the plug.
- Specially suitable for connections with limited accessibility and/or requiring no locking.



No clicking

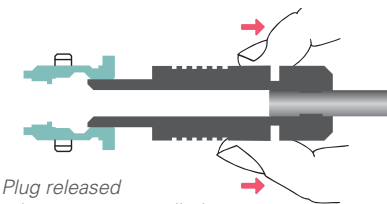

Plug released when connector pulled

TAMPERPROOF PLUG

SV

Our tamperproof plug features an integral safety locking ring to prevent unauthorized or unintentional release.

- When tightened, the knurled ring will prevent unmating of the plug.
- Specially suitable for applications involving high voltage or current.

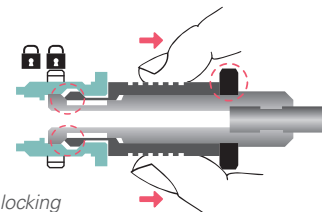

Secure locking when knurled ring tightened

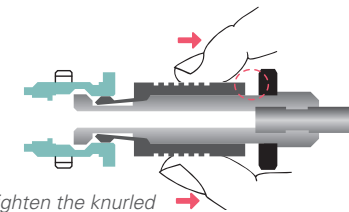

Untighten the knurled ring and pull the outer sleeve to unlock

All dimensions and images shown are in millimeters and are for reference only.

CONNECTOR SIZE VERSUS CABLE DIAMETER

¹⁾ Pictures represent standard S plug, but values can be extended to all cable mounted plugs, except for SS/SSC body styles.
²⁾ For max cable ø, values in parenthesis are valid for sealed connectors (IP68).



Series	Multipole low voltage		
	Min Cable ø	Max Cable ø	Nbr of Contacts
102	1.5	4.7 (4.3) ²⁾	2-9
103	1.7	6.7 (6.2) ²⁾	2-12
1031	2.2	7.2 (6.7) ²⁾	10-19
104	2.9	8.7	2-27
105	1.5	10.7	2-27
106	4.2	19.2	3-24
107	5.7	22.7	4-55

For more information see *Multipole low voltage* section, page B 2-39

Size selection

FISCHER CORE SERIES **BRASS**

LV = Low Voltage HV = High Voltage

Multipole high voltage			Coax low voltage		Coax high voltage		Triax		Mixed high voltage			Mixed coax		
Min cable ø	Max cable ø	Nbr of contacts	Min cable ø	Max cable ø	Min cable ø	Max cable ø	Min cable ø	Max cable ø	Min cable ø	Max cable ø	Nbr of contacts	Min cable ø	Max cable ø	Nbr of contacts
			1.5	4.7 (4.3)	1.5	4.7 (4.3)	1.5	4.7 (4.3)						
			1.7	6.7 (6.2)	1.7	6.7 (6.2)	1.7	6.7 (6.2)						
2.9	8.7	4 HV	2.9	8.7	2.9	8.7			2.9	8.7	1 LV 2 HV	2.9	8.7	1 Coax 1-4 LV
3.2	10.7	3-5 HV	3.2	10.7	3.2	10.7			3.2	10.7	1-10 LV 1-4 HV	3.2	10.7	1 Coax 1-9 LV
4.2	19.2	6-7 HV							4.2	19.2	6 LV 2 HV			
5.7	22.7	7 HV			5.7	22.7								
For more information see <i>Multipole high voltage</i> section, page B 2-58			For more information see <i>Coax low voltage</i> section, page B 3-23		For more information see <i>Coax high voltage</i> section, page B 3-34		For more information see <i>Triax</i> section, page B 4-18		For more information see <i>Mixed high voltage</i> section, page B 5-24			For more information see <i>Mixed coax</i> section, page B 5-16		

All dimensions and images shown are in millimeters and are for reference only.

ORDERING INFORMATION

How to build a part number

Fischer Connectors Core Series Brass is built on a modular design and offers over 20,000 standard configurations.

Refer to the table aside to find the information you need to build the part number to order your selected connector.

For customized solutions, please contact us.

CONNECTORS PARTS

Part system	Body style	Size	Polarity
-------------	------------	------	----------

PART NUMBER EXAMPLES

Plug	S	102	A
------	---	-----	---

S cable mounted plug in Series 102 with 7 (multipole) low voltage male contacts and following options.

Receptacle	D	102	A
------------	---	-----	---



D panel mounted receptacle in Series 102 with 7 (multipole) low voltage female contacts and following options.

Cable mounted plugs S/SC SOV SA SV SS/SSC WSO	Series 102 103 1031 104 105 106 107	As standard rule A = male contacts on plug and female contacts on receptacle Z = female contacts on plug and male contacts on receptacle
Cable mounted receptacles K/KE KS/KSE		Exceptions Multipole high voltage Mixed high voltage
Panel mounted cable receptacles DK/DKE DKBE		
Panel mounted receptacles D DEU/DEE DB DBEU/DBEE DBP DBPU/DBPE DBPLU/ DBPLE DG/DGP DBPC WDE		
Panel mounted plugs SF SFU/SFE SFPU/SFPE		

Part numbering

Contact configuration	Options*	Cable clamp sets for cable mounted plugs & receptawcles
056	130	+
	See page B2-39 for multipole low voltage / See page B3-24 for others	
056	130	Not applicable as panel mounted
	Natural chrome housing, PEEK contact blocks with solder contacts, keying code 1 and clamp nut without bend relief.	
	Natural chrome housing, PEEK contact blocks with solder contacts and keying code 1.	
▼	▼	▼
Three-digit number specific for each pin layout	Specific suffix corresponding to selected options	Below cable clamp sets should be ordered separately
	Housing color Natural chrome Black chrome	Multipole low voltage Triax Example: S 102 A056 - 130 +
	Contact block insulating material PEEK PTFE PBT	Clamp set ordering line E3 102.5/2.0 See page B2-39
	Contact type Solder Crimp PCB	Below cable clamp sets are included with connector
	Mechanical coding of the contact block	Coax low voltage Coax high voltage
	Clamp nut type & color	Multipole high voltage Mixed high voltage Mixed coax
	Other options	Shielded (S) or Environmental (E) cable clamp set diameter should be added to the connector part number separated by ø. Examples: for Shielded S clamp sets K 103 A002-600 ø6.2 or environmental E clamp sets KE 103 A002-600 ø6.2
		Insulating clamp set ø (104, 105 and 106 Series) should be added to the connector part number separated by ø and followed by UI (Unshielded Insulated). Example: S 104 A062-130 ø6.6 - UI

RELATED ITEMS

Accessories	Tooling
	
Example 102.785 Protective sleeve	Example TX00.240 Crimping tool
▼	▼
Cable bend reliefs Protective sleeves Soft caps Metal caps Spacers Washers Mounting nuts	Spanners / Wrenches Crimping tools Tools for crimp contacts and high voltage contacts

See *Accessories* section, page B 6-2.

See *Tooling* section, page B 6-19.

References	Multipole low voltage	Multipole high voltage	Coax low voltage	Coax high voltage	Triax	Mixed high voltage	Mixed coax	relevant information (page)
102 A 001			●					B 3-22
102 A Z 002			●					B 3-22
102 A 014					●			B 4-18
102 A 017			●					B 3-22
102 A Z 018				●				B 3-34
102 A 021					●			B 4-18
102 A Z 025				●				B 3-34
102 A Z 051	●							B 2-27
102 A Z 052	●							B 2-27
102 A Z 053	●							B 2-27
102 A Z 054	●							B 2-27
102 A Z 056	●							B 2-27
102 A Z 059	●							B 2-27
103 A Z 001			●					B 3-22
103 A Z 002			●					B 3-22
103 A 015					●			B 4-18
103 A Z 023				●				B 3-34
103 A 026			●					B 3-22
103 A Z 051	●							B 2-28
103 A Z 052	●							B 2-28
103 A Z 053	●							B 2-28
103 A Z 054	●							B 2-28
103 A Z 056	●							B 2-28
103 A Z 057	●							B 2-28
103 A Z 058	●							B 2-28

References	Multipole low voltage	Multipole high voltage	Coax low voltage	Coax high voltage	Triax	Mixed high voltage	Mixed coax	relevant information (page)
103 A Z 062	●							B 2-28
1031 A Z 010	●							B 2-28
1031 A Z 012	●							B 2-28
1031 A Z 019	●							B 2-28
104 A 002			●					B 3-23
104 A Z 010				●				B 3-34
104 A Z 037	●							B 2-29
104 A Z 040	●							B 2-29
104 A Z 051	●							B 2-29
104 A Z 053	●							B 2-29
104 A Z 054	●							B 2-29
104 A Z 055	●							B 2-30
104 A Z 056	●							B 2-30
104 A 060			●					B 3-23
104 A Z 062		●						B 2-58
104 A Z 065	●							B 2-29
104 A Z 066	●							B 2-30
104 A 078							●	B 5-16
104 A Z 083						●		B 5-24
104 A Z 086	●							B 2-30
104 A Z 087	●							B 2-29
104 A Z 092	●							B 2-30
104 A 093							●	B 5-16
104 A 124	●							B 2-30

Contact configurations

References	Multipole low voltage	Multipole high voltage	Coax low voltage	Coax high voltage	Triax	Mixed high voltage	Mixed coax	relevant information (page)
105 A Z 002			●					B 3-23
105 A Z 004				●				B 3-34
105 A Z 005				●				B 3-34
105 A 020						●		B 5-24
105 A 036						●		B 5-24
105 A Z 038	●							B 2-32
105 A Z 039		●						B 2-58
105 A Z 049				●				B 3-34
105 A Z 051	●							B 2-31
105 A Z 052	●							B 2-31
105 A Z 053	●							B 2-31
105 A Z 054	●							B 2-31
105 A 057		●						B 2-58
105 A Z 058	●							B 2-32
105 A 060						●		B 5-24
105 A Z 062	●							B 2-32
105 A Z 069	●							B 2-32
105 A 074							●	B 5-16
105 A 087	●							B 2-31
105 A 089							●	B 5-16
105 A Z 090			●					B 3-23
105 A Z 093	●							B 2-32
105 A 095							●	B 5-16
105 A Z 101	●							B 2-31
105 A Z 102	●							B 2-32

References	Multipole low voltage	Multipole high voltage	Coax low voltage	Coax high voltage	Triax	Mixed high voltage	Mixed coax	relevant information (page)
105 A Z 104	●							B 1-32
105 A 108				●				B 3-34
105 A Z 110	●							B 2-32
105 A 112						●		B 5-24
105 A Z 124	●							B 2-31
105 A 127	●							B 2-32
106 A Z 003	●							B 2-33
106 A Z 007	●							B 2-33
106 A Z 013		●						B 2-58
106 A 014						●		B 5-24
106 A Z 015	●							B 2-33
106 A Z 017	●							B 2-33
106 A Z 018	●							B 2-33
106 A Z 019	●							B 2-33
107 A Z 003				●				B 3-34
107 A 004				●				B 3-34
107 A Z 013	●							B 2-34
107 A Z 015	●							B 2-34
107 A Z 017				●				B 3-34
107 A Z 018	●							B 2-34
107 A Z 023	●							B 2-34
107 A 034		●						B 2-58
107 A Z 051	●							B 2-34
107 A Z 052	●							B 2-34

All dimensions and images shown are in millimeters and are for reference only.

PANEL CUT-OUTS

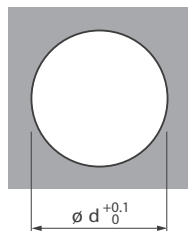

The dimension of panel cut-outs varies according to the body style and size of the panel mounted connector.

Refer to the tables aside and below for more details.

Check details in technical drawings on our web site:

www.fischerconnectors.com

PANEL MOUNTED PLUGS

Series	SF	SFU/SFE	SFPU /SFPE
	ø d		
102	9.1	9.1	9.1
103	12.1	12.1	12.1
1031	14.1	14.1	14.1
104	15.1	16.1	16.1
105	16.1	20.1	20.1
106	30.2	-	-
107	32.2	-	-

PANEL MOUNTED RECEPTACLES

Series	D	DEU DEE	DB	DBEU DBEE	DBP	DBPU DBPE	DBPLU DBPLE	DG DGP	DBPC	WDE
	ø d									
102	9.1	10.1 ¹⁾	9.1	9.1	9.1	9.1	10.1	9.1	9.1	9.1
103	12.1	14.1	12.1	14.1	12.1	14.1	14.1	12.1	12.1	12.1
1031	14.1	14.1	-	14.1	14.1	14.1	15.1	14.1	14.1	-
104	15.1	16.1	16.1	16.1	15.1	16.1	16.1	15.1	-	15.1
105	18.1	20.1	18.1	18.1	18.1	20.1	20.1	18.1	-	20.1
106	32.2	34.2	-	32.2	-	-	-	32.2	-	32.2
107	35.2	36.2	-	35.2	-	35.2	-	-	-	36.2

¹⁾Coax High Voltage DEE 102 AZ 025: ø11.1 (see page B3-33).

PANEL MOUNTED CABLE RECEPTACLES

Series	DK	DKBE	DKE
	ø d		
102	9.1	12.1	10.1
103	12.1	15.1	14.1
1031	-	16.1	-
104	15.1	18.1	16.1
105	18.1	22.1	20.1
106	32.2	34.2	30.2
107	35.2	38.2	35.2

All dimensions and images shown are in millimeters and are for reference only.

MATERIAL & SURFACE TREATMENTS

Metal parts

The standard Fischer Connectors shells are nickel plated brass with natural (silver) chrome finish. Black chrome finish is available as an option; see Options pages B2-35 and B3-26. Internal piece parts are nickel plated brass. When warranted by an extreme environment, in most cases stainless steel can be substituted for all metal parts.

Metal parts	Material			Finish	
	Designation	ISO	Standard	Designation	Standard
Shell (Housing), clamp nut, decorative slotted nut	Brass	CuZn39Pb3	CW614N / UNS C 38500	Chrome over Nickel	SAE-AMS2460
Plug body, cable clamp, inner sleeve, spacers and rings, nuts and washers	Brass	CuZn39Pb3	CW614N / UNS C 38500	Nickel	SAE-AMS-QQ-N-290 / SAE-AMS2404
Contacts	Male (solder)	Brass	CuZn39Pb3	1 µm Gold over Nickel	MIL-DTL-45204D / Type 1 + ASTM B488
	Female, Male (crimp)	Bronze	CuSn4Zn4Pb4		

Other material and surface treatments are available on request.

Insulator and sealing

Contact blocks and other insulators for our standard connectors are manufactured from high performance engineering plastic materials. The standard materials of each connector series are listed under Electrical & Contact configurations in pages B2-2 through B5-2. Ceramics and other dielectrics are available on special order.

Insulator and sealing	International symbol	Flammability
Insulator	PEEK - PTFE - PBT	UL 94 V-O
Interface O-rings (receptacles)	FPM (Viton®) / EPDM	-
Sealant material - IP68 (receptacles) - Hermetic	Silicon compound Epoxy compound	UL 94 V-O UL 94 HB
Cable sealing (plugs) - IP68	TPE-S	UL 94 HB

Our products are RoHs compliant and conform with the EC Directives 2002/95/EC.

Elastomer seals

Sealed connectors are fitted with O-rings and cable sealing gaskets.

The standard materials are:

FPM (Viton®) for O-rings

TPE (Thermoplastic Elastomers) for cable seals, protective sleeves and strain reliefs.

Compound and trade name	Chemical name	Excellent resistance to
FPM (Viton®)	Fluoro Elastomer	Acids, weather, ozone, fuels, mineral and silicone oils, high vacuum, gamma rays
EPDM, EPM or EPR	Ethylene Propylene Diene Elastomer	Alcohol, weather, hot water, vapor, brake fluids, detergents, gamma rays
TPE-S, TPE-O (Thermoplastic Elastomer)	Styrene-Ethylene-Butadiene-Styrene	Very resistant, except to aromated and chlorinated hydrocarbons

Please note that as an elastomer reaches its lower temperature limit, it becomes rigid and loses the flexibility required for connector mating and unmating. If sealed connectors have to be manipulated at low temperatures, the O-rings in the mating area has to be of a material with a considerably lower temperature limit.

The elastomers listed below represent presently available materials, which Fischer Connectors can substitute when required by an application. Not all materials are available in all shapes and sizes so please check with us for details.

All dimensions and images shown are in millimeters and are for reference only.

ENVIRONMENTAL & MECHANICAL DATA

Characteristic	Product type	Value	Standard
Sealing performance	Unsealed connectors (mated)	IP50	IEC 60529
	Plugs (mated) with general purpose sealed clamps ¹⁾	IP68 IP69	
	Receptacles "U" body style	IP68	
	Receptacles "E" body style	Hermetic: Tested: 10^{-8} mbar l/sec.	IEC 60068-2-17 test Qk method 3, alternative b
IP69		IEC 60529	
Operating temperature range	See details on page A 15	See details on page A 15	IEC 60512-6-11 i+j / IEC 60068-2-14-Nb
Corrosion resistance ³⁾		Salt mist, 1,000 hours, 5% salt solution, 35°C	IEC 60068-2-11 test Ka MIL-STD-202 method 101 EIA-364-26
Endurance		10,000 mating cycles	IEC 60512-9-1 / EIA-364-09
Vibration		10 to 2000 Hz, 1.5 mm or 15g, 12 sweep cycles per axis, 20 minutes per 10-2000-10 Hz sweep cycle, no discontinuity > 1us	MIL-STD-202 method 204 condition B
Radiation resistance ²⁾	Unsealed connectors	PEEK: 10 ⁷ Gy(=1000M Rads)	
	Sealed receptacles "E"	FPM (Viton®) O-rings 10 ⁵ Gy (=10M Rads)	

¹⁾ The sealing performance can be affected by the long term quality of the cable.

²⁾ For information only. Not tested by Fischer Connectors.

³⁾ Plug and receptacle in mated position or with cap when unmated. For Brass connectors only.

Aluminum version not recommended for Marine use. Preserved mechanical and electrical functionality. Visual aspect might be altered.

Most of our connectors are completely sterilizable in autoclave, Cidex®, EtO, gamma radiation, Steris® or Sterrad®. Please contact us for more details. For more information visit: www.fischerconnectors.com.

ELECTRICAL DATA

Characteristic	Contact size	Typical values	Standard
Contact resistance 10,000 mating cycles	ø 0.5 mm	5.0 mΩ	IEC 60512-2-1, Test 2a IEC 60512-2-2, Test 2b
	ø 0.7 mm	5.0 mΩ	
	ø 0.9 mm	4.0 mΩ	
	ø 1.3 mm	2.5 mΩ	
	ø 1.6 mm	2.5 mΩ	
	ø 2.3 mm	2.5 mΩ	
	ø 3.0 mm	1.5 mΩ	
Insulation resistance		> 10 ¹⁰ Ω	IEC 60512-3-1-3a Method C

OPERATING TEMPERATURES

The temperature ranges quoted by the manufacturers of the plastic materials are usually the absolute maximum values. When exposed to the mechanical and electrical stresses present in a connector, these values are often unrealistic. If a composite connector system including accessories is used, then the item

with the lowest temperature performance will dictate the operating temperature limit of the system. The table below shows our recommended operating temperature ranges.

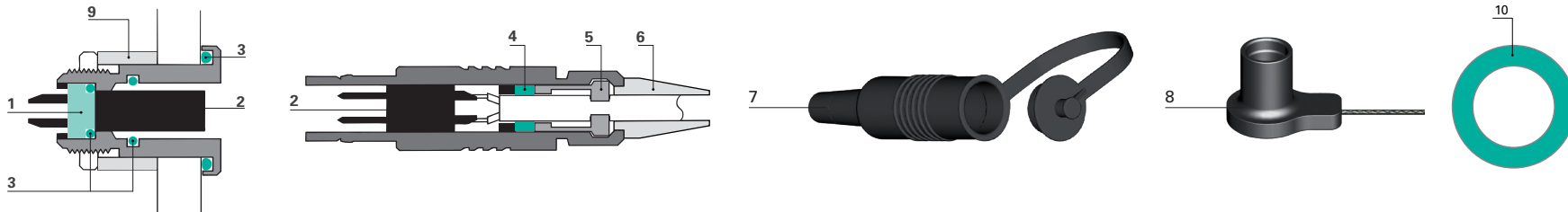

Ref.	Component	Material	Operating temperatures
1	Sealant	"U" Type	-55°C to +200°C
		"E" Type	-65°C to +150°C
2	Insulator	PEEK	-65°C to +250°C
		PTFE (Teflon®)	-65°C to +160°C
		PBT	-65°C to +135°C
3	Standard O-rings	FPM (Viton®)	-20°C to +200°C ¹⁾
	Interface O-rings (option)	EPDM	-50°C to +160°C ²⁾
4	Cable clamp seal	TPE	-70°C to +130°C
5	Cable clamp	Standard Brass	-40°C to +100°C
		High Voltage Connectors POM	-60°C to +100°C
6	Cable strain relief	TPE	-60°C to +100°C
		405 only	-60°C to +180°C
7	Protective Boots	TPE	-60°C to +100°C
8	Sealing Caps	Metallic Plug: Brass with FPM O-ring	-20°C to +200°C ¹⁾
		Receptacle Brass with NBR O-ring	-30°C to +110°C ¹⁾
		Plastic POM with FPM O-ring	-20°C to +100°C ¹⁾
		Soft Caps TPE	-55°C to +85°C
9	Panel Spacer	Aluminium	
10	Color Coding Washer	PP	-20°C to +60°C

¹⁾ Minimum mating temperature: 0°C.

²⁾ Minimum mating temperature: -20°C.



All dimensions and images shown are in millimeters and are for reference only.

MECHANICAL CODING

For easy connect / disconnect operations

Our contact blocks are engineered with arc-shape metal guides, which ensure precise alignment of connectors during the mating process.



This guiding mechanism provides:

- Increased safety and user friendliness by preventing misconnection.
- Easy mating cycles, can be blind-mated.
- Increased equipment life span by optimally protecting the contacts.

Keying codes options

All multipole body styles are mechanically coded. Code 1 is the standard, but other codes can be requested.

	Code 1	Code 2	Code 3
Receptacle			
Plug			

Other keying codes are available on request, please contact us.
Images are here for information only and do not reflect always the reality.

Keying codes options

All multipole body styles are mechanically coded. Code 1 is the standard, but other codes can be requested.

B2

CHAPTER



FISCHER CORE SERIES **BRASS** **MULTIPOLE**

- LOW VOLTAGE.....B2-2
- HIGH VOLTAGE.....B2-50



B2-2 / B2-49

MULTIPOLE LOW VOLTAGE



PLUGS



CABLE MOUNTED

- Body styles (S/SC; SOV; SA; SV; SS/SSC; WSO) B 2-3
- Technical dimensions B 2-4



PANEL MOUNTED

- Body styles (SF; SFU/E; SFPU/E) B 2-17
- Technical dimensions B 2-18

RECEPTACLES



CABLE MOUNTED

- Body styles (K/KE; KS/KSE) B 2-7
- Technical dimensions B 2-8



PANEL MOUNTED

- Body styles (D; DEU/E; DB; DBEU/E; DBP; DBPU/E; DBPLU/E; DG; DGP; DBPC; WDE) B 2-9
- Technical dimensions B 2-11



PANEL MOUNTED CABLE

- Body styles (DKBE; DK; DKE) B 2-20
- Technical dimensions B 2-21

FOR ALL MULTIPOLE LOW VOLTAGE

- Electrical & contact configurations B 2-23
- Options B 2-35
- Cable clamp sets B 2-39
- Accessories B 6-2
- Tooling B 6-19
- Technical information B 1-13
- Product specifications A-5

This catalog covers our standard connector solutions. For specific requests, including hybrid or custom connectors, please contact your local sales representative.

PLUGS

CABLE MOUNTED



Body style		S	SC	SOV	SA	SV	SS	SSC	WSO	References to detailed information
Protection	Unsealed (IP50)	●	●	●	●	●	●	●	●	Sealing categories, page A-6
	Sealed up to IP68	●	●	●	●	●	●	●	●	
Locking system	Friction			●						Locking systems, page A-5
	Push-pull	●			●	●	●		●	
	Quick-release		●					●		
	Lanyard				●					
Contacts	Tamperproof					●				Electrical & configurations, page B2-23
	Crimp	●	●	●	●	●	●	●	●	
Housing color	Solder	●	●	●	●	●	●	●	●	Options, page B2-35
	Natural chrome	●	●	●	●	●	●	●	●	
Design	Black chrome	●	●	●	●		●	●	●	Body styles, chapter B1-2
	Shortened body						●	●		
Cabling	Straight	●	●	●	●	●	●	●		
	Right-angle						●	●	●	
	Cable clamp sets	●	●	●	●	●			●	
Accessories	Overmoldable						●	●		Cable clamp sets, page B2-39
	Heat shrinkable						●	●		
	Cable bend reliefs	●	●	●	●	●			●	
Size	Protective sleeves	●	●	●						Accessories, section B6-2
	Sealing caps	●	●	●	●	●	●	●	●	
	102 Series	●	●	●	●	●	●	●	●	
Size	103 Series	●	●	●	●	●	●	●	●	Technical dimensions, page B2-4 For more information visit our website www.fischerconnectors.com/technical
	1031 Series	●	●	●	●	●	●	●	●	
	104 Series	●	●	●	●	●	●	●	●	
	105 Series	●	●	●	●	●	●	●	●	
	106 Series	●				●				
107 Series	●				●					

MULTIPOLE LOW & HIGH VOLTAGE

PLUGS

CABLE MOUNTED

S/SC

BODY STYLES

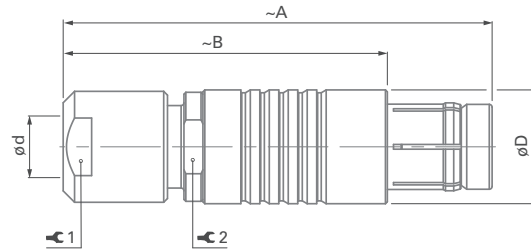

Series	A	B	D	d max		1	Torque 1 [Nm]	2
				Unsealed	Sealed			
102	36	26	9	4.7	4.3	7	0.6	7
103	46	35	12	6.7	6.2	10	1.0	10
1031	48	38	13	7.2	6.7	12	1.5	11
104	50	38	15	8.7	8.7	12	2.0	13
105	62	47	18	10.7	10.7	15	3.5	16
106	80	55	28	19.2	19.2	22	8.0	-
107	110	85	34	22.7	22.7	32	10.0	32

SOV

BODY STYLE

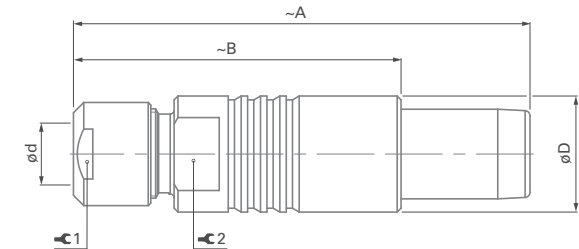

Series	A	B	D	d max		1	Torque 1 [Nm]	2
				Unsealed	Sealed			
102	36	26	9	4.7	4.3	7	0.6	7
103	46	35	12	6.7	6.2	10	1.0	10
1031	48	38	13	7.2	6.7	12	1.5	11
104	50	38	15	8.7	8.7	12	2.0	13
105	62	47	18	10.7	10.7	15	3.5	16
106	Please contact us for additional information							
107								

PLUGS

CABLE MOUNTED

SA
BODY STYLE

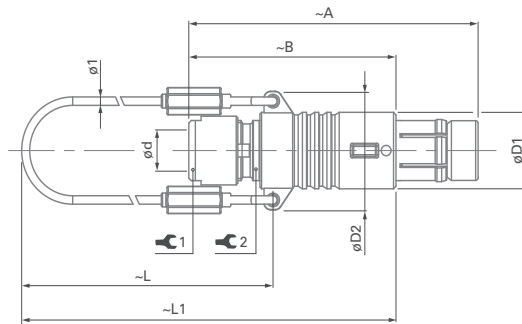

Series	A	B	D1	D2	L	L1	d max		Wrench 1	Torque 1 [Nm]	Wrench 2
							Unsealed	Sealed			
102	36	26	9	14	50	65	4.7	4.3	7	0.6	7
103	46	35	12	17	60	77	6.7	6.2	10	1.0	10
1031	48	38	13	18	55	75	7.2	6.7	12	1.5	11
104	50	38	15	21	65	84	8.7	8.7	12	2.0	13
105	62	47	18	25	70	94	10.7	10.7	15	3.5	16
106	Please contact us for additional information										
107											

SV
BODY STYLE

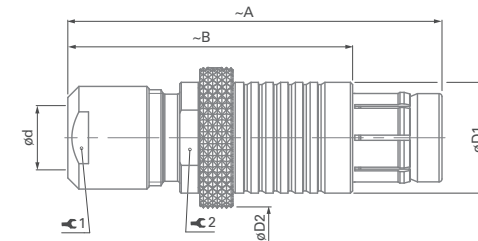

Series	A	B	D1	D2	d max		Wrench 1	Torque 1 [Nm]	Wrench 2	
					Unsealed	Sealed				
102	36	26	9	11	4.7	4.3	7	0.6	-	
103	46	35	12	13	6.7	6.2	10	1.0	-	
1031	Please contact us for additional information									
104	50	38	15	20	8.7	8.7	12	2.0	13	
105	62	47	18	22	10.7	10.7	15	3.5	16	
106	80	55	30	35	19.2	19.2	22	8.0	-	
107	110	85	34	38	22.7	22.7	32	10.0	32	

Torque [Nm] are recommended values that may be influenced by the characteristics of the cable jacket. Tests have to be made to evaluate the exact values. To secure the cable clamp nut, we recommend the use of thread locking adhesive.

PLUGS

CABLE MOUNTED

SS/SSC

BODY STYLES

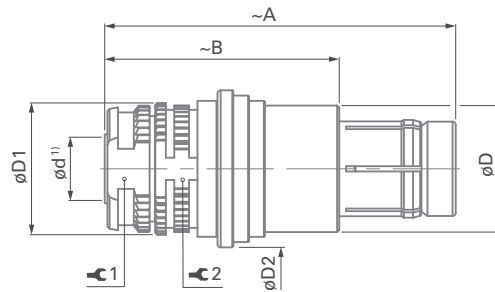

Series	A	B	D	D1	D2	d max ¹⁾	⚙ 1	Torque 1 [Nm]	⚙ 2
102	30	20	9.0	9.5	12.0	3.8	7	0.4 – 0.6	8
103	33	22	12.0	12.5	15.0	6.0	10	0.8 – 1.0	11
1031	33	23	12.4	13.0	15.5	6.2	10	0.8 – 1.0	11
104	38	26	15.0	15.3	18.0	8.0	12	1.5 – 2.0	13
105	44	29	18.0	18.4	21.2	10.0	15	1.5 – 2.0	16
106	Please contact us for additional information								
107									

¹⁾ Max. cable diameter below shield.

WSO

BODY STYLE

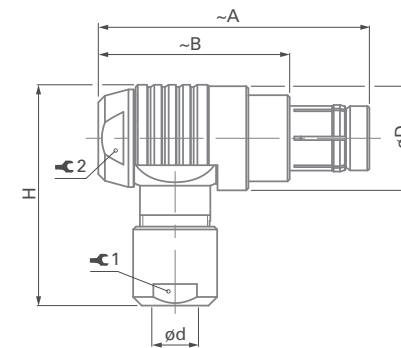



Series	A	B	D	H	d max		⚙ 1	Torque 1 [Nm]	⚙ 2	Torque 2 [Nm]
					Unsealed	Sealed				
102	33	23	12	25	4.7	4.3	7	0.6	8	1.0
103	38	27	15	31	6.7	6.2	10	1.0	11	1.3
1031	39	29	17	33	7.2	6.7	12	1.5	12	2.0
104	45	32	19	37	8.7	8.7	12	2.0	14	2.5
105	53	38	23	45	10.7	10.7	15	3.5	17	3.5
106	Please contact us for additional information									
107										

WSO is available for different cable orientations. When ordering, choose which suffix to use in cable orientations figure.

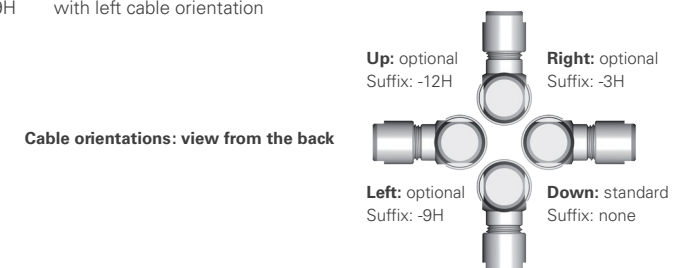
Example: WSO 102 A056 -130+ with standard down cable orientation
 WSO 102 A056 -130 -9H with left cable orientation



RECEPTACLES

CABLE MOUNTED						
Body style		K	KE	KS	KSE	References to detailed information
Protection	Unsealed (IP50)	●		●		Sealing categories, page A-6
	Sealed up to IP68		●		●	
Contacts	Crimp	●	●	●	●	Electrical & contact configurations, page B2-23
	Solder	●	●	●	●	
Housing	Natural chrome	●	●	●	●	Options, page B2-35
	Black chrome	●	●	●	●	
	Shortened body			●	●	
Design	Straight			●	●	Body styles, chapter B 1-3
	Right-angle			●	●	
Cabling	Cable clamp sets	●	●			Cable clamp set, page B2-39
	Overmoldable			●	●	
	Heat shrinkable			●	●	
Accessories	Cable bend reliefs	●	●			Accessories, section B6-2
	Protective sleeves	●	●			
	Sealing caps	●	●	●	●	
Size	102 Series	●	●	●	●	Technical dimensions, page B2-8 For more information visit our website www.fischerconnectors.com/technical
	103 Series	●	●	●	●	
	1031 Series	●	●	●	●	
	104 Series	●	●	●	●	
	105 Series	●	●	●	●	
	106 Series	●	●			
	107 Series	●	●			

MULTIPOLE LOW & HIGH VOLTAGE

RECEPTACLES

CABLE MOUNTED

K/KE

BODY STYLES

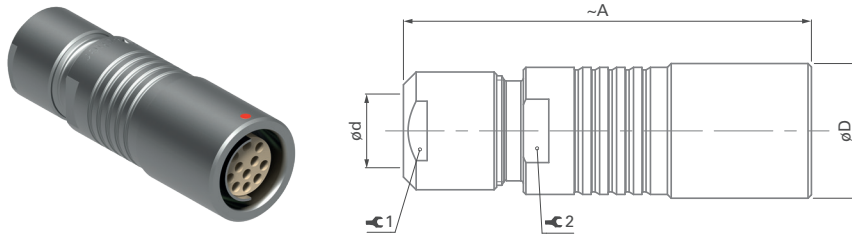

Series	A	D	d max		1	Torque 1 [Nm]	2
			Unsealed	Sealed			
102	35	10	4.7	4.3	7	0.6	7
103	43	13	6.7	6.2	10	1.0	10
1031	46	13.5	7.2	6.7	12	1.5	11
104	50	16	8.7	8.7	12	2.0	13
105	60	19	10.7	10.7	15	3.5	16
106	79	33	19.2	19.2	25	8	25
107	105	36	22.7	22.7	32	10	32

KS/KSE

BODY STYLES

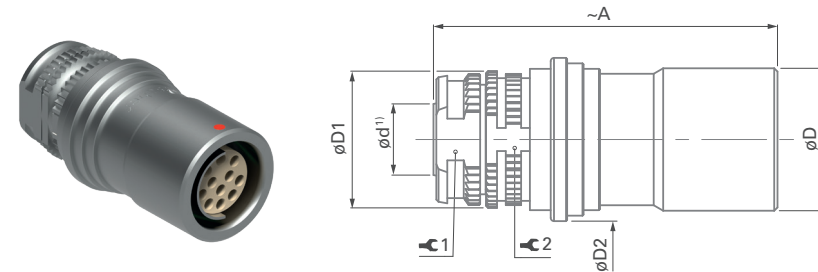

Series	A	D	D1	D2	d max	1	Torque 1 [Nm]	2
103	32	13.0	13.0	15.0	6.0	10	0.8 – 1.0	11
1031	31	13.5	13.5	15.5	6.2	10	0.8 – 1.0	11
104	35	16.0	16.0	18.0	8.0	12	1.5 – 2.0	13
105	43	19.0	18.0	21.2	10.0	15	1.5 – 2.0	16
106	Please contact us for additional information							
107								

¹⁾ Max. cable diameter below shield.

Torque [Nm] are recommended values that may be influenced by the characteristics of the cable jacket. Tests have to be made to evaluate the exact values. To secure the cable clamp nut, we recommend the use of thread locking adhesive.







RECEPTACLES

PANEL MOUNTED



Body style		D	DEU	DEE	DB	DBEU	DBEE	DBP	References to detailed information
Protection	Unsealed (IP50)	●			●			●	Sealing categories, page A-6
	Sealed up to IP68		●	●		●	●		
	Hermetic			●			●		
Contacts	Crimp	●			●			●	Electrical & contact configurations, page B 2-23
	Solder	●	●	●	●	●	●	●	
	PCB	●	●	●	●	●	●	●	
Housing color	Natural chrome	●	●	●	●	●	●	●	Options, page B 2-35
	Black chrome	●	●	●	●	●	●	●	
Design	Right-angle								Body styles, chapter B1-3
	Flush	●	●	●				●	
	Front-projecting				●	●	●		
	Bulkhead feedthrough								
Assembly	Front-mounting	●	●	●	●	●	●		
	Rear-mounting							●	
Accessories	Sealing caps	●	●	●	●	●	●	●	Accessories, section B6-2
	Spacers		●	●					
	Color-coded washers	●			●			●	
	Grounding washers	●	●	●	●	●	●	●	
	Locking washers	●	●	●	●	●	●	●	
Size	102 Series	●	●	●	●	●	●	●	Technical dimensions, page B2-11
	103 Series	●	●	●	●	●	●	●	
	1031 Series	●	●	●	●	●	●	●	
	104 Series	●	●	●	●	●	●	●	For more information visit our website www.fischerconnectors.com/technical
	105 Series	●	●	●	●	●	●	●	
	106 Series	●		●			●	●	
	107 Series	●		●			●	●	

RECEPTACLES

PANEL MOUNTED										References to detailed information
Body style		DBPU	DBPE	DBPLU	DBPLE	DG	DGP	DBPC	WDE	
Protection	Unsealed (IP50)					•	•	•		Sealing categories, page A-6
	Sealed up to IP68	•	•	•	•				•	
	Hermetic		•		•				•	
Contacts	Crimp					•				Electrical & contact configurations, page B2-23
	Solder	•	•	•	•	•				
	PCB	•	•	•	•		•	•		
Housing color	Natural chrome	•	•	•	•	•	•	•	•	Options, page B2-35
	Black chrome	•	•	•	•	•	•	•		
Design	Right-angle							•		Body styles, chapter B 1-3
	Flush	•	•			•	•	•	•	
	Front-projecting			•	•	•	•		•	
	Bulkhead feedthrough								•	
Assembly	Front-mounting					•	•		•	
	Rear-mounting	•	•	•	•	•	•	•		
Accessories	Sealing caps	•	•	•	•	•	•	•	•	Accessories, section B6-2
	Spacers								•	
	Color-coded washers					•	•	•		
	Grounding washers	•	•	•	•	•	•	•		
	Locking washers	•	•	•	•	•	•	•		
Size	102 Series	•	•	•	•	•	•	•	•	Technical dimensions, page B2-13 For more information visit our website www.fischerconnectors.com/technical
	103 Series	•	•	•	•	•	•	•	•	
	1031 Series	•	•	•	•	•	•	•		
	104 Series	•	•	•	•	•	•		•	
	105 Series	•	•	•	•	•	•		•	
	106 Series					•	•		•	
	107 Series		•						•	

For WDE 106 the interface is not sealed (no interface O.-ring).

RECEPTACLES

PANEL MOUNTED

D

BODY STYLE

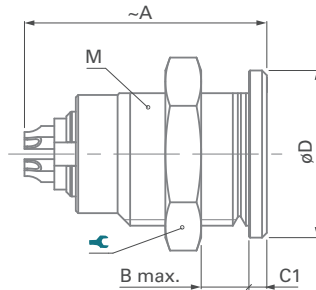

Series	A	B max.	C1	D	M	⌘	Torque [Nm]
102	19	9	1.5	11	9x0.5	11	1.3
103	23	8	1.5	14	12x1	14	2.5
1031	25	10	2.0	16	14x1	17	3.0
104	25	11	2.2	19	15x1	17	4.0
105	32	15	2.0	22	18x1	22	6.0
106	50	18	3.0	37	32x1	TX00.106	15
107	46	18	4.0	40	35x1	TX00.107	16

Torque [Nm] are recommended values that may be influenced by the quality of the panel surface under the nut. Tests have to be made to evaluate the exact values.

DEU/DEE

BODY STYLES

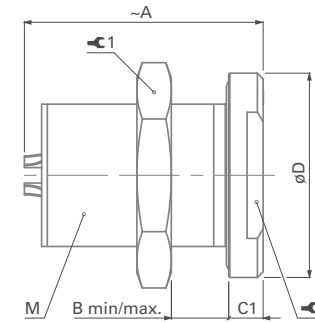

Series	A	B min/max.	C1	D	M	⌘ 1	Torque 1 [Nm]	⌘ 2
102	20	8/10	2.5	14	9x0.5	11	1.3	11
103	23	0/12	3.0	18	14x1	17	3.0	14
1031	25	0/12	3.0	19	14x1	17	3.0	15
104	25	0/15	4.0	22	16x1	19	4.5	17
105	33	10.5/18	4.0	27	20x1	25	6.5	-
106	50	19/24	5.0	41	32x1	TX00.106	15	-
107	47	19.2/22	5.0	45	35x1	TX00.107	16	-

RECEPTACLES

PANEL MOUNTED

DB

BODY STYLE

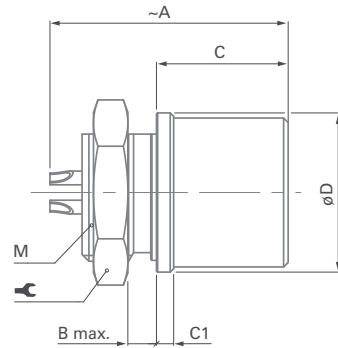

Series	A	B max.	C	C1	D	M	⌘	Torque [Nm]
102	18	3	11.0	1.0	11	9x0.5	11	1.3
103	21	4	11.5	1.5	14	12x1	14	2.5
1031	Please contact us for additional information							
104	26	3	14.5	2.5	19	16x1	19	4.5
105	33	7	19.0	2.0	22	18x1	22	6.0
106	Please contact us for additional information							
107	Please contact us for additional information							

DBEU/DBEE

BODY STYLES

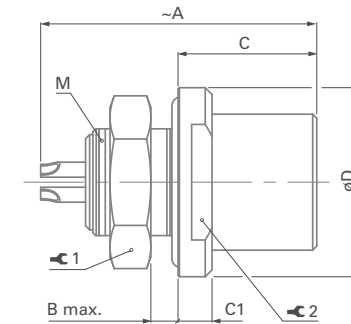
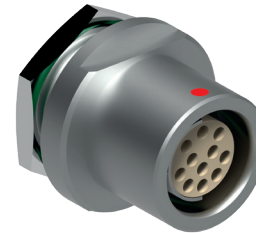

Series	A	B max.	C	C1	D	M	⌘ 1	Torque 1 [Nm]	⌘ 2
102	20	3.5	10.2	2.5	14	9x0.5	11	1.3	11
103	23	4.0	13.0	3.0	18	14x1	17	3.0	14
1031	24	4.0	12.0	3.0	19	14x1	17	3.0	15
104	30	3.5	16.0	4.0	22	16x1	19	4.5	17
105	32	5.0	19.0	4.0	27	18x1	22	6.0	22
106	50	6.5	25.5	7.0	40	32x1	TX00.106	15	-
107	47	5.0	24.0	5.0	45	35x1	TX00.107	16	38

Torque [Nm] are recommended values that may be influenced by the quality of the panel surface under the nut. Tests have to be made to evaluate the exact values.

RECEPTACLES

PANEL MOUNTED

DBP

BODY STYLE

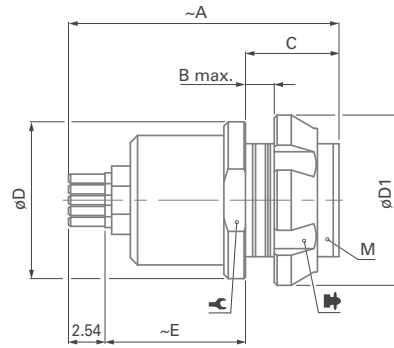

DBPU/DBPE

BODY STYLES

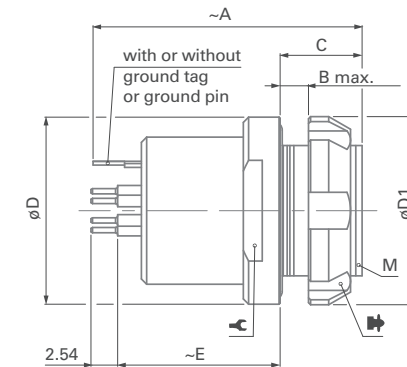

Series	A	B max.	C	D	D1	E	M	⌀	⌀ ¹⁾	Torque [Nm]
102	20	3.5	6.5	11	12	10.0	9x0.5	10	TC00.000	1.3
103	23	4.0	8.0	14	15	12.0	12x1	-	TF00.001	2.5
1031	23	3.0	7.0	16	18	13.0	14x1	-	TG00.001	3.0
104	26	5.0	9.0	19	19	11.5	15x1	-	TK00.000	4.0
105	30	12.0	17.0	22	23	10.0	18x1	-	TP00.011	6.0
106	Please contact us for additional information									
107	Please contact us for additional information									

Series	A	B max.	C	D	D1	E	M	⌀	⌀ ¹⁾	Torque [Nm]
102	20	3.5	6.5	14	12	11.5	9x0.5	11	TC00.000	1.3
103	26	3.0	7.8	18	18	15.5	14x1	15	TG00.001	3.0
1031	23	3.0	7.0	19	18	13.0	14x1	15	TG00.001	3.0
104	26	4.0	8.0	22	20	15.5	16x1	17	TK00.002	4.5
105	30	5.0	10.0	27	25	18.0	20x1	-	TP00.005	6.5
106	Please contact us for additional information									
107	Please contact us for additional information									

¹⁾ Assembly tool for decorative slotted nut, see Tooling section, page B 6-20, for details.

Torque [Nm] are recommended values that may be influenced by the quality of the panel surface under the nut. Tests have to be made to evaluate the exact values.



RECEPTACLES

PANEL MOUNTED

DBPLU/DBPLE

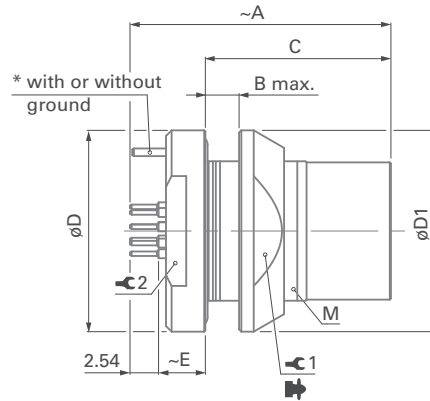
BODY STYLES



Series	A	B max.	C	D	D1	E	M	 ¹⁾	 1	Torque 1 [Nm]	 2
102	21	4.5	14.2	14	13	3.6	10x0.5	TC00.007	11	1.5	11
103	24	5.0	16.5	18	18	4.2	14x1	TG00.001	15	3.0	15
1031	23	5.5	16.0	19	20	4.2	15x1	TK00.000	17	4.0	15
104	27	6.5	18.5	22	20	5.0	16x1	TK00.002	17	4.5	17
105	31	7.0	22.5	27	25	5.5	20x1	TP00.005	22	6.5	22
106	Please contact us for additional information										
107	Please contact us for additional information										



- * – Pin for PCB contacts versions; all Series.
- Tag for solder contact versions; Series 103 to 107.
- Barrel for solder contact versions; Series 102.

¹⁾ Assembly tool for decorative slotted nut, see Tooling section, page B 6-20 , for details.

DG/DGP

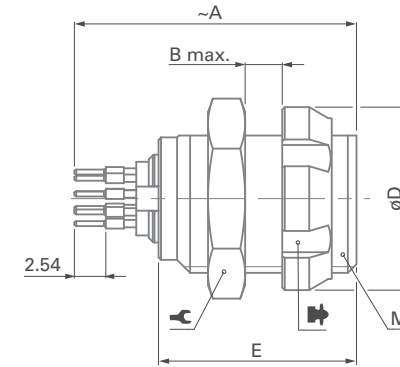
BODY STYLES



Series	A	B max.	D	E	M		 ¹⁾	Torque [Nm]
102	20	6	12	14	9x0.5	11	TC00.000	1.3
103	23	7	15	15	12x1	14	TF00.001	2.5
1031	23	7	18	18	14x1	17	TG00.001	3.0
104	26	9	19	18	15x1	17	TK00.000	4.0
105	30	15	23	24	18x1	22	TP00.011	6.0
106	Please contact us for additional information							
107	Please contact us for additional information							

RECEPTACLES

PANEL MOUNTED

DBPC

BODY STYLE

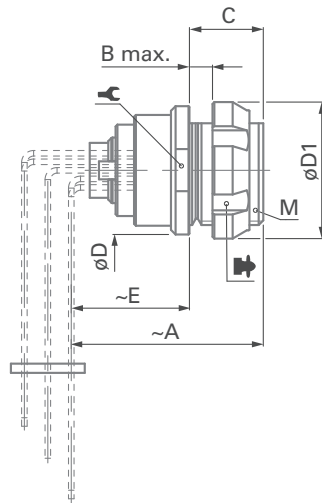

Series	A	B max.	C	D	D1	E ¹⁾	M			Torque [Nm]
102	20.0	3.5	6.5	11	12	13	9x0.5	10	TC00.000	1.3
103	22.0	4.0	8.0	14	15	13	12x1	-	TF00.001	2.5
1031	21.5	3.0	7.0	16	18	14	14x1	-	TG00.001	3.0

¹⁾Please refer to online technical drawings at www.fischerconnectors.com/technical for precise value and layout dimensions.

²⁾Assembly tool for decorative slotted nut, see Tooling section, page B 6-20, for details.

DBPC

MOUNTING CLAMP

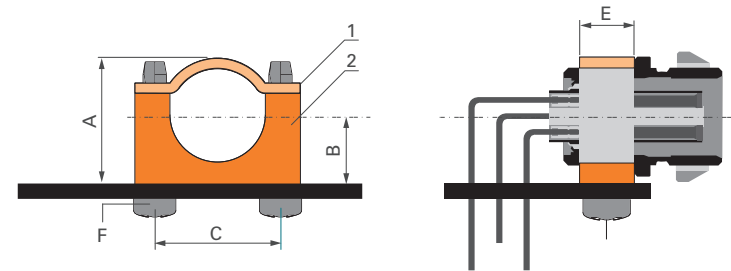

- Enables mounting directly to PCB with two screws
- Improves grounding of body to the PCB

Series	A	B	C	E	F	Part Number
102	11.5	6.0	12	3.8	∅ 2.2x13	102.1943
103	15.2	8.2	16	4.9	∅ 2.9x16	103.2253
1031	15.2	8.2	16	4.9	∅ 2.9x16	103.2253

Material:

- 1 - Nickel plated brass copper
- 2 - PBT

FEEDTHROUGH

PANEL MOUNTED

WDE : 102, 103 & 104 SERIES

BODY STYLE

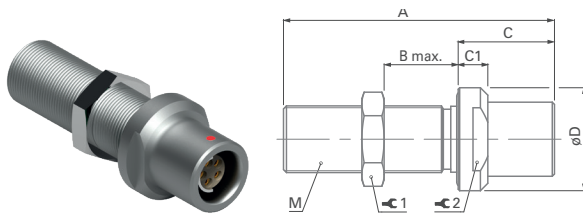

WDE : 105 SERIES

BODY STYLE

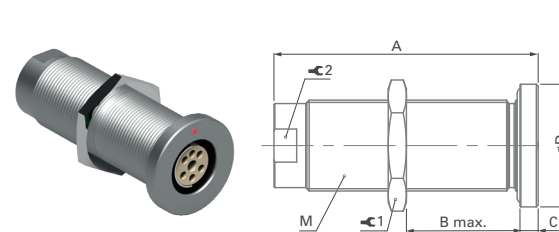

WDE : 106 & 107 SERIES¹⁾

BODY STYLE

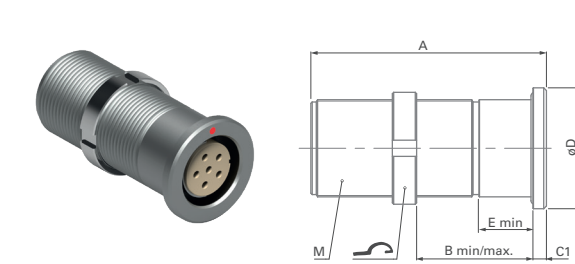

Series	A	B min/max	C	C1	D	E min	M	⚙️ 1 ²⁾	Torque 1 [Nm]	⚙️ 2
102	39	23	13	4	14	-	9x0.5	11	1.3	11
103	40	23	14	4	17	-	12x1	14	2.5	14
1031	Please contact us for additional information									
104	40	21	16	4	22	-	15x1	17	4.0	17
105	62	47	-	4	27	-	20x1	25	6.5	17
106 ^{1) 3)}	74	30/39	-	12	42	30	32x1	TX00.106	15	-
107 ¹⁾	92	20/76	-	5	45	20	36x1	TX00.107	17	-

The bulkhead feedthrough connector allows the passing of electrical signals and power through a panel via two cable plugs.

The "AZ" version of the feedthrough accepts a type "A" plug on the flange side and a type "Z" plug on the threaded end, which is typically oriented toward the interior of the chassis. In the version "ZA", the connections "A" and "Z" are inverted.

Dimension "B max" specifies the maximum panel thickness. For panels thinner than the unthreaded section "E min", we can provide spacers as shown in Accessories chapter B 6.

¹⁾ Feedthroughs of series 106 and 107 are supplied with slotted nuts. For nuts dimensions see Accessories section B 6-2.

²⁾ Assembly tool for side slotted nut, see Tooling section, section B 6-20, for details.

³⁾ For Series WDE 106 the interface is not sealed (no interface O-ring).

PLUGS

PANEL MOUNTED



Body style		SF	SFU	SFE	SFPU	SFPE	References to detailed information
Protection	Unsealed (IP50)	●					Sealing categories, page A-6
	Sealed up to IP68		●	●	●	●	
	Hermetic			●		●	
Contacts	Crimp	●					Electrical & contact configurations, B 2-23
	Solder	●	●	●	●	●	
	PCB	●	●	●	●	●	
Housing color	Natural chrome	●	●	●	●	●	Options, page B 2-35
	Black chrome	●	●	●	●	●	
Assembly	Front-mounting	●	●	●			Body style selection, chapter B 1-2
	Rear-mounting				●	●	
Accessories	Sealing caps	●	●	●	●	●	Accessories, section B 6-2
	Spacers						
	Color-coded washers	●					
	Insulating washers	●					
	Grounding washers	●	●	●			
Size	Locking washers	●	●	●	●	●	Technical dimensions, page B 2-18 For more information visit our website www.fischerconnectors.com/technical
	102 Series	●	●	●	●	●	
	103 Series	●	●	●	●	●	
	1031 Series	●	●	●	●	●	
	104 Series	●	●	●	●	●	
	105 Series	●	●	●	●	●	
	106 Series	●					
107 Series	●						

MULTIPOLE
LOW & HIGH
VOLTAGE

PLUGS

PANEL MOUNTED

SF

BODY STYLE

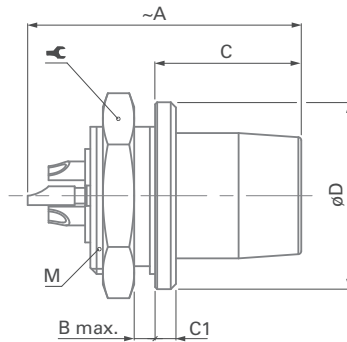

Series	A	B max.	C	C1	D	M	⚙	Torque [Nm]
102	20.0	3.5	11.0	1.0	10	9x0.5	11	1.3
103	23.5	3.0	12.5	1.5	14	12x1	14	2.5
1031	26.0	4.0	12.0	2.0	16	14x1	17	3.0
104	28.0	3.0	14.0	2.0	18	15x1	17	4.0
105	30.5	5.5	16.8	1.2	22	16x1	19	4.5
106	42.5	5.5	27.5	2.5	34	30x1	TX00.106	14
107	50.0	6.0	28.0	3.0	36	32x1	TX00.106	15

SFU/SFE

BODY STYLES

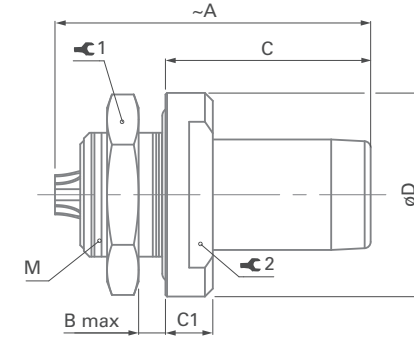
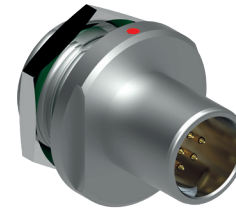

Series	A	B max.	C	C1	D	M	⚙1	Torque 1 [Nm]	⚙2
102	21	2.5	13.0	3.0	13	9x0.5	11	1.3	9
103	26	5.0	14.0	3.0	17	12x1	14	2.5	12
1031	26.5	4.0	13.7	3.7	19	14x1	17	3.0	12
104	28	7.5	15.5	3.5	22	16x1	19	4.5	17
105	32	6.0	19.0	4.0	27	20x1	25	6.5	-
106	Please contact us for additional information								
107									

PLUGS

PANEL MOUNTED

SFPU/SFPE

BODY STYLES

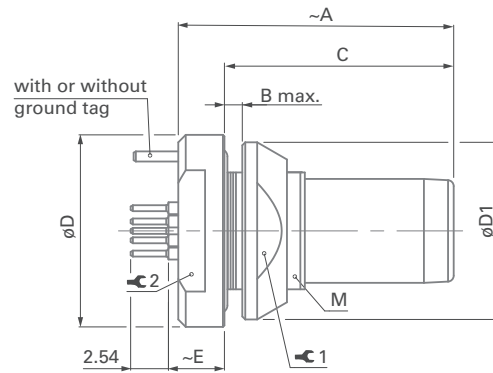

Series	A	B max.	C	D	D1	E	M	⌀ ₁	Torque 1 [Nm]	⌀ ₂
102	18.5	2.5	15.4	13	12	3.8	9x0.5	10	1.3	10
103	22.0	4.0	18.5	17	16	4.5	12x1	13	2.5	12
1031	21.5	4.0	18.0	19	18	4.5	14x1	15	3.0	15
104	25.5	6.0	22.0	22	20	4.2	16x1	17	4.5	17
105	29.0	5.0	25.0	27	25	5.0	20x1	22	6.5	19
106	Please contact us for additional information									
107										

Torque [Nm] are recommended values that may be influenced by the quality of the panel surface under the nut. Tests have to be made to evaluate the exact values.

All dimensions and images shown are in millimeters and are for reference only.

RECEPTACLES

PANEL MOUNTED CABLE



Body style		DKBE	DK	DKE	References to detailed information
Protection	Unsealed (IP50)		●		Sealing categories, section A-6
	Sealed up to IP68	●		●	
Contacts	Crimp	●	●	●	Electrical & contact configurations, page B 2-23
	Solder	●	●	●	
Housing color	Natural chrome	●	●	●	Options, page B2-35
	Black chrome	●	●	●	
Design	Flush		●		Body styles, chapter B 1-3
	Front-projecting	●		●	
Assembly	Panel mounted	●	●	●	Cable clamp sets, page B2-39
	Front-mounting		●	●	
	Rear-mounting	●			
Accessories	Cable clamp sets	●	●	●	Accessories, section B6-2
	Cable bend reliefs	●	●	●	
	Sealing caps	●	●	●	
	Spacers			●	
	Color-coded washers	●	●		
	Insulating washers				
	Grounding washers	●	●	●	
Size	Locking washers	●	●	●	Technical dimensions, page B2-21 For more information visit our website www.fischerconnectors.com/technical
	102 Series	●	●	●	
	103 Series	●	●	●	
	1031 Series	●			
	104 Series	●	●	●	
	105 Series	●	●	●	
	106 Series	●	●	●	
107 Series	●	●	●		

RECEPTACLES

PANEL REAR MOUNTED CABLE

DKBE

BODY STYLE

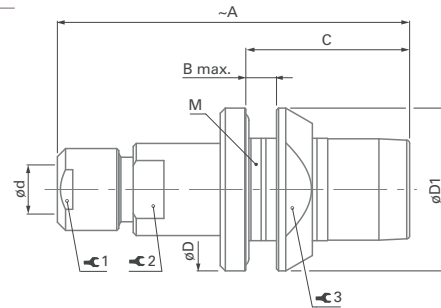

Series	A	B max.	C	D	d max	D1	M	⌘1	Torque 1 [Nm]	⌘2	⌘3	Torque 3 [Nm]
102	35	3.5	16.0	16	4.3	16	12x1	7	0.6	7	13	2.5
103	43	4.0	19.0	19	6.2	20	15x1	10	1.0	10	17	4.0
1031	46	4.0	18.0	21	6.7	20	16x1	12	1.5	11	17	4.5
104	50	5.0	22.5	23	8.7	23	18x1	12	2.0	13	20	6.0
105	60	5.0	26.0	28	10.7	27	22x1	15	3.5	16	24	8.0
106	101	6.5	32.0	41	19.2	40	34x1	25	8.0	25	36	15
107	105	8.0	34.0	45	22.7	45	38x1	32	10.0	30	40	18

Torque [Nm] are recommended values that may be influenced by the characteristics of the cable.

Tests have to be made to evaluate the exact values. To secure the cable clamp nut, we recommend the use of thread locking adhesive.

PANEL FRONT MOUNTED CABLE

DK

BODY STYLE

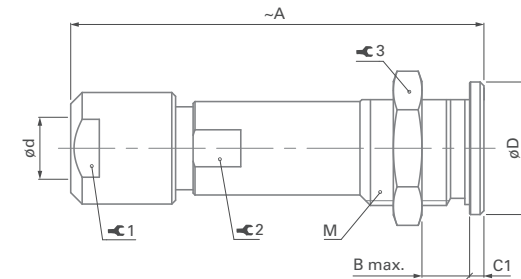

Series	A	B max.	C1	D	d max	M	⌘1	Torque1 [Nm]	⌘2	⌘3	Torque 3 [Nm]
102	35	9	1.5	11	4.7	9x0.5	7	0.6	-	11	1.3
103	44	10	1.5	14	6.7	12x1	10	1.0	9	14	2.5
1031	Please contact us for additional information										
104	50	11	2.0	19	8.7	15x1	12	2.0	12	17	4.0
105	60	16	2.0	22	10.7	18x1	15	3.5	14	22	6.0
106	80	21	3.0	37	19.2	32x1	25	8.0	25	TX00.106	15
107	105	17	4.0	40	22.7	35x1	32	10.0	30	TX00.107	16

RECEPTACLES

**PANEL FRONT
MOUNTED CABLE**

DKE - 102, 103 & 1031 SERIES

BODY STYLE

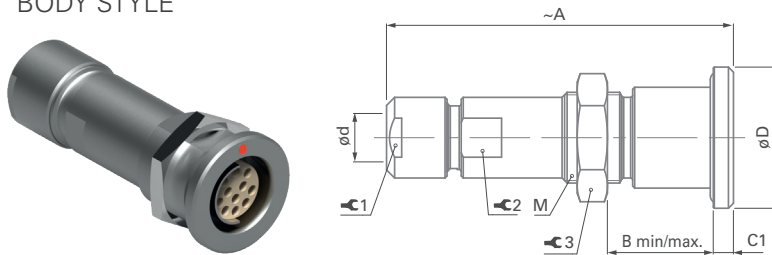

Series	A	B min/max.	C	C1	D	d max	M	⌘ ₁	Torque 1 [Nm]	⌘ ₂	⌘ ₃	Torque 3 [Nm]
102	35	9/12	-	2	14	4.3	9x0.5	7	0.6	7	11	1.3
103	45	9/14	-	3	17	6.2	14x1	10	1.0	10	17	3.0
1031	Please contact us for additional information											

DKE - 104, 105, 106 & 107 SERIES

BODY STYLE

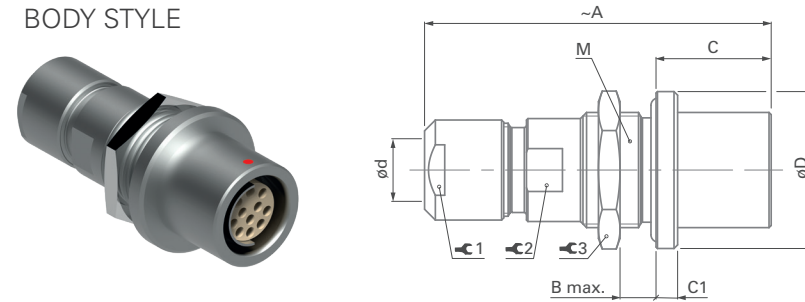

Series	A	B max.	C	C1	D	d max	M	⌘ ₁	Torque 1 [Nm]	⌘ ₂	⌘ ₃	Torque 3 [Nm]
104	50	8	16.0	3	22	8.7	16x1	12	2.0	13	19	4.5
105	61	9	19.0	4	27	10.7	20x1	15	3.5	16	25	6.5
106	85	9	25.5	7	37	19.2	30x1	25	8.0	25	TX00.106	14
107	110	21	25.0	5	45	22.7	35x1	32	10.0	30	TX00.107	16

ELECTRICAL & CONTACT CONFIGURATIONS

A/Z POLARITY

- For all body styles except WDE B2-24
- For WDE body style B2-24

CONTACT TYPES

- Solder contacts B2-25
- PCB contacts B2-25
- Crimp contacts, tooling B2-25

CONTACT CONFIGURATIONS

- 102 Series B2-27
- 103 & 1031 Series B2-28
- 104 Series B2-29
- 105 Series B2-31
- 106 Series B2-33
- 107 Series B2-34

A/Z POLARITY

To protect users from contact with dangerous voltages, most of our connectors exist in two versions:

STANDARD "A" POLARITY

The contacts of the receptacle are protected against accidental touch.

Recommended when voltage is present on the receptacle.

INVERTED "Z" POLARITY

The contacts of the plug are protected against accidental touch.

Recommended when voltage is present on the plug.

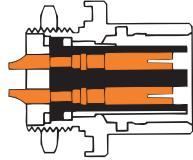
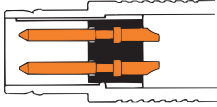
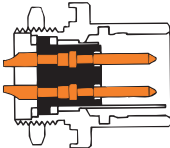
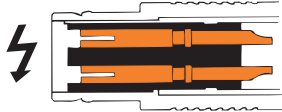
	Receptacle D	Plug S
Type "A" Standard Polarity		
Type "Z" Inverted Polarity		

IMPORTANT: AN "A" TYPE CONNECTOR CAN NEVER BE MATED WITH A "Z" TYPE CONNECTOR.

A plug "S" has the same housing in type "A" as in type "Z", but type "A" comes with unprotected contacts while type "Z" is equipped with touch-

protected contacts. In most cases these are female contacts which are recessed in the insulator.

BULKHEAD FEEDTHROUGH WDE

Type "AZ" is the standard version of the WDE. The flange side accepts an "A" type plug, and the threaded side accepts a "Z" type plug.

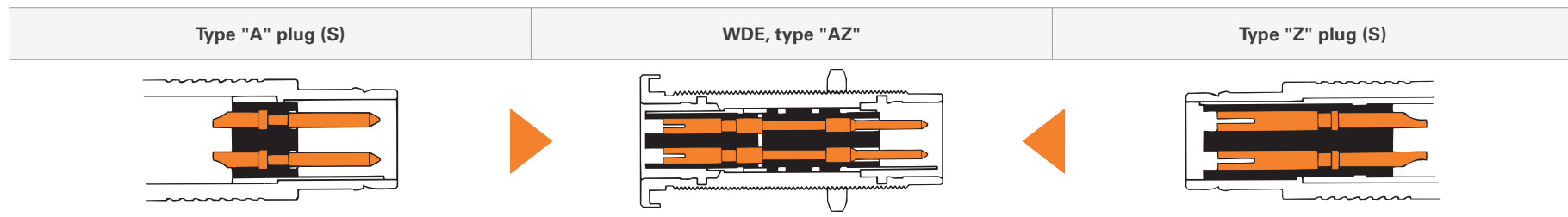

The "ZA" version of the WDE accepts a type "Z" plug at the flange side and accepts a type "A" plug at the threaded end.

CONTACT TYPES

Fischer Connectors' contacts are highly reliable and are guaranteed up to 10,000 mating cycles.

All standard brass and bronze contacts for use in the Core Series Brass are screw machined, and are gold plated over a nickel underplate.

Most connectors are available with solder, crimp or PCB contacts, and each type is optimized for a particular application.

SOLDER CONTACTS

Most versatile
Pre-installed contacts
Qualified assemblers required



- Can be produced with any type of contact block material and accept a wide range of wire sizes.
- Contacts are pre-installed in the insulator block, and the wires can be terminated with any appropriately sized soldering iron.
- May require operators who are qualified in specialized soldering techniques.

PCB CONTACTS

PCB or Flex circuit mount
Reduced pin diameter
Wave soldering



- Designed to be mounted directly onto a PCB or flex circuit; can be used in wave soldering operations for faster production assembly.
- Preferred for high rates of data transmission due to the low distance to the board that their integration allows. This helps reducing signal interferences.
- PCB pins are generally used on rear mounted panel connectors.

CRIMP CONTACTS

Selectively annealed area
Special tools required
Limited range of wire sizes



- Each contact has a selectively annealed area which is deformed during assembly by specialized tooling to assure proper termination of the wire to the contact.
- Commonly used for field termination or repair, as no soldering process is required.
- Not available for sealed or hermetic connectors.

TOOLING FOR CRIMP CONTACTS

Series	Polarity	Contact diameter (mm)									
		0.5		0.7		0.9		1.3		1.6	
		Part number		Part number		Part number		Part number		Part number	
		Contact	Positioner	Contact	Positioner	Contact	Positioner	Contact	Positioner	Contact	Positioner
102	Male	200.2113	TX00.300	200.2884	TX00.304	200.2890	TX00.307	-	-	-	-
	Female	200.2114	TX00.302	200.2885	TX00.305	200.2892	TX00.309	-	-	-	-
103	Male	200.2113	TX00.300	200.2884	TX00.304	200.2890	TX00.307	200.2402	TX00.311	-	-
	Female	200.2114	TX00.302	200.2885	TX00.305	200.2892	TX00.309	200.2214	TX00.312	-	-
1031	Male	200.2172	TX00.301	200.2884	TX00.304	200.2890	TX00.307	200.2402	TX00.311	-	-
	Female	200.2183	TX00.303	200.2885	TX00.305	200.2892	TX00.309	200.2214	TX00.312	-	-
104	Male	200.2172	TX00.301	200.2884	TX00.304	200.2890	TX00.307	200.2402	TX00.311	200.1653	TX00.313
	Female	200.2183	TX00.303	200.2885	TX00.305	200.2892	TX00.309	200.2214	TX00.312	200.1654	TX00.314
105	Male	-	-	200.2884	TX00.304	200.2891	TX00.308	200.2403	TX00.338	200.1653	TX00.313
	Female	-	-	200.2886	TX00.306	200.2893	TX00.310	200.2214	TX00.312	200.1654	TX00.314
Crimp tool part number		TX00.240		TX00.240		TX00.240		TX00.240		TX00.242	

See section Tooling, section B 6-21, for description of Crimping Tool and Positioner.
 Please refer to www.fischerconnectors.com/technical for detailed information and assembly instructions.

102 SERIES

● = Standard ○ = Option

Reference	Pin layout	Number of contacts	Contact types			Insulating material	Contact ø [mm]	Wire size ²⁾		Test voltage ⁵⁾ [kV] in mated position				Rated voltage ⁴⁾ r.m.s [V]	Current ³⁾ [A]
			Solder	Crimp ⁶⁾	PCB			Solder contacts ¹⁾⁸⁾	Crimp contacts	AC r.m.s		DC			
										Contact to body	Contact to contact	Contact to body	Contact to contact		
102 A Z 051		2	●	● ⁷⁾	●	PEEK	0.9	max ø0.79mm AWG21 [1] AWG22 [7/30]	max ø0.83mm min ø0.48mm AWG22-26	1.3	1.7	1.8	2.4	≤ 250	9.2
102 A Z 052		3	●		●	PEEK	0.9	max ø0.79mm AWG21 [1] AWG22 [7/30]	–	1.3	1.3	1.8	1.6	≤ 250	8.2
102 A Z 053		4	●	●	●	PEEK	0.7	max ø0.79mm AWG21 [1] AWG22 [7/30]	max ø0.62mm min ø0.38mm AWG24-28	1.2	1.2	1.7	1.8	≤ 200	5.5
102 A Z 054		5	●	●	●	PEEK	0.7	max ø0.79mm AWG21 [1] AWG22 [7/30]	max ø0.62mm min ø0.38mm AWG24-28	0.8	1.0	1.3	1.8	≤ 160	5.2
102 A Z 056		7	●	●	●	PEEK	0.5	max ø0.43mm AWG26 [1] AWG28 [19/40]	max ø0.43mm min ø0.20mm AWG28-32	0.8	1.0	1.3	1.8	≤ 160	4.0
102 A Z 059		9	●		●	PEEK	0.5	max ø0.43mm AWG26 [1] AWG28 [19/40]	–	0.8	1.1	1.2	1.8	≤ 160	3.1

¹⁾ Stranding values are in brackets.

²⁾ Testing may be required. For a given AWG, the diameter of some stranded conductor designs could exceptionally be larger than the hole diameter of the barrel.

³⁾ Current per contact at 40°C temperature rise measured on the basic curve according to IEC 60512-5-2-5b. For the max. operating current a reduction factor must be used and limitations due to the size of the wires and the permissible upper temperature limit of the materials employed must be taken into account. See page A-12 for details.

⁴⁾ Recommended operating voltage at sea level measured according to IEC 60664-1.

⁵⁾ Measured with S plug and D receptacle. Please contact us for ratings for WSO right-angle plugs and WDE bulkhead feedthroughs.

⁶⁾ Plug with crimp contacts must be used with unshielded clamps only. See page B2-41.

⁷⁾ Only available for A polarity plugs.

⁸⁾ Solder contact version of DBPLE/DBPLU with ground contact: Ground contact for wire size: max 0.79mm / AWG 21 [1] / AWG 22 [7/30].

103 & 1031 SERIES

● = Standard ○ = Option

Reference	Pin layout	Number of contacts	Contact types			Insulating material	Contact ϕ (mm)	Wire size ²⁾		Test voltage ⁵⁾ [kV] in mated position				Rated voltage ⁴⁾ r.m.s [V]	Current ³⁾ [A]
			Solder	Crimp	PCB			Solder contacts ¹⁾	Crimp contacts	AC r.m.s		DC			
										Contact to body	Contact to contact	Contact to body	Contact to contact		
103 $\begin{matrix} A \\ Z \end{matrix}$ 051		2	●	●	●	PEEK	1.3	max ϕ 1.18mm AWG17 [1] AWG18 [16/30]	max ϕ 1.18mm min ϕ 0.58mm AWG18-24	1.5	2.2	2.2	3.0	\leq 250	13
103 $\begin{matrix} A \\ Z \end{matrix}$ 052		3	●		●	PEEK	1.3	max ϕ 1.18mm AWG17 [1] AWG18 [16/30]	–	1.2	1.5	1.8	2.0	\leq 250	12
103 $\begin{matrix} A \\ Z \end{matrix}$ 053		4	●		●	PEEK	0.9	max ϕ 0.79mm AWG21 [1] AWG22 [7/30]	–	1.2	1.6	2.0	2.4	\leq 250	7.0
103 $\begin{matrix} A \\ Z \end{matrix}$ 054		5	●	●	●	PEEK	0.9	max ϕ 0.79mm AWG21 [1] AWG22 [7/30]	max ϕ 0.83mm min ϕ 0.48mm AWG22-26	1.1	1.4	1.9	2.2	\leq 250	6.8
103 $\begin{matrix} A \\ Z \end{matrix}$ 056		6	●	●	●	PEEK	0.7	max ϕ 0.79mm AWG21 [1] AWG22 [7/30]	max ϕ 0.62mm min ϕ 0.38mm AWG24-28	1.0	1.3	2.0	2.0	\leq 250	5.2
103 $\begin{matrix} A \\ Z \end{matrix}$ 057		7	●	●	●	PEEK	0.7	max ϕ 0.79mm AWG21 [1] AWG22 [7/30]	max ϕ 0.62mm min ϕ 0.38mm AWG24-28	1.0	1.3	2.0	2.0	\leq 250	5.0
103 $\begin{matrix} A \\ Z \end{matrix}$ 058		8	●		●	PEEK	0.7	max ϕ 0.79mm AWG21 [1] AWG22 [7/30]	max ϕ 0.62mm min ϕ 0.38mm AWG24-28	0.8	1.1	1.4	1.9	\leq 200	3.8
103 $\begin{matrix} A \\ Z \end{matrix}$ 062		12	●	●	●	PEEK	0.5	max ϕ 0.43mm AWG26 [1] AWG28 [19/40]	max ϕ 0.43mm min ϕ 0.20mm AWG28-32	0.9	1.2	1.5	1.8	\leq 200	2.0
1031 $\begin{matrix} A \\ Z \end{matrix}$ 010		10	●	●	●	PEEK	0.7	max ϕ 0.79mm AWG21 [1] AWG22 [7/30]	max ϕ 0.62mm min ϕ 0.38mm AWG24-28	1.4	1.5	2.0	2.2	\leq 250	4.5
1031 $\begin{matrix} A \\ Z \end{matrix}$ 012		12	●	●	●	PEEK	0.7	max ϕ 0.79mm AWG21 [1] AWG22 [7/30]	max ϕ 0.62mm min ϕ 0.38mm AWG24-28	1.4	1.5	2.0	2.2	\leq 250	4.2
1031 $\begin{matrix} A \\ Z \end{matrix}$ 019		19	●	●	●	PEEK	0.5	max ϕ 0.43mm AWG26 [1] AWG28 [19/40]	max ϕ 0.43mm min ϕ 0.20mm AWG28-32	1.2	0.9	2.0	1.5	\leq 250	2.5

¹⁾ Stranding values are in brackets.

²⁾ For a given AWG, the diameter of some stranded conductor designs could exceptionally be larger than the hole diameter of the barrel. Testing may be required.

³⁾ Current per contact at 40°C temperature rise measured on the basic curve according to IEC 60512-5-2-5b. For the max. operating current a reduction factor must be used and limitations due to the size of the wires and the permissible upper temperature limit of the materials employed must be taken into account. See page A-12 for details.

⁴⁾ Recommended operating voltage at sea level measured according to IEC 60664-1.

⁵⁾ Measured with S plug and D receptacle. Please contact us for rating for WSO right-angle plugs and WDE bulkhead feedthroughs.

104 SERIES

● = Standard ○ = Option

Reference	Pin layout	Number of contacts	Contact types			Insulating material	Contact ϕ [mm]	Wire size ²⁾		Test voltage ⁶⁾ [kV] in mated position				Rated voltage ⁴⁾ r.m.s [V]	Current ³⁾ [A]
			Solder	Crimp	PCB			Solder contacts ¹⁾	Crimp contacts	AC r.m.s		DC			
										Contact to body	Contact to contact	Contact to body	Contact to contact		
104 A Z 051		2	●		●	PEEK	1.6	max ϕ 1.86mm AWG13 [1] AWG14 [7/22]	–	1.8	2.2	2.8	3.2	\leq 500	20
104 A Z 040		3	○ ●		●	PEEK PBT	1.6	max ϕ 1.86mm AWG13 [1] AWG14 [7/22]	max ϕ 1.78mm min ϕ 1.17mm AWG14-18	1.6	2.0	2.6	3.0	\leq 500	18
104 A Z 037		4	●	●	●	PEEK	1.3	max ϕ 1.18mm AWG17 [1] AWG18 [16/30]	max ϕ 1.18mm min ϕ 0.58mm AWG18-24	1.8	2.2	2.5	3.0	\leq 500	12
104 A Z 087		2	●		●	PBT	2.3	max ϕ 2.48mm AWG11 [1] AWG12 [7/20]	–	1.5	1.6	2.2	2.5	\leq 400	28
		0.9					max ϕ 0.79mm AWG21 [1] AWG22 [7/30]	–	2.0			2.8			3.0
104 A Z 053		5	●		●	PEEK	1.3	max ϕ 1.18mm AWG17 [1] AWG18 [16/30]	–	1.4	1.7	2.4	2.7	\leq 320	11
104 A Z 065		6	●	●	●	PEEK	0.9	max ϕ 0.79mm AWG21 [1] AWG22 [7/30]	max ϕ 0.83mm min ϕ 0.48mm AWG22-26	1.7	2.0	2.4	2.6	\leq 400	6.5
104 A Z 054		7	●		●	PEEK	0.9	max ϕ 0.79mm AWG21 [1] AWG22 [7/30]	–	1.5	1.8 ⁵⁾	2.2	2.0 ⁵⁾	\leq 320	6.5
											2.1		2.8		

¹⁾ Stranding values are in brackets.

²⁾ For a given AWG, the diameter of some stranded conductor designs could exceptionally be larger than the hole diameter of the barrel. Testing may be required.

³⁾ Current per contact at 40°C temperature rise measured on the basic curve according to IEC 60512-5-2-5b. For the max. operating current a reduction factor must be used and limitations due to the size of the wires and the permissible upper temperature limit of the materials employed must be taken into account. See page A-12 for details.

⁴⁾ Recommended operating voltage at sea level measured according to IEC 60664-1.

⁵⁾ Test voltages between the contacts with the shortest distance.

⁶⁾ Measured with S plug and D receptacle. Please contact us for rating for WSO right-angle plugs and WDE bulkhead feedthroughs.

104 SERIES

● = Standard ○ = Option

Reference	Pin layout	Number of contacts	Contact types			Insulating material	Contact ϕ [mm]	Wire size ²⁾		Test voltage ⁶⁾ [kV] in mated position				Rated voltage ⁴⁾ r.m.s [V]	Current ³⁾ [A]
			Solder	Crimp	PCB			Solder contacts ¹⁾	Crimp contacts	AC r.m.s		DC			
										Contact to body	Contact to contact	Contact to body	Contact to contact		
104 A Z 066		8	●	●	●	PEEK	0.9	max ϕ 0.79mm AWG21 [1] AWG22 [7/30]	max ϕ 0.83mm min ϕ 0.48mm AWG22-26	1.5	1.5	2.5	2.5	\leq 320	6.2
104 A Z 055		1	●		●	PEEK	1.3	max ϕ 1.18mm AWG17 [1] AWG18 [16/30]	–	2.4	2.2	3.8	3.6	\leq 250	12
		8					0.9	max ϕ 0.79mm AWG21 [1] AWG22 [7/30]	–	1.4	1.5	2.0	2.4		6.0
104 A Z 056		11	●	●	●	PEEK	0.9	max ϕ 0.79mm AWG21 [1] AWG22 [7/30]	max ϕ 0.83mm min ϕ 0.48mm AWG22-26	1.4	1.5	2.1	2.2	\leq 250	5.8
104 A Z 086		16	●	●	●	PEEK	0.7	max ϕ 0.79mm AWG21 [1] AWG22 [7/30]	max ϕ 0.62mm min ϕ 0.38mm AWG24-28	1.0	1.5	1.6	2.2	\leq 200	4.0
104 A Z 092		19	●	●	●	PEEK	0.7	max ϕ 0.79mm AWG21 [1] AWG22 [7/30]	max ϕ 0.62mm min ϕ 0.38mm AWG24-28	0.8	1.2	1.2	1.8	\leq 200	3.5
104 A124 ⁵⁾		27	●	●	●	PEEK	0.5	–	max ϕ 0.43mm min ϕ 0.20mm AWG28-32	1.2	0.5	1.8	0.5	\leq 200	2.0

¹⁾ Stranding values are in brackets.

²⁾ For a given AWG, the diameter of some stranded conductor designs could exceptionally be larger than the hole diameter of the barrel. Testing may be required.

³⁾ Current per contact at 40°C temperature rise measured on the basic curve according to IEC 60512-5-2-5b. For the max. operating current a reduction factor must be used and limitations due to the size of the wires and the permissible upper temperature limit of the materials employed must be taken into account. See page A-12 for details.

⁴⁾ Recommended operating voltage at sea level measured according to IEC 60664-1.

⁵⁾ Solder and PCB contact types available only for DBPU and DBPLU receptacles. Crimp contact type available only for plugs.

⁶⁾ Measured with S plug and D receptacle. Please contact us for rating for WSO right-angle plugs and WDE bulkhead feedthroughs.

105 SERIES

● = Standard ○ = Option

Reference	Pin layout	Number of contacts	Contact types			Insulating material	Contact ø [mm]	Wire size ²⁾		Test voltage ⁶⁾ [kV] in mated position				Rated voltage ⁴⁾ r.m.s [V]	Current ³⁾ [A]
			Solder	Crimp	PCB			Solder contact ¹⁾	Crimp contacts	AC r.m.s		DC			
										Contact to body	Contact to contact	Contact to body	Contact to contact		
105 A Z 051		2	●			PEEK	2.0	max ø2.03mm AWG13 [1] AWG14 [7/22]	–	2.5	3.0	4.0	4.0	≤ 630	26
105 A Z 087		2	●			PEEK	3.0	max ø3.13mm AWG9 [1] AWG10 [105/30]	–	1.2	1.6	2.3	3.0	≤ 400	30
105 A Z 052		3	●			PEEK	2.0	max ø2.03mm AWG13 [1] AWG14 [7/22]	–	2.0	2.5	3.0	3.5	≤ 400	23
105 A Z 053		4	●			PEEK	2.0	max ø2.03mm AWG13 [1] AWG14 [7/22]	–	1.8	1.8	2.6	2.6	≤ 320	20
105 A Z 054 ⁵⁾		1	●			PEEK	2.0	max ø2.03mm AWG13 [1] AWG14 [7/22]	–	3.0	2.0	4.0	3.0	≤ 320	25
		6					1.3	max ø1.18mm AWG17 [1] AWG18 [16/30]	–	1.8	1.5	2.5	2.0		7.0
105 A Z 067		8	●			PEEK	1.3	max ø1.18mm AWG17 [1] AWG18 [16/30]	–	1.7	2.0	2.5	2.8	≤ 320	10
105 A 124		2	●			PEEK	2.3	max ø2.48mm AWG11 [1] AWG12 [7/20]	–	1.2	2.2	1.8	3.2	≤ 250	18.5
		6					1.3	max ø1.18mm AWG17 [1] AWG18 [16/30]	–	1.2	1.2	1.8	1.8		7.5
105 A Z 101 ⁵⁾		1	●		●	PEEK	2.0	max ø2.03mm AWG13 [1] AWG14 [7/22]	–	3.0	2.0	4.0	3.0	≤ 320	25
		8					1.3	max ø1.18mm AWG17 [1] AWG18 [16/30]	–	1.8	1.5	2.5	2.0		5.0

¹⁾ Stranding values are in brackets.

²⁾ For a given AWG, the diameter of some stranded conductor designs could exceptionally be larger than the hole diameter of the barrel. Testing may be required.

³⁾ Current per contact at 40°C temperature rise measured on the basic curve according to IEC 60512-5-2-5b. For the max. operating current a reduction factor must be used and limitations due to the size of the wires and the permissible upper temperature limit of the materials employed must be taken into account. See page A-12 for details.

⁴⁾ Recommended operating voltage at sea level measured according to IEC 60664-1.

⁵⁾ Contact dia. 2.0 is positioned to make contact first and break last.

⁶⁾ Measured with S plug and D receptacle. Please contact us for rating for WSO right-angle plugs and WDE bulkhead feedthroughs.

All dimensions and images shown are in millimeters and are for reference only.

105 SERIES

● = Standard ○ = Option

Reference	Pin layout	Number of contacts		Contact types			Insulating material	Contact ø [mm]	Wire size ²⁾		Test voltage ⁸⁾ [kV] in mated position				Rated voltage ⁴⁾ r.m.s [V]	Current ³⁾ [A]
				Solder	Crimp	PCB			Solder contacts ¹⁾	Crimp contacts	AC r.m.s		DC			
											Contact to body	Contact to contact	Contact to body	Contact to contact		
105 A Z 062		10		●	●	●	PEEK	1.3	max ø1.18mm AWG17 [1] AWG18 [16/30]	max ø1.18mm min ø0.58mm AWG18-24	1.7	2.0	2.5	2.7	≤ 320	9.0
105 A Z 069		12		●		●	PEEK	1.3	max ø1.18mm AWG17 [1] AWG18 [16/30]	-	1.4	1.5	1.8	2.0	≤ 250	8.0
105 A Z 104 ⁵⁾		3	13	●		●	PEEK	1.3	max ø1.18mm AWG17 [1] AWG18 [16/30]	-	2.5	1.5	3.8	2.2	≤ 320	14
		10						0.7								
105 A 127 ⁷⁾		3	13		●		PEEK	1.3	-	max ø1.18mm min ø0.58mm AWG18-24	3.0	2.8	4.8	3.9	≤ 320	14
		10						0.7	-	max ø0.62mm min ø0.38mm AWG24-28	3.1	1.1	4.7	1.9		1.0
105 A Z 058		15		●	●	●	PEEK	0.9	max ø0.79mm AWG21 [1] AWG22 [7/30]	max ø0.83mm min ø0.48mm AWG22-26	1.4	1.6	1.8	2.2	≤ 250	5.3
105 A Z 110 ⁶⁾		4	16	●		●	PEEK	1.6	max ø1.86mm AWG13 [1] AWG14 [7/22]	-	1.6	1.3	2.8	2.1	≤ 250	14
		12						0.7	max ø0.79mm AWG21 [1] AWG22 [7/30]	-	1.0	1.2	1.5	2.0		1.0
105 A Z 038		18		●	●	●	PEEK	0.9	max ø0.79mm AWG21 [1] AWG22 [7/30]	max ø0.83mm min ø0.48mm AWG22-26	1.4	1.6	1.8	2.2	≤ 200	4.5
105 A Z 093		24		●		●	PBT	0.7	max ø0.79mm AWG21 [1] AWG22 [7/30]	-	1.2	1.5	1.5	2.0	≤ 250	3.5
105 A Z 102		27		●	●	●	PEEK	0.7	max ø0.79mm AWG21 [1] AWG22 [7/30]	max ø0.62mm min ø0.38mm AWG24-28	1.2	1.5	1.5	2.0	≤ 250	3.0

¹⁾ Stranding values are in brackets.

²⁾ For a given AWG, the diameter of some stranded conductor designs could exceptionally be larger than the hole diameter of the barrel. Testing may be required.

³⁾ Current per contact at 40°C temperature rise measured on the basic curve according to IEC 60512-5-2-5b. For the max. operating current a reduction factor must be used and limitations due to the size of the wires and the permissible upper temperature limit of the materials employed must be taken into account. See page A-12 for details.

⁴⁾ Recommended operating voltage at sea level measured according to IEC 60664-1.

⁵⁾ Contacts dia. 1.3 are positioned to make contact first and break last.

⁶⁾ Contacts dia. 1.6 are positioned to make contact first and break last.

⁷⁾ Inverted polarity: female contacts on plug/male contact on receptacle

⁸⁾ Measured with S plug and D receptacle. Please contact us for rating for WSO right-angle plugs and WDE bulkhead feedthroughs.

106 SERIES

● = Standard ○ = Option

Reference	Pin layout	Number of contacts	Contact types			Insulating material	Contact ø [mm]	Wire size ²⁾		Test voltage ⁷⁾ [kV] in mated position				Rated voltage ⁴⁾ r.m.s [V]	Current ³⁾ [A]
			Solder	Crimp	PCB			Male solder contacts ¹⁾	Female solder contacts ¹⁾	AC r.m.s		DC			
										Contact to body	Contact to contact	Contact to body	Contact to contact		
106 ^A / _Z 003 ⁵⁾		3	● ○			PTFE PEEK	2.3	max ø2.13mm AWG12 [1] AWG14 [7/22]	max ø2.28mm AWG12 [1] AWG14 [105/34]	3.5	5.0	6.0	6.5	≤ 1000	26
106 ^A / _Z 007 ⁵⁾⁶⁾		7	● ○			PTFE PEEK	2.0	max ø2.08mm AWG12 [1] AWG14 [7/22]	max ø2.03mm AWG13 [1] AWG14 [7/22]	2.5	3.0	4.5	4.5	≤ 800	20
106 ^A / _Z 019		8	● ○			PTFE PEEK	2.0	max ø2.08mm AWG12 [1] AWG14 [7/22]	max ø2.03mm AWG13 [1] AWG14 [7/22]	2.2	2.2	4.0	3.0	≤ 630	19
106 ^A / _Z 015		12	● ○			PTFE PEEK	2.0	max ø2.08mm AWG12 [1] AWG14 [7/22]	max ø2.03mm AWG13 [1] AWG14 [7/22]	1.8	2.2	2.5	3.0	≤ 500	16
106 ^A / _Z 018		17	● ○			PTFE PEEK	1.3	max ø1.18mm AWG17 [1] AWG18 [16/30]	max ø1.23mm AWG17 [1] AWG18 [16/30]	1.8	2.2	2.5	3.0	≤ 500	8.0
106 ^A / _Z 017		24	● ○			PTFE PEEK	1.3	max ø1.18mm AWG17 [1] AWG18 [16/30]	max ø1.18mm AWG17 [1] AWG18 [16/30]	1.8	1.5	2.5	2.1	≤ 400	7.0

¹⁾ Stranding values are in brackets.

²⁾ For a given AWG, the diameter of some stranded conductor designs could exceptionally be larger than the hole diameter of the barrel. Testing may be required.

³⁾ Current per contact at 40°C temperature rise measured on the basic curve according to IEC 60512-5-2-5b. For the max. operating current a reduction factor must be used and limitations due to the size of the wires and the permissible upper temperature limit of the materials employed must be taken into account. See page A-12 for details.

⁴⁾ Recommended operating voltage at sea level measured according to IEC 60664-1.

⁵⁾ The contact solder cups are specially insulated.

⁶⁾ Contact Number 1 is positioned to make contact first and break last.

⁷⁾ Measured with S plug and D receptacle. Please contact us for rating for WDE bulkhead feedthroughs.

107 SERIES

● = Standard ○ = Option

Reference	Pin layout	Number of contacts		Contact types			Insulating material	Contact ϕ [mm]	Wire size ²⁾		Test voltage ⁵⁾ [kV] in mated position				Rated voltage ⁴⁾ r.m.s [V]	Current ³⁾ [A]
				Solder	Crimp	PCB			Male solder contacts ¹⁾	Female solder contacts ¹⁾	AC r.m.s		DC			
											Contact to body	Contact to contact	Contact to body	Contact to contact		
107 A Z 013		4		●			PTFE	2.3	max ϕ 2.93mm AWG9 [1] AWG10 [37/26]	max ϕ 2.28mm AWG12 [1] AWG14 [105/34]	3.6	4.3	5.0	5.6	\leq 1000	26
107 A Z 018		6		● ○			PTFE PEEK	2.3	max ϕ 2.93mm AWG9 [1] AWG10 [37/26]	max ϕ 2.28mm AWG12 [1] AWG14 [105/34]	3.4	3.4	4.3	4.3	\leq 800	25
107 A Z 015		19		● ○			PTFE PEEK	2.0	max ϕ 2.08mm AWG12 [1] AWG14 [7/22]	max ϕ 2.03mm AWG13 [1] AWG14 [7/22]	2.0	2.5	2.5	3.2	\leq 500	13
107 A Z 051		27		● ○			PTFE PEEK	1.3	max ϕ 1.18mm AWG17 [1] AWG18 [16/30]	max ϕ 1.18mm AWG17 [1] AWG18 [16/30]	2.0	2.0	3.0	3.2	\leq 400	7.5
107 A Z 052		40		● ○			PTFE PEEK	1.3	max ϕ 1.18mm AWG17 [1] AWG18 [16/30]	max ϕ 1.18mm AWG17 [1] AWG18 [16/30]	1.8	1.5	2.5	2.0	\leq 320	6.5
107 A Z 023		8		●			PTFE	1.3	max ϕ 1.18mm AWG17 [1] AWG18 [16/30]	max ϕ 1.18mm AWG17 [1] AWG18 [16/30]	2.0	1.8	2.8	2.5	\leq 400	7.0
		47		○			PEEK	0.9	max ϕ 0.79mm AWG21 [1] AWG22 [7/30]	max ϕ 0.88mm AWG20 [1] AWG22 [19/34]	1.7	1.5	2.5	2.1		3.0

¹⁾ Stranding values are in brackets.

²⁾ For a given AWG, the diameter of some stranded conductor designs could exceptionally be larger than the hole diameter of the barrel. Testing may be required.

³⁾ Current per contact at 40°C temperature rise measured on the basic curve according to IEC 60512-5-2-5b. For the max. operating current a reduction factor must be used and limitations due to the size of the wires and the permissible upper temperature limit of the materials employed must be taken into account. See page A-12 for details.

⁴⁾ Recommended operating voltage at sea level measured according to IEC 60664-1.

⁵⁾ Measured with S plug and D receptacle. Please contact us for rating for WDE bulkhead feedthroughs.

OPTIONS

- Housing colors B2-36
- Cable bend reliefs and clamp nut types B2-36

OPTIONS **PART NUMBERING**

- Cable bend relief part numbering B2-38

HOUSING COLORS & CABLE BEND RELIEFS

CONNECTOR HOUSING COLORS

All the body styles of our Core Series Brass Product Line are available in two colors:

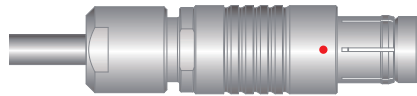

- Natural chrome connector housing with red guide mark.

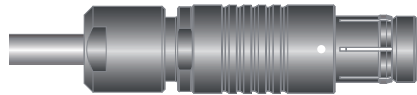

- Non reflective black chrome housing with white guide mark.

Guide mark is standard for Multipole Low and High Voltage, Mixed Multipole and Mixed Coax connectors.

Color-coding is achieved by using accessories:

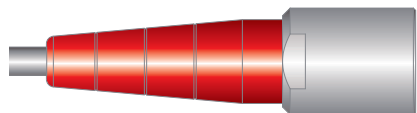

- Cable bend reliefs for cable connectors.



- Washers for panel receptacles.

CABLE BEND RELIEFS & CLAMP NUT TYPES

A cable bend relief is a useful accessory for connectors mounted with cable clamp sets (S/SC; SOV; SA; SV; WSO; K/KE; DK; DKE; DBKE).

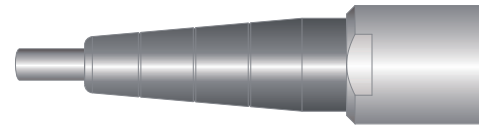



It helps to:

- Reduce bending stress on the cable and inner wires, enhancing durability
- Color-code your connectors for easy identification.



Cable bend reliefs require special clamp nuts, thus are linked with your selection of options.

HOUSING COLORS & CABLE BEND RELIEFS

1	Housing color Which housing color do you need?	NATURAL CHROME with red guide mark					BLACK CHROME with white guide mark					
2	Contact block material Which contact block material do you need?	PTFE	PBT		PEEK		PTFE	PBT		PEEK		
3	Contact type Which contact type do you need?	Solder	Solder	Crimp ¹⁾	Solder	Crimp ¹⁾	Solder	Solder	Crimp ¹⁾	Solder	Crimp ¹⁾	
4	Keying code Which keying code do you need?	Code 1 	-60	-80	-100	-130	-150	-70	-90	-110	-140	-160
		Code 2 	-2060	-2080	-2100	-230	-250	-2070	-2090	-2100	-240	-260
		Code 3 	-3060	-3080	-3100	-330	-350	-3070	-3090	-3100	-340	-360

¹⁾ Crimp contacts are not an option for sealed or hermetic connectors.

CONTACT TYPE FOR PANEL MOUNTED CONNECTORS

Applicable for	Last digit	Description
Front mounted: D-DEU/E-DB-DBEU/E- DG-SF-SFU/E	0	Standard: solder contacts
	9	With PCB (Printed Circuit Board) contacts instead of solder contacts
Rear mounted: DBP-DBPU/E-DBPLU/E -DGP-SFPU/E	0	Standard: PCB (Printed Circuit Board) contacts
	9	With solder contacts instead of PCB (Printed Circuit Board) contacts

Options are available on request, please contact us.







DESIGN AND ACCESSORIES

Applicable for	Extensions	Description
Receptacles	N	Nickel plated body with bright finish
	E	EPDM interface O-ring
	G	Ground tag if solder contact or ground pin if PCB contact
	B	Black nut
	D	Decorative slotted nut
	F	Decorative nut (with 2 flats)

CABLE BEND RELIEFS PART NUMBERING

CABLE BEND RELIEF

Do you need a cable bend relief, and if yes which color ?

Applicable for	Last digit	Description
Cable mounted plugs & receptacles using cable clamp sets except SS/SSC-KS/KSE	0	Clamp nut without bend relief
	1	Clamp nut with white bend relief 
	2	Clamp nut with black bend relief 
	3	Clamp nut with green bend relief 
	4	Clamp nut with blue bend relief 
	5	Clamp nut with yellow bend relief 
	6	Clamp nut with red bend relief 
	7	Clamp nut with grey bend relief 

EXAMPLES

PLUGS

S 102 A056-130+

Natural chrome housing color with PEEK contact block, solder contacts, keying code 1, clamp nut without bend relief and without cable clamp set (To be ordered separately)

S 102 A056-232+

Natural chrome housing color with PEEK contact block, solder contacts, keying code 2, clamp nut with black bend relief, without cable clamp set

SS 102 A056-260

Black chrome housing color with PEEK contact block, crimp contacts, keying code 2

RECEPTACLES

D 102 A056-130

Natural chrome housing color with PEEK contact block, solder contacts, keying code 1

D 102 A056-260

Black chrome housing color with PEEK contact block, crimp contacts, keying code 2

DBPU 102 A056-130G

Natural chrome housing color with PEEK contact block, PCB contacts, keying code 1 and ground pin

DBPU 102 A056-130NBE

Nickel plated body with PEEK contact block, PCB contacts, keying code 1, with black nut and EPDM interface O-ring

INTRODUCTION

- Range overview: S, U & E types B 2-40
- Part numbering B 2-40

DIMENSIONS

S/SC; SOV; SA; SV; K/KE; DK; DKE & DKBE; BODY STYLES

- 102 Series B 2-41
- 103 Series B 2-42
- 1031 Series B 2-43
- 104 Series B 2-44
- 105 Series B 2-45
- 106 Series B 2-46
- 107 Series B 2-47

WSO BODY STYLE

- 102, 103, 1031, 104 & 105 Series B 2-48

INTRODUCTION

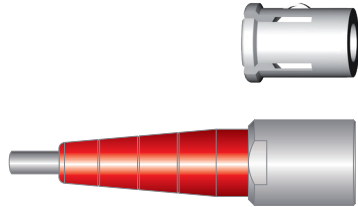

To guarantee excellent cable retention and strain relief, Fischer Connectors provides robust and high quality cable clamp sets:

- Collet style clamp system retaining cable over large jacket surface area.
- Protection of small diameters and delicate conductors.
- Can be combined with cable bend reliefs for optimal performance.

Cable clamp sets are suitable for all cable mounted connectors, except SS/SSC and KS/KSE.

RANGE OVERVIEW: S, U & E CABLE CLAMP SETS

Fischer Connectors offers three types of cable clamps sets. The table below will help you select the one corresponding to your needs.

Cable clamp set	Do you need the interface between the cable and the connector to be sealed?	
	Unsealed	Sealed
S - Shielded	●	
U - Unshielded	●	
E - Environmental		●

For 106 and 107 connector series, only S and E cable clamp sets are available.

PART NUMBERING

Below cable clamp sets should be ordered separately	
Multipole low voltage	Triax
S 102 A056-130+	
Examples connector ordering line	
S 102 A056-130+	
Clamp set ordering line	
E3 102.5/2.0	

See following pages for cable clamp sets set selection.

Do you need the connector to be terminated to the cable shield?	
Unshielded	Shielded
	●
●	
●	●

Below cable clamp sets are included with connector	
Coax low voltage	Coax high voltage
Shielded (S) or Environmental (E) cable clamp set diameter should be added to the connector part number separated by ϕ .	
Examples for S - Shielded clamp sets	
K 103 A002-600 ϕ6.2	
For E - Environmental clamp sets	
KE 103 A002-600 ϕ6.2	

See following pages for S or E cable clamp sets set selection.

102 SERIES

S SHIELDED

Shielded cable clamp with sleeve and clamp.



Cable dia. range	Collet Ø	Cable clamp set ¹⁾
1.5 - 2.1	2.1	E32 102.1/2.1 + A
2.1 - 2.6	2.6	E32 102.1/2.6 + A
2.6 - 3.1	3.1	E32 102.1/3.1 + A
3.1 - 3.6	3.6	E32 102.1/3.6 + A
3.6 - 4.1	4.1	E32 102.1/4.1 + A
4.1 - 4.3	4.3	E32 102.1/4.3 + A
4.3 - 4.7	4.7	E3 102.248 + A

U UNSHIELDED

Unshielded, one-piece cable clamp.



Cable dia. range	Collet Ø	Cable clamp set ¹⁾
1.4 - 2.0	2.0	E3 102.5/2.0
2.0 - 2.7	2.7	E3 102.5/2.7
2.7 - 3.5	3.5	E3 102.5/3.5
3.5 - 4.2	4.2	E3 102.5/4.2
4.2 - 4.7	4.7	E3 102.5/4.7

E ENVIRONMENTAL

Environmentally sealed clamp for use with shielded or unshielded cables.

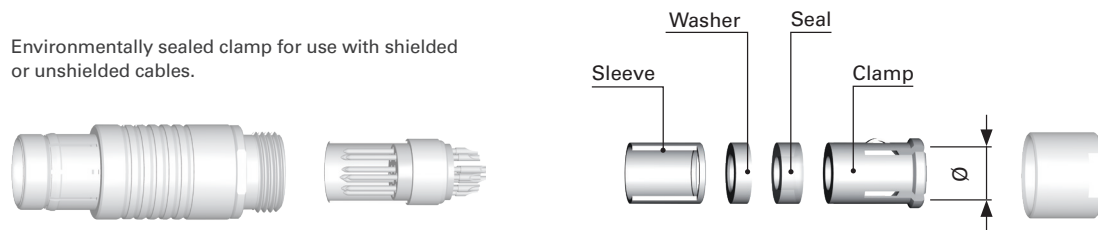

Cable dia. range	Collet Ø	Cable clamp set ¹⁾
1.5 - 2.1	2.1	E31 102.2/2.1 + B
2.1 - 2.6	2.6	E31 102.2/2.6 + B
2.6 - 3.1	3.1	E31 102.2/3.1 + B
3.1 - 3.6	3.6	E31 102.2/3.6 + B
3.6 - 4.1	4.1	E31 102.2/4.1 + B
4.1 - 4.3	4.3	E31 102.2/4.3 + B

¹⁾ For ordering information see page B2-40.

103 SERIES

S SHIELDED

Shielded cable clamp with with sleeve, washer and clamp.

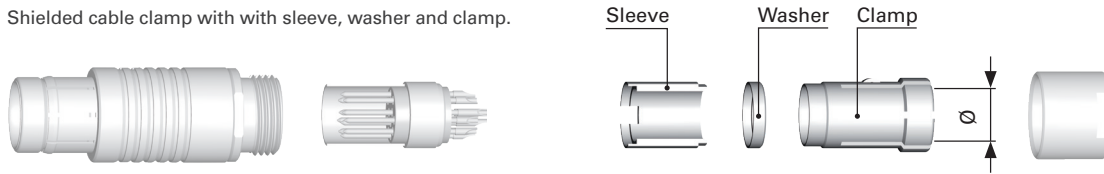

Cable dia. range	Collet Ø	Cable clamp set ¹⁾ PEEK or PBT insulator
1.7 - 2.2	2.2	E31 103.1/2.2 + B
2.2 - 2.7	2.7	E31 103.1/2.7 + B
2.7 - 3.2	3.2	E31 103.1/3.2 + B
3.2 - 3.7	3.7	E31 103.1/3.7 + B
3.7 - 4.2	4.2	E31 103.1/4.2 + B
4.2 - 4.7	4.7	E31 103.1/4.7 + B
4.7 - 5.2	5.2	E31 103.1/5.2 + B
5.2 - 5.7	5.7	E31 103.1/5.7 + B
5.7 - 6.2	6.2	E31 103.1/6.2 + B
6.2 - 6.7	6.7	E31 103.1/6.7 + B

U UNSHIELDED

Unshielded, one-piece cable clamp.

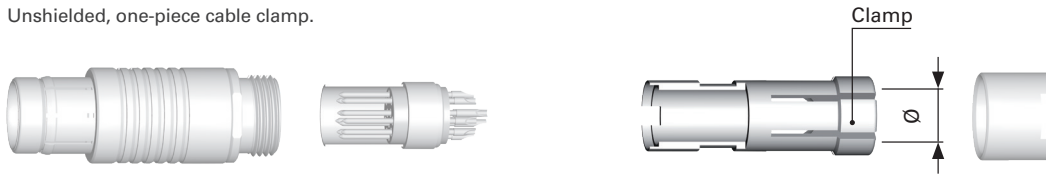

Cable dia. range	Collet Ø	Cable clamp set ¹⁾ PEEK or PBT insulator
2.2 - 3.2	3.2	E3 103.6/3.2
3.2 - 4.2	4.2	E3 103.6/4.2
4.2 - 4.7	4.7	E3 103.6/4.7
4.7 - 5.2	5.2	E3 103.6/5.2
5.2 - 5.7	5.7	E3 103.6/5.7
5.7 - 6.2	6.2	E3 103.6/6.2
6.2 - 6.7	6.7	E3 103.6/6.7

E ENVIRONMENTAL

Environmentally sealed clamp for use with shielded or unshielded cables.

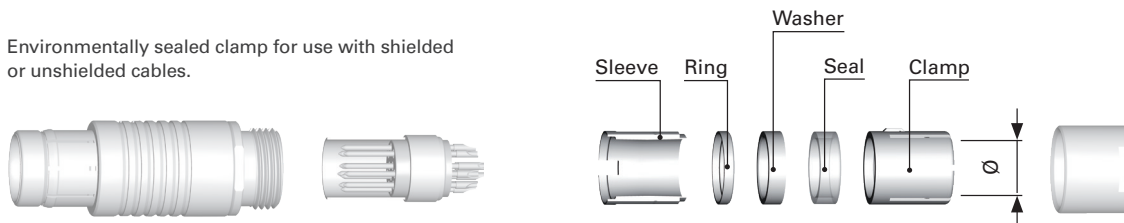

Cable dia. range	Collet Ø	Cable clamp set ¹⁾ PEEK or PBT insulator
1.7 - 2.2	2.2	E31 103.2/2.2 + B
2.2 - 2.7	2.7	E31 103.2/2.7 + B
2.7 - 3.2	3.2	E31 103.2/3.2 + B
3.2 - 3.7	3.7	E31 103.2/3.7 + B
3.7 - 4.2	4.2	E31 103.2/4.2 + B
4.2 - 4.7	4.7	E31 103.2/4.7 + B
4.7 - 5.2	5.2	E31 103.2/5.2 + B
5.2 - 5.7	5.7	E31 103.2/5.7 + B
5.7 - 6.2	6.2	E31 103.2/6.2 + B

¹⁾ For ordering information see page B 2-40.

1031 SERIES

S SHIELDED

Shielded cable clamp with with sleeve, washer and clamp.

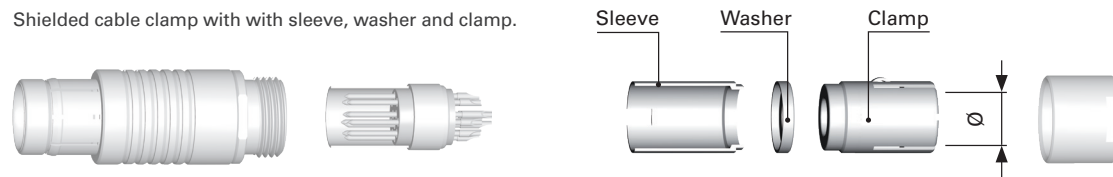

Cable \varnothing range	Collet \varnothing	Cable clamp set ¹⁾
2.2 - 2.7	2.7	E3 1031.1/2.7
2.7 - 3.2	3.2	E3 1031.1/3.2
3.2 - 3.7	3.7	E3 1031.1/3.7
3.7 - 4.2	4.2	E3 1031.1/4.2
4.2 - 4.7	4.7	E3 1031.1/4.7
4.7 - 5.2	5.2	E3 1031.1/5.2
5.2 - 5.7	5.7	E3 1031.1/5.7
5.7 - 6.2	6.2	E3 1031.1/6.2
6.2 - 6.7	6.7	E3 1031.1/6.7
6.7 - 7.2	7.2	E3 1031.1/7.2

U UNSHIELDED

Unshielded, one-piece cable clamp.



Cable \varnothing range	Collet \varnothing	Cable clamp set ¹⁾
2.2 - 2.7	2.7	E3 1031.6/2.7
2.7 - 3.2	3.2	E3 1031.6/3.2
3.2 - 3.7	3.7	E3 1031.6/3.7
3.7 - 4.2	4.2	E3 1031.6/4.2
4.2 - 4.7	4.7	E3 1031.6/4.7
4.7 - 5.2	5.2	E3 1031.6/5.2
5.2 - 5.7	5.7	E3 1031.6/5.7
5.7 - 6.2	6.2	E3 1031.6/6.2
6.2 - 6.7	6.7	E3 1031.6/6.7
6.7 - 7.2	7.2	E3 1031.6/7.2

E ENVIRONMENTAL

Environmentally sealed clamp for use with shielded or unshielded cables.

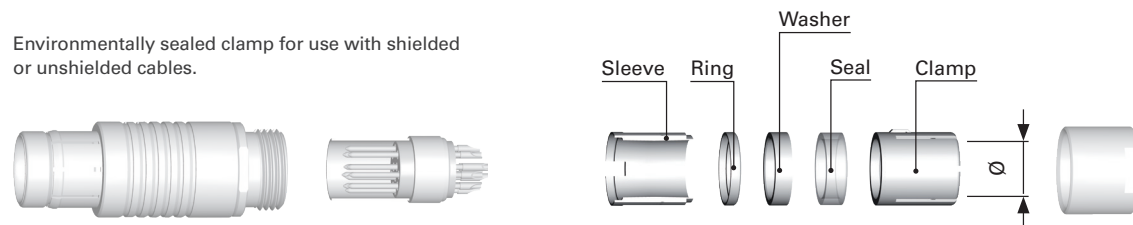

Cable \varnothing range	Collet \varnothing	Cable clamp set ¹⁾
2.2 - 2.7	2.7	E3 1031.2/2.7
2.7 - 3.2	3.2	E3 1031.2/3.2
3.2 - 3.7	3.7	E3 1031.2/3.7
3.7 - 4.2	4.2	E3 1031.2/4.2
4.2 - 4.7	4.7	E3 1031.2/4.7
4.7 - 5.2	5.2	E3 1031.2/5.2
5.2 - 5.7	5.7	E3 1031.2/5.7
5.7 - 6.2	6.2	E3 1031.2/6.2
6.2 - 6.7	6.7	E3 1031.2/6.7

¹⁾ For ordering information see page B2-40.

All dimensions and images shown are in millimeters and are for reference only.

104 SERIES

S SHIELDED

Shielded cable clamp with with sleeve, spacer and clamp.

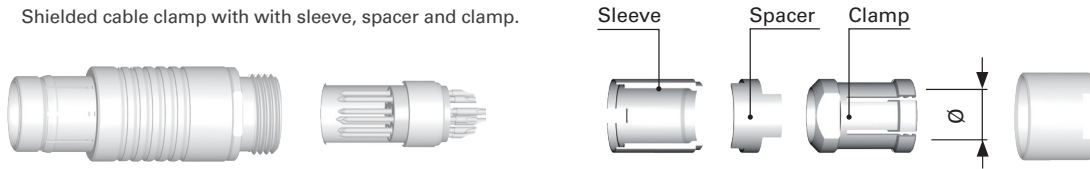

Cable Ø range	Collet Ø	Cable clamp set ¹⁾ PEEK or PBT insulator	
		Plug	Receptacle
2.9 - 4.0	4.0	E3 104.3/4.0 + B	E3 104.4/4.0 + C
4.0 - 4.7	4.7	E3 104.3/4.7 + B	E3 104.4/4.7 + C
4.7 - 5.7	5.7	E3 104.3/5.7 + B	E3 104.4/5.7 + C
5.7 - 6.7	6.7	E3 104.3/6.7 + B	E3 104.4/6.7 + C
6.7 - 7.7	7.7	E3 104.3/7.7 + B	E3 104.4/7.7 + C
7.7 - 8.7	8.7	E3 104.3/8.7 + B	E3 104.4/8.7 + C
8.7 - 9.1	9.1	E3 104.3/9.1 + B	E3 104.4/9.1 + C

U UNSHIELDED

Unshielded, one-piece cable clamp.

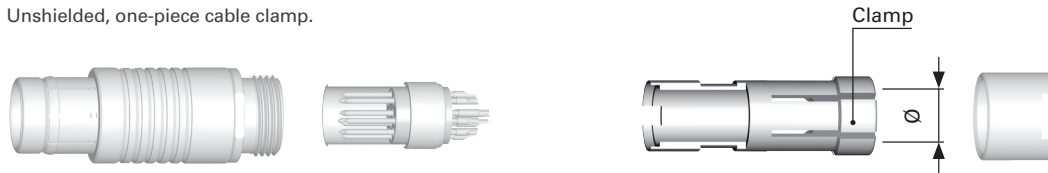

Cable Ø range	Collet Ø	Cable clamp set ¹⁾ PEEK or PBT insulator
4.2 - 4.7	4.7	E3 104.6/4.7
4.7 - 5.7	5.7	E3 104.6/5.7
5.7 - 6.7	6.7	E3 104.6/6.7
6.7 - 7.7	7.7	E3 104.6/7.7
7.7 - 8.2	8.2	E3 104.6/8.2
8.2 - 8.7	8.7	E3 104.6/8.7

E ENVIRONMENTAL

Environmentally sealed clamp for use with shielded or unshielded cables.

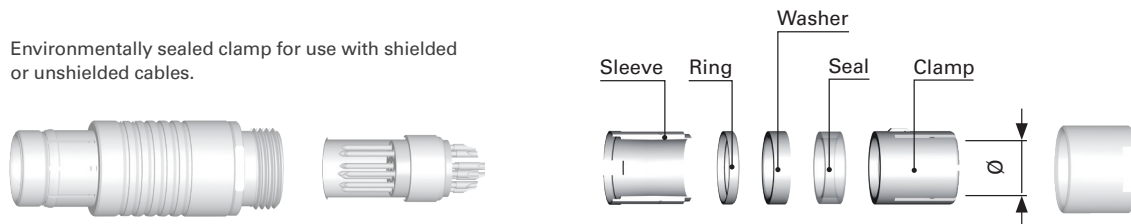

Cable Ø range	Collet Ø	Cable clamp set ¹⁾ PEEK or PBT insulator	
		Plug	Receptacle
2.9 - 4.0	4.0	E3 104.2/4.0 + B	E3 104.2/4.0 + C
4.0 - 4.7	4.7	E3 104.2/4.7 + B	E3 104.2/4.7 + C
4.7 - 5.7	5.7	E3 104.2/5.7 + B	E3 104.2/5.7 + C
5.7 - 6.7	6.7	E3 104.2/6.7 + B	E3 104.2/6.7 + C
6.7 - 7.7	7.7	E3 104.2/7.7 + B	E3 104.2/7.7 + C
7.7 - 8.7	8.7	E3 104.2/8.7 + B	E3 104.2/8.7 + C

¹⁾ For ordering information see page B 2-40.

105 SERIES

S SHIELDED

Shielded cable clamp with sleeve, spacer and clamp.



Cable \varnothing range	Collet \varnothing	Cable clamp set ¹⁾ PEEK or PBT insulator
3.2 - 4.2	4.2	E3 105.1/4.2 + B
4.2 - 5.2	5.2	E3 105.1/5.2 + B
5.2 - 6.2	6.2	E3 105.1/6.2 + B
6.2 - 7.2	7.2	E3 105.1/7.2 + B
7.2 - 8.2	8.2	E3 105.1/8.2 + B
8.2 - 9.2	9.2	E3 105.1/9.2 + B
9.2 - 10.0	10.0	E3 105.1/10.0 + B
10.0 - 10.7	10.7	E3 105.1/10.7 + B

U UNSHIELDED

Unshielded, one-piece cable clamp.



Cable \varnothing range	Collet \varnothing	Cable clamp set ¹⁾ PEEK or PBT insulator
2.5 - 3.5	3.5	E3 105.6/3.5
3.5 - 4.5	4.5	E3 105.6/4.5
4.5 - 5.5	5.5	E3 105.6/5.5
5.5 - 6.5	6.5	E3 105.6/6.5
6.5 - 7.5	7.5	E3 105.6/7.5
7.5 - 8.5	8.5	E3 105.6/8.5
8.5 - 9.5	9.5	E3 105.6/9.5
9.5 - 10.5	10.5	E3 105.6/10.5

E ENVIRONMENTAL

Environmentally sealed clamp for use with shielded or unshielded cables.



Cable \varnothing range	Collet \varnothing	Cable clamp set ¹⁾ PEEK or PBT insulator
3.2 - 4.2	4.2	E31 105.2/4.2 + B
4.2 - 5.2	5.2	E31 105.2/5.2 + B
5.2 - 6.2	6.2	E31 105.2/6.2 + B
6.2 - 7.2	7.2	E31 105.2/7.2 + B
7.2 - 8.2	8.2	E31 105.2/8.2 + B
8.2 - 9.2	9.2	E31 105.2/9.2 + B
9.2 - 10.0	10.0	E31 105.2/10.0 + B
10.0 - 10.7	10.7	E31 105.2/10.7 + B

¹⁾ For ordering information see page B2-40.

106 SERIES

S
SHIELDED

Shielded cable clamp with sleeve, spacer and clamp.

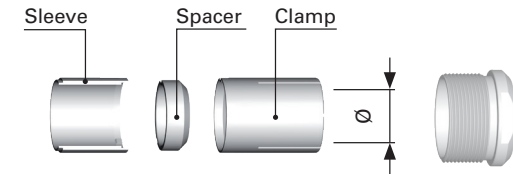

Cable Ø range	Collet Ø	Cable clamp set ¹⁾ PTFE insulator	
		Standard	DKBE long housings
4.2 - 5.2	5.2	E3 106.1/5.2	E3 106.3/5.2
5.2 - 6.2	6.2	E3 106.1/6.2	E3 106.3/6.2
6.2 - 7.2	7.2	E3 106.1/7.2	E3 106.3/7.2
7.2 - 8.2	8.2	E3 106.1/8.2	E3 106.3/8.2
8.2 - 9.2	9.2	E3 106.1/9.2	E3 106.3/9.2

Cable Ø range	Collet Ø	Cable clamp set ¹⁾ PTFE insulator	
		Standard	DKBE long housings
9.2 - 10.2	10.2	E3 106.1/10.2	E3 106.3/10.2
10.2 - 11.2	11.2	E3 106.1/11.2	E3 106.3/11.2
11.2 - 12.2	12.2	E3 106.1/12.2	E3 106.3/12.2
12.2 - 13.2	13.2	E3 106.1/13.2	E3 106.3/13.2
13.2 - 14.2	14.2	E3 106.1/14.2	E3 106.3/14.2

Cable Ø range	Collet Ø	Cable clamp set ¹⁾ PTFE insulator	
		Standard	DKBE long housings
14.2 - 15.2	15.2	E3 106.1/15.2	E3 106.3/15.2
15.2 - 16.2	16.2	E3 106.1/16.2	E3 106.3/16.2
16.2 - 17.2	17.2	E3 106.1/17.2	E3 106.3/17.2
17.2 - 18.2	18.2	E3 106.1/18.2	E3 106.3/18.2
18.2 - 19.2	19.2	E3 106.1/19.2	E3 106.3/19.2

Shielded cable clamps with washers and sleeves.

E
ENVIRONMENTAL

Environmentally sealed clamp for use with shielded or unshielded cables.

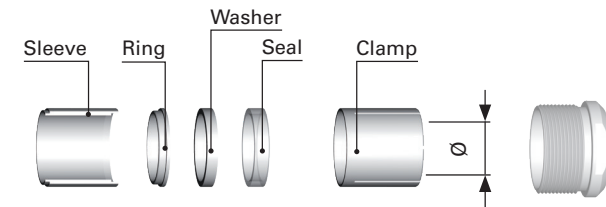

Cable Ø range	Collet Ø	Cable clamp set ¹⁾ PTFE insulator	
		Standard	DKBE long housings
4.2 - 5.2	5.2	E3 106.2/5.2	E3 106.4/5.2
5.2 - 6.2	6.2	E3 106.2/6.2	E3 106.4/6.2
6.2 - 7.2	7.2	E3 106.2/7.2	E3 106.4/7.2
7.2 - 8.2	8.2	E3 106.2/8.2	E3 106.4/8.2
8.2 - 9.2	9.2	E3 106.2/9.2	E3 106.4/9.2

Cable Ø range	Collet Ø	Cable clamp set ¹⁾ PTFE insulator	
		Standard	DKBE long housings
9.2 - 10.2	10.2	E3 106.2/10.2	E3 106.4/10.2
10.2 - 11.2	11.2	E3 106.2/11.2	E3 106.4/11.2
11.2 - 12.2	12.2	E3 106.2/12.2	E3 106.4/12.2
12.2 - 13.2	13.2	E3 106.2/13.2	E3 106.4/13.2
13.2 - 14.2	14.2	E3 106.2/14.2	E3 106.4/14.2

Cable Ø range	Collet Ø	Cable clamp set ¹⁾ PTFE insulator	
		Standard	DKBE long housings
14.2 - 15.2	15.2	E3 106.2/15.2	E3 106.4/15.2
15.2 - 16.2	16.2	E3 106.2/16.2	E3 106.4/16.2
16.2 - 17.2	17.2	E3 106.2/17.2	E3 106.4/17.2
17.2 - 18.2	18.2	E3 106.2/18.2	E3 106.4/18.2

¹⁾ For ordering information see page B2-40.

107 SERIES

S SHIELDED

Shielded cable clamp with sleeve, spacer and clamp.

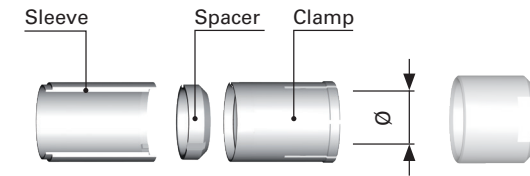

Cable Ø range	Collet Ø	Cable clamp set ¹⁾ PTFE insulator
5.7 - 7.2	7.2	E3 107.1/7.2
7.2 - 8.2	8.2	E3 107.1/8.2
8.2 - 9.2	9.2	E3 107.1/9.2
9.2 - 10.2	10.2	E3 107.1/10.2
10.2 - 11.2	11.2	E3 107.1/11.2

Cable Ø range	Collet Ø	Cable clamp set ¹⁾ PTFE insulator
11.2 - 12.2	12.2	E3 107.1/12.2
12.2 - 13.2	13.2	E3 107.1/13.2
13.2 - 14.2	14.2	E3 107.1/14.2
14.2 - 15.2	15.2	E3 107.1/15.2
15.2 - 16.2	16.2	E3 107.1/16.2

Cable Ø range	Collet Ø	Cable clamp set ¹⁾ PTFE insulator
16.2 - 17.2	17.2	E3 107.1/17.2
17.2 - 18.2	18.2	E3 107.1/18.2
18.2 - 19.2	19.2	E3 107.1/19.2
19.2 - 20.2	20.2	E3 107.1/20.2
20.2 - 21.2	21.2	E3 107.1/21.2
21.2 - 22.7	22.7	E3 107.1/22.7

E ENVIRONMENTAL

Environmentally sealed clamp for use with shielded or unshielded cables.

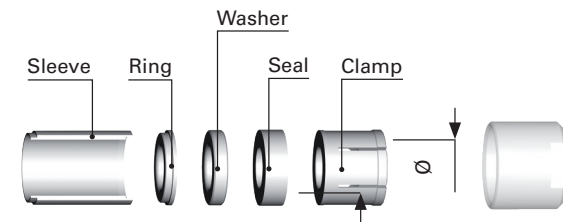

Cable Ø range	Collet Ø	Cable clamp set ¹⁾ PTFE insulator
5.7 - 7.2	7.2	E3 107.2/7.2
7.2 - 8.2	8.2	E3 107.2/8.2
8.2 - 9.2	9.2	E3 107.2/9.2
9.2 - 10.2	10.2	E3 107.2/10.2
10.2 - 11.2	11.2	E3 107.2/11.2

Cable Ø range	Collet Ø	Cable clamp set ¹⁾ PTFE insulator
11.2 - 12.2	12.2	E3 107.2/12.2
12.2 - 13.2	13.2	E3 107.2/13.2
13.2 - 14.2	14.2	E3 107.2/14.2
14.2 - 15.2	15.2	E3 107.2/15.2
15.2 - 16.2	16.2	E3 107.2/16.2

Cable Ø range	Collet Ø	Cable clamp set ¹⁾ PTFE insulator
16.2 - 17.2	17.2	E3 107.2/17.2
17.2 - 18.2	18.2	E3 107.2/18.2
18.2 - 19.2	19.2	E3 107.2/19.2
19.2 - 20.2	20.2	E3 107.2/20.2
20.2 - 21.2	21.2	E3 107.2/21.2
21.2 - 22.7	22.7	E3 107.2/22.7

¹⁾ For ordering information see page B2-40.

WSO 102, 103, 1031, 104 & 105 SERIES

S/U
SHIELDED/UNSHIELDED

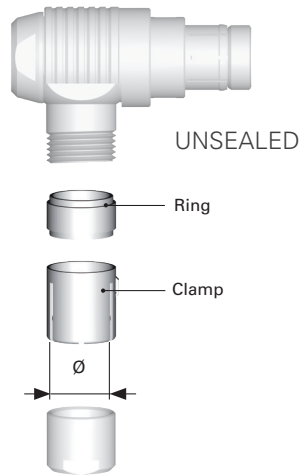

E
ENVIRONMENTAL

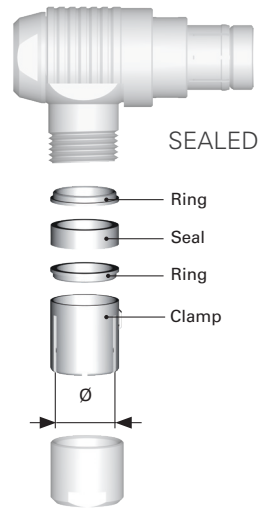

Series	Cable Ø range	Clamp Ø	Cable clamp set ¹⁾	
			Unsealed	Sealed
102	1.5 - 2.1	2.1	E3 102.12/2.1	E3 102.13/2.1
	2.1 - 2.6	2.6	E3 102.12/2.6	E3 102.13/2.6
	2.6 - 3.1	3.1	E3 102.12/3.1	E3 102.13/3.1
	3.1 - 3.6	3.6	E3 102.12/3.6	E3 102.13/3.6
	3.6 - 4.1	4.1	E3 102.12/4.1	E3 102.13/4.1
	4.1 - 4.3	4.3	E3 102.12/4.3	E3 102.13/4.3
	4.3 - 4.7	4.7	E3 102.12/4.7	-
103	1.7 - 2.2	2.2	E3 103.12/2.2	E3 103.13/2.2
	2.2 - 2.7	2.7	E3 103.12/2.7	E3 103.13/2.7
	2.7 - 3.2	3.2	E3 103.12/3.2	E3 103.13/3.2
	3.2 - 3.7	3.7	E3 103.12/3.7	E3 103.13/3.7
	3.7 - 4.2	4.2	E3 103.12/4.2	E3 103.13/4.2
	4.2 - 4.7	4.7	E3 103.12/4.7	E3 103.13/4.7
	4.7 - 5.2	5.2	E3 103.12/5.2	E3 103.13/5.2
	5.2 - 5.7	5.7	E3 103.12/5.7	E3 103.13/5.7
	5.7 - 6.2	6.2	E3 103.12/6.2	E3 103.13/6.2
	6.2 - 6.7	6.7	E3 103.12/6.7	-

Series	Cable Ø range	Clamp Ø	Cable clamp set ¹⁾	
			Unsealed	Sealed
1031	2.2 - 2.7	2.7	E3 1031.12/2.7	E3 1031.13/2.7
	2.7 - 3.2	3.2	E3 1031.12/3.2	E3 1031.13/3.2
	3.2 - 3.7	3.7	E3 1031.12/3.7	E3 1031.13/3.7
	3.7 - 4.2	4.2	E3 1031.12/4.2	E3 1031.13/4.2
	4.2 - 4.7	4.7	E3 1031.12/4.7	E3 1031.13/4.7
	4.7 - 5.2	5.2	E3 1031.12/5.2	E3 1031.13/5.2
	5.2 - 5.7	5.7	E3 1031.12/5.7	E3 1031.13/5.7
	5.7 - 6.2	6.2	E3 1031.12/6.2	E3 1031.13/6.2
	6.2 - 6.7	6.7	E3 1031.12/6.7	E3 1031.13/6.7
	6.7 - 7.2	7.2	E3 1031.12/7.2	-

Series	Cable Ø range	Clamp Ø	Cable clamp set ¹⁾	
			Unsealed	Sealed
104	2.9 - 4.0	4.0	E3 104.12/4.0	E3 104.13/4.0
	4.0 - 4.7	4.7	E3 104.12/4.7	E3 104.13/4.7
	4.7 - 5.7	5.7	E3 104.12/5.7	E3 104.13/5.7
	5.7 - 6.7	6.7	E3 104.12/6.7	E3 104.13/6.7
	6.7 - 7.7	7.7	E3 104.12/7.7	E3 104.13/7.7
	7.7 - 8.7	8.7	E3 104.12/8.7	E3 104.13/8.7

Series	Cable Ø range	Clamp Ø	Cable clamp set ¹⁾	
			Unsealed	Sealed
105	3.2 - 4.2	4.2	E3 105.12/4.2	E3 105.13/4.2
	4.2 - 5.2	5.2	E3 105.12/5.2	E3 105.13/5.2
	5.2 - 6.2	6.2	E3 105.12/6.2	E3 105.13/6.2
	6.2 - 7.2	7.2	E3 105.12/7.2	E3 105.13/7.2
	7.2 - 8.2	8.2	E3 105.12/8.2	E3 105.13/8.2
	8.2 - 9.2	9.2	E3 105.12/9.2	E3 105.13/9.2
	9.2 - 10.0	10.0	E3 105.12/10.0	E3 105.13/10.0
	10.0 - 10.7	10.7	E3 105.12/10.7	E3 105.13/10.7

¹⁾ For ordering information see page B 2-40.

B2-50 / B2-58

MULTIPOLE
HIGH VOLTAGE



PLUGS



CABLE MOUNTED

- Body styles (S; SA; SV) B2-51
- Technical dimensions B2-52

RECEPTACLES



PANEL MOUNTED

- Body styles (D; DEE; DBEE)..... B2-54
- Technical dimensions B2-55

FOR ALL MULTIPOLE HIGH VOLTAGE

- Electrical & contact configurations..... B2-57
- Options B2-35
- Insulating cable clamp sets B2-59
- Accessories B6-2
- Tooling B6-19
- Technical information..... B1-13
- Product specifications A-5

This catalog covers our standard connector solutions. For specific requests, including hybrid or custom connectors, please contact your local sales representative.

PLUGS

CABLE MOUNTED



Body style		S	SA	SV	References to detailed information
Protection	Unsealed (IP50)	●	●	●	Sealing categories, page A-6
	Sealed up to IP68	1)	1)	1)	
Locking system	Friction				Locking systems, page A-5
	Push-pull	●	●	●	
	Quick-release				
	Lanyard		●		
Contacts	Tamperproof			●	Electrical & contact configurations, page B 2-57
	Crimp				
Housing color	Solder	●	●	●	Options, page B 2-35
	Natural chrome	●	●	●	
Design	Black chrome	●	●		Body styles, chapter B 1-2
	Shortened body				
Cabling	Right-angle				Insulating cable clamps, B 2-59
	Cable clamp sets	●	●	●	
	Overmoldable				
Accessories	Heat shrinkable				Accessories, section B 6-2
	Cable bend reliefs	●	●	●	
	Protective sleeves	●	●	●	
Size	Sealing caps	●	●	●	Dimensions, page B 2-52
	102 Series				
	103 Series				
	1031 Series				
	104 Series	●	●	●	
	105 Series	●	●	●	
	106 Series	●		●	
107 Series	●		●		
					For more Information visit our website www.fischerconnectors.com/technical

¹⁾ Clamp sets for sealed or shielded connectors are available on request.

PLUGS

CABLE MOUNTED

S

BODY STYLE

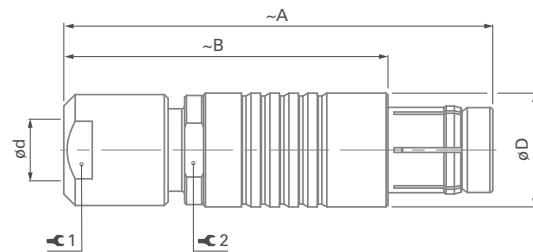

Series	A	B	D	d max	1	Torque 1 [Nm]	2
104	50	38	15	8.6	12	2.0	13
105	62	47	18	10.5	15	3.5	16
106	80	55	30	18.5	22	8.0	-
107	110	85	34	22.7	32	10.0	32

SA

BODY STYLE

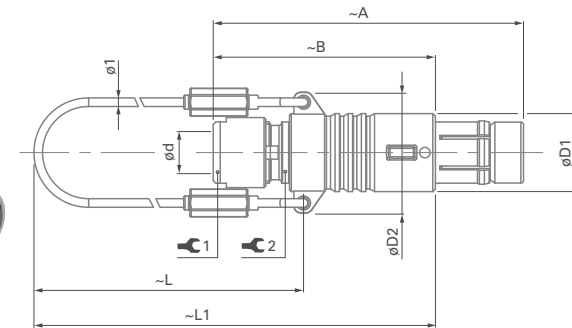

Series	A	B	D1	D2	L	L1	d max	1	Torque 1 [Nm]	2
104	50	38	15	21	65	83	8.6	12	2.0	13
105	62	47	18	25	70	96	10.5	15	3.5	16
106	Please contact us for additional information									
107										

PLUGS

CABLE MOUNTED

SV

BODY STYLE

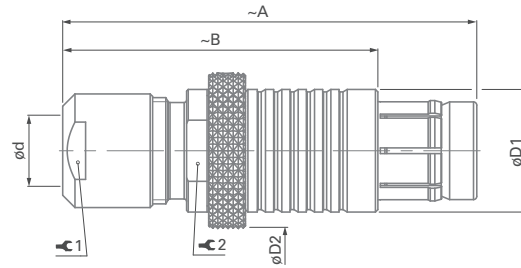

Series	A	B	D1	D2	d max	🔧 ₁	Torque 1 [Nm]	🔧 ₂
104	50	38	15	20	8.6	12	2.0	13
105	62	47	18	22	10.5	15	3.5	16
106	80	55	30	35	18.5	22	8.0	-
107	110	85	34	38	22.7	32	10	32

Torque [Nm] are recommended values that may be influenced by the characteristics of the cable jacket. Tests have to be made to evaluate the exact values. To secure the cable clamp nut, we recommend the use of thread locking adhesive.

RECEPTACLES

PANEL MOUNTED



Body style		D	DEE	DBEE	References to detailed information
Protection	Unsealed (IP50)	●			Sealing categories, page A-6
	Sealed up to IP68 ¹⁾		●	●	
	Hermetic ¹⁾		●	●	
Contacts	Crimp				Electrical & contact configurations, page B 2-57
	Solder	●	●	●	
	PCB				
Housing color	Natural chrome	●	●	●	Options, page B2-35
	Black chrome	●	●	●	
Design	Right-angle				Body styles, chapter B 1-3
	Flush	●	●		
	Front-projecting			●	
	Bulkhead feedthrough				
Assembly	Front-mounting	●	●	●	
	Rear-mounting				
Accessories	Sealing caps	●	●	●	Accessories, section B 6-2
	Spacers		●		
	Color-coded washers	●			
	Grounding washers	●	●	●	
	Locking washers	●	●	●	
Size	102 Series				Technical dimensions, page B2-55 For more Information visit our website www.fischerconnectors.com/technical
	103 Series				
	1031 Series				
	104 Series	●	●	●	
	105 Series	●	●	●	
	106 Series	●	●	●	
	107 Series	●	●	●	

¹⁾ Please contact us.

RECEPTACLES

PANEL MOUNTED

D

BODY STYLE

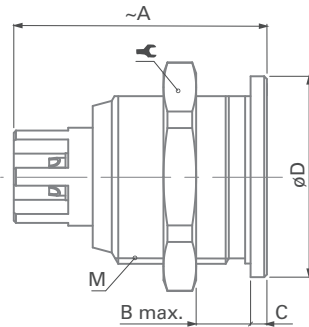

Series	A	B max.	C	D	M	⌘	Torque [Nm]
104	28	10.5	2.2	19	15x1	17	4.0
105	34	15.0	2	22	18x1	22	6.0
106	51	18.0	3	37	32x1	TX00.106	15
107	63	18.0	4	40	35x1	TX00.107	16

Receptacles of 106 and 107 Series are supplied with slotted nuts.

For nut dimensions see Accessories section B 6-2.

For wrenches see section Tooling section, page B 6-19.

Torque [Nm] are recommended values that may be influenced by the quality of the panel surface under the nut.

Tests have to be made to evaluate the exact values.

Other connector styles and contact configurations are available on request.

DEE

BODY STYLE

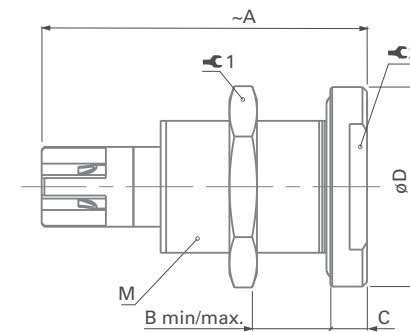
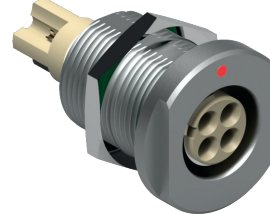

Series	A	B min/max.	C	D	M	⌘ ₁	Torque [Nm]	⌘ ₂
104	35	0/15.5	4	22	16x1	19	4.5	17
105	Please contact us for additional information							
106	54	19/24	5	41	32x1	TX00.106	15	–
107	64	19.2/22	5	45	35x1	TX00.107	16	–

RECEPTACLES

PANEL MOUNTED

DBEE

BODY STYLE

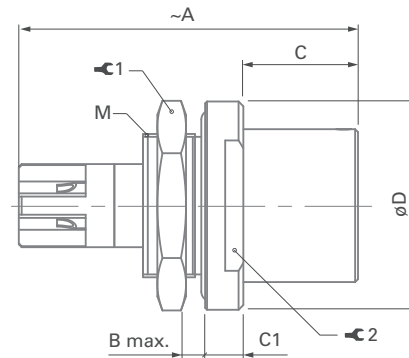
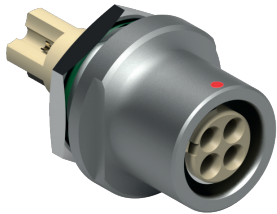

Series	A	B max.	C	C1	D	M	⚙ 1	Torque [Nm]	⚙ 2
104	35.5	3.5	16	4	22	16x1	19	4.5	17
105	Please contact us for additional information								
106	54	6.5	25.5	7	40	32x1	TX00.106	15	-
107	64	5	24	5	45	35x1	TX00.107	16	38

A/Z POLARITY

For Multipole High Voltage connectors, it is essential to pay attention to the differences between type "A" and "Z".

Type "A" standard polarity

The contacts of the receptacle are recessed to reduce the possibility of electric shock in the unmated position.

This version should be used when the voltage is sourced from the receptacle.

Type "Z" inverted polarity

The contacts of the plug are recessed to reduce the possibility of electric shock in the unmated position.

This version should be used when the voltage is sourced from the plug.

Protected contacts are usually female contacts recessed in the insulator.

For Multipole High Voltage connectors, however, it is safer to recess the male contacts. In these cases, the plug type "A" is equipped with female contacts and the receptacle with protected male contacts.

EXAMPLE

receptacle
type "A"
D 105 A039

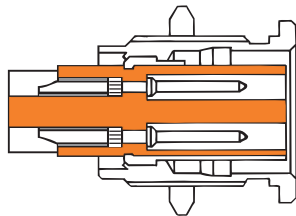

plug
type "A"
S 105 A039

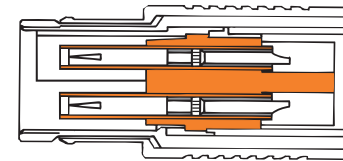

104, 105, 106 & 107 SERIES

● = Standard ○ = Option

Reference	Pin layout	Number of contacts	Contact termination		Insulating material	Contact ø [mm]	Wire barrel ø [mm]	Test voltage [kV] in mated position ⁴⁾				Current ¹⁾ [A]
			Solder	Crimp				AC rms		DC		
								Contact to body	Contact to contact	Contact to body	Contact to contact	
104 ^A _Z ⁵⁾ 062		4	●		PEEK ⁵⁾	0.9	0.8	4.5	4.0	7.5	6.0	8.0
105 A ⁶⁾ 057		3	●		PTFE	1.3	1.2	4.5	6.0	6.0	8.0	14
105 ^A _Z ⁷⁾ 039		5	●		PTFE	1.3	1.2	4.5	4.5	7.0	7.0	11
106 ^A _Z ⁸⁾⁹⁾ 013		6	●		PTFE	1.3	1.2	7.0	7.0	10.5	10.5	12
107A ²⁾³⁾¹⁰⁾ 034		7	●		PTFE	2.0	2.0	6.5	6.0	12.0	11.0	20

¹⁾ Current per contact at 40°C temperature rise measured on the basic curve according to IEC 60512-5-2-5b. For the max. operating current a reduction factor must be used and limitations due to the size of the wires and the permissible upper temperature limit of the materials employed must be taken into account. See page A-12 for details.

²⁾ For clamp sets selection see page B 2-47.

³⁾ See Tooling section, page B 6-24, for insertion tool of contacts.

⁴⁾ Measured with S plug and D receptacle.

⁵⁾ Only PTFE insulator and "A" polarity for DEE and DBEE body styles.

⁶⁾ Only available in D body style with "A" polarity.

⁷⁾ Only available in D body style. Contact us for other body style additional information.

⁸⁾ For DEE "A" polarity, the contact block is composed of two parts : one is PEEK and the second one is PTFE.

⁹⁾ DBEE only available with PEEK insulator and "A" polarity.

¹⁰⁾ Only available "A" polarity.

INSULATED CABLE CLAMP SETS



Multipole High Voltage connectors, as well as Mixed High Voltage and Mixed Coax connectors, are equipped with POM (Delrin®) collet type cable clamps.

These insulated one-piece clamps are fitted for optimal High-Voltage ratings.

Material

POM (Polyoxymethylene) Delrin®

Insulating cable clamp set is included with connector		
Multipole high voltage	Mixed high voltage	Mixed coax
Insulating clamp set ø should be added to the connector part number separated by ø (select the collet ø according to the cable clamping range) and followed by-UI (Unshielded Insulated).		
Example		
S 104 A062-130 ø 6.6-UI		

104 series 4 pole high voltage S plug with insulating cable clamp set allowing cable diameter included between 4.7 & 6.6 mm

CONNECTOR TYPES WITH INSULATING CABLE CLAMP SETS

Series	Multipole high voltage	Mixed high voltage	Mixed coax
104	104 $\frac{A}{Z}$ 062	104 $\frac{A}{Z}$ 083	104 A 078
			104 A 093
105	105 $\frac{A}{Z}$ 039	105 A 020	105 A 074
	105 A 057	105 A 036	105 A 089
		105 A 060	105 A 095
		105 A 112	
106	106 $\frac{A}{Z}$ 013	106 A 014	
107	Insulating cable clamps set, not available. See page B2-47.		

Series	Cable dia. range	Collet Ø
104	2.4 - 3.4	3.4
	3.0 - 4.0	4.0
	3.6 - 4.6	4.6
	4.7 - 5.7	5.7
	4.7 - 6.6	6.6
	5.8 - 7.7	7.7
	6.2 - 8.1	8.1
	6.7 - 8.6	8.6
105	2.8 - 4.2	4.2
	4.1 - 5.5	5.5
	5.1 - 6.5	6.5
	6.1 - 7.5	7.5
	6.6 - 8.0	8.0
	7.1 - 8.5	8.5
	8.3 - 9.7	9.7
	9.1 - 10.5	10.5

Series	Cable dia. range	Collet Ø
106	4.3 - 5.7	5.7
	5.3 - 6.7	6.7
	5.8 - 7.2	7.2
	7.8 - 9.2	9.2
	9.8 - 11.2	11.2
	11.8 - 13.2	13.2
	13.8 - 15.2	15.2
	14.8 - 17.2	17.2
	17.1 - 18.5	18.5
107	Insulating cable clamps set. Not available. See page B2-48	

B3

CHAPTER

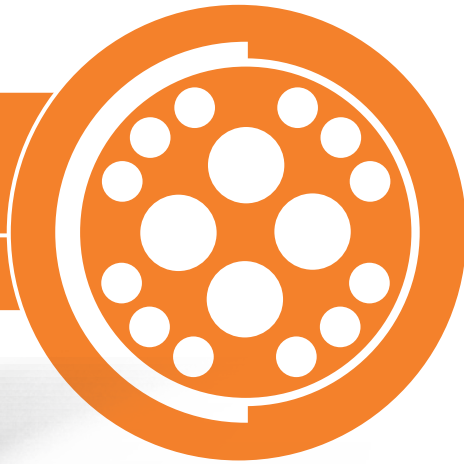

FISCHER CORE SERIES **BRASS** **COAX**

- LOW VOLTAGE.....B3-2
- HIGH VOLTAGE.....B3-28



COAX
LOW & HIGH
VOLTAGE

B3-2 / B3-27

COAX
LOW VOLTAGE



PLUGS



CABLE MOUNTED

- Body styles (S/SC; SE/SCE; SOV/SOVE; SA/SAE; SV/SVE; WSO) B3-3
- Technical dimensions B3-4



PANEL MOUNTED

- Body styles (SF; SFU/E; SFPU/E) B3-16
- Technical dimensions B3-17

RECEPTACLES



CABLE MOUNTED

- Body styles (K/KE) B3-7
- Technical dimensions B3-8



PANEL MOUNTED

- Body styles (D; DEU/E; DB; DBEU/E; DBP; DBPU/E; DBPLU/E; DG; WDE)..... B3-9
- Technical dimensions B3-11



PANEL MOUNTED CABLE

- Body styles (DKBE; DK; DKE) B3-19
- Technical dimensions B3-20

FOR ALL COAX LOW VOLTAGE

- Electrical & contact configurations..... B3-22
- Cable designation B3-24
- Options B3-26
- Cable clamp sets included in product except for WSO B2-39
- Accessories B6-2
- Tooling B6-19
- Technical information B1-13
- Product specifications A-5

This catalog covers our standard connector solutions. For specific requests, including hybrid or custom connectors, please contact your local sales representative.

PLUGS

CABLE MOUNTED

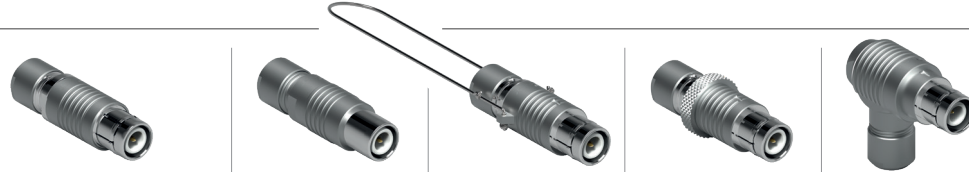

Body style		S	SE ¹⁾	SC	SCE ¹⁾	SOV	SOVE ¹⁾	SA	SAE ¹⁾	SV ¹⁾	SVE	WSO	References to detailed information
Protection	Unsealed (IP50)	●		●		●		●		●		●	Sealing categories, page A-6
	Sealed up to IP68		●		●		●		●		●	●	
Locking system	Friction					●	●						Locking systems, page A-5
	Push-pull	●	●					●	●	●	●	●	
	Quick-release			●	●								
	Lanyard							●	●				
	Tamperproof									●	●		
Contacts	Crimp												Electrical & contact configurations, page B3-22
	Solder	●	●	●	●	●	●	●	●	●	●	●	
Housing color	Natural chrome	●	●	●	●	●	●	●	●	●	●	●	Options, page B3-26
	Black chrome	●	●	●	●	●	●	●	●			●	
Design	Shortened body												Body styles, page B1-2
	Right-angle											●	
Cabling	Cable clamp sets	●	●	●	●	●	●	●	●	●	●	●	Cable clamp set included in product except for WSO, page B2-39
	Overmoldable												
	Heat shrinkable												
Accessories	Cable bend reliefs	●	●	●	●	●	●	●	●	●	●	●	Accessories, page B6-2
	Protective sleeves	●	●	●	●	●	●						
	Sealing caps	●	●	●	●	●	●	●	●	●	●	●	
Size	102 Series	●	●	●	●	●	●	●	●	●	●	●	Technical dimensions, page B3-4
	103 Series	●	●	●	●	●	●	●	●	●	●	●	
	1031 Series												
	104 Series	●	●	●	●	●	●	●	●	●	●	●	For more information visit: www.fischerconnectors.com/technical
	105 Series	●	●	●	●	●	●	●	●	●	●	●	
	106 Series												
	107 Series												

¹⁾ Environmental cable clamp set included.

PLUGS

CABLE MOUNTED

S/SE/SC/SCE

BODY STYLES

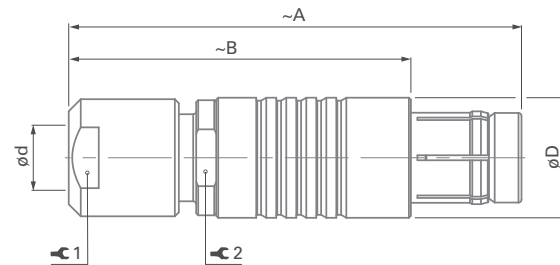

Series	A	B	D	dmax		1	Torque 1 [Nm]	2
				Unsealed	Sealed			
102	36	26	9	4.7	4.3	7	0.6	7
103	46	35	12	6.7	6.7	10	1.0	10
104	50	38	15	8.7	8.7	12	2.0	13
105	62	47	18	10.7	10.7	15	3.5	16

SOV/SOVE

BODY STYLE

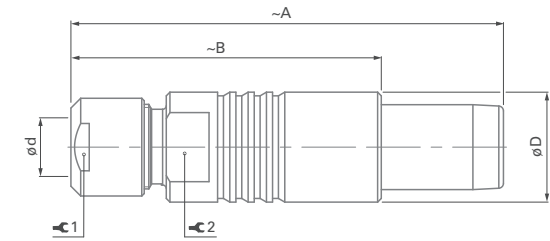

Series	A	B	D	dmax		1	Torque 1 [Nm]	2
				Unsealed	Sealed			
102	36	26	9	4.7	4.3	7	0.6	7
103	46	35	12	6.7	6.7	10	1.0	10
104	50	38	15	8.7	8.7	12	2.0	13
105	62	47	18	10.7	10.7	15	3.5	16

Torque [Nm] are recommended values that may be influenced by the characteristics of the cable jacket. Tests have to be made to evaluate the exact values. To secure the cable clamp nut, we recommend the use of thread locking adhesive.

PLUGS

CABLE MOUNTED

SA/SAE

BODY STYLE

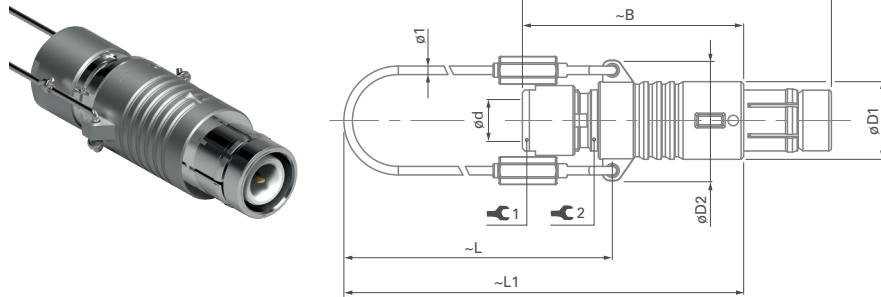

Series	A	B	D1	D2	L	L1	d _{max}		⌀ 1	Torque 1 [Nm]	⌀ 2
							Unsealed	Sealed			
102	36	26	9	14	50	65	4.7	4.3	7	0.6	7
103	46	35	12	17	60	77	6.7	6.2	10	1.0	10
104	50	38	15	21	65	84	8.7	8.7	12	2.0	13
105	62	47	18	25	70	94	10.7	10.7	15	3.5	16

Torque [Nm] are recommended values that may be influenced by the characteristics of the cable jacket. Tests must be conducted to evaluate the exact values. To secure the cable clamp nut, we recommend the use of thread locking adhesive.

SV/SVE

BODY STYLE

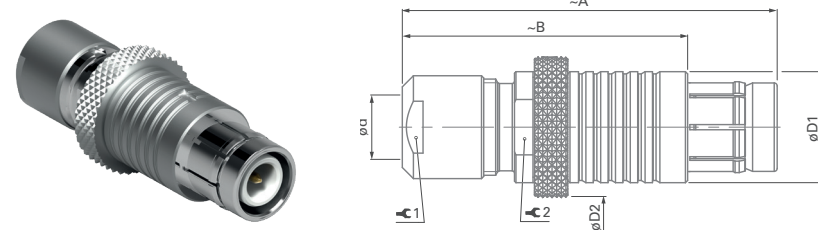

Series	A	B	D1	D2	d _{max}		⌀ 1	Torque 1 [Nm]	⌀ 2
					Unsealed	Sealed			
102	36	26	9	11	4.7	4.3	7	0.6	-
103	46	35	12	13	6.7	6.2	10	1.0	-
104	50	38	15	20	8.7	8.7	12	2.0	13
105	62	47	18	22	10.7	10.7	15	3.5	16

PLUGS

CABLE MOUNTED

WSO

BODY STYLE

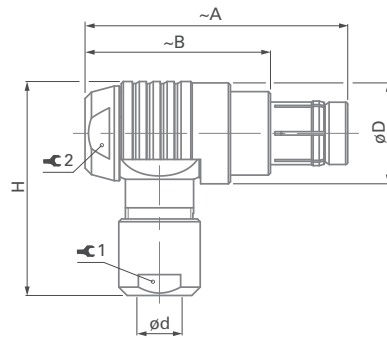

Series	A	B	D	H	dmax		⚙️ 1	Torque 1 [Nm]	⚙️ 2	Torque 2 [Nm]
					Unsealed	Sealed				
102	33	23	12	25	4.7	4.3	7	0.6	8	1.0
103	38	27	15	31	6.7	6.2	10	1.0	11	1.3
104	45	32	19	37	8.7	8.7	12	2.0	14	2.5
105	53	38	23	45	10.7	10.7	15	3.5	17	3.5

RECEPTACLES

CABLE MOUNTED



Body style		K	KE ¹⁾	References to detailed information
Protection	Unsealed (IP50)	●		Sealing categories, page A-6
	Sealed up to IP68		●	
Contacts	Crimp			Electrical & contact configurations, page B3-22
	Solder	●	●	
Housing	Natural chrome	●	●	Options, page B3-26 Body styles, page B1-3
	Black chrome	●	●	
	Shortened body			
Cabling	Cable clamp sets	●	●	Cable clamp set included in product, pages B2-39
	Overmoldable			
	Heat shrinkable			
Accessories	Cable bend reliefs	●	●	Accessories, page B6-2
	Protective sleeves	●	●	
	Sealing caps	●	●	
Size	102 Series	●	●	Technical dimensions, page B3-8 For more information visit: www.fischerconnectors.com/technical
	103 Series	●	●	
	1031 Series			
	104 Series	●	●	
	105 Series	●	●	
	106 Series			
107 Series				

¹⁾ Environmental cable clamp set included.

RECEPTACLES

CABLE MOUNTED

K/KE

BODY STYLES

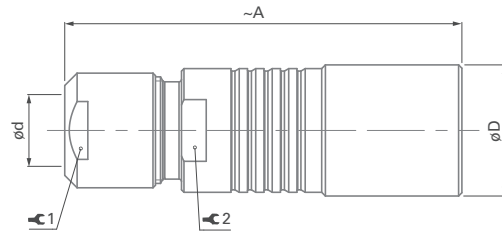

Series	A	B	dmax		Torque 1 [Nm]	Torque 2
			Unsealed	Sealed		
102	35	10	4.7	4.3	0.6	7
103	43	13	6.7	6.2	1.0	10
104	50	16	8.7	8.7	2.0	13
105	60	19	10.7	10.7	3.5	16

Recommended values that may be influenced by the characteristics of the cable jacket.

Tests must be conducted to evaluate the exact values. To secure the cable clamp nut, we recommend the use of thread locking adhesive.

RECEPTACLES

PANEL MOUNTED



Body style		D	DEU	DEE	DB	DBEU	DBEE	DBP	References to detailed information
Protection	Unsealed (IP50)	●			●			●	Sealing categories, page A-6
	Sealed up to IP68		●	●		●	●		
	Hermetic			●			●		
Contacts	Crimp								Electrical & contact configurations, page B3-22
	Solder	●	●	●	●	●	●	●	
	PCB								
Housing color	Natural chrome	●	●	●	●	●	●	●	Options, page B3-26
	Black chrome	●	●	●	●	●	●	●	
Design	Right-angle								Body style selection, page B 1-3
	Flush	●	●	●				●	
	Front projecting				●	●	●		
	Bulkhead feedthrough								
Assembly	Front-mounting	●	●	●	●	●	●		
	Rear-mounting							●	
Accessories	Sealing caps	●	●	●	●	●	●	●	Accessories, page B6-2
	Spacers		●	●					
	Color-coded washers	●			●			●	
	Grounding washers	●	●	●	●	●	●	●	
	Locking washers	●	●	●	●	●	●	●	
Size	102 Series	●	●	●	●	●	●	●	Technical dimensions, page B3-11 For more information visit: www.fischerconnectors.com/technical
	103 Series	●	●	●	●	●	●	●	
	1031 Series								
	104 Series	●	●	●	●	●	●	●	
	105 Series	●	●	●	●	●	●	●	
	106 Series								
	107 Series								

COAX
LOW & HIGH
VOLTAGE

RECEPTACLES

PANEL MOUNTED



Body style		DBPU	DBPE	DBPLU	DBPLE	DG	WDE	References to detailed information
Protection	Unsealed (IP50)					●		Sealing categories, page A-6
	Sealed up to IP68	●	●	●	●		●	
	Hermetic		●		●		●	
Contacts	Crimp							Electrical & contact configurations, page B3-22
	Solder	●	●	●	●	●	●	
	PCB							
Housing color	Natural chrome	●	●	●	●	●	●	Options, page B3-26
	Black chrome	●	●	●	●	●	●	
Design	Right-angle							Body styles, page B 1-3
	Flush	●	●			●	●	
	Front projecting			●	●	●	●	
	Bulkhead feedthrough						●	
Assembly	Front-mounting					●	●	
	Rear-mounting	●	●	●	●	●		
Accessories	Sealing caps	●	●	●	●	●	●	Accessories, page B 6-2
	Spacers						●	
	Color-coded washers					●		
	Grounding washers	●	●			●		
	Locking washers	●	●	●	●	●		
Size	102 Series	●	●	●	●	●	●	Technical dimensions, page B3-13
	103 Series	●	●	●	●	●	●	
	1031 Series							
	104 Series	●	●	●	●	●	●	
	105 Series	●	●	●	●	●	●	
	106 Series							
107 Series								

For more information visit:
www.fischerconnectors.com/technical

COAX
LOW & HIGH
VOLTAGE

RECEPTACLES

PANEL MOUNTED

D

BODY STYLE

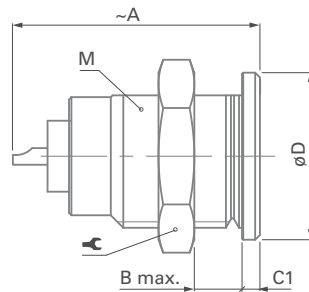

Series	A	B max.	C1	D	M	⚙️	Torque 1 [Nm]
102	19	9	1.5	11	9x0.5	11	1.3
103	23	8	1.5	14	12x1	14	2.5
104	25	11	2.2	19	15x1	17	4.0
105	32	15	2.0	22	18x1	22	6.0

Torque [Nm] are recommended values that may be influenced by the quality of the panel surface under the nut. Tests must be conducted to evaluate the exact values.

DEU/DEE

BODY STYLES

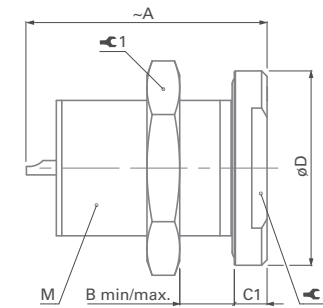
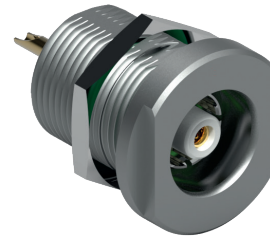

Series	A	B min./max.	C1	D	M	⚙️ 1	Torque 1 [Nm]	⚙️ 2
102	20	8/10	2.5	14	9x0.5	11	1.3	-
103	23	0/12	3.0	18	14x1	17	3.0	14
104	25	0/15	4.0	22	16x1	19	4.5	17
105	33	10.5/18	4.0	27	20x1	25	6.5	-

RECEPTACLES

PANEL MOUNTED

DB

BODY STYLE

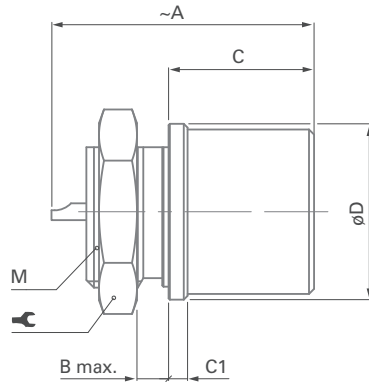

Series	A	B max.	C	C1	D	M	⚙	Torque [Nm]
102	18	3	11.0	1.0	11	9x0.5	11	1.3
103	21	4	11.5	1.5	14	12x1	14	2.5
104	26	3	14.5	2.5	19	16x1	19	4.5
105	33	7	19.0	2.0	22	18x1	22	6.0

DBEU/DBEE

BODY STYLES

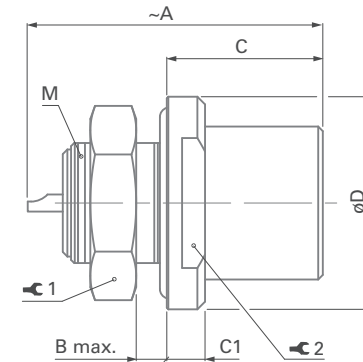

Series	A	B max.	C	C1	D	M	⚙ ₁	Torque 1 [Nm]	⚙ ₂
102	20	3.5	10.2	2.5	14	9x0.5	11	1.3	-
103	23	4.0	13.0	3.0	18	14x1	17	3.0	14
104	30	3.5	16.0	4.0	22	16x1	19	4.5	17
105	32	5.0	19.0	4.0	27	18x1	22	6.0	22

RECEPTACLES

PANEL MOUNTED

DBP

BODY STYLE

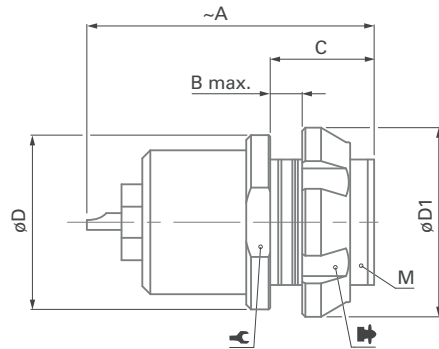

DBPU/DBPE

BODY STYLES

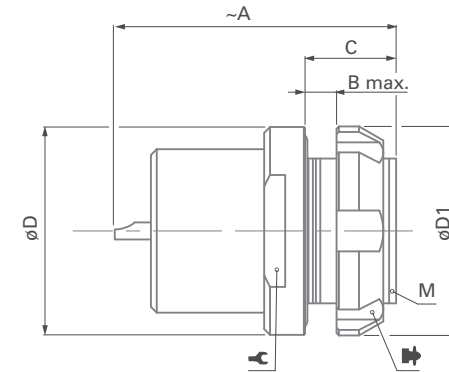

Series	A	B max.	C	D	D1	M			Torque [Nm]
102	20	3.5	6.5	11	12	9x0.5	10	TC00.000	1.3
103	23	4.0	8.0	14	15	12x1	-	TF00.001	2.5
104	26	5.0	9.0	19	19	15x1	-	TK00.000	4.0
105	30	12.0	17.0	22	23	18x1	-	TP00.011	6.0

Series	A	B max.	C	D	D1	M			Torque [Nm]
102	20	3.5	6.5	14	12	9x0.5	11	TC00.000	1.3
103	26	3.0	7.8	18	18	14x1	15	TG00.001	3.0
104	26	4.0	8.0	22	20	16x1	-	TK00.002	4.5
105	30	5.0	10.0	27	25	20x1	-	TP00.005	6.5

¹⁾ Assembly tool for decorative slotted nut, see Tooling section, page B 6-20 for details.

Torque [Nm] are recommended values that may be influenced by the quality of the panel surface under the nut.

Tests must be conducted to evaluate the exact values.

RECEPTACLES

PANEL MOUNTED

DBPLU/DBPLE

BODY STYLES

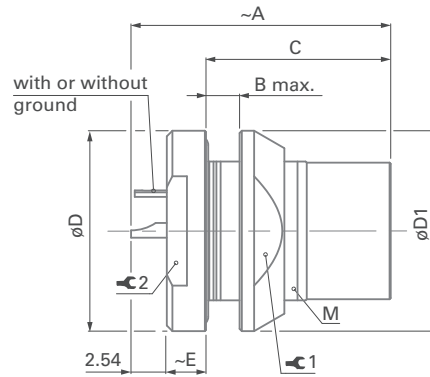

Series	A	B max.	C	D	D1	M	1	Torque 1 [Nm]	2
102	21	4.5	14.2	14	13	10x0.5	11	1.5	11
103	24	5.0	16.5	18	18	14x1	15	3.0	15
104	27	6.5	18.5	22	20	16x1	17	4.5	17
105	31	7.0	22.5	27	25	20x1	22	6.5	22

¹⁾ Assembly tool for decorative slotted nut, see Tooling section, page B 6-20, for details.

DG

BODY STYLE

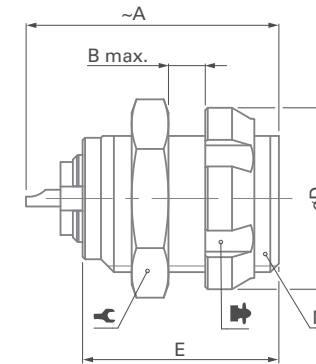

Series	A	B max.	D	E	M	1	¹⁾	Torque [Nm]
102	20	6	12	14	9x0.5	11	TC00.000	1.3
103	23	7	15	15	12x1	14	TF00.001	2.5
104	26	9	19	18	15x1	17	TK00.000	4.0
105	30	15	23	24	18x1	22	TP00.011	6.0

RECEPTACLES

PANEL MOUNTED

WDE FOR 102, 103 & 104 SERIES

BODY STYLE

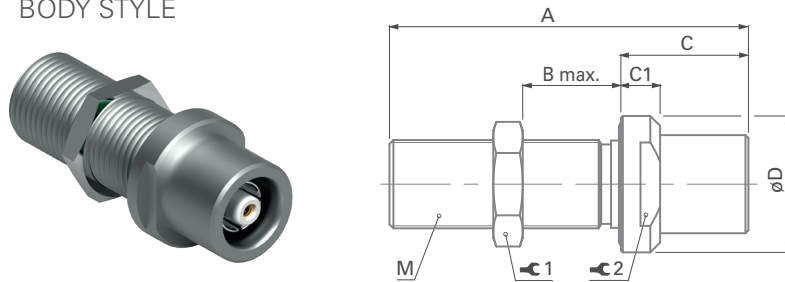

Series	A	B _{max}	C	C1	D	M	⚙️ 1	Torque 1 [Nm]	⚙️ 2
102	39	23	13	4	14	9x0.5	11	1.3	11
103	40	23	14	4	17	12x1	14	2.5	14
104	40	21	16	4	22	15x1	17	4.0	17

The bulkhead feedthrough connector allows the passing of electrical signals and power through a panel via two cable plugs.

The "AZ" version of the feedthrough accepts a type "A" plug on the flange side and a type "Z" plug on the threaded end, which is typically oriented toward the interior of the chassis. In the version "ZA", the connections "A" and "Z" are inverted, see "A/Z Polarity" on page A-10.

Dimension "B max" specifies the maximum panel thickness.

WDE FOR 105 SERIES

BODY STYLE

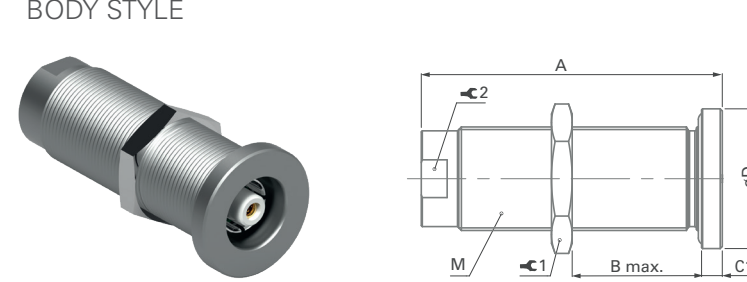

Series	A	B _{max}	C	C1	D	M	⚙️ 1	Torque 1 [Nm]	⚙️ 2
105	62	47	-	4	27	20x1	22	6.5	-

PLUGS

PANEL MOUNTED



COAX
LOW & HIGH
VOLTAGE

Body style		SF	SFU	SFE	SFPU	SFPE	References to detailed information
Protection	Unsealed (IP50)	●					Sealing categories, page A-6
	Sealed up to IP68		●	●	●	●	
	Hermetic			●		●	
Contacts	Crimp						Electrical & contact configurations, page B3-22
	Solder	●	●	●	●	●	
	PCB						
Housing color	Natural chrome	●	●	●	●	●	Options, page B3-26
	Black chrome	●	●	●	●	●	
Assembly	Front-mounting	●	●	●			Body styles, page B1-2
	Rear-mounting				●	●	
Accessories	Sealing caps	●	●	●	●	●	Accessories, page B6-2
	Spacers						
	Color-coded washers	●					
	Insulating washers	●					
	Grounding washers	●	●	●			
Size	Locking washers	●	●	●	●	●	Technical dimensions, page B3-17 For more information visit: www.fischerconnectors.com/technical
	102 Series	●	●	●	●	●	
	103 Series	●	●	●	●	●	
	1031 Series						
	104 Series	●	●	●	●	●	
	105 Series	●	●	●	●	●	
	106 Series						
107 Series							

PLUGS

PANEL MOUNTED

SF

BODY STYLE

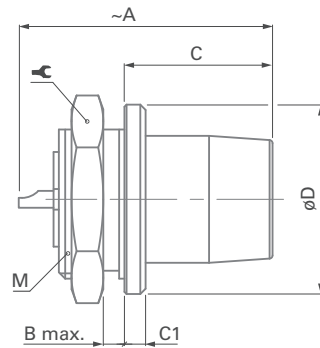

Series	A	B max.	C	C1	D	M	⌘	Torque [Nm]
102	20.0	4.0	11.0	1.0	10	9x0.5	11	1.3
103	23.5	3.0	12.5	1.5	14	12x1	14	2.5
104	28.0	3.0	14.0	2.0	18	15x1	17	4.0
105	30.5	5.5	16.8	1.2	22	16x1	19	4.5

Torque [Nm] are recommended values that may be influenced by the quality of the panel surface under the nut. Tests must be conducted to evaluate the exact values.

SFU/SFE

BODY STYLES

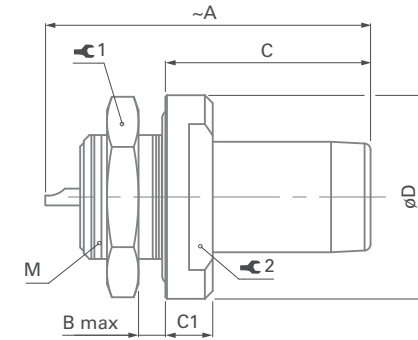
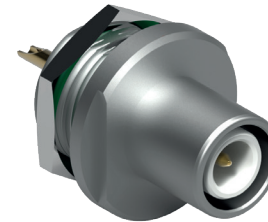

Series	A	B max.	C	C1	D	M	⌘ 1	Torque 1 [Nm]	⌘ 2
102	21	2.5	13	3	13	9x0.5	11	1.3	9
103	26	5.0	14	3	17	12x1	14	2.5	12
104	28	7.5	15	3	22	16x1	19	4.5	-
105	32	6.0	19	4	27	20x1	25	6.5	-

All dimensions and images shown are in millimeters and are for reference only.

PLUGS

PANEL MOUNTED

SFPU/SFPE

BODY STYLES

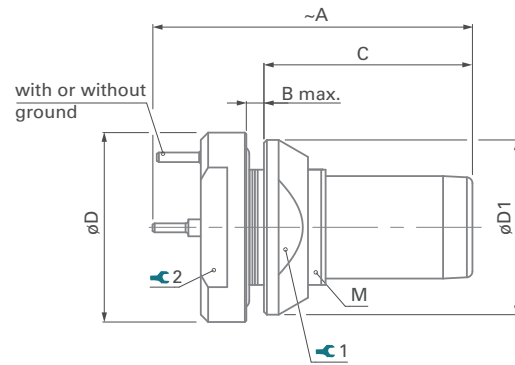

Series	A	B max.	C	D	D1	M	🔧 ₁	Torque 1 [Nm]	🔧 ₂
102	26.0	2.5	15.4	13	12	9x0.5	10	1.3	9
103	29.5	4.0	18.5	17	16	12x1	13	2.5	12
104	33.0	6.0	22.0	22	20	16x1	17	4.5	17
105	36.5	5.0	25.0	27	25	20x1	22	6.5	19

RECEPTACLES

PANEL MOUNTED CABLE



Body style		DKBE ¹⁾	DK	DKE ¹⁾	Links to detailed information
Protection	Unsealed (IP50)		●		Sealing categories, page A-6
	Sealed up to IP68	●		●	
Contacts	Crimp				Electrical & contact configurations, page B3-22
	Solder	●	●	●	
Housing color	Natural chrome	●	●	●	Options, page B3-26
	Black chrome	●	●	●	
Design	Flush		●		Body styles, page B 1-3
	Front-projecting	●		●	
Assembly	Panel-mounted	●	●	●	
	Front-mounting		●	●	
	Rear-mounting	●			
	Cable mounted	●	●	●	
	Cable clamp sets	●	●	●	Cable clamp set included in product, pages B2-39
Accessories	Cable bend reliefs	●	●	●	Accessories, page B6-2
	Sealing caps	●	●	●	
	Spacers			●	
	Color-coded washers	●	●	●	
	Insulating washers				
	Grounding washers	●	●	●	
Size	Locking washers	●	●	●	Technical dimensions, page B3-20 For more information visit: www.fischerconnectors.com/technical
	102 Series	●	●	●	
	103 Series	●	●	●	
	1031 Series				
	104 Series	●	●	●	
	105 Series	●	●	●	
	106 Series				
107 Series					

¹⁾ Environmental cable clamp set included.

RECEPTACLES

PANEL MOUNTED CABLE

DKBE

BODY STYLE

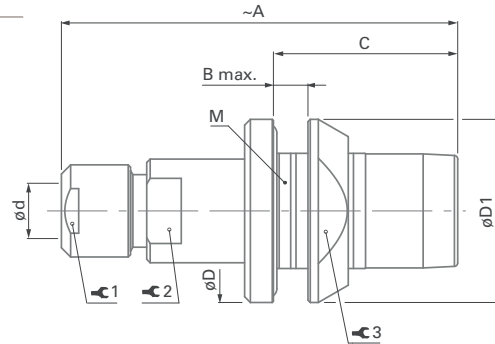

Series	A	B max.	C	D	dmax	D1	M
102	35	3.5	16.0	16	4.3	16	12x1
103	43	4.0	19.0	19	6.2	20	15x1
104	50	5.0	22.5	23	8.7	23	18x1
105	60	5.0	26.0	28	10.7	27	22x1

Series	⌘ ₁	Torque 1 [Nm]	⌘ ₂	⌘ ₃	Torque 3 [Nm]
102	7	0.6	7	13	2.5
103	10	1.0	10	17	4.0
104	12	2.0	13	20	6.0
105	15	3.5	16	24	8.0

Torque [Nm] are recommended values that may be influenced by the characteristics of the cable jacket. Tests have to be made to evaluate the exact values. To secure the cable clamp nut, we recommend the use of thread locking adhesive.

DK

BODY STYLE

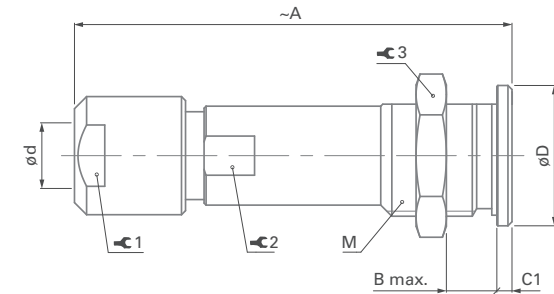

Series	A	B max.	C1	D	dmax	M
102	35	9	1.5	11	4.7	9x0.5
103	44	10	1.5	14	6.7	12x1
104	50	11	2.0	19	8.7	15x1
105	60	16	2.0	22	10.7	18x1

Series	⌘ ₁	Torque 1 [Nm]	⌘ ₂	⌘ ₃	Torque 3 [Nm]
102	7	0.6	-	11	1.3
103	10	1.0	9	14	2.5
104	12	2.0	12	17	4.0
105	15	3.5	14	22	6.0

RECEPTACLES

PANEL MOUNTED CABLE

DKE FOR 102 & 103 SERIES

BODY STYLES

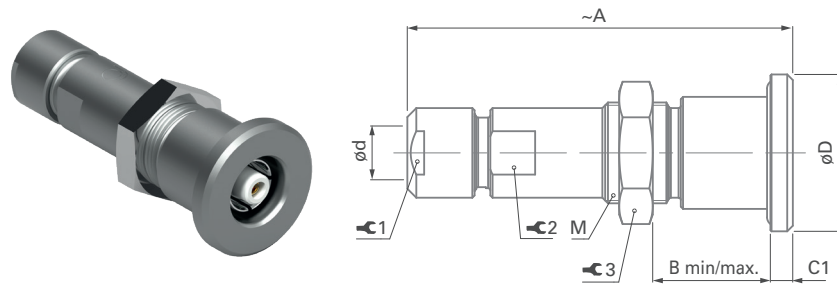

Series	A	B min/max.	C	C1	D	dmax	M
102	35	9/12	-	2	14	4.3	9x0.5
103	45	9/14	-	3	17	6.2	14x1

Series	⌘ 1	Torque 1 [Nm]	⌘ 2	⌘ 3	Torque 3 [Nm]
102	7	0.6	7	11	1.3
103	10	1.0	10	17	3.0

DKE FOR 104 & 105 SERIES

BODY STYLES

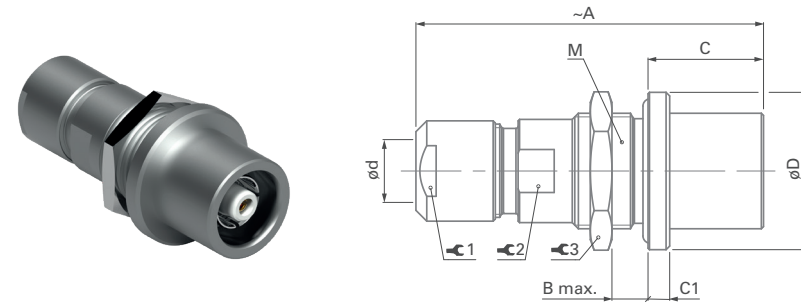

Series	A	B max.	C	C1	D	dmax	M
104	50	8	16.0	3	22	8.7	16x1
105	61	9	19.0	4	27	10.7	20x1

Series	⌘ 1	Torque 1 [Nm]	⌘ 2	⌘ 3	Torque 3 [Nm]
104	12	2.0	13	19	4.5
105	15	3.5	16	25	6.5

All dimensions and images shown are in millimeters and are for reference only.

102 & 103 SERIES

● = Standard ○ = Option

Reference	Pin layout	Contact types		Insulating material	Cable group ¹⁾	Contact ø [mm]	Wire barrel ø [mm]	Impedance [ohms]	Test voltage ³⁾ [kV] in mated position				Current ²⁾ [A]
		Solder ⁵⁾	Crimp						AC r.m.s.		DC		
									Contact to body	Contact to contact	Contact to body	Contact to contact	
102 A 001		●		PTFE	1/3/5	1.6	1.2	-	1.8	-	2.5	-	14
102 A Z 002		●		PTFE	1/2/3	0.9	0.8	50	3.0	-	5.0	-	10
102 A 017		●		PTFE ⁴⁾	1/2/3	0.7	0.6	75	1.7	-	2.8	-	7.0
103 A Z 001		●		PTFE	3/4/5	2.0	2.0	-	2.2	-	4.2	-	19
103 A Z 002		●		PTFE	1/2/6	1.3	1.2	75	3.8	-	5.4	-	12
103 A 026		●		PTFE	4/5/6	1.6	1.9	50	1.8	-	2.4	-	15

¹⁾ See list of recommended cables on page B3-24.

²⁾ Current per contact at 40°C temperature rise measured on the basic curve according to IEC 60512-5-2-5b. For the max. operating current a reduction factor must be used and limitations due to the size of the wires and the permissible upper temperature limit of the materials employed must be taken into account. See page A-12 for details.

³⁾ Measured with S plug and D receptacle. Please contact us for ratings for WSO right-angle plugs and WDE bulkhead feedthroughs.

⁴⁾ PEEK is mainly used for hermetic connectors.

⁵⁾ Solder contact version of DBPLE/DBPLU with ground contact: Ground contact for wire size: max 0.79mm / AWG 21 [1] / AWG 22 [7/30].

104 & 105 SERIES

● = Standard ○ = Option

Reference	Pin layout	Contact types		Insulating material	Cable group ¹⁾	Contact ø [mm]	Wire barrel ø [mm]	Impedance [ohms]	Test voltage ³⁾ [kV] in mated position				Current ²⁾ [A]
		Solder ⁵⁾	Crimp						AC r.m.s.		DC		
									Contact to body	Contact to contact	Contact to body	Contact to contact	
104 A 002		●		PTFE	6/7	1.6	1.9	75	4.8	-	6.8	-	15
104 A 060		●		PTFE ⁴⁾	4/5/6/7	2.0	1.9	50	4.5	-	6.5	-	13
105 ^A / _Z 002		●		PTFE ⁴⁾	5/6/7/8	3.0	2.8	50	4.8	-	7.0	-	30
105 ^A / _Z 090		●		PTFE	6/7	1.3	1.2	75	6.4	-	11	-	13

¹⁾ See list of recommended cables on page B3-24.

²⁾ Current per contact at 40°C temperature rise measured on the basic curve according to IEC 60512-5-2-5b. For the max. operating current a reduction factor must be used and limitations due to the size of the wires and the permissible upper temperature limit of the materials employed must be taken into account. See page A-12 for details.

³⁾ Measured with S plug and D receptacle. Please contact us for ratings for WSO right-angle plugs and WDE bulkhead feedthroughs.

⁴⁾ PEEK is mainly used for hermetic connectors.

⁵⁾ Solder contact version of DBPLE/DBPLU with ground contact: Ground contact for wire size: max 0.79mm / AWG 21 [1] / AWG 22 [7/30].

FOR COAX, TRIAX & MIXED COAX CONNECTORS

Gr. No	Designation US MIL-C-17	Impedance ohms	Center conductor		Dielectric		Cable screen		Cable jacket		IEC publication 60096-2 or manufacturer	
			Construction	ø [mm]	ø [mm]	Material	ø [mm]	Material	ø [mm]	Material		
0	RG-178B/U	50±2	7 x 0.1	AcCuAg	0.3	0.84	PTFE	1.3	CuAg	1.8	FEP	50-1-1 50-1-2
	RG-196A/U	50±2	7 x 0.1	AcCuAg	0.3	0.84	PTFE	1.3	CuAg	2.0	PTFE	
1	RG-174A/U	50±2	7 x 0.16	AcCu	0.48	1.5	PE	2.0	CuSn	2.8	PVC	50-2-1 50-1-1 50-2-3 50-1-2 50-2-2 75-2-1
	RG-174/U	50±2	7 x 0.16	AcCu	0.48	1.5	PE	2.0	CuSn	2.6	PVC	
	RG-178B/U	50±2	7 x 0.1	AcCuAg	0.3	0.84	PTFE	1.3	CuAg	1.8	FEP	
	RG-188A/U	50±2	7 x 0.18	AcCuAg	0.54	1.5	PTFE	2.0	CuAg	2.6	FEP	
	RG-196A/U	50±2	7 x 0.1	AcCuAg	0.3	0.84	PTFE	1.3	CuAg	2.0	PTFE	
	RG-316/U	50±2	7 x 0.18	AcCuAg	0.54	1.5	PTFE	2.0	CuAg	2.5	FEP	
	RG-179B/U	75±3	7 x 0.1	AcCuAg	0.3	1.5	PTFE	2.0	CuAg	2.6	FEP	
	LiYCY 1 x 0.14 mm ² LifYCY 1 x 0.04 mm ²	¹⁾ ²⁾	18 x 0.1 20 x 0.05	CuSn CuSn	0.5 0.4	1.1 0.8	PVC PVC	1.6 1.3	CuSn CuSn	2.4 1.6	PVC PVC	
2	RG-180B/U	95±5	7 x 0.1	AcCuAg	0.3	2.6	PTFE	3.1	CuAg	3.6	FEP	Belden(USA)
	BELDEN 8218	75±3	7 x 0.14	AcCu	0.43	2.54	PE	3.0	CuSn	3.81	PVC	
3	RG-122/U	50±2	27 x 0.13	CuSn	0.8	2.5	PE	3.2	CuSn	4.1	PVC	
	LiYCY 1 x 0.25 mm ²	¹⁾	14 x 0.15	CuSn	0.66	1.3	PVC	1.8	CuSn	2.6	PVC	
	LiYCY 1 x 0.38 mm ²	²⁾	19 x 0.16	CuSn	0.8	1.4	PVC	2.0	CuSn	2.9	PVC	
4	RG-58C/U	50±2	19 x 0.18	CuSn	0.9	2.95	PE	3.6	CuSn	5.0	PVC	50-3-1 50-3-7
	RG-141A/U	50±2	1 x 0.95	AcCuAg	0.95	2.95	PTFE	3.6	CuAg	4.8	PTFE	
	RG-142B/U	50±2	1 x 0.95	AcCuAg	0.95	2.95	PTFE	4.3	2x CuAg	5.0	FEP	
	RG-303/U	50±2	1 x 0.95	AcCuAg	0.95	2.95	PTFE	3.6	CuAg	4.3	FEP	
	RG-400/U	50±2	19 x 0.2	CuAg	1.0	2.95	PTFE	4.3	2x CuAg	5.0	FEP	
5	LiYCY 1 x 0.50 mm ²	¹⁾	16 x 0.2	CuSn	0.95	1.8	PVC	2.4	CuSn	3.1	PVC	
	LiYCY 1 x 0.75 mm ²	¹⁾	24 x 0.2	CuSn	1.2	2.0	PVC	2.6	CuSn	3.2	PVC	
	LifYCY 1 x 0.50 mm ²	²⁾	256 x 0.05	CuSn	1.0	2.0	PVC	2.6	CuSn	3.2	PVC	
	LifYCY 1 x 0.75 mm ²	²⁾	384 x 0.05	CuSn	1.2	2.2	PVC	2.8	CuSn	3.6	PVC	
6	RG-59B/U	75±3	1 x 0.6	AcCu	0.6	3.7	PE	4.5	Cu	6.1	PVC	50-3-5 75-4-6
	RG-223/U	50±2	1 x 0.89	CuAg	0.89	2.95	PE	4.2	2x CuAg	5.4	PVC	
	RG-302/U	75±3	1 x 0.64	AcCuAg	0.64	3.7	PTFE	4.4	CuAg	5.1	FEP	

¹⁾ Insulated, stranded wires with screen and jacket, standardized by the German VDE 0812, for low frequency applications when no defined impedance is required.

²⁾ Insulated, highly flexible stranded wires with screen and jacket, for low frequency applications when no defined impedance is required.

Legend

Cu Plain copper wire
 CuAg Silver plated copper wire
 CuSn Tin plated copper wire
 StCu Copper-clad steel wire
 StCuAg Copper-clad steel wire, silver plated

FEP Fluorethylenepropylene
 FPE Foam polyethylene
 PE Polyethylene
 PTFE Polytetrafluorethylene
 PVC Polyvinyl chloride

CSM Hypalon® (DuPont)

COAX LOW & HIGH VOLTAGE

FOR COAX, TRIAX & MIXED COAX CONNECTORS

Gr. No	Designation US MIL-C-17	Impedance ohms	Center conductor		Dielectric			Cable screen		Cable jacket		IEC publication 60096-2 or manufacturer
			Construction	ø [mm]	ø [mm]	Material	ø [mm]	Material	ø [mm]	Material		
7	RG-212/U	50±2	1 x 1.35	CuAg	1.35	4.7	PE	6.2	2x CuAg	8.5	PVC	Suhner (CH)
	RG-222/U	50±2	1 x 1.37	CrNi	1.37	4.7	PE	6.2	2x CuAg	8.5	PVC	
	SUHNER G 05232	50±2	7 x 0.5	Cu	1.5	4.8	PE	5.6	Cu	7.4	PVC	
	RG-6A/U	75±3	1 x 0.73	AcCu	0.73	4.7	PE	6.2	CuAg	8.5	PVC	
8	RG-115A/U	50±2	7 x 0.75	CuAg	2.25	6.5	PTFE	8.0	2 x CuAg	10.5	PTFE	50-7-8 50-7-1 75-7-1
	RG-165/U	50±2	7 x 0.82	CuAg	2.46	7.25	PTFE	8.0	CuAg	10.4	PTFE	
	RG-213/U	50±2	7 x 0.75	Cu	2.25	7.25	PE	8.2	Cu	10.3	PVC	
	RG-11A/U	75±3	7 x 0.4	CuSn	1.2	7.25	PTFE	8.2	Cu	10.3	PVC	
9	RG-214/U	50±2	7 x 0.75	CuAg	2.25	7.25	PE	8.7	2 x CuAg	10.8	PVC	
	RG-217/U	50±2	1 x 2.7	Cu	2.7	9.4	PE	11.2	2 x Cu	13.8	PVC	
	RG-280/U	50±2	1 x 2.9	Cu	2.9	8.3	PTFE	9.8	2 x CuAg	12.2	PVC	
	RG-12A/U	75±3	RG-11A/U	armoured with zinc plated steel braid			11.8	FeZn	14.0	PVC		
	RG-34B/U	75±3	7 x 0.62	Cu	1.86	11.5	PE	12.4	Cu	16.0	PVC	
10	RG-177/U	50±2	1 x 5.0	Cu	5.0	17.3	PE	18.8	2x CuAg	22.7	PVC	50-17-1 75-17-1
	RG-218/U	50±2	1 x 5.0	Cu	5.0	17.3	PE	18.6	Cu	22.1	PVC	
	RG-164/U	75±3	1 x 2.65	Cu	2.65	17.3	PE	18.6	Cu	22.1	PVC	
11	RG-403/U Triaxial	50±2	7 x 0.1	AcCuAg	2. screen and jacket :			1.3	CuAg	1.9	FEP	Habia (UK)
	RG-178 Type Triax	50±2	7 x 0.1	AcCuAg	2. screen and jacket :			2.4	CuAg	3.1	FEP	Filotex (F)
	SUHNER G 02332 Triaxial	50±2	7 x 0.15	Cu	2. screen and jacket :			1.8	CuAg	2.6	FEP	Suhner (CH)
								2.9	CuAg	3.6	FEP	
12	BELDEN 9222 RG-58 Type Triax	50±2	7 x 0.32	CuSn	2. screen and jacket :			2.0	Cu	2.55	PVC	Belden (USA)
								3.0	Cu	4.25	PVC	

COAX
LOW & HIGH
VOLTAGE

COAX LOW & HIGH VOLTAGE, TRIAX & MIXED COAX & MIXED HIGH VOLTAGE

1	Housing color Which housing color do you need?	NATURAL CHROME without guide mark	BLACK CHROME without guide mark
2	Contact block material	PTFE	PTFE
3	Contact type	Solder	Solder
4	Keying code None	-600	-700

CONTACT TYPES FOR PANEL MOUNTED CONNECTORS

Applicable for	Last digit	Description
Front mounted: D - DEU/E - DB - DBEU/E - DG - SF - SFU/E	0	Solder contacts
Rear mounted: DBP - DBPU/E - DBPLU/E - DGP - SFPU/E	9	Solder contacts

DESIGN AND ACCESSORIES

Applicable for	Extensions	Description
Receptacles	N	Nickel plated body with bright finish
	E	EPDM interface O-ring
	G	Ground tag
	B	Black nut
	D	Decorative slotted nut
	F	Decorative nut (with 2 flats)

Other options are available on request, please contact us.

EXAMPLES

Plugs

SV 103 A002-600 Ø6.7

Natural chrome housing color with PTFE contact block, solder contacts and cable clamp set (diameter 6.7 mm)

S 104 A060-600 Ø3.4-UI

Natural chrome housing color with PTFE contact block, solder contacts and insulating clamp set (diameter 3.4 mm)

Receptacles

DBPLE 102 A002 - 709EGD

Black chrome housing color with PTFE contact block, solder contacts, EPDM interface O-ring, ground tag and decorative slotted nut

DKBE 103 A026 - 600 Ø6.2E

Natural chrome housing color with PTFE contact block, solder contacts, cable clamp set (diameter 6.2 mm) and EPDM interface O-ring

B3-28 / B3-34

COAX
HIGH VOLTAGE

PLUGS



CABLE MOUNTED

- Body styles (S; SE; SV; SVE)..... B3-29
- Technical dimensions B3-30

RECEPTACLES



PANEL MOUNTED

- Body styles (D; DEE) B3-31
- Technical dimensions B3-32

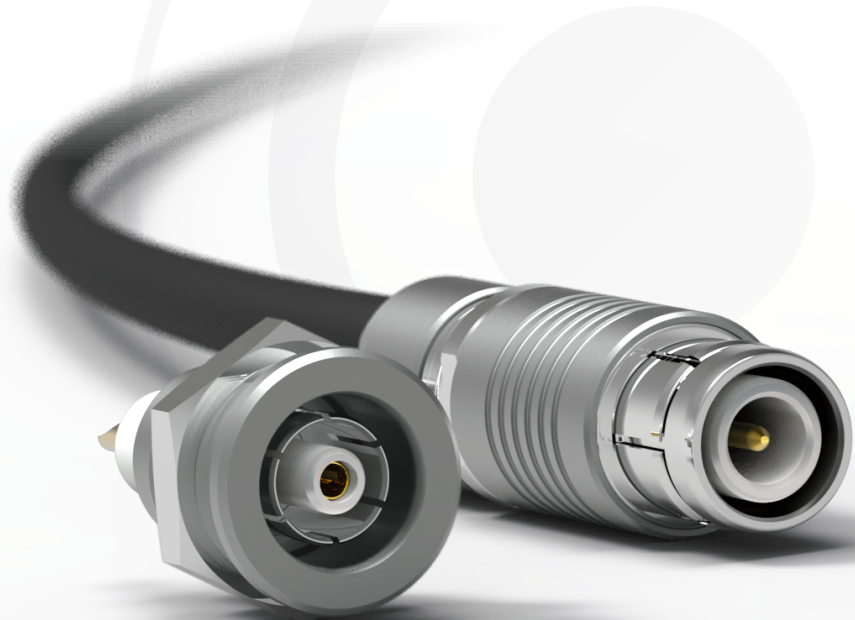

FOR ALL COAX HIGH VOLTAGE

- Electrical & contact configurations..... B3-34
- Cable groups B3-24
- Options B3-26
- Cable clamp sets included in product B2-39
- Accessories B6-2
- Tooling B6-19
- Technical information..... B1-13
- Product specifications A-5

This catalog covers our standard connector solutions. For specific requests, including hybrid or custom connectors, please contact your local sales representative.

PLUGS

CABLE MOUNTED



Body style		S	SE ¹⁾	SV	SVE ¹⁾	References to detailed information
Protection	Unsealed (IP50)	●		●		Sealing categories, page A-6
	Sealed up to IP68		●		●	
Locking system	None					Locking systems, page A-5
	Push-pull	●	●	●	●	
	Quick-release					
	Lanyard					
	Tamperproof			●	●	
Contacts	Crimp					Electrical & contact configurations, page B 3-34
	Solder	●	●	●	●	
Housing color	Natural chrome	●	●	●	●	Options, page B3-26
	Black chrome	●	●			
Design	Shortened body					Body styles, page B 1-2
	Right-angle					
Cabling	Cable clamp sets	●	●	●	●	Cable clamp set included in product, page B2-39
	Overmoldable					
	Heat shrinkable					
Accessories	Cable bend reliefs	●	●	●	●	Accessories, page B6-2
	Protective sleeves	●	●			
	Sealing caps	●	●	●	●	
Size	102 Series	●	●	●	●	Technical dimensions, page B3-30
	103 Series	●	●	●	●	
	1031 Series					
	104 Series	●	●	●	●	
	105 Series	●	●	●	●	
	106 Series					
	107 Series	●	●	●	●	For more information visit: www.fischerconnectors.com/technical

¹⁾ Environmental cable clamp set included.

PLUGS

CABLE MOUNTED

S/SE

BODY STYLES

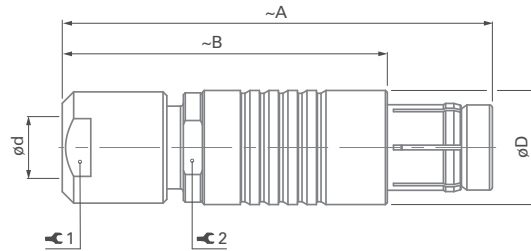

SV/SVE

BODY STYLES

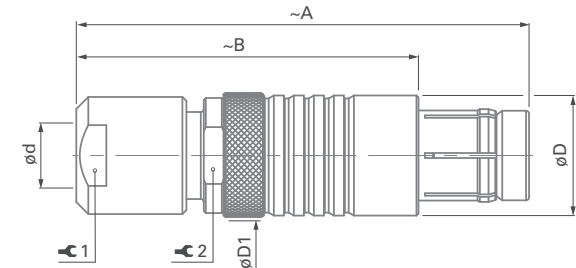

FOR S/SE & SV/SVE

Type	A	B	D	D1	Dmax		⚗ ₁	Torque 1 [Nm]	⚗ ₂
					Unsealed	Sealed			
102 ^A / _Z 018	36	26	9	11	4.7	4.3	7	0.6	7
102 ^A / _Z 025	60	46	9	-	5.2	-	Crimping tool and dies ¹⁾ TX00.241 & TX00.251		
103 ^A / _Z 023	46	35	12	13	6.7	6.2	10	1.0	10
104 ^A / _Z 010	50	38	15	20	8.7	8.7	12	2.0	13
105 ^A / _Z 004	62	47	18	22	10.7	10.7	15	3.5	16
105 ^A / _Z 005	62	47	18	22	10.7	10.7	15	3.5	16

¹⁾ Cable screen and jacket (e.g. RG-58) are retained by hex-crimp to the plug shell.

²⁾ For improved safety, the center contact is further recessed than in the S 105 A049.

³⁾ Two wrenches with an opening of 32 mm are required for SV/SVE 107 series.

⁴⁾ For insertion of center contact which has to be assembled after wiring, we recommend tool TP00.000, as shown on the Tooling section, page B 6-24.

Type	A	B	D	D1	Dmax		⚗ ₁	Torque 1 [Nm]	⚗ ₂
					Unsealed	Sealed			
105 ^A / _Z ⁴⁾ 049	90	60	18	22	10.7	10.7	15	3.5	16
105 A 108 ²⁾	100	60	18	-	10.7	-	15	3.5	16
107 ^A / _Z 003	110	85	34	38	22.7	-	32	10	32
107 A 004	137	112	34	38	22.7	-	30	10	32
107 ^A / _Z 017	137	112	34	38	22.7	22.7	30 ³⁾	10	32

Suitable Coax cables are indicated in the column "Cable Group" in Electrical & Contact specifications. The cable specifications are listed on page B3-24. If required, we will supply adapter sleeves which must be placed over the cable dielectric during assembly in order to guarantee proper performance. For cable clamps sets see page B 2-39. For non-sealed Coax connectors, the collet diameter has to be selected from the tables of type "S-Shielded", and for sealed Coax connectors from the tables of type "Environmental".

Torque [Nm] are recommended values that may be influenced by the characteristics of the cable jacket. Tests have to be made to evaluate the exact values. To secure the cable clamp nut, we recommend the use of thread locking adhesive.

RECEPTACLES

PANEL MOUNTED



Body style		D	DEE	References to detailed information
Protection	Unsealed (IP50)	●		Sealing categories, page A-6
	Sealed up to IP68		●	
	Hermetic		●	
Contacts	Crimp			Electrical & contact configurations, page B3-34
	Solder	●	●	
	PCB			
Housing color	Natural chrome	●	●	Options, page B3-26
	Black chrome	●	●	
Design	Right-angle			Body styles, page B 1-3
	Flush	●	●	
	Front-projecting			
	Bulkhead feedthrough			
Assembly	Front-mounting	●	●	
	Rear-mounting			
Accessories	Sealing caps	●	●	Accessories, page B6-2
	Spacers		●	
	Color-coded washers	●		
	Grounding washers	●	●	
	Locking washers	●	●	
Size	102 Series	●	●	Technical dimensions, page B3-32
	103 Series	●	●	
	1031 Series			
	104 Series	●	●	
	105 Series	●	●	
	106 Series			
	107 Series	●	●	
				For more information visit: www.fischerconnectors.com/technical

COAX
LOW & HIGH
VOLTAGE

RECEPTACLES

PANEL MOUNTED

D

BODY STYLE

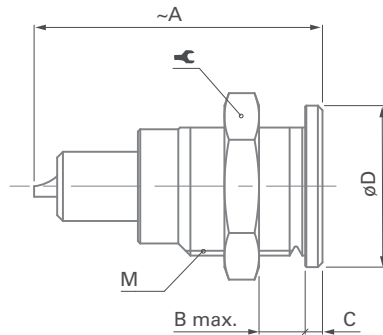

Types	A	B max.	C	D	M	⌘	Torque [Nm]
102 $\frac{A}{Z}$ 018	24	8	1.5	11	9x0.5	11	1.3
102 $\frac{A}{Z}$ 025	45	7	2.0	11	9x0.5	11	1.3
103 $\frac{A}{Z}$ 023	27	7	1.5	14	12x1	14	2.5
104 $\frac{A}{Z}$ 010	35	10	2.5	19	15x1	17	4.0
105 $\frac{A}{Z}$ 004	46	15	2.0	22	18x1	22	6.0
105 $\frac{A}{Z}$ 005 ¹⁾	46	15	2.0	22	18x1	22	6.0

Types	A	B max.	C	D	M	⌘	Torque [Nm]
105 $\frac{A}{Z}$ 049 ¹⁾	63 68	13	2.0	22	18x1	22	6.0
105 A 108 ²⁾	59	13	2.0	22	18x1	22	6.0
107 $\frac{A}{Z}$ 003	72	18	4.0	40	35x1	TX00.107	16
107 A 004	89	18	4.0	40	35x1	TX00.107	16
107 $\frac{A}{Z}$ 017	89	18	4.0	40	35x1	TX00.107	16

¹⁾ Also available with an optional micro switch.

²⁾ For insertion of center contact which has to be assembled after wiring we recommend tool TP00.000, as shown on the Tooling section, page B6-24.

RECEPTACLES

PANEL MOUNTED

DEE

BODY STYLE

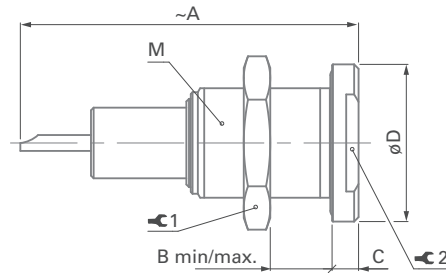
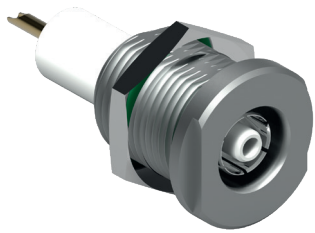

Types	A	B min/max.	C	D	M	⌘ ₁	Torque 1 [Nm]	⌘ ₂
102 $\frac{A}{Z}$ 018	26	8/12	2	14	9x0.5	11	1.3	11
102 $\frac{A}{Z}$ 025 ¹⁾	45	0.5/7	2	15	11x0.75	14	2.0	-
103 $\frac{A}{Z}$ 023	39 38	0/12	3	18	14x1	17	3.0	14
104 $\frac{A}{Z}$ 010	41 40	0/15	4	22	16x1	19	4.5	17

¹⁾ Non standard dimension of panel cut-out: ø11.1

²⁾ Also available with an optional micro switch.

Types	A	B min/max.	C	D	M	⌘ ₁	Torque 1 [Nm]	⌘ ₂
105 $\frac{A}{Z}$ 005 ²⁾	46 50	10.5/18	4	27	20x1	25	6.5	-
105 $\frac{A}{Z}$ 049 ²⁾	72 74	10.5/30	4	27	20x1	25	6.5	-
107 $\frac{A}{Z}$ 003	73	19.2/22	5	45	35x1	TX00.107	16	-
107 $\frac{A}{Z}$ 017	90 95	19.2/22	5	45	35x1	TX00.107	16	-

Receptacles of 106 and 107 series are supplied with slotted nuts.
For wrenches see Tooling section page B 6-19.

Torque [Nm] are recommended values that may be influenced by the quality of the panel surface. Tests have to be made to evaluate the exact values.

All dimensions and images shown are in millimeters and are for reference only.

102, 103, 104, 105 & 107 SERIES

● = Standard ○ = Option

Reference	Pin layout	Contact types		Insulating material ⁷⁾	Cable group ¹⁾	Contact ø [mm]	Wire barrel ø [mm]	Impedance [ohms]	Test voltage ⁶⁾ [kV] in mated position				Current ²⁾ [A]
		Solder	Crimp						AC r.m.s		DC		
									Contact to body	Contact to contact	Contact to body	Contact to contact	
102 A Z 018		●		PTFE	1/2	0.9	0.8	-	5.0	-	8.0	-	10
102 A Z 025		●	● ³⁾	PTFE	4	0.9	0.8	50	7.0	-	11	-	10
103 A Z 023		●		PTFE	4/6	1.3	1.2	50	6.0	-	10	-	12
104 A Z 010		●		PTFE	4/5/6/7	2.0	1.9	-	7.0	-	10	-	13
105 A Z 004		●		PTFE	5/7/8	4.0	3.0	40	9.0	-	13	-	32
105 A Z 005 ⁵⁾		● ○		PTFE PEEK	4/6/7	2.0	2.1	75	9.0	-	14	-	20
105 A Z 049 ⁵⁾		●		PTFE	4/6/7/8	2.0	2.3	-	11	-	19	-	35
105 A 108 ⁴⁾⁵⁾		●		PTFE	4/6/7/8	2.0	2.5	-	14	-	20	-	23
107 A Z 003		●		PTFE	7/8/9	4.0	2.8	75	14	-	25	-	45
107 A 004		●		PTFE	7/8/9	4.0	2.8	75	30	-	50	-	45
107 A Z 017		●		PTFE	7/8/9/10	5.0	5.1	50	30	-	50	-	60

¹⁾ See list of recommended cables on page B3-24.

²⁾ Current per contact at 40°C temperature rise measured on the basic curve according to IEC 60512-5-2-5b. For the max. operating current a reduction factor must be used and limitations due to the size of the wires and the permissible upper temperature limit of the materials employed must be taken into account. See page A-12 for details.

³⁾ Plug: center contact-crimp / Outer contact-crimp ferrule.
Receptacle: center contact-solder / Outer contact-washer with solder tag.

⁴⁾ Plug contains additionally recessed contacts.

⁵⁾ See Tooling section, page B6-23, for insertion tool of contact.

⁶⁾ Measured with S plug and D receptacle.

⁷⁾ PEEK is mainly used for hermetic connectors.

B4

CHAPTER



FISCHER CORE SERIES **BRASS**
TRIAx



TRIAx

B4-2 / B4-18

TRIAx

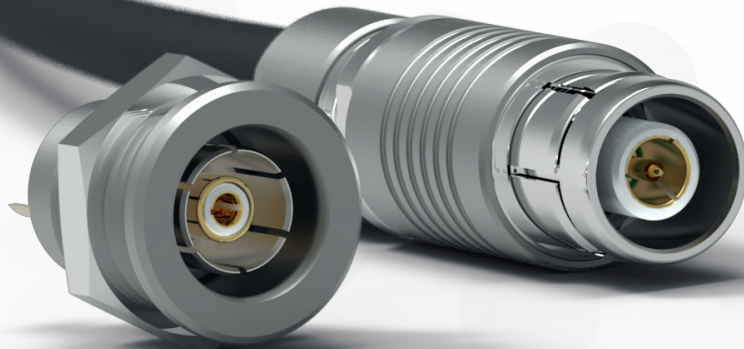

PLUGS



CABLE MOUNTED

- Body styles (S/SC; SOV; SA; SV; WSO) B4-3
- Technical dimensions B4-4



PANEL MOUNTED

- Body styles (SF; SFU; SFE) B4-13
- Technical dimensions B4-14

RECEPTACLES



CABLE MOUNTED

- Body styles (K; KE) B4-7
- Technical dimensions B4-8



PANEL MOUNTED

- Body styles (D; DEU; DEE; DB; DBEU; DBEE; DG) B4-9
- Technical dimensions B4-10



PANEL MOUNTED CABLE







- Body styles (DKBE; DK; DKE) B4-15
- Technical dimensions B4-16

FOR ALL TRIAX

- Electrical & contact configurations B4-18
- Cable designation B3-24
- Options B3-26
- Cable clamp sets B2-39
- Accessories B6-2
- Tooling B6-19
- Technical information B1-13
- Product specifications A-5

This catalog covers our standard connector solutions. For specific requests, including hybrid or custom connectors, please contact your local sales representative.

PLUGS

CABLE MOUNTED								
Body style		S	SC	SOV	SA	SV	WSO	Links to detailed information
Protection	Unsealed (IP50)	●	●	●	●	●	●	Sealing categories, page A-6
	Sealed up to IP68	●	●	●	●	●	●	
Locking system	Friction			●				Locking systems, page A-5
	Push-pull	●			●	●	●	
	Quick-release		●					
	Lanyard				●			
Contacts	Tamperproof					●		Electrical & contact configurations, page B 4-18
	Crimp							
Housing color	Solder	●	●	●	●	●	●	Options, page B3-26
	Natural chrome	●	●	●	●	●	●	
Design	Black chrome	●	●	●	●		●	Body styles, page B 1-2
	Shortened body						●	
Cabling	Right-angle						●	Cable clamp set, page B2-39
	Cable clamp sets	●	●	●	●	●	●	
	Overmoldable							
Accessories	Heat shrinkable							Accessories, page B6-2
	Cable bend reliefs	●	●	●	●	●	●	
	Protective sleeves	●	●	●				
Size	Sealing caps	●	●	●	●	●	●	Technical dimensions, page B4-4
	102 Series	●	●	●	●	●	●	
	103 Series	●	●	●	●	●	●	
	1031 Series							
	104 Series							
	105 Series							
	106 Series							
107 Series								
								For more information visit: www.fischerconnectors.com/technical



PLUGS

CABLE MOUNTED

S/SC

BODY STYLES

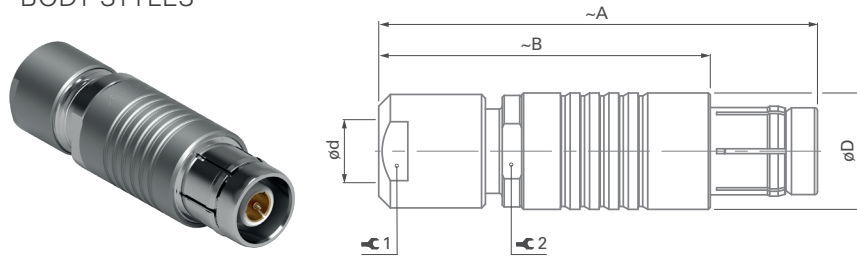

Series	A	B	D	d max		⚙️ 1	Torque 1 [Nm]	⚙️ 2
				Unsealed	Sealed			
102	36	26	9	4.7	4.3	7	0.6	7
103	46	35	12	6.7	6.2	10	1.0	10

SOV

BODY STYLE

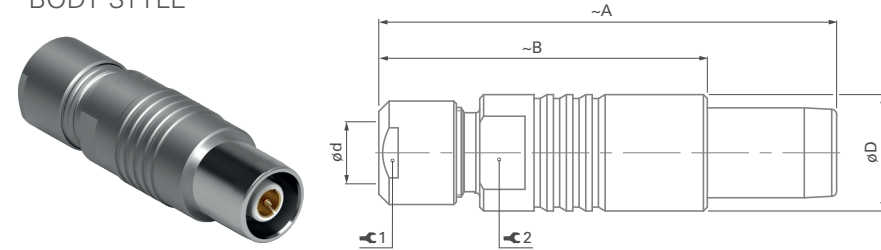

Series	A	B	D	d max		⚙️ 1	Torque 1 [Nm]	⚙️ 2
				Unsealed	Sealed			
102	36	26	9	4.7	4.3	7	0.6	7
103	46	35	12	6.7	6.2	10	1.0	10

PLUGS

CABLE MOUNTED

SA

BODY STYLE

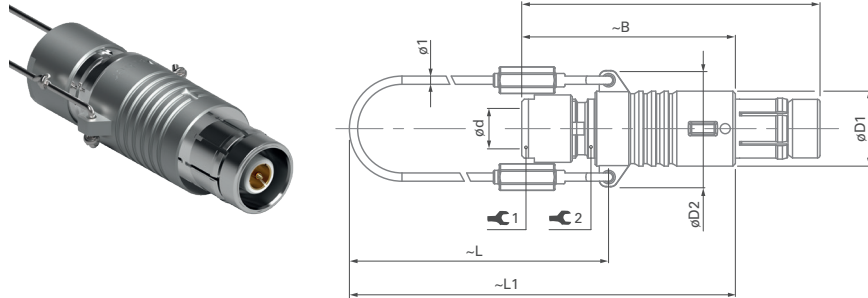

Series	A	B	D1	D2	L	L1	d max		1	Torque 1 [Nm]	2
							Unsealed	Sealed			
102	36	26	9	14	50	65	4.7	4.3	7	0.6	7
103	46	35	12	17	60	77	6.7	6.2	10	1.0	10

Torque [Nm] are recommended values that may be influenced by the characteristics of the cable jacket. Tests must be conducted to evaluate the exact values. To secure the cable clamp nut, we recommend the use of thread locking adhesive.

SV

BODY STYLE

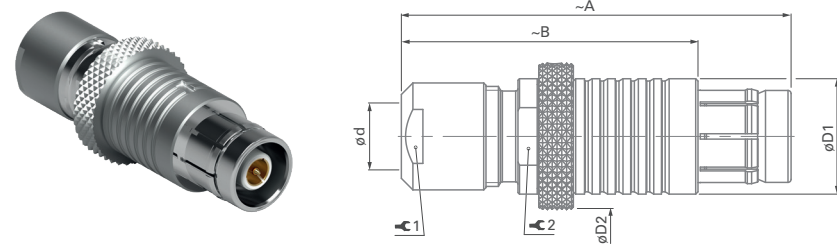

Series	A	B	D1	D2	d max		1	Torque 1 [Nm]	2
					Unsealed	Sealed			
102	36	26	9	11	4.7	4.3	7	0.6	-
103	46	35	12	13	6.7	6.2	10	1.0	-

PLUGS

CABLE MOUNTED

WSO

BODY STYLE

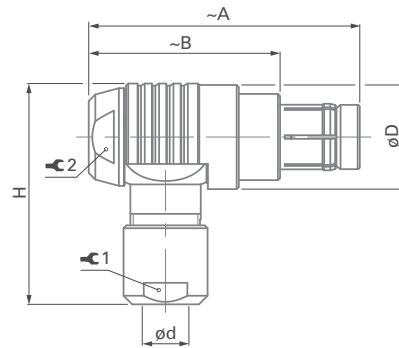

Series	A	B	D	H	d max		1	Torque 1 [Nm]	2	Torque 2 [Nm]
					Unsealed	Sealed				
102	33	23	12	25	4.7	4.3	7	0.6	8	1.0
103	38	27	15	31	6.7	6.2	10	1.0	11	1.3

RECEPTACLES

CABLE MOUNTED				
Body style		K	KE	References to detailed information
Protection	Unsealed (IP50)	●		Sealing categories, page A-6
	Sealed up to IP68		●	
Contacts	Crimp			Electrical & contact configurations, page B4-18
	Solder	●	●	
Housing	Natural chrome	●	●	Options, page B3-26
	Black chrome	●	●	
	Shortened body			
Cabling	Cable clamp sets	●	●	Cable clamp set, page B2-39
	Overmoldable			
	Heat shrinkable			
Accessories	Cable bend reliefs	●	●	Accessories, page B6-2
	Protective sleeves	●	●	
	Sealing caps	●	●	
Size	102 Series	●	●	Technical dimensions, page B4-8 For more information visit: www.fischerconnectors.com/technical
	103 Series	●	●	
	1031 Series			
	104 Series			
	105 Series			
	106 Series			
	107 Series			

All dimensions and images shown are in millimeters and are for reference only.

RECEPTACLES

CABLE MOUNTED

K/KE

BODY STYLES

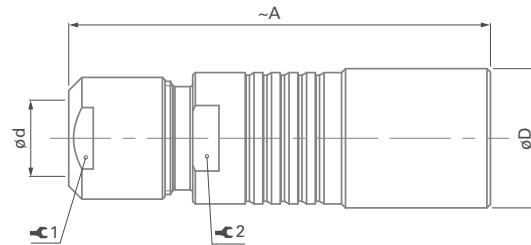

Series	A	D	d max		1	Torque 1 [Nm]	2
			Unsealed	Sealed			
102	35	10	4.7	4.3	7	0.6	7
103	43	13	6.7	6.2	10	1.0	10

Torque [Nm] are recommended values that may be influenced by the characteristics of the cable jacket. Tests must be conducted to evaluate the exact values. To secure the cable clamp nut, we recommend the use of thread locking adhesive.

RECEPTACLES

PANEL MOUNTED



Body style		D	DEU	DEE	DB	DBEU	DBEE	DG	References to detailed information
Protection	Unsealed (IP50)	●			●			●	Sealing categories, page A-6
	Sealed up to IP68		●	●		●	●		
	Hermetic			●			●		
Contacts	Crimp								Electrical & contact configurations, page B4-18
	Solder	●	●	●	●	●	●	●	
	PCB								
Housing color	Natural chrome	●	●	●	●	●	●	●	Options, page B3-26
	Black chrome	●	●	●	●	●	●	●	
Design	Right-angle								Body styles, page B 1-3
	Flush	●	●	●				●	
	Front projecting				●	●	●	●	
	Bulkhead feedthrough								
Assembly	Front-mounting	●	●	●	●	●	●	●	
	Rear-mounting							●	
Accessories	Sealing caps	●	●	●	●	●	●	●	Accessories, page B 6-2
	Spacers		●	●					
	Color-coded washers	●			●			●	
	Insulating washers	●	●	●	●	●	●	●	
	Grounding washers	●	●	●	●	●	●	●	
	Locking washers	●	●	●	●	●	●	●	
Size	102 Series	●	●	●	●	●	●	●	Technical dimensions, page B4-10 For more information visit: www.fischerconnectors.com/technical
	103 Series	●	●	●	●	●	●	●	
	1031 Series								
	104 Series								
	105 Series								
	106 Series								
	107 Series								

RECEPTACLES

PANEL MOUNTED

D

BODY STYLE

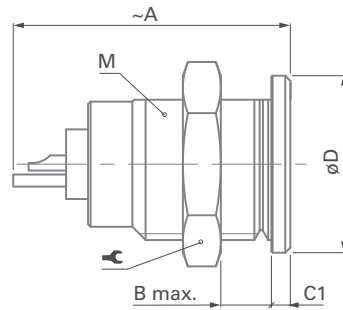

Series	A	B _{max}	C1	D	M	⚗	Torque [Nm]
102	19	9	1.5	11	9x0.5	11	1.3
103	23	8	1.5	14	12x1	14	2.5

DEU/DEE

BODY STYLES

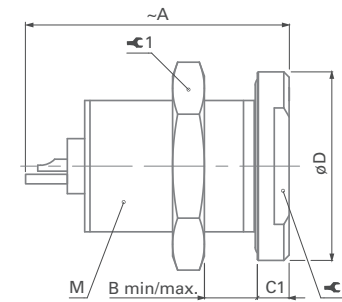

Series	A	B _{min/max}	C1	D	M	⚗ ₁	Torque ₁ [Nm]	⚗ ₂
102	20	8/10	2.5	14	9x0.5	11	1.3	11 ¹⁾
103	23	0/12	3.0	18	14x1	17	3.0	14

¹⁾Not applicable for 102 A021.

RECEPTACLES

PANEL MOUNTED

DB
BODY STYLE

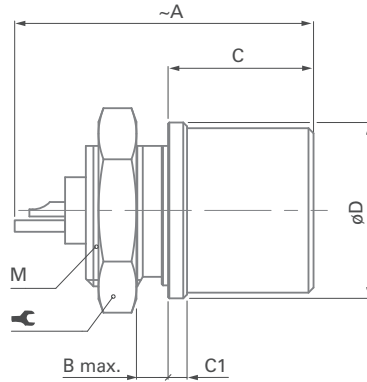

Series	A	B max.	C	C1	D	M	⌘	Torque [Nm]
102	18	3	11.0	1.0	11	9x0.5	11	1.3
103	21	4	11.5	1.5	14	12x1	14	2.5

Torque [Nm] are recommended values that may be influenced by the quality of the panel surface. Tests must be conducted to evaluate the exact values.

DBEU/DBEE
BODY STYLES

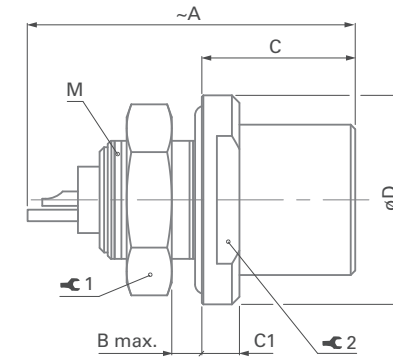
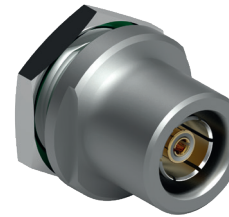

Series	A	B max.	C	C1	D	M	⌘ 1	Torque 1 [Nm]	⌘ 2
102	20	3.5	10.2	2.5	14	9x0.5	11	1.3	11
103	23	4.0	13.0	3.0	18	14x1	17	3.0	14

RECEPTACLES

PANEL MOUNTED

DG

BODY STYLE

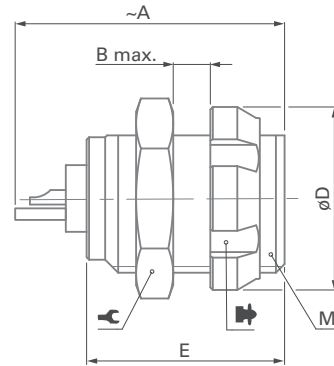
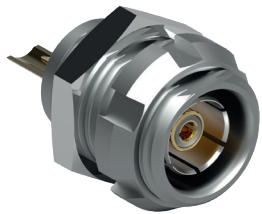

Series	A	B max.	D	E	M			Torque [Nm]
102	20	6	12	14	9x0.5	11	TC00.000	1.3
103	23	7	15	15	12x1	14	TF00.001	2.5

PLUGS

PANEL MOUNTED

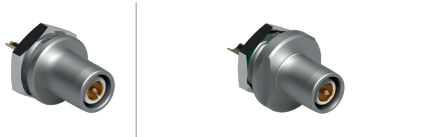

Body style		SF	SFU	SFE	References to detailed information
Protection	Unsealed (IP50)	●			Sealing categories, page A-6
	Sealed up to IP68		●	●	
	Hermetic			●	
Contacts	Crimp				Electrical & contact configurations, page B4-18
	Solder	●	●	●	
	PCB				
Housing color	Natural chrome	●	●	●	Options, page B3-26
	Black chrome	●	●	●	
Assembly	Front-mounting	●	●	●	Body styles, page B 1-2
	Rear-mounting				
Accessories	Sealing caps	●	●	●	Accessories, page B 6-2
	Spacers				
	Color-coded washers	●			
	Insulating washers	●			
	Grounding washers	●			
Size	Locking washers	●			Technical dimensions, page B4-14 For more information visit: www.fischerconnectors.com/technical
	102 Series	●	●	●	
	103 Series	●	●	●	
	1031 Series				
	104 Series				
	105 Series				
106 Series					
107 Series					

All dimensions and images shown are in millimeters and are for reference only.

PLUGS

PANEL MOUNTED

SF
BODY STYLE

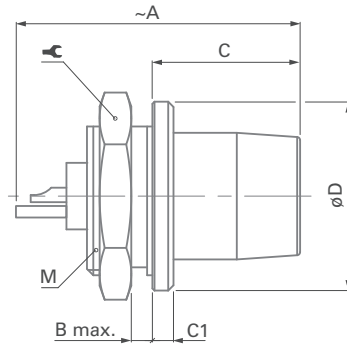
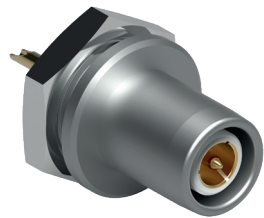

SFU/SFE
BODY STYLES

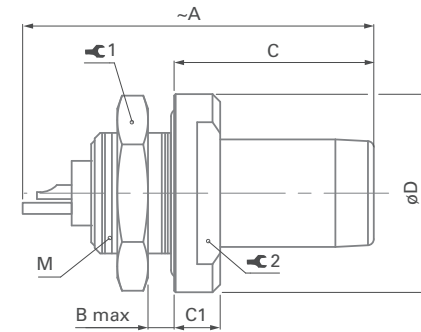
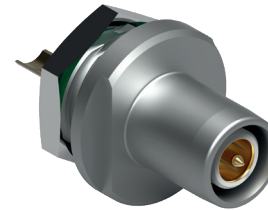



Series	A	B max.	C	C1	D	M	⌘	Torque [Nm]
102	20.0	4.0	11.0	1.0	10	9x0.5	11	1.3
103	23.5	3.0	12.5	1.5	14	12x1	14	2.5

Series	A	B max.	C	C1	D	M	⌘ ₁	Torque 1 [Nm]	⌘ ₂
102	21	2.5	13	3	13	9x0.5	11	1.3	9
103	26	5.0	14	3	17	12x1	14	2.5	12

Torque [Nm] are recommended values that may be influenced by the quality of the panel surface. Tests must be conducted to evaluate the exact values.

RECEPTACLES

PANEL MOUNTED CABLE					
Body style		DKBE	DK	DKE	Links to detailed information
Protection	Unsealed (IP50)		●		Sealing categories, page A-6
	Sealed up to IP68	●		●	
Contacts	Crimp				Electrical & contact configurations, page B 4-18
	Solder	●	●	●	
Housing color	Natural chrome	●	●	●	Options, page B 3-26
	Black chrome	●	●	●	
Design	Flush		●		Body styles, page B 1-3
	Front-projecting	●		●	
Assembly	Panel mounted	●	●	●	
	Front-mounting		●	●	
	Rear-mounting	●			
	Cable mounted	●	●	●	
	Cable clamp sets	●	●	●	Cable clamp sets, page B 2-39
Accessories	Cable bend reliefs	●	●	●	Accessories, page B 6-2
	Sealing caps	●	●	●	
	Spacers			●	
	Color-coded washers	●	●		
	Insulating washers				
	Grounding washers	●	●	●	
Size	Locking washers	●	●	●	Technical dimensions, page B 4-16
	102 Series	●	●	●	
	103 Series	●	●	●	
	1031 Series				
	104 Series				
	105 Series				
	106 Series				
107 Series					
					For more information visit: www.fischerconnectors.com/technical

RECEPTACLES

PANEL MOUNTED CABLE

DKBE

BODY STYLE

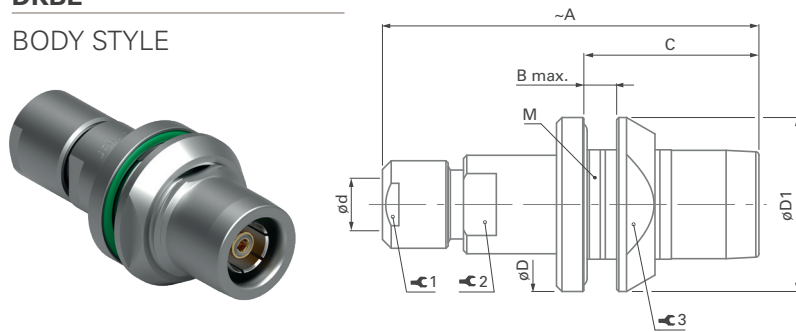

Series	A	B max.	C	D	dmax	D1	M
102	35	3.5	16.0	16	4.3	16	12x1
103	43	4.0	19.0	19	6.2	20	15x1

Series	1	Torque 1 [Nm]	2	3	Torque 3 [Nm]
102	7	0.6	7	13	2.5
103	10	1.0	10	17	4.0

DK

BODY STYLE

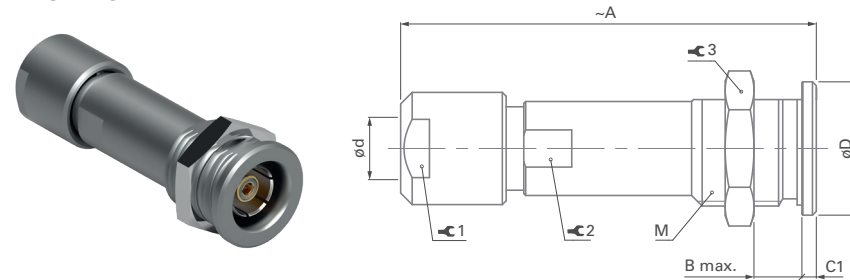

Series	A	B max.	C1	D	dmax	M
102	35	9	1.5	11	4.7	9x0.5
103	44	10	1.5	14	6.7	12x1

Series	1	Torque 1 [Nm]	2	3	Torque 3 [Nm]
102	7	0.6	-	11	1.3
103	10	1.0	9	14	2.5

RECEPTACLES

PANEL MOUNTED CABLE

DKE

BODY STYLE

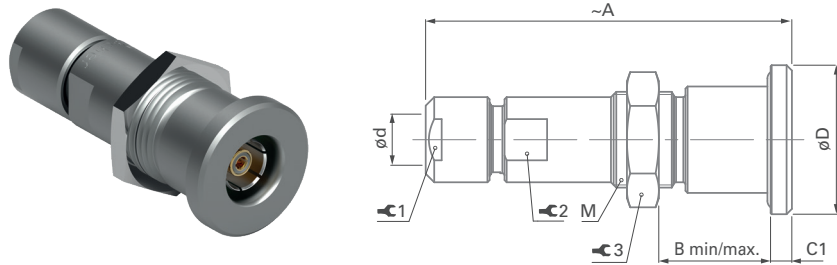

Series	A	B min/max.	C	C1	D	dmax	M	🔧 1	Torque 1 [Nm]	🔧 2	🔧 3	Torque 3 [Nm]
102	35	9/12	-	2	14	4.3	9x0.5	7	0.6	7	11	1.3
103	45	9/14	-	3	17	6.2	14x1	10	1.0	10	17	3.0

Torque [Nm] are recommended values that may be influenced by the characteristics of the cable jacket and the quality of the panel surface. Tests must be conducted to evaluate the exact values.

To secure the cable clamp nut, we recommend the use of thread locking adhesive.

102 & 103 SERIES

● = Standard ○ = Option

Reference	Pin layout	Contact type		Insulating material	Cable group ¹⁾	Contact ø [mm]	Wire barrel ø [mm]	Impedance [ohms]	Test voltage ³⁾ [kV] in mated position				Current ²⁾ [A]
		Solder	Crimp						AC r.m.s		DC		
									Contact to body	Contact to contact	Contact to body	Contact to contact	
102 A014		● ○		PTFE PEEK	11	0.9	0.8	-	1.1	1.2	1.5	1.7	10
102 A021 ⁴⁾		●		PTFE	11	0.9	0.8	50	1.2	1.0	1.7	1.5	10
103 A015		● ○		PTFE PEEK	12	1.3	1.0	50	1.2	1.5	1.6	2.4	12

¹⁾ See list of recommended cables on page B 3-24.

²⁾ Current per contact at 40°C temperature rise measured on the basic curve according to IEC 60512-5-2-5b. For the max. operating current a reduction factor must be used and limitations due to the size of the wires and the permissible upper temperature limit of the materials employed must be taken into account. See page A-12 for details.

³⁾ Measured with S plug and D receptacle. Please contact us for ratings for WSO right-angle plugs.

⁴⁾ Inverted polarity: female contact on plug/male contact on receptacle.

B5

CHAPTER

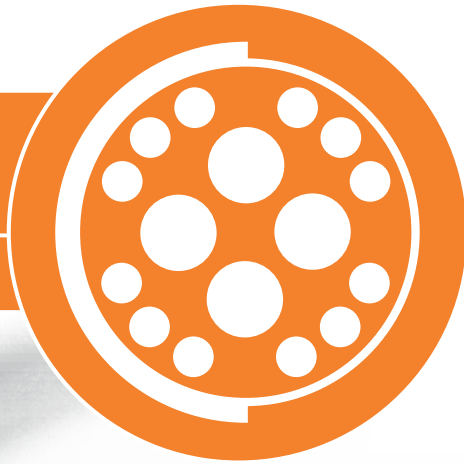

FISCHER CORE SERIES **BRASS** **MIXED**

- COAX.....B5-2
- HIGH VOLTAGE.....B5-18



MIXED
COAX & HIGH
VOLTAGE

B5-2 / B5-24

MIXED COAX



PLUGS



CABLE MOUNTED

- Body styles (S/SC; SOV; SA; SV) B5-3
- Technical dimensions B5-4



PANEL MOUNTED

- Body style selection (SF) B5-11
- Technical dimensions B5-12

RECEPTACLES



CABLE MOUNTED

- Body styles (K/KE) B5-6
- Technical dimensions B5-7



PANEL MOUNTED

- Body styles (D; DB; DG) B5-8
- Technical dimensions B5-9



PANEL MOUNTED CABLE





- Body styles (DKBE; DK; DKE) B5-13
- Technical dimensions B5-14

FOR ALL MIXED COAX

- Electrical & contact configurations B5-16
- Cable designation B3-24
- Options B3-26
- Insulating cable clamp sets B2-59
- Accessories B6-2
- Tooling B6-19
- Technical information B1-13
- Product specifications A-5

This catalog covers our standard connector solutions. For specific requests, including hybrid or custom connectors, please contact your local sales representative.

PLUGS

CABLE MOUNTED							
Body style		S	SC	SOV	SA	SV	Links to detailed information
Protection	Unsealed (IP50)	●	●	●	●	●	Sealing categories, page A-6
	Sealed up to IP68	●	●	●	●	●	
Locking system	Friction			●			Locking systems, A-5
	Push-pull	●			●	●	
	Quick-release		●				
	Lanyard				●		
	Tamperproof					●	
Contacts	Crimp (coax)	●	●	●	●	●	Electrical & contact configurations, page B5-16
	Solder (others)	●	●	●	●	●	
Housing color	Natural chrome	●	●	●	●	●	Options, page B3-26
	Black chrome	●	●	●	●		
Design	Shortened body						Body styles, page B1-2
	Right angle						
Cabling	Cable clamp sets	●	●	●	●	●	Insulating cable clamp sets, page B2-59
	Overmoldable						
	Heat shrinkable						
Accessories	Cable bend reliefs	●	●	●	●	●	Accessories, page B6-2
	Protective sleeves	●	●	●	●	●	
	Sealing caps	●	●	●	●	●	
Size	102 Series						Technical dimensions, page B5-4 For more information visit: www.fischerconnectors.com/technical
	103 Series						
	1031 Series						
	104 Series	●	●	●	●	●	
	105 Series	●	●	●	●	●	
	106 Series						
	107 Series						

MIXED COAX & HIGH VOLTAGE

PLUGS

CABLE MOUNTED

S/SC

BODY STYLES

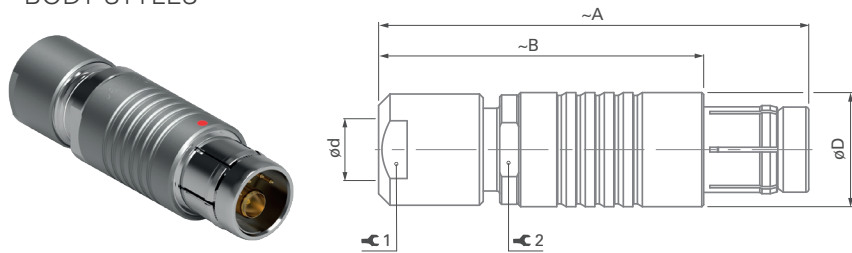

SOV

BODY STYLE

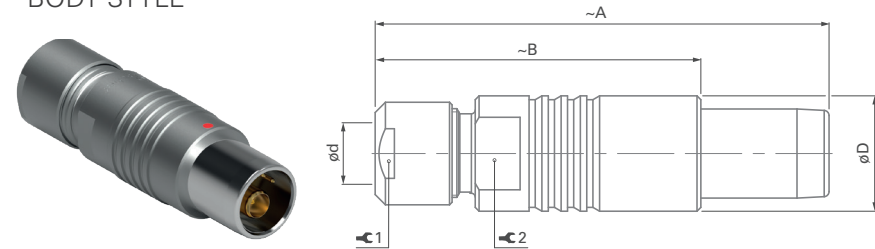

Series	A	B	D	d max		1	Torque 1 [Nm]	2
				Unsealed	Sealed			
104	50	38	15	8.7	8.7	12	2.0	13
105	62	47	18	10.7	10.7	15	3.5	16

Series	A	B	D	d max		1	Torque 1 [Nm]	2
				Unsealed	Sealed			
104	50	38	15	8.7	8.7	12	2.0	13
105	62	47	18	10.7	10.7	15	3.5	16

Torque [Nm] are recommended values that may be influenced by the characteristics of the cable jacket.

Tests must be conducted to evaluate the exact values. To secure the cable clamp nut, we recommend the use of thread locking adhesive.

MIXED COAX & HIGH VOLTAGE

PLUGS

CABLE
MOUNTED

SA

BODY STYLE

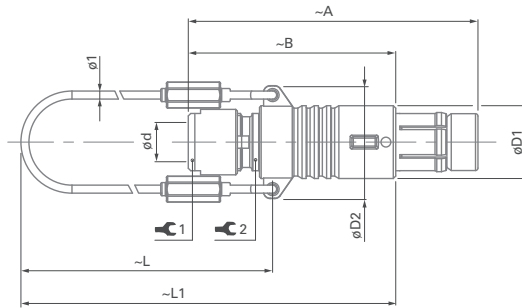

SV

BODY STYLE

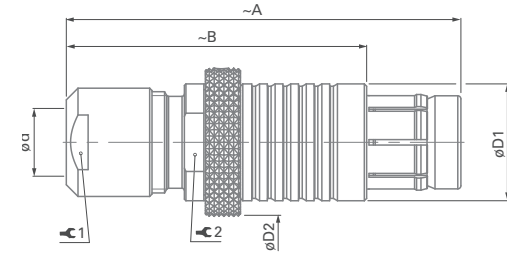

Series	A	B	D1	D2	L	L1	d max		⌘ 1	Torque 1 [Nm]	⌘ 2
							Unsealed	Sealed			
104	50	38	15	21	65	84	8.7	8.7	12	2.0	13
105	62	47	18	25	70	94	10.7	10.7	15	3.5	16

Series	A	B	D1	D2	d max		⌘ 1	Torque 1 [Nm]	⌘ 2
					Unsealed	Sealed			
104	50	38	15	20	8.7	8.7	12	2.0	13
105	62	47	18	22	10.7	10.7	15	3.5	16

All dimensions and images shown are in millimeters and are for reference only.

RECEPTACLES

CABLE MOUNTED



Body style		K	KE	Links to detailed information
Protection	Unsealed (IP50)	●		Sealing categories, page A-6
	Sealed up to IP68		●	
Contacts	Crimp (coax)	●	●	Electrical & contact configurations, page B5-16
	Solder (others)	●	●	
Housing	Natural chrome	●	●	Options, page B 3-26
	Black chrome	●	●	
	Shortened body			
Cabling	Cable clamp sets	●	●	Insulating cable clamp sets, page B 2-59
	Overmoldable			
	Heat shrinkable			
Accessories	Cable bend reliefs	●	●	Accessories, page B 6-2
	Protective sleeves	●	●	
	Sealing caps	●	●	
Size	102 Series			Technical dimensions, page B5-7 For more information visit: www.fischerconnectors.com/technical
	103 Series			
	1031 Series			
	104 Series	●	●	
	105 Series	●	●	
	106 Series			
	107 Series			

MIXED
COAX & HIGH
VOLTAGE

RECEPTACLES

CABLE MOUNTED

K/KE

BODY STYLES

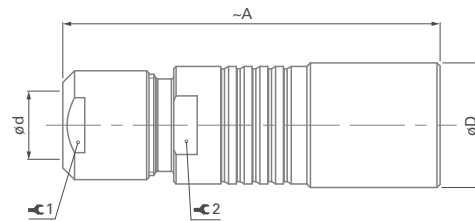

Series	A	D	d max		1	Torque 1 [Nm]	2
			Unsealed	Sealed			
104	50	16	8.7	8.7	12	2.5	13
105	60	19	10.7	10.7	15	3.5	16

Torque [Nm] are recommended values that may be influenced by the characteristics of the cable jacket. Tests must be conducted to evaluate the exact values. To secure the cable clamp nut, we recommend the use of thread locking adhesive.

RECEPTACLES

PANEL MOUNTED



MIXED COAX & HIGH VOLTAGE

Body style		D	DB	DG	Links to detailed information
Protection	Unsealed (IP50)	●	●	●	Sealing categories, page A-6
	Sealed up to IP68				
	Hermetic				
Contacts	Crimp (coax)	●	●	●	Electrical & contact configurations, page B5-16
	Solder (others)	●	●	●	
	PCB				
Housing color	Natural chrome	●	●	●	Options, page B3-26
	Black chrome	●	●	●	
Design	Right-angle				Body styles, page B1-3
	Flush	●		●	
	Front-projecting		●	●	
	Bulkhead feedthrough				
Assembly	Front-mounting	●	●	●	
	Rear-mounting			●	
Accessories	Sealing caps	●	●	●	Accessories, page B 6-2
	Spacers				
	Color-coded washers	●	●	●	
	Grounding washers	●	●	●	
	Locking washers	●	●	●	
Size	102 Series				Technical dimensions, page B5-9 For more information visit: www.fischerconnectors.com/technical
	103 Series				
	1031 Series				
	104 Series	●	●	●	
	105 Series	●		●	
	106 Series				
	107 Series				

RECEPTACLES

PANEL MOUNTED

D

BODY STYLE

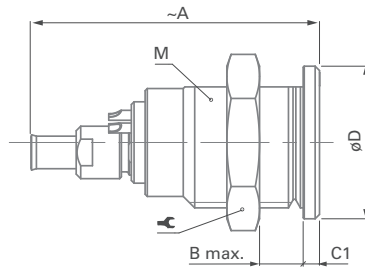



Series	A	B max.	C1	D	M		Torque [Nm]
104	33	11	2.2	19	15x1	17	4.0
105	38	15	2.0	22	18x1	22	6.0

Torque [Nm] are recommended values that may be influenced by the quality of the panel surface. Tests must be conducted to evaluate the exact values.

DB

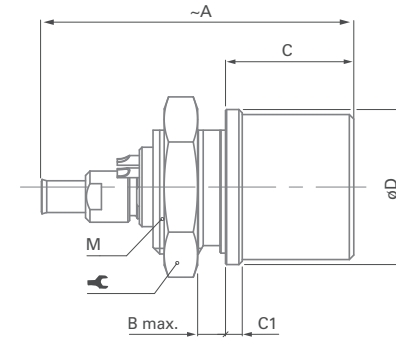
BODY STYLE



Series	A	B max.	C	C1	D	M		Torque [Nm]
104	33	3	14.5	2.5	19	16x1	19	4.5

RECEPTACLES

PANEL MOUNTED

DG

BODY STYLE

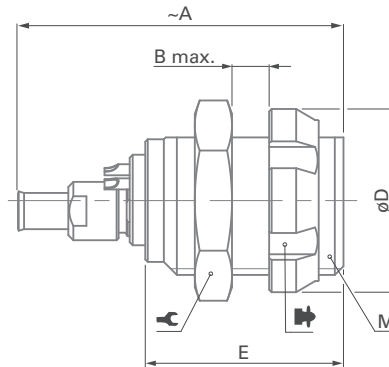

Series	A	B max.	D	E	M		 ¹⁾	Torque [Nm]
104	33	9	19	18	15x1	17	TK00.000	4.0
105	38	15	23	24	18x1	22	TP00.011	6.0

¹⁾ Assembly tool for decorative slotted nut, see Tooling section, page B 6-20 for details.

PLUGS

PANEL MOUNTED



Body style		SF	Links to detailed information
Protection	Unsealed (IP50)	●	Sealing categories, page A-6
	Sealed up to IP68		
	Hermetic		
Contacts	Crimp (coax)	●	Electrical & contact configurations, page B5-16
	Solder (others)	●	
	PCB		
Housing color	Natural chrome	●	Options, section B3-26
	Black chrome	●	
Assembly	Front-mounting	●	Body styles, page B1-2
	Rear-mounting		
Accessories	Sealing caps	●	Accessories, page B6-2
	Spacers		
	Color-coded washers	●	
	Insulating washers	●	
	Grounding washers	●	
	Locking washers	●	
Size	102 Series		Technical dimensions, page B5-12 For more information visit: www.fischerconnectors.com/technical
	103 Series		
	1031 Series		
	104 Series	●	
	105 Series	●	
	106 Series		
	107 Series		

MIXED
COAX & HIGH
VOLTAGE

PLUGS

PANEL MOUNTED

SF
BODY STYLE

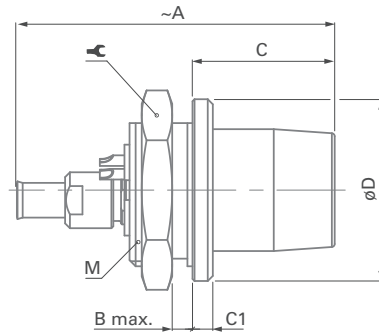



Series	A	B max.	C	C1	D	M		Torque [Nm]
104	28	3.0	14.0	2.0	18	15x1	17	4.0
105	35	5.5	16.8	1.2	22	16x1	19	4.5

Torque [Nm] are recommended values that may be influenced by the quality of the panel surface. Tests must be conducted to evaluate the exact values.

MIXED
COAX & HIGH
VOLTAGE

RECEPTACLES

PANEL MOUNTED CABLE					
Body style		DKBE	DK	DKE	References to detailed information
Protection	Unsealed (IP50)		●		Sealing categories, page A-6
	Sealed up to IP68	●		●	
Contacts	Crimp (coax)	●	●	●	Electrical & contact configurations, page B5-16
	Solder (others)	●	●	●	
Housing color	Natural chrome	●	●	●	Options, page B3-26
	Black chrome	●	●	●	
Design	Flush		●		Body styles, page B1-3
	Front-projecting	●		●	
Assembly	Panel mounted	●	●	●	
	Front-mounting		●	●	
	Rear-mounting	●			
	Cable mounted	●	●	●	
Cable clamp sets		●	●	●	Insulating cable clamp sets, page B2-59
Accessories	Cable bend reliefs	●	●	●	Accessories, page B6-2
	Sealing caps	●	●	●	
	Spacers			●	
	Color-coded washers	●	●	●	
	Insulating washers				
	Grounding washers	●	●	●	
Size	Locking washers	●	●	●	Technical dimensions, page B5-14
	102 Series				
	103 Series				
	1031 Series				
	104 Series	●	●	●	
	105 Series	●	●	●	
					For more information visit: www.fischerconnectors.com/technical

MIXED
COAX & HIGH
VOLTAGE

RECEPTACLES

PANEL MOUNTED CABLE

DKBE

BODY STYLE

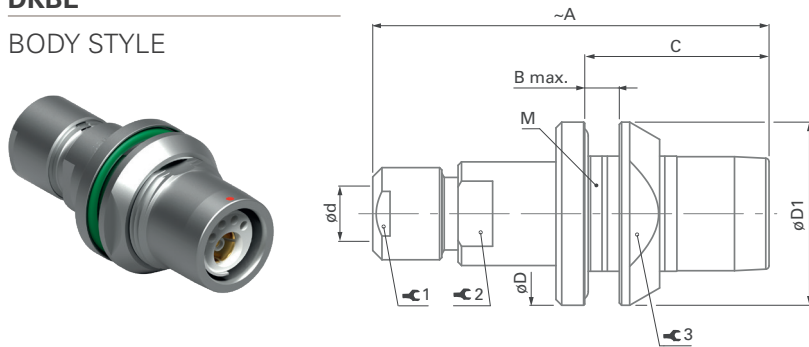

Series	A	B max.	C	D	dmax	D1	M
104	50	5.0	22.5	23	8.7	23	18x1
105	60	5.0	26.0	28	10.7	27	22x1

Series	1	Torque 1 [Nm]	2	3	Torque 3 [Nm]
104	12	2.0	13	20	6.0
105	15	3.5	16	24	8.0

DK

BODY STYLE

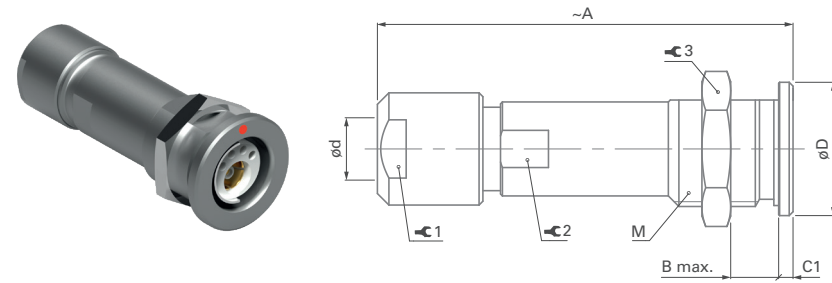

Series	A	B max.	C1	D	dmax	M
104	50	11	2.0	19	8.7	15x1
105	60	16	2.0	22	10.7	18x1

Series	1	Torque 1 [Nm]	2	3	Torque 3 [Nm]
104	12	2.0	12	17	4.0
105	15	3.5	14	22	6.0

MIXED COAX & HIGH VOLTAGE

RECEPTACLES

PANEL MOUNTED CABLE

DKE

BODY STYLE

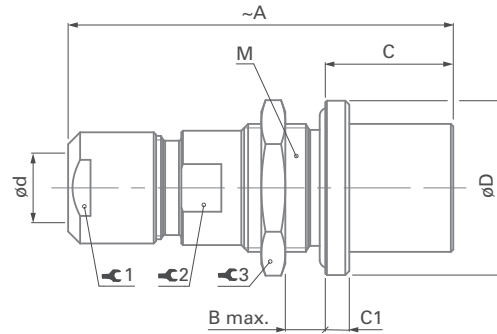

Series	A	B max.	C	C1	D	dmax	M	⚙️ 1	Torque 1 [Nm]	⚙️ 2	⚙️ 3	Torque 3 [Nm]
104	50	8	16.0	3	22	8.7	16x1	12	2.0	13	19	4.5
105	61	9	19.0	4	27	10.7	20x1	15	3.5	16	25	6.5

Torque [Nm] are recommended values that may be influenced by the characteristics of the cable jacket and by the quality of the panel surface. Tests must be conducted to evaluate the exact values. To secure the cable clamp nut, we recommend the use of thread locking adhesive.

104 & 105 SERIES

● = Standard ○ = Option

Reference	Pin layout	Number of contacts		Contact type		Insulating material	Cable group ¹⁾	Contact ø [mm]	Wire barrel ø [mm]	Impedance [ohm]	Test voltage ⁵⁾ [kV] in mated position				Current ³⁾ [A]
				Solder	Crimp						AC r.m.s		DC		
											Contact to body ²⁾	Contact to contact	Contact to body ²⁾	Contact to contact	
104 A 078		2	Coax		●	PEEK ⁴⁾	1	0.7	0.6	50	1.8	-	3.0	-	4.0
			1	●				0.9	0.8	-	0.8	-	1.6	-	9.0
104 A 093		5	Coax		●	PTFE	1	0.7	0.6	50	1.8	-	3.0	-	4.0
			4	●				0.7	0.6	-	0.8	1.0	1.0	1.4	4.0
105 A 074 ⁶⁾		2	Coax		●	PTFE	4	1.3	1.0	50	4.5	-	6.0	-	12.0
			1	●				1.3	1.1	-	1.6	-	2.0	-	12.0
105 A 089 ⁶⁾		5	Coax		●	PTFE	4	1.3	1.0	50	4.5	-	6.0	-	12.0
			4	●				0.9	0.75	-	1.5	2.0	2.3	2.8	7.0
105 A 095 ⁶⁾		10	Coax		●	PTFE	1	0.7	0.55	50	1.8	-	3.5	-	4.0
			9	●				0.9	0.75	-	1.4	1.5	2.2	2.5	6.0

¹⁾ See list of recommended cables on page B3-24.

²⁾ Test voltages between contact and body, as well as between contact and coaxial outer contact.

³⁾ Current per contact at 40°C temperature rise measured on the basic curve according to IEC 60512-5-2-5b. For the max. operating current a reduction factor must be used and limitations due to the size of the wires and the permissible upper temperature limit of the materials employed must be taken into account. See page A-12 for details.

⁴⁾ PEEK for main insulator and PTFE for Coax.

⁵⁾ Measured with S plug and D receptacle.

⁶⁾ DB body style not available.

B5-18 / B5-24

MIXED
HIGH VOLTAGE

PLUGS



CABLE MOUNTED

- Body styles (S; SV) B 5-19
- Technical dimensions B 5-20

RECEPTACLES



CABLE MOUNTED

- Body styles (D) B 5-21
- Technical dimensions B 5-22



FOR ALL MIXED HIGH VOLTAGE

- Electrical & contact configurations B 5-23
- Options B 3-26
- Insulating cable clamp sets B 2-59
- Accessories B 6-2
- Tooling B 6-19
- Technical information B 1-13
- Product specifications A-5

This catalog covers our standard connector solutions. For specific requests, including hybrid or custom connectors, please contact your local sales representative.

PLUGS

CABLE MOUNTED



Body style		S	SV	Links to detailed information
Protection	Unsealed (IP50)	●	●	Sealing categories, page A-6
	Sealed up to IP68			
Locking system	Friction			Locking systems, page A-5
	Push-pull	●	●	
	Quick-release			
	Lanyard			
	Tamperproof		●	
Contacts	Crimp			Electrical & contact configurations, page B 5-24
	Solder	●	●	
Housing color	Natural chrome	●	●	Options, page B3-26
	Black chrome	●		
Design	Shortened body			Body styles, page B 1-2
	Right-angle			
Cabling	Cable clamp sets	●	●	Insulating cable clamp sets, page B2-59 Cable assembly, page A-16
	Overmoldable			
	Heat shrinkable			
Accessories	Cable bend reliefs	●	●	Accessories, page B 6-2
	Protective sleeves	●		
	Sealing caps	●	●	
Size	102 Series			Technical dimensions, page B 5-20 For more information visit: www.fischerconnectors.com/technical
	103 Series			
	1031 Series			
	104 Series	●	●	
	105 Series	●	●	
	106 Series	●	●	
	107 Series			

MIXED
COAX & HIGH
VOLTAGE

PLUGS

CABLE MOUNTED

S

BODY STYLE

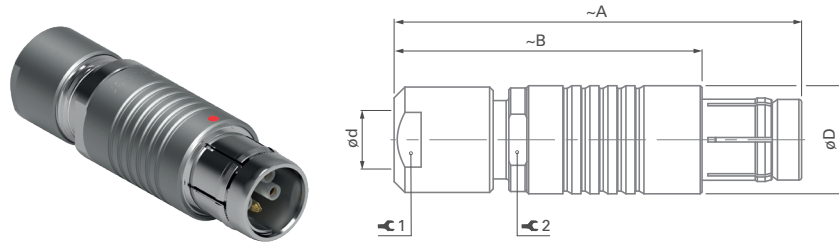

SV

BODY STYLE

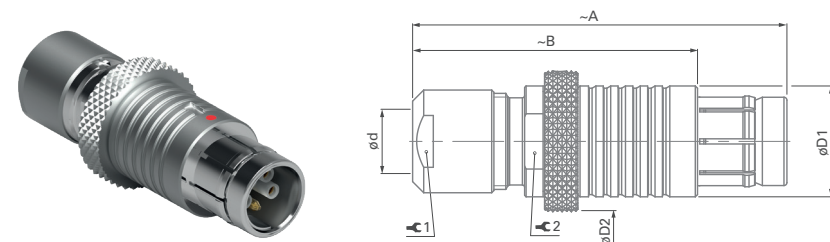

Series	A	B	D	d max		1	Torque 1 [Nm]	2
				Unsealed	Sealed			
104	50	38	15	8.7	8.7	12	2.0	13
105	62	47	18	10.7	10.7	15	3.5	16
106	80	55	28	19.2	19.2	22	8.0	-

Series	A	B	D1	D2	d max		1	Torque 1 [Nm]	2
					Unsealed	Sealed			
104	50	38	15	20	8.7	8.7	12	2.0	13
105	62	47	18	22	10.7	10.7	15	3.5	16
106	80	55	28	35	19.2	19.2	22	8.0	-

For insertion of female high voltage contacts which have to be assembled after wiring, we recommend tool TP00.000, shown on the Tooling section, page B 6-24.

These connectors are supplied with insulating cable clamps sets. The available inner diameters are listed on page B 2-59.

Some of these versions, however, can be delivered with special metal clamps, allowing the clamping of a cable screen. Please contact us for more information.

Torque [Nm] are recommended values that may be influenced by the characteristics of the cable jacket.

Tests must be conducted to evaluate the exact values. To secure the cable clamp nut, we recommend the use of thread locking adhesive.

RECEPTACLES

PANEL MOUNTED



Body style		D	Links to detailed information
Protection	Unsealed (IP50)	●	Sealing categories, page A-6
	Sealed up to IP68		
	Hermetic		
Contacts	Crimp		Electrical & contact configurations, page B5-24
	Solder	●	
	PCB		
Housing color	Natural chrome	●	Options, page B3-26
	Black chrome	●	
Design	Right-angle		Body styles, page B1-3
	Flush	●	
	Front-projecting		
	Bulkhead feedthrough		
Assembly	Front-mounting	●	
	Rear-mounting		
Accessories	Sealing caps	●	Accessories, page B6-2
	Spacers		
	Color-coded washers	●	
	Grounding washers	●	
	Locking washers	●	
Size	102 Series		Technical dimensions, page B5-22 For more information visit: www.fischerconnectors.com/technical
	103 Series		
	1031 Series		
	104 Series	●	
	105 Series	●	
	106 Series	●	
	107 Series		

All dimensions and images shown are in millimeters and are for reference only.

RECEPTACLES

PANEL MOUNTED

D

BODY STYLE

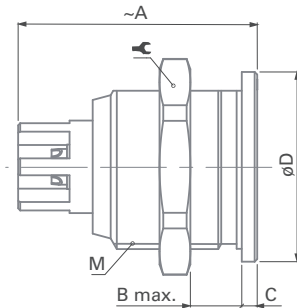

Types	A	B max.	C	D	M		Torque [Nm]
104 ^A / _Z 083	31	10.5	2.2	19	15x1	17	4.0
105 A 112	34	15.0	2.0	22	18x1	22	6.0

D

BODY STYLE

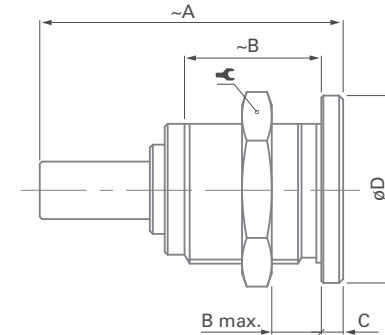

Types	A	B max.	C	D	M		Torque [Nm]
105 A 020 ¹⁾	54	15	2	22	18x1	22	6.0
105 A 036 ¹⁾	54	15	2	22	18x1	22	6.0
105 A 060 ¹⁾	58	15	2	22	18x1	22	6.0
106 A 014 ²⁾	49	18	3	37	32x1	TX00.106	15

¹⁾105 Series

The high voltage center contact is retained in a special insulator. To achieve proper high voltage performance, the window for soldering of the wire has to be covered by the supplied insulating tube, which must be placed over the cable before soldering.

²⁾ The D 106 A014 is supplied with a slotted nut.

The required hook spanner TX00.106 is shown on page B6-20.

For insertion of male high voltage contacts which have to be assembled after wiring, we recommend tool TP00.001, shown on page B6-24.

Torque [Nm] are recommended values that may be influenced by the quality of the panel surface. Tests must be conducted to evaluate the exact values.

A/Z POLARITY

For Mixed High Voltage connectors, it is essential to pay attention to the differences between type "A" and "Z".

Type "A" Standard Polarity

The contacts of the receptacle are recessed to reduce the possibility of electric shock in the unmated position.

This version should be used when the voltage is sourced from the receptacle.

Type "Z" Inverted Polarity

The contacts of the plug are recessed to reduce the possibility of electric shock in the unmated position.

This version should be used when the voltage is sourced from the plug.

Protected contacts are usually female contacts recessed in the insulator. For Mixed High Voltage connectors, however, it is safer to recess the male contacts.

In these cases, the plug type "A" is equipped with female contacts and the receptacle with protected male contacts.

This applies to all connectors on page B5-24 except 104 ^A 083 and 105 A 112.

EXAMPLE

receptacle
type "A"
D 105 A036

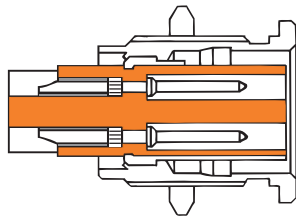

plug
type "A"
S 105 A036

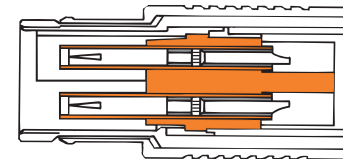

FOR 104, 105 & 106 SERIES

● = Standard ○ = Option

Reference	Pin layout	Number of contacts		Contact type		Insulating material	Contact \varnothing ²⁾ [mm]	Wire barrel \varnothing [mm]	Test voltage ⁶⁾ [kV] in mated position				Current ¹⁾ [A]
				Solder	Crimp				AC r.m.s		DC		
									Contact to body	Contact to contact	Contact to body	Contact to contact	
104 A Z 083 ⁵⁾		3	2 HT	●		PTFE	0.9	0.8	4.0	4.0	6.0	6.0	8.0
			1	●			1.6	1.8	2.2	4.5	3.5	6.5	18
105 A 020 ³⁾		3	1 HT	●		PTFE	2.0	2.0	6.0	6.0	14	14	20
			2	●			1.3	1.1	1.8	3.8	2.5	5.0	12
105 A 036 ³⁾		5	1 HT	●		PTFE	2.0	2.0	6.0	6.0	14	14	18
			4	●			1.3	1.1	1.8	2.0	2.5	3.0	12
105 A 060 ³⁾		8	1 HT	●		PTFE	2.0	2.0	6.0	6.0	14	14	16
			7	●			1.3	1.1	1.8	1.6	3.0	2.8	10
105 A 112 ⁴⁾		5	4 HT	●		PTFE	1.3	1.2	4.5	4.5	7.0	7.0	11
			1	●			2.0	2.0	2.0	4.5	3.0	7.0	11
106 A 014 ³⁾		8	2 HT	●		PTFE	2.0	2.4	7.0	15	14	23	16
			6	●			1.3	1.1	2.2	2.6	5.0	4.0	9.0

¹⁾ Current per contact at 40°C temperature rise measured on the basic curve according to IEC 60512-5-2-5b. For the max. operating current a reduction factor must be used and limitations due to the size of the wires and the permissible upper temperature limit of the materials employed must be taken into account. See page A-12 for details.

²⁾ Contact dia 2.0 is positioned to make contact first and break last.

³⁾ See Tooling section, page B6-23, for insertion tool of contact dia. 2.0.

⁴⁾ HT contacts are female and LV contact is male on plug.

⁵⁾ All contacts are male on plug with type A standard polarity.

⁶⁾ Measured with S plug and D receptacle.

B6

CHAPTER

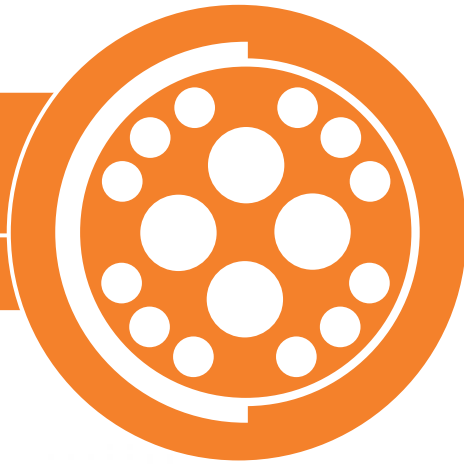

FISCHER CORE SERIES **BRASS** **ACCESSORIES & TOOLING**

- ACCESSORIES.....B6-2
- TOOLINGB6-19



CABLE MOUNTED PLUGS & RECEPTACLES

CABLE BEND RELIEFS

FOR INCREASED PROTECTION OF YOUR CONNECTIONS

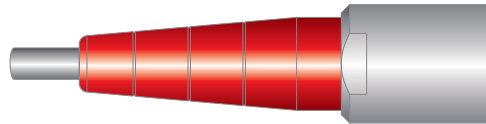

Suitable for :

- Cable mounted plugs (S/SC, SOV, SA, SV, WSO)
- Cable mounted receptacles (K/KE)
- Panel mounted cable receptacles (DKBE, DK, DKE)

Prevent cable torsion and increase protection of connection.

Color coding for easy identification when combined with color washer on a panel mounted connector.

KNURLED CLAMP NUTS

FOR RESISTANT HEAT SHRINKING

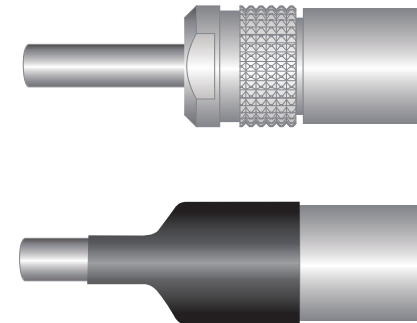

Suitable for :

- Cable mounted plugs (S/SC, SOV, SA, SV, WSO)
- Cable mounted receptacles (K/KE)
- Panel mounted cable receptacles (DKBE, DK, DKE)

Facilitates grip for a heat shrinkable tube acting as cable bend relief.

CABLE MOUNTED PLUGS & RECEPTACLES

PROTECTIVE SLEEVES

FOR IMPROVED PROTECTION

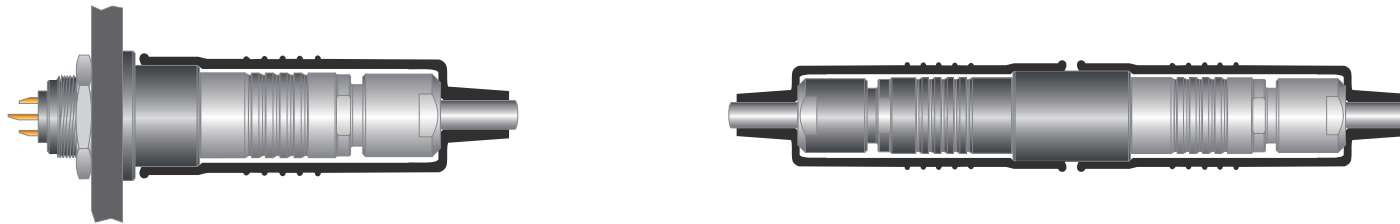

Suitable for :

- Cable mounted plugs (S/SC, SOV)
- Cable mounted receptacles (K/KE)

Protect against any foreign matter :

- Dust, dirt or mud
- Liquid splash

Minimize mechanical damage from impact on hard surfaces.

When mated, the front end of the protective sleeve encloses the projecting portion of the receptacle. When unmated, connectors can be protected with sealing caps.

PLUGS & RECEPTACLES

SEALING

CAPS

FOR PROTECTION OF UNMATED CONNECTORS IN THE FIELD

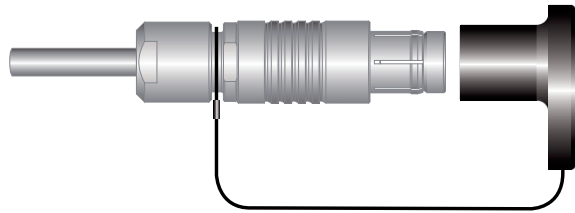

Suitable for:

- Cable mounted plugs (S/SC, SOV, SA, SV, SS/SSC, WSO)
- Cable mounted receptacles (K/KE, KS/KSE)

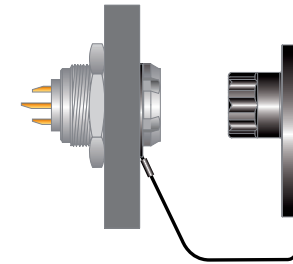

Suitable for:

- Panel mounted receptacles (D, DEU/E, DB, DBEU/E, DBP, DBPU/E, DBPLU/E, DG/DGP, DBPC, WDE)
- Panel mounted plugs (SF, SFU/E, SFPU/E)
- Panel mounted cable receptacles (DKBE, DK, DKE)

SOFT CAPS



- Lightweight
- Noiseless operation
- Operating temperature – 55°C to + 85°C
- IP68
- Easily installed
- Available in single-piece or lanyard model
- Intermateable to provide additional dust protection

METAL CAPS

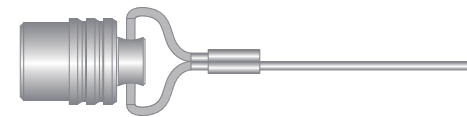

- Rugged
- Fitted with an o-ring seal
- Operating temperature – 30°C to + 200°C
- Protect & seal the mating face of the connector
- IP68
- State colors available

PANEL MOUNTED PLUGS & RECEPTACLES

SPACERS

TO ALLOW MOUNTING ON ALL PANELS

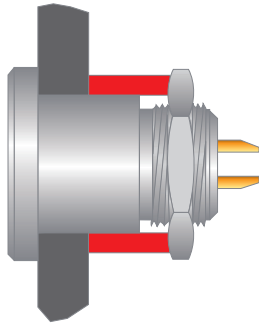

Suitable for :

- Feedthrough (WDE)
- Panel mounted receptacles (DEE, DEU, DKE)

Enables mounting on panels or bulkheads thinner than the unthreaded section.

COLOR CODING WASHERS

FOR EASY CONNECTOR IDENTIFICATION

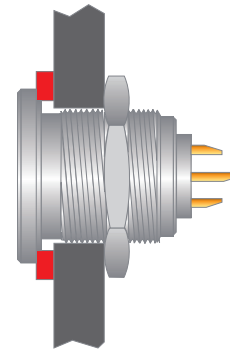

Suitable for :

- Panel mounted receptacles (D, DB, DBP, DBPC, DG, DGP, DK)
- Panel mounted plug (SF)

Can be mounted between the connector flange and the panel.

Color coding for easy identification when combined with colored cable bend relief for cable mounted connectors.

Not suitable for sealed version.

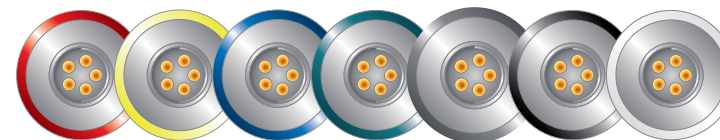

PANEL MOUNTED PLUGS & RECEPTACLES

INSULATING & COLOR WASHERS

FOR EASY CONNECTOR
IDENTIFICATION AND
EFFICIENT INSULATION

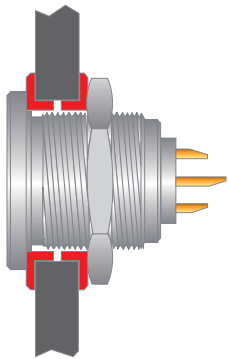

Suitable for panel mounted receptacle (D):

- Can be mounted on both sides of the panel cut-out
- Color coding for easy identification when combined with colored cable bend relief for cable mounted connectors.
- Isolate the connector body electrically from the panel
- Not suitable for sealed versions

GROUNDING WASHERS

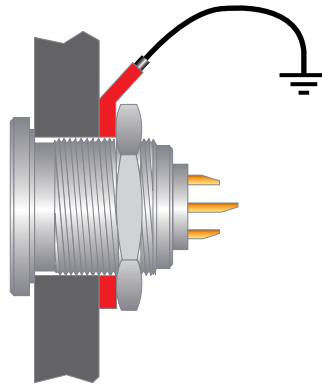

Suitable for panel mounted connectors

LOCKING WASHERS

TO ALLOW SECURE MOUNTING
ON ALL PANELS

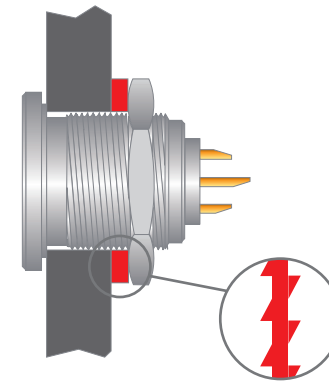

Suitable for panel mounted connectors

KNURLED CLAMP NUTS & CABLE BEND RELIEFS

KNURLED CLAMP NUTS

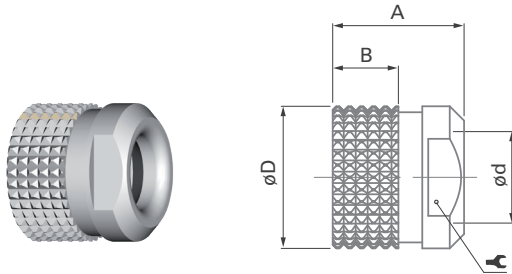

Series	A	B	D	d	⚙️	Part number
102	6	3.0	9	4.8	7	102.1869
103	11	5.5	12	6.5	10	103.2092
1031	12	5.5	13	7.2	12	1031.248
104	11	5.5	15	8.5	12	104.2103
105	14	7.5	18	11.0	15	105.2626

Material: nickel and chromium plated brass (ISO CuZn39Pb3)

CABLE BEND RELIEFS

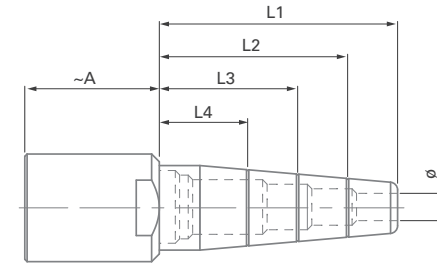
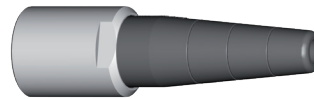

Series ¹⁾	Cable Ø range	Length	A
102	1.5 - 3.4	L1 = 21	10
	3.5 - 4.5	L1 = 21	
103	3.0 - 4.0	L1 = 26	17
	4.0 - 5.0	L2 = 21	
	5.0 - 6.2	L3 = 16	
1031	3.0 - 4.0	L1 = 26	18
	4.0 - 5.0	L2 = 21	
	5.0 - 6.5	L3 = 16	

Series ¹⁾	Cable Ø range	Length	A
104	4.0 - 5.0	L1 = 31	18
	5.0 - 6.5	L2 = 25	
	6.0 - 7.5	L3 = 18	
105	4.0 - 5.0	L1 = 37	21
	5.5 - 6.5	L2 = 31	
	7.0 - 8.5	L3 = 24	
	8.5 - 10.5	L4 = 18	

¹⁾ For the 102 Series, cable bend reliefs are designed specifically for a given cable Ø range.

For all other Series, cable bend reliefs have to be cut to length L1, L2, L3 or L4 to fit your cable Ø range.

Material:

Clamp nut: nickel and chromium plated brass (ISO CuZn39Pb3)

Bend relief: TPE (Thermoplastic elastomer)

These cable bend reliefs cannot be assembled with the clamp nuts supplied with the standard connectors.

Therefore, the cable bend reliefs are supplied as sub-assemblies.

CABLE BEND RELIEFS

NATURAL CHROME CONNECTORS

PART NUMBERS

Series ¹⁾	Cable ø range	Bend relief color						
		White	Black	Green	Blue	Yellow	Red	Grey
102	1.5 - 3.4	-	E4 102.190.2	E4 102.190.3	E4 102.190.4	E4 102.190.5	E4 102.190.6	E4 102.190.7
	3.5 - 4.5	-	E4 102.192.2	E4 102.192.3	E4 102.192.4	E4 102.192.5	E4 102.192.6	E4 102.192.7
103	3.0 - 6.2	E4 103.190.1	E4 103.190.2	E4 103.190.3	E4 103.190.4	E4 103.190.5	E4 103.190.6	E4 103.190.7
1031	3.0 - 6.5	E4 1031.190.1	E4 1031.190.2	E4 1031.190.3	E4 1031.190.4	E4 1031.190.5	E4 1031.190.6	E4 1031.190.7
104	4.0 - 7.5	E4 104.190.1	E4 104.190.2	E4 104.190.3	E4 104.190.4	E4 104.190.5	E4 104.190.6	E4 104.190.7
105	4.0 - 10.5	E4 105.190.1	E4 105.190.2	E4 105.190.3	E4 105.190.4	E4 105.190.5	E4 105.190.6	E4 105.190.7

BLACK CHROME CONNECTORS

PART NUMBERS

Series ¹⁾	Cable ø range	Bend relief color						
		White	Black	Green	Blue	Yellow	Red	Grey
102	1.5 - 3.4	-	E4 102.191.2	E4 102.191.3	E4 102.191.4	E4 102.191.5	E4 102.191.6	E4 102.191.7
	3.5 - 4.5	-	E4 102.193.2	E4 102.193.3	E4 102.193.4	E4 102.193.5	E4 102.193.6	E4 102.193.7
103	3.0 - 6.2	E4 103.191.1	E4 103.191.2	E4 103.191.3	E4 103.191.4	E4 103.191.5	E4 103.191.6	E4 103.191.7
1031	3.0 - 6.5	E4 1031.191.1	E4 1031.191.2	E4 1031.191.3	E4 1031.191.4	E4 1031.191.5	E4 1031.191.6	E4 1031.191.7
104	4.0 - 7.5	E4 104.191.1	E4 104.191.2	E4 104.191.3	E4 104.191.4	E4 104.191.5	E4 104.191.6	E4 104.191.7
105	4.0 - 10.5	E4 105.191.1	E4 105.191.2	E4 105.191.3	E4 105.191.4	E4 105.191.5	E4 105.191.6	E4 105.191.7

¹⁾ For the 102 Series, cable bend reliefs are designed specifically for a given cable ø range.
For other Series, cable bend reliefs have to be cut to length L1, L2, L3 or L4 to fit your cable ø range.

PROTECTIVE SLEEVES - 102 SERIES

S/SC & SOV

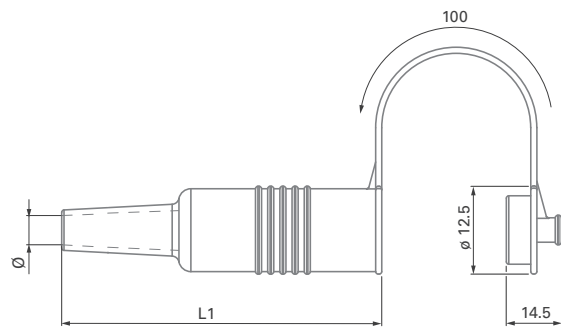
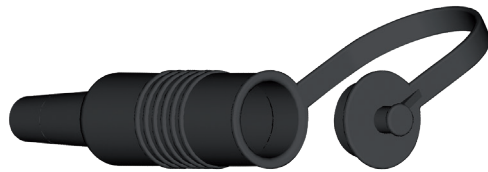

Series	Cable Ø Range	L1	Part number
102	1.8 - 4.5	56	102.785

Material: TPE (Thermoplastic elastomer).

K & KE

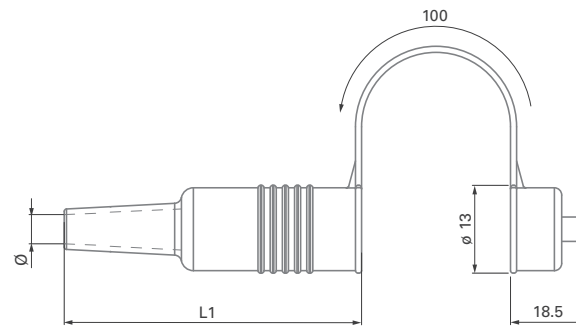
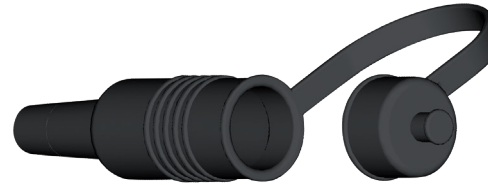

Series	Cable Ø Range	L1	Part Number
102	1.8 - 4.5	47	102.786

Material: TPE (Thermoplastic elastomer).

All dimensions and images shown are in millimeters and are for reference only.

PROTECTIVE SLEEVES - 103, 1031, 104, 105, 106 & 107 SERIES

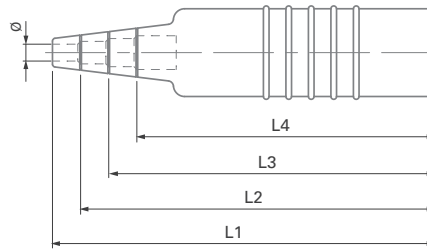

For S, SC and SOV

Series	Cable Ø range	Length	Part number
103	3.0 - 4.1	L1 = 68	103.861
	4.2 - 5.1	L2 = 63	
	5.2 - 6.1	L3 = 58	
	6.2 - 6.5	L4 = 53	
1031	3.0 - 4.1	L1 = 69	1031.855
	4.2 - 5.1	L2 = 64	
	5.2 - 6.1	L3 = 59	
	6.2 - 6.5	L4 = 54	

Series	Cable Ø range	Length	Part number
104	4.0 - 5.1	L1 = 83	104.861
	5.2 - 6.1	L2 = 76	
	6.2 - 7.1	L3 = 70	
	7.2 - 8.5	L4 = 63	
105	3.5 - 5.6	L1 = 104	105.1545
	5.7 - 7.6	L2 = 96	
	7.7 - 8.6	L3 = 88	
	8.7 - 10.5	L4 = 80	

Series	Cable Ø range	Length	Part number
106	6.0 - 10.4	L1 = 123	106.226
	10.5 - 13.4	L2 = 112	
	13.5 - 16.4	L3 = 102	
	16.5 - 19.0	L4 = 92	
107	7.0 - 10.4	L1 = 170	107.808
	10.5 - 13.4	L2 = 160	
	13.5 - 16.4	L3 = 150	
	16.5 - 19.4	L4 = 140	
	19.5 - 22.5	L4 = 130	

Material: TPE (Thermoplastic elastomer).

For K and KE

Series	Cable Ø range	Length	Part number
103	3.0 - 4.1	L1 = 60	103.886
	4.2 - 5.1	L2 = 55	
	5.2 - 6.1	L3 = 50	
	6.2 - 6.5	L4 = 45	
1031	3.0 - 4.1	L1 = 61	1031.860
	4.2 - 5.1	L2 = 56	
	5.2 - 6.1	L3 = 51	
	6.2 - 6.5	L4 = 46	

Series	Cable Ø range	Length	Part number
104	4.0 - 5.1	L1 = 68	104.862
	5.2 - 6.1	L2 = 61	
	6.2 - 7.1	L3 = 55	
	7.2 - 8.5	L4 = 48	
105	3.5 - 5.6	L1 = 88	105.1546
	5.7 - 7.6	L2 = 80	
	7.7 - 8.6	L3 = 72	
	8.7 - 10.5	L4 = 64	

Series	Cable Ø range	Length	Part number
106	6.0 - 10.4	L1 = 110	106.405
	10.5 - 13.4	L2 = 99	
	13.5 - 16.4	L3 = 89	
	16.5 - 19.0	L4 = 79	
107	7.0 - 10.4	L1 = 146	107.809
	10.5 - 13.4	L2 = 136	
	13.5 - 16.4	L3 = 126	
	16.5 - 19.4	L4 = 116	
	19.5 - 22.5	L5 = 106	



Material: TPE (Thermoplastic elastomer).

These protective sleeves for straight cable plugs and cable receptacles have grooved cable bend reliefs which can be shortened according to cable diameters. The lengths of the sleeves and the corresponding cable diameters are listed above.

LANYARD WITH THIN NYLON CORD

FOR PLUGS





Accessories	Description	Part number
	Crimp ferrule	300.637
	Crimp lug	300.299
	Heat shrink tube	300.930

Crimp ferrule, crimp lug and heat shrink tube have to be ordered separately.

FOR RECEPTACLES



Accessories	Description	Part number
	Crimp ferrule	300.637
	Crimp lug	300.299
	Heat shrink tube	300.930

Crimp ferrule, crimp lug and heat shrink tube have to be ordered separately.

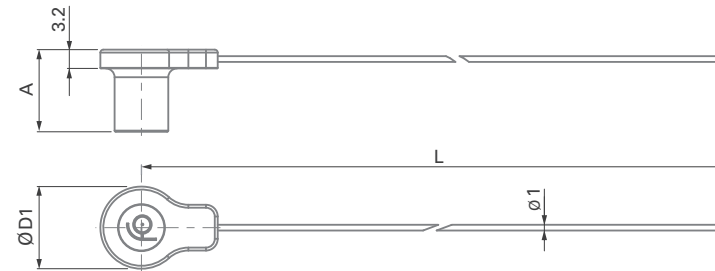

Series	A	D1	L	Part number
102	14.0	14	200	102.2180
103	14.7	17	200	103.2405
1031	14.0	18	200	1031.1432
104	16.0	20	200	104.2807
105	19.0	23	200	105.3264

Material: cap: Santoprene™ TPV 101-80 / Cord: Nylon.

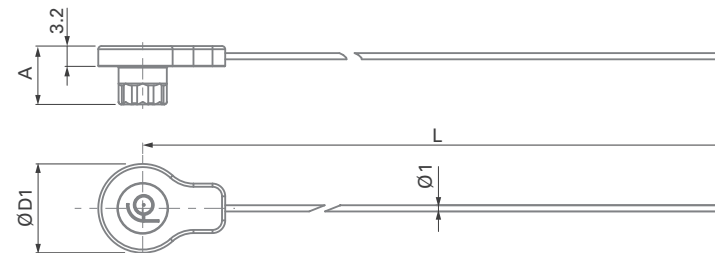

Series	A	D1	L	Part number
102	9.2	14	200	102.2181
103	9.7	17	200	103.2406
1031	9.5	18	200	1031.1433
104	10.0	20	200	104.2808
105	10.0	23	200	105.3265

All dimensions and images shown are in millimeters and are for reference only.

SOFT CAPS - ONE-PIECE

FOR PLUGS



Series	A	D1	L	Part number
102	14.0	14	122	102.2169
103	14.7	17	147	103.2399
1031	14.0	18	148	1031.1425
104	16.0	20	164	104.2766
105	19.0	23	186	105.3253

Material: cap: Santoprene™ TPV 101-80.

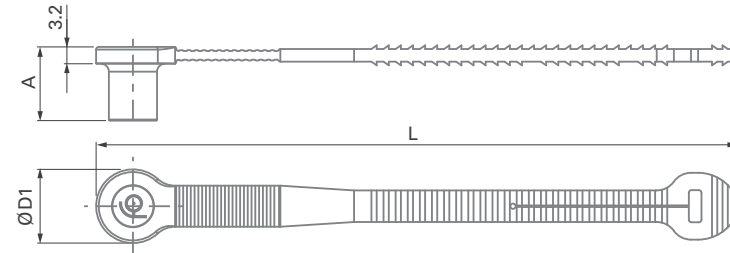

FOR RECEPTACLES



Series	A	D1	L	Part number
102	9.2	14	122	102.2166
103	9.7	17	147	103.2396
1031	9.5	18	148	1031.1422
104	10.0	20	164	104.2763
105	10.0	23	186	105.3250

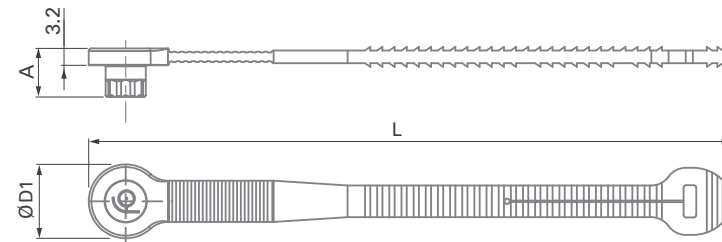

SOFT CAPS - LANYARD WITH STAINLESS STEEL CABLE

FOR PLUGS



Series	A	D1	L	Part number
102	14.0	14	200	102.2185
103	14.7	17	200	103.2404
1031	14.0	18	200	1031.1431
104	16.0	20	200	104.2806
105	19.0	23	200	105.3263

Crimp ferrule (300.922) and heat shrink tube (300.930) are included.
 Material: cap: Santoprene™ TPV 101-80 / Cable: Stainless steel with FEP-Teflon® covering.

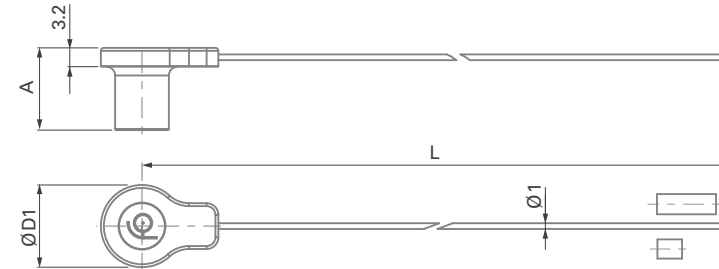

FOR RECEPTACLES



Series	A	D1	L	Part number
102	9.2	14	200	102.2167
103	9.7	17	200	103.2397
1031	9.5	18	200	1031.1423
104	10.0	20	200	104.2764
105	10.0	23	200	105.3251

Crimp ferrule (300.922), crimp lug (300.299) and heat shrink tube (300.930) are included.

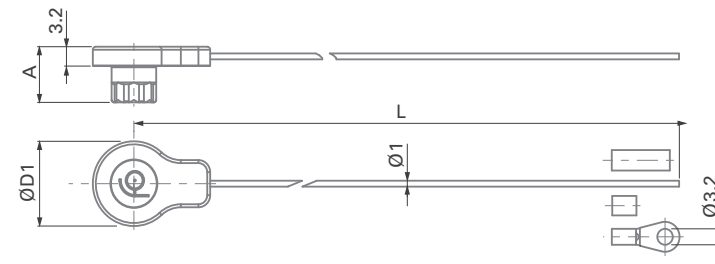

All dimensions and images shown are in millimeters and are for reference only.

SOFT CAPS - LANYARD WITH STAINLESS STEEL CABLE (PRE-ASSEMBLED)

FOR RECEPTACLES

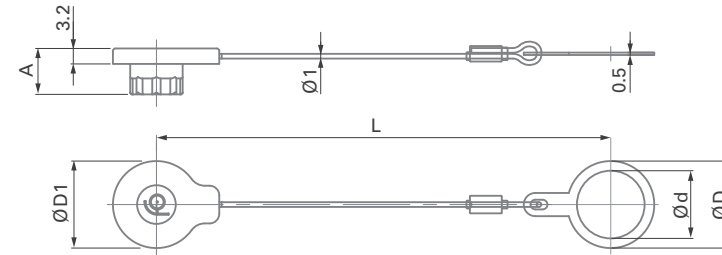

Series	A	D1	L	d	D	Part number
102	9.2	14	86	9	13	102.2182
	9.2	14	86	10	14	102.2165
103	9.7	17	93	14	18	103.2394
1031	9.5	18	94	14	18	1031.1434
	9.5	18	94	15	20	1031.1420
104	10.0	20	98	16	21	104.2761
105	10.0	23	100	20	25	105.3248

Crimp ferrule, heat shrink tube and fixing lug are included and mounted.

Material

Cap: Santoprene™ TPV 101-80
 Cable: Stainless steel with FEP-Teflon® covering
 Fixing lug: Black chrome plated brass (ISO CuZn37)



Caps are intermateable to provide additional dust protection.

METAL CAPS

FOR PLUGS ³⁾



Series	Part number		O-ring material	Caps		Stainless steel cable		Crimp ferrule
	Natural chrome ¹⁾	Black chrome ²⁾		A	D	Length	Covering material	Part number
102	102.1948	102.1952	FPM - Viton®	14.5	10	100	FEP - Teflon®	300.922
103	103.2274	103.2277		21.0	14	100		
1031	1031.825	1031.827		20.0	15	100		
104	104.715	104.717		21.0	15	150		
105	105.3002	105.3006		29.0	20	150		
106	106.813	106.815		37.0	33	250		
107	107.2312	107.2314		42.0	38	300		

Material: cap: natural or black chrome plated brass (ISO CuZn39Pb3) – Crimp ferrule: aluminium.

These metal caps are fitted with an O-ring seal. They protect and seal the mating face of the plugs and receptacles.

To attach the ferrule or the crimp lug to the stainless steel cable, use a crimp tool, a vice or a pair of pliers with parallel jaws. See page B6-21 for recommended crimping tool for ferrule.

¹⁾ Assembled with natural plastic covered stainless steel cable.

²⁾ Assembled with black plastic covered stainless steel cable.

³⁾ Not recommended for SFU; SFE; SFPE; SFPU. Use a soft cap instead.

FOR RECEPTACLES

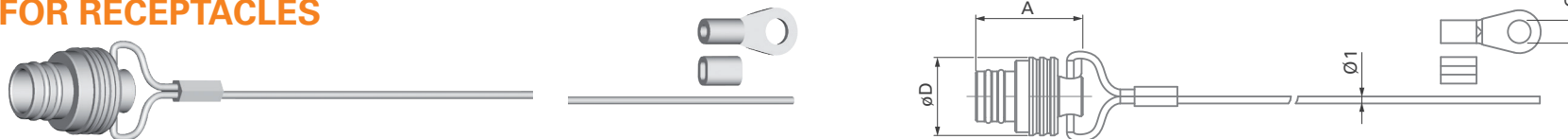

Series	Part number		O-ring material	Caps		Stainless steel cable		Crimp ferrule	Crimp lug
	Natural chrome ¹⁾	Black chrome ²⁾		A	D	Length	Covering material	Part number	Part number
102	102.1947	102.1951	NBR	15.0	11	100	FEP - Teflon®	300.922	300.299
103	103.2273	103.2276		15.0	13	100			
1031	1031.824	1031.826		17.0	15	100			
104	104.714	104.716		17.5	16	150			
105	105.3001	105.3005		21.0	19	150			
106	106.812	106.814		24.0	31	250			
107	107.2311	107.2313		26.0	36	300			

Material: cap: natural or black chrome plated brass (ISO CuZn39Pb3) – Crimp ferrule: aluminium – Crimp lug: tin plated copper.

All dimensions and images shown are in millimeters and are for reference only.

SPACERS

FOR WDE

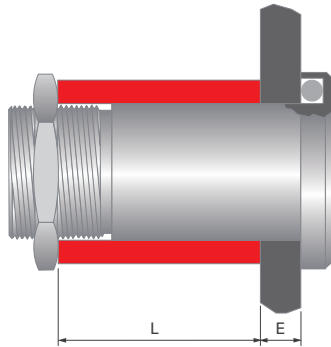

Series	E	L	Part number
106	0.5 - 8.5	30.0	106.560
	8.0 - 16.0	22.5	106.561
	15.5 - 23.5	15.0	106.562
	23.0 - 31.0	7.5	106.563
107	2.0 - 5.5	18.5	107.556
	5.0 - 8.5	15.5	107.557
	8.0 - 11.5	12.5	107.558
	11.0 - 14.5	9.5	107.559
	14.0 - 17.5	6.5	107.560
	17.0 - 20.5	3.5	107.561

Material: aluminium.

FOR DEE, DEU & DKE ¹⁾

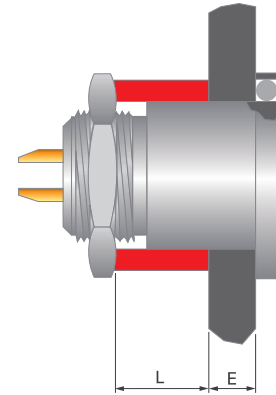

Series	E	L	Part number
102	0.5 - 3.0	8.5	102.550
	2.5 - 5.5	6.0	102.551
	5.0 - 8.0	3.5	102.552

Series	E	L	Part number
104	0.5 - 3.0	8.5	104.550
	2.5 - 5.5	6.0	104.551
	5.0 - 8.0	3.5	104.552

Series	E	L	Part number
106	0.5 - 5.5	19.0	106.550
	5.0 - 10.0	14.5	106.551
	9.5 - 14.5	10.0	106.552
	14.0 - 19.0	5.5	106.553

Material: aluminium.

Series	E	L	Part number
103 1031	0.5 - 3.0	8.5	103.550
	2.5 - 5.5	6.0	103.551
	5.0 - 8.0	3.5	103.552

Series	E	L	Part number
105	0.5 - 5.0	12.0	105.1121
	3.5 - 8.5	8.5	105.1122
	7.0 - 12.0	5.0	105.1123

Series	E	L	Part number
107	1.0 - 4.0	18.5	107.556
	4.0 - 7.0	15.5	107.557
	7.0 - 10.0	12.5	107.558
	10.0 - 13.0	9.5	107.559
	13.0 - 16.0	6.5	107.560
	16.0 - 19.0	3.5	107.561

¹⁾ Spacers are useful and available for DKE only in 102 and 103 Series.

WASHERS

COLOR CODING WASHERS

FOR D, DB, DBP, DBPC, DG, DGP, DK & SF

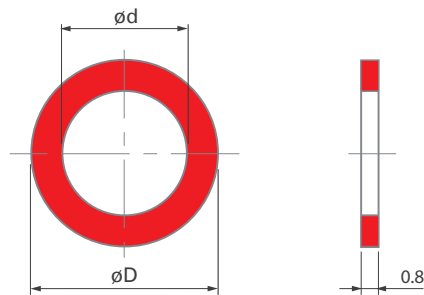

Series	D	d	Color						
			White	Black	Green	Blue	Yellow	Red	Grey
102	14.5	9	102.681	102.682	102.683	102.684	102.685	102.686	102.687
103	18.0	12	103.781	103.782	103.783	103.784	103.785	103.786	103.787
1031	20.0	14	1031.781	1031.782	1031.783	1031.784	1031.785	1031.786	1031.787
104 ¹⁾	23.0	15	104.981	104.982	104.983	104.984	104.985	104.986	104.987
105 ²⁾	26.0	18	105.2281	105.2282	105.2283	105.2284	105.2285	105.2286	105.2287

¹⁾ The connector style DB 104 requires an inner diameter d = 16 mm

Material: PP (Polypropylene).

²⁾ The connector style SF 105 requires an inner diameter d = 16 mm

INSULATING COLOR CODING WASHERS

FOR D RECEPTACLES

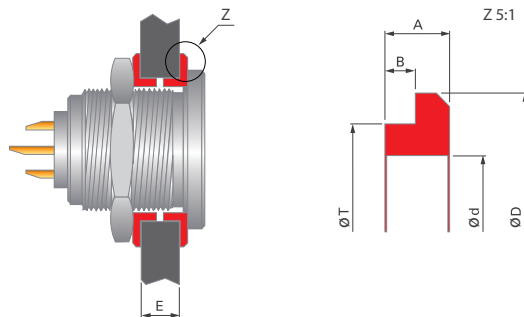

Series	D	d	T	A	B	E min/max	Color						
							White	Black	Green	Blue	Yellow	Red	Grey
102	12	9	10.6	1.5	0.6	1.3/6.5	102.791	102.792	102.793	102.794	102.795	102.796	102.797
103	15	12	13.9	2.0	1.0	2.1/5.0	103.382	103.383	-	-	-	-	-
104	19	15	17.0	2.0	1.0	2.1/8.5	-	104.377	-	-	-	-	-

Material:

102 Series: ABS (Acrylonitrile butadiene styrene).

103 and 104 Series: POM (Polyoxymethylene) Delrin®

WASHERS

GROUNDING WASHERS

FOR PANEL CONNECTORS

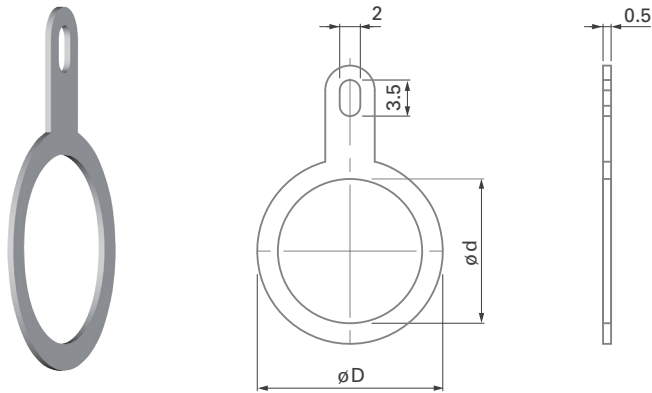

Series	D	d	Part number
102	13	9	102.680
	14	10	102.679
103	16	12	103.385
1031	18	14	1031.315
	20	15	104.680
104	21	16	104.679
105	23	18	105.680
	25	20	105.679

Material: copper and tin plated brass (ISO CuZn37).

LOCKING WASHERS

FOR PANEL CONNECTORS

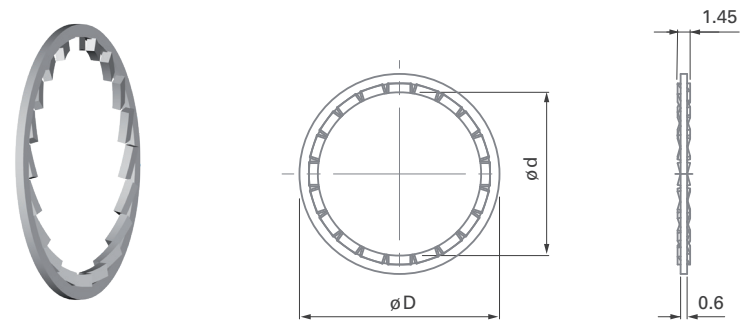

D	d	Part number
12.0	9	300.874
15.0	12	300.875
17.5	14	300.876
18.5	15	300.877

D	d	Part number
20	16	300.878
23	18	300.879
26	20	300.880
33	25	1052.338

Material: copper and tin plated brass (ISO CuZn37).

SPANNERS & NUT DRIVER

DOUBLE-END OPEN SPANNERS EXTRA THIN



Part number	Opening across flats	Length	Fork thickness
TX00.007	7	90	2.0
TX00.008	8	96	2.3
TX00.009	9	102	2.5
TX00.010	10	104	2.5
TX00.011	11	114	2.5
TX00.012	12	122	3.0
TX00.013	13	122	3.0
TX00.014	14	130	3.0

Material: chrome alloy steel, chrome plated, fork angles – 15° and 75°.

OPEN-END SPANNERS EXTRA THIN



Part number	Opening across flats	Length	Fork thickness
TX00.015	15	145	5.2
TX00.016	16	160	3.2
TX00.017	17	160	5.5
TX00.019	19	175	6.0
TX00.020	20	175	6.0
TX00.022	22	196	6.5
TX00.024	24	195	6.5
TX00.025	25	216	7.0
TX00.030	30	240	7.5
TX00.032	32	270	8.0

Material: chrome vanadium steel, chrome plated, fork angle – 15°.

All dimensions and images shown are in millimeters and are for reference only.

SPANNERS & NUT DRIVER

HOOK SPANNERS

FOR SIDE SLOTTED NUTS 



Part number	Thread size	Nut outer dia.
TX00.106	M30x1 / M32x1	34 – 38
TX00.107	M35x1 / M36x1	39 – 43

Material: hardened tool steel, gunmetal finish.

NUT DRIVER WITH T-HANDLE AND HEX DRIVE

FOR DECORATIVE SLOTTED NUTS 

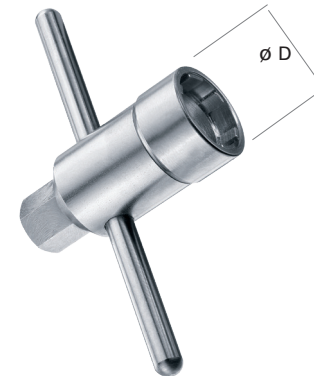

Part number	Thread size	Nut outer dia.	D	Hex drive
TC00.000	M9 x 0.5	12	15	7
TC00.007	M10 x 0.5	13	16	7
TF00.001	M12 x 1	15	18	10
TG00.001	M14 x 1	18	21	10
TK00.000	M15 x 1	19	22	12
TK00.002	M16 x 1	20	23	12
TP00.011	M18 x 1	23	26	12
TP00.005	M20 x 1	25	28	12

Material: hardened tool steel, nickel plated.

CRIMPING TOOLS

CRIMP TOOL ULTRA PRECISION

FOR CLOSED C CRIMP TERMINATION



Part number	Contact dia.	Crimp tool
TX00.240	0.5	BALMAR 18 - 000 or DANIELS MH - 800
	0.7	
	0.9	
	1.3	
TX00.242	1.6	ASTRO TOOL 615708

The best choice of precision crimp tools for highly reliable eight indenter crimping per US-MIL, IEC and DIN specifications.
Positioners have to be ordered according to contact.

Standards

IEC 60203 / DIN 41 611, Part 3 / MIL-C-22520, Class I, Type 1

FISCHER POSITIONER

SUITABLE FOR CRIMP TOOL TX00.240



SUITABLE FOR CRIMP TOOL TX00.242



For the choice of Fischer Connectors' positioner, please refer to page B2-26.

CRIMPING TOOLS

CRIMP TOOL

FOR COAXIAL CABLE



Part number	Description
TX00.241	The crimp tool for coaxial cable features a system of interchangeable dies (see below) that accommodate coaxial connectors and contacts used by Fischer Connectors.

CRIMPING DIES FOR PRECISION CRIMP TOOL

SUITABLE FOR CRIMP TOOL TX00.241

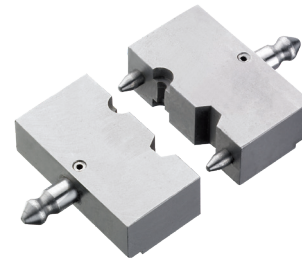

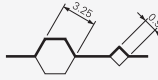
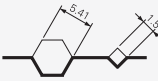
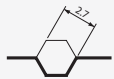
	Part number	Description
	TX00.250	Special crimping dies for coaxial cables of cable group 1 (RG-174 etc.). The hexagon corresponds to IEC 60803-B.
	TX00.251	Special crimping dies for coaxial cables of cable group 4 (RG-58 etc.). The hexagon corresponds to IEC 60803-D.
	TX00.265	Special crimping dies for crimp ferrule 300.922 of sealing caps

See page B3-23 for the table of cable designation.

FOR CRIMP AND HIGH VOLTAGE CONTACTS

CONTACT INSERTION TOOL



Part number	Contact dia.	Description
TX00.214	0.5	Tool for inserting male and female removable crimp contacts into the contact block. Especially recommended for small gauge and fragile wires.
TX00.210	0.7	
TX00.211	0.9	
TX00.273	1.3	

Material:
Handle: black POM (Delrin®).
Fork: tool steel, chrome plated.

CONTACT EXTRACTION TOOL



Part number	Contact dia.	Description
TX00.213	0.5	Tool for extracting male and female removable crimp contacts from the contact block.
TX00.200	0.7	
TX00.205	0.9	The sleeve of this tool is pushed over the contact, to release the contact retaining mechanism.
TX00.212	1.3	The tool plunger is then pushed to eject the contact.
TX00.201	1.6	

Material:
Housing and plunger: black POM (Delrin®).
Sleeve: stainless steel.
Slide: tool steel.

FOR CRIMP AND HIGH VOLTAGE CONTACTS

ASSEMBLY TOOL

FOR MALE CONTACTS WITH OUTSIDE THREAD



FOR FEMALE CONTACTS WITH INSIDE THREAD



Part number	Description
TP00.001	Tool for special contacts which are inserted only after termination to a wire ¹⁾ . To be used for : - Multipole HV Cable receptacle 107 A034 - Coax HV Plugs 105 A005 & 105 A108 - Mixed HV Cable receptacles 105 A020, 105 A036, 105 A060 Receptacles 106 A014

Material – Stainless steel: length 75 mm – Inside thread M3

¹⁾ Warning: these contacts are not removable after insertion into the contact block.

Part number	Description
TP00.000	Tool for special contacts which are inserted only after termination to a wire ¹⁾ . To be used for : - Multipole HV Plug 107 A034 - Coax HV Plugs 105 Z005 (right-angle only) & 105 Z049 Receptacles 105 A049, 105 A108 - Mixed HV Plugs 105 A020, 105 A036, 105 A060 & 106 A014

Material – Stainless steel: length 75 mm – Outside thread M1.7