

BROADCAST AND TELEVISION EQUIPMENT



Instructions

RADIO CORPORATION OF AMERICA, Industrial Electronic Products

Type BTF-10D 10KW

FM Broadcast Transmitter

EQUIPMENT LOST OR DAMAGED IN TRANSIT

When delivering the equipment to you, the truck driver or carrier's agent will present a receipt for your signature. Do not sign it until you have (a) inspected the containers for visible signs of damage and (b) counted the containers and compared with the amount shown on the shipping papers. If a shortage or if evidence of damage is noted, insist that notation to that effect be made on the shipping papers before you sign them.

Further, after receiving the equipment, unpack it and inspect thoroughly for concealed damage. If concealed damage is discovered, immediately notify the carrier, confirming the notification in writing, and secure an inspection report. This item should be unpacked and inspected for damage WITHIN 15 DAYS after receipt.

Report all shortages and damages to RCA, Broadcast and Television Department, Camden 2, N. J.

Radio Corporation of America will file all claims for loss and damage on this equipment so long as the inspection report is obtained. Disposition of the damaged item will be furnished by RCA.

REPLACEMENT PARTS AND ENGINEERING SERVICE

RCA field engineering service is available at current rates. Requests for field engineering service may be addressed to your RCA Broadcast Field Representative or the RCA Service Company, Inc., Broadcast Service Division, Camden, N. J. Telephone: WOODLAWN 3-8000.

When ordering replacement parts, please give symbol, description, and stock number of each item ordered.

The part which will be supplied against an order for a replacement item may not be an exact duplicate of the original part. However, it will be a satisfactory replacement differing only in minor mechanical or electrical characteristics. Such differences will in no way impair the operation of the equipment. Parts with no stock numbers are standard components. They are not stocked by RCA and should be obtained from your local electronic parts distributor.

The following tabulations list service parts and electron tube ordering instructions according to your geographical location.

SERVICE PARTS

LOCATION	ORDER SERVICE PARTS FROM:
Continental United States, including Alaska and Hawaii	RCA Electron Tube Division, Parts and Equipment, P.O. Box 654, Camden, New Jersey or through your nearest RCA Regional Office. Emergency orders may be telephoned, telegraphed, or teletyped to RCA Emergency Service, Bldg. 60, Camden, N. J. (Telephone: WO 3-8000).
Dominion of Canada	RCA Victor Company Limited, 1001 Lenoir Street, Montreal, Quebec or through your local Sales Representative or his office.
Outside of Continental United States, Alaska, Hawaii and the Dominion of Canada	RCA International Division, Clark, N. J., U.S.A. or through your local Sales Representative.

ELECTRON TUBES

LOCATION	ORDER ELECTRON TUBES FROM:
Continental United States, including Alaska and Hawaii	Local RCA Tube Distributor.
Dominion of Canada	RCA Victor Company Limited, 1001 Lenoir Street, Montreal, Quebec or through your local Sales Representative or his office.
Outside of Continental United States, Alaska, Hawaii and the Dominion of Canada	Local RCA Tube Distributor or from: Tube Department RCA International Division 30 Rockefeller Plaza New York 20, New York, U.S.A.

RETURN OF ELECTRON TUBES

If for any reason, it is desired to return tubes, please return them through your local RCA tube distributor, RCA Victor Co. Ltd., or RCA International Div., depending on your location.

PLEASE DO NOT RETURN TUBES DIRECTLY TO RCA WITHOUT AUTHORIZATION AND SHIPPING INSTRUCTIONS.

It is important that complete information regarding each tube (including type, serial number, hours of service and reason for its return) be given.

When tubes are returned, they should be shipped to the address specified on the Return Authorization form. A copy of the Return Authorization and also a Service Report for each tube should be packed with the tubes.

LIST OF RCA REGIONAL OFFICES

<p><i>Atlanta 3, Georgia</i> 1121 Rhodes-Haverty Bldg. 134 Peachtree St. N.W. JACKSON 4-7703</p>	<p><i>Boston 16, Mass.</i> Room 2301, John Hancock Bldg. 200 Berkley St. HUBBARD 2-1700</p>	<p><i>Chicago 54, Ill.</i> 1186 Merchandise Mart Plaza DElaware 7-0700</p>	<p><i>Cleveland 15, Ohio</i> 1600 Keith Bldg. CHerry 1-3450</p>
<p><i>Dallas 35, Texas</i> 7901 Empire Freeway FLEETWOOD 2-3911</p>	<p><i>Hollywood 28, Calif.</i> RCA Bldg., 1560 N. Vine St. HOLLYWOOD 9-2154</p>	<p><i>Kansas City 6, Missouri</i> 340 Home Savings Bldg. HARRISON 1-6480</p>	<p><i>New York 20, New York</i> 36 W. 49th St. JUDSON 6-3800</p>
<p><i>Branch—San Francisco 2, Calif.</i> 420 Taylor St. ORdway 3-8027</p>		<p><i>Seattle, Washington</i> 2250 First Ave., S. MAIn 2-8350</p>	

Memo for
your maintenance
file



TECHNICAL BULLETIN

MAINTENANCE AND MODIFICATION NOTES ON RCA BROADCAST EQUIPMENT

INDUSTRIAL ELECTRONIC PRODUCTS • BROADCAST AND TELEVISION EQUIPMENT DIVISION

- TB-72-9 BTF-5B FM Transmitter
- TB-84-5 BTF-5D FM Transmitter
- TB-82-7 BTF-10C/20C FM Transmitters
- TB-83-5 BTF-10D/20D FM Transmitters

October 10, 1962

Issued by W. D. Wenger/W. B. Fletcher

Page 1 of 2

Installation Information

Replacing 2CR1 and 2CR2 With Printed Circuit Rectifiers

Stock No. 222011

Improved printed circuit type rectifiers, RCA Stock No. 222011, are being shipped by Replacement Parts, superseding RCA Stock No. 217866. The new units must replace the old units in pairs. They may not be mixed.

The attached sketch gives detailed mounting and connection information. Care should be taken that the wire connecting the top of 2CR1 to the bottom of 2CR2 does not touch the rectifier or panel unless it is high voltage cable. (Spark plug h.v. ignition wire available at auto supply stores may be used.) An ohmmeter should be used to identify the four wires disconnected from the old rectifiers before reconnecting.

RADIO CORPORATION OF AMERICA • CAMDEN, NEW JERSEY

"The information contained in this bulletin is furnished as a free service to users of RCA equipment to aid in the maintenance, alignment or possible modification of such equipment. By furnishing this information, RCA assumes no obligation or responsibility to supply parts, to pay for the cost of modifications, to exchange existing equipment for new production models, or otherwise."

REPLACEMENT OF 2CR1-2CR2 IN BTF 5B, 5D, 10C, 10D, 20C and 20D WITH STOCK # 222011 RECTIFIERS

6-32 Bolt

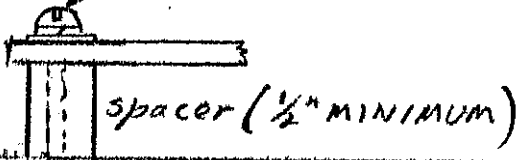

TAPPED SUGGESTED MOUNTING HOLE FOR REPLACEMENT RECTIFIERS

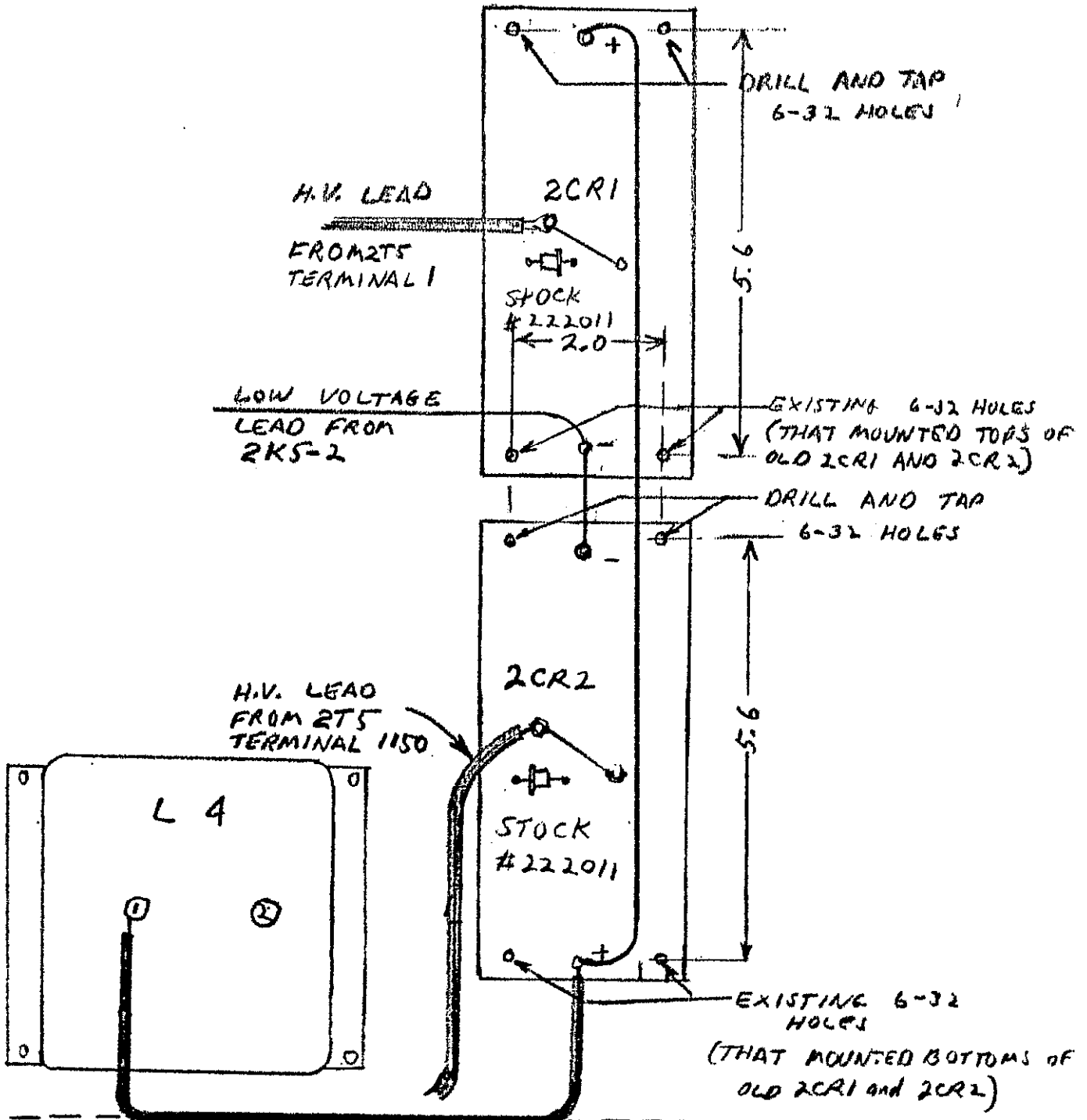

BROADCAST AND TELEVISION EQUIPMENT

INSTRUCTIONS

*RCA -- Camden N.J.
609-438-8000*

*PF694 Emergency Service
Department.*

Bill Reed.

Type BTF-10D 10KW

FM Broadcast Transmitter

ES-34225

BTE-10B "DIRECT FM" EXCITER

ES-27278

RADIO CORPORATION OF AMERICA
INDUSTRIAL ELECTRONIC PRODUCTS, CAMDEN, N. J.

FIRST AID

WARNING

OPERATION OF ELECTRONIC EQUIPMENT INVOLVES THE USE OF HIGH VOLTAGES WHICH ARE DANGEROUS TO LIFE. OPERATING PERSONNEL MUST AT ALL TIMES OBSERVE ALL SAFETY REGULATIONS. DO NOT CHANGE TUBES OR MAKE ADJUSTMENTS INSIDE THE EQUIPMENT WITH VOLTAGE SUPPLY ON. UNDER CERTAIN CONDITIONS DANGEROUS POTENTIALS MAY EXIST IN CIRCUITS WITH POWER CONTROLS IN THE OFF POSITION DUE TO CHARGES RETAINED BY CAPACITORS, ETC. TO AVOID CASUALTIES, ALWAYS DISCHARGE AND GROUND CIRCUITS PRIOR TO TOUCHING THEM.

Personnel engaged in the installation, operation and maintenance of this equipment or similar equipment are urged to become familiar with the following rules both in theory and in the practical application thereof. It is the duty of every radioman to be prepared to give adequate First Aid and thereby prevent avoidable loss of life.

ARTIFICIAL RESPIRATION

(Courtesy of the American Red Cross)

If victim is not breathing, begin some form of artificial respiration at once. Wipe out quickly any foreign matter visible in the mouth, using your fingers or a cloth wrapped around your fingers.

MOUTH-TO-MOUTH (MOUTH-TO-NOSE) METHOD



Fig. 1

Tilt victim's head back. (Fig. 1). Pull or push the jaw into a jutting-out position. (Fig. 2).



Fig. 2

If victim is a small child, place your mouth tightly over his mouth and nose and blow gently into his lungs about 20 times a minute. If victim is an adult (see Fig. 3), cover the mouth with your mouth, pinch his nostrils shut, and blow vigorously about 12 times a minute.



Fig. 3

If unable to get air into lungs of victim, and if head and jaw positions are correct, suspect foreign matter in throat. To remove it, place victim in position shown in Fig. 4, and slap sharply between shoulder blades.



Fig. 4

Rescuers who cannot, or will not, use mouth-to-mouth or mouth-to-nose technique should use a manual method.

THE BACK PRESSURE-ARM LIFT (HOLGER-NIELSEN) METHOD

Place victim face-down, bend his elbows and place his hands one upon the other, turn his head slightly to one side and extend it as far as possible, making sure that the chin is jutting out. Kneel at the head of the victim. Place your hands on the flat of the victim's back so that the palms lie just below an imaginary line running between the armpits (Fig. 5).



Fig. 5

Rock forward until the arms are approximately vertical and allow the weight of the upper part of your body to exert steady, even pressure downward upon the hands (Fig. 6).



Fig. 6

Immediately draw his arms upward and toward you, applying enough lift to feel resistance and tension at his shoulders (Fig. 7). Then lower the arms to the ground. Repeat this cycle about 12 times per minute, checking the mouth frequently for obstruction.



Fig. 7

If a second rescuer is available, have him hold the victim's head so that the jaw continues to jut out (Fig. 8). The helper should be alert to detect any stomach contents in the mouth and keep the mouth as clean as possible at all times.



Fig. 8

RELATED INFORMATION FOR BOTH METHODS

If vomiting occurs, quickly turn the victim on his side, wipe out his mouth, and then reposition him.

When a victim is revived, keep him as quiet as possible until he is breathing regularly. Keep him from becoming chilled and otherwise treat him for shock. Continue artificial respiration until

the victim begins to breathe for himself or a physician pronounces him dead or he appears to be dead beyond any doubt.

Because respiratory and other disturbances may develop as an aftermath, a doctor's care is necessary during the recovery period.

BURNS

FIRST DEGREE BURN

SKIN REDDENED. Temporary treatment—Apply baking soda or Unguentine.

SECOND DEGREE BURN

SKIN BLISTERED. Temporary treatment—Apply baking soda, wet compress, white petroleum jelly, foille jelly, olive oil, or tea.

THIRD DEGREE BURN

FLESH CHARRED. Temporary treatment—Apply baking soda, wet compress, white petroleum jelly, or foille spray. Treat for severe shock.

TABLE OF CONTENTS

	<i>Page</i>
BTF-10D 10KW FM TRANSMITTER SECTION	
LIST OF EQUIPMENT	T-5
RECOMMENDED SPARE PARTS	T-6
TECHNICAL SUMMARY	T-7
TUBE COMPLEMENT	T-7
DESCRIPTION	T-9
Construction	T-9
Circuits	T-9
BTE-10B Exciter	T-10
Intermediate Power Amplifier	T-10
Power Amplifier	T-10
Power Supplies and Control Circuits	T-12
INSTALLATION	T-13
Unpacking	T-13
Assembly	T-14
Harmonic Filter Installation	T-14
R-F Monitor Pickup Installation	T-14
Equipment Wiring	T-14
Transformer Primary Taps	T-15
Remote Control Connections	T-15
External Overload Connections	T-15
Preliminary Adjustments	T-15
Overload Relay Adjustment	T-16
Blower Adjustment	T-16
Control Circuit Check	T-16
Tube Installation	T-17
TUNING	T-17
Presetting of Controls	T-17
PA Neutralizing Adjustment	T-17
Exciter Warm-up	T-17
Amplifier Tuning	T-18
Typical Meter Readings	T-19
OPERATION	T-20
Overload Resetting	T-20
MAINTENANCE	T-20
Emergency Operation	T-20
Cleaning	T-21
Circuit Breakers and Relays	T-21
Tubes	T-21
Silicon Rectifiers	T-21
Recommended Maintenance Schedule	T-21
PARTS LIST	T-25
 BTE-10B FM MULTIPLEX EXCITER SECTION	
LIST OF EQUIPMENT	E-1
RECOMMENDED SPARE PARTS	E-1
TECHNICAL SUMMARY	E-3
TUBE COMPLEMENT	E-3
DESCRIPTION	E-4
Circuits	E-4
Automatic Frequency Control	E-6
Off-Frequency Detector	E-9
CRYSTAL FREQUENCIES	E-5

TABLE OF CONTENTS (Continued)

	<i>Page</i>
INSTALLATION	E-10
A-C Power Line Connections	E-10
Tune-Up Procedure	E-11
Oscilloscope Patterns	E-12
Off-Frequency Interlock Adjustment	E-13
OPERATION	E-13
Output Frequency Conversion	E-13
Main Carrier Deviation by Subcarrier	E-14
Subcarrier Modulation	E-15
Use of Control Tones	E-15
MAINTENANCE	E-15
Emergency Operation	E-15
Power Output Measurements	E-15
Tube Socket Voltages	E-16
Typical Meter Readings	E-16
Trouble Shooting Hints	E-17
PARTS LIST	E-25

LIST OF ILLUSTRATIONS

<i>Figure</i>	<i>Page</i>
BTF-10D 10KW FM TRANSMITTER SECTION	
1. RCA BTF-10D 10KW FM Transmitter	T-8
2. Block Diagram, BTF-10D FM Transmitter	T-11
3. Simplified Schematic Diagram, Intermediate Power Amplifier	T-11
4. Simplified Schematic Diagram, Power Amplifier	T-11
5. IPA Tuning Curve	T-22
6. PA Grid Tuning Curve (2I.8)	T-22
7. PA Plate Tuning and Plate Loading Curve	T-23
8. PA Screen Neutralizing Adjustment	T-23
9. PA Efficiency Curve	T-24
10. Screen Voltage vs. Power Output Curve	T-24
11. BTF-10D FM Transmitter, Front View, Doors Closed	T-30
12. BTF-10D FM Transmitter, Front View, Doors Open	T-31
13. BTF-10D Transmitter, Rear View, Door and Panels Removed	T-32
14. BTF-10D Power Amplifier Cubicle, Rear View	T-33
15. BTF-10D 250-Watt IPA, Front Panel Removed	T-34
16. BTF-10D Power Amplifier, Open Door View	T-34
17. BTF-10D Power Amplifier, Door Open, Panel Removed	T-35
18. PA Tube Socket, Top View	T-36
19. PA Tube Socket, Bottom View	T-36
20. Harmonic Filter, Technical Summary	T-37
21. Harmonic Filter, Schematic Diagram	T-37
22. Interconnection Diagram, BTF-10D (364539)	T-39
23. Cable Assembly and Connections (8616018)	T-41
24. Cabinet Installation Diagram (8616031)	T-43
25. Installation/Wiring Diagram (8616072)	T-45
26. Installation/Wiring, Plate Transformer (8729601)	T-47
27. Overall Schematic Diagram BTF-10D (8312960)	T-49
BTE-10B FM MULTIPLEX EXCITER SECTION	
1. BTE-10B FM Multiplex Exciter	E-2
2. Block Diagram, BTE-10B FM Exciter	E-6

LIST OF ILLUSTRATIONS (Continued)

<i>Figure</i>		<i>Page</i>
3.	Simplified Schematic, BTE-10B Phase Detector	E-7
4.	Phase Detector Signal Voltages	E-8
5.	Phase Detector Output Waveforms	E-9
6.	Simplified Schematic, Off-Frequency Detector	E-10
7.	BTE-10B Oscilloscope Patterns	E-12
8.	Schematic, 18 db Attenuator	E-13
9.	Chart, Deviation of Carrier Frequency by the Sub-carrier	E-14
10.	Connections for Measuring Power Output	E-15
11.	BTE-10B FM Exciter, Front View	E-20
12.	BTE-10B FM Exciter, Rear View	E-21
13.	BTE-10B FM Exciter, Rear View	E-22
14.	BTE-10B FM Exciter, Rear View	E-23
15.	Views of PA and Oscilloscope Subassemblies	E-24
16.	Overall Schematic Diagram, BTE-10B FM Exciter (364351)	E-31
17.	Interconnection Diagram, BTE-10B/BTX-1A (364539)	E-33

LIST OF EQUIPMENT

BTF-10D, 10 KW, FM TRANSMITTER (ES-34223)			
	<i>Quantity</i>		<i>Reference</i>
	1	BTE-10 B, FM Exciter Unit	MI-34501
	1	Crystal Unit	MI-34509
	1	Set of Operating Tubes	MI-34510
	1	250-Watt Driver	MI-34502-A
	1	10 KW Amplifier	MI-34554
	1	Plate Transformer	MI-34555
	1	Blower	MI-34556
	1	Installation Material Kit	MI-34553
	1	Side Panel (End Shield)	MI-34531-2
	1	Finish Touch-up Kit	MI-27660
	1	Tool Kit	MI-27088
	1	Set of Operating Tubes (4CX5000A, 7034)	MI-34704, MI-34511
	1	Harmonic Filter	MI-27967-1 or 2
	1	Doors (color as specified)	MI-27645-D-* or E-*
	1	Nameplate	MI-28180-1
	1	1 7/8" to 3/8" Adapter	MI-19112-7
	2	Couplings	MI-19112-8
	2	Instruction Books, BTF-10D	IB-30280
INSTALLATION MATERIAL KIT (MI-34553)			
<i>Item</i>	<i>Quantity</i>	<i>Description</i>	<i>Reference</i>
1	1	Logotype (FM Broadcast)	8708450-1
2	1	Logotype (Type BTF-10D)	8700106-11
3	1	RCA Monogram	8430354-1
4	12	Retainer (Spares Included)	990502-108
5	4	Clamp, Hose	8824489-8
6	1	Screen	8907769-13
7	1	Duct Assembly	8723450-502
8	4	Clamp	8917199-8
9	1	Boot	8820789-4
10	6	Plate	8973856-1
11	2	Crank Assembly	8918002-501
12	2	Arm Assembly	887449-501
13	1	Directional Coupler, 2Z1	8434079-3
14	1	Monitor Assembly	8442950-503
15	1	Elbow, Miter	8829487-3
16	1	Escutcheon	8314777-2
17	1	Trim Strip	8448474-501
18	1	Plug Button	8872221-105

LIST OF EQUIPMENT. (Continued)

INSTALLATION MATERIAL KIT (MI-34553) (Continued)			
<i>Item</i>	<i>Quantity</i>	<i>Description</i>	<i>Reference</i>
19	1	Capacitor, 2C21	990194-51
20	6	Rectifier Assembly, 2CR12 thru 2CR17	8720774-502
21	1	Reactor, 2L3	900431-4
22	1	Suitable Container Containing Hardware (Spares Included):	
23	1	Wire, #6 AWG, 150', 600 V, Grey	2010702-838
24	1	Wire, #14, AWG, 200', 15,000 V, Black	883852-1
25	1	Strap, Copper, 25, 1.5 In. Wide	8812985-6
26	1	Suitable Container Containing (Spacer Included):	
		(A) 10 Terminal	818337-2
		(B) 8 Terminal	8898696-54
27	1	Cable Harness:	
		(A)	8616018-502
		(B)	757412-507
28	1	Cable Assembly	8460367-501
29	1	Cable Assembly	8460367-503
30	1	Instruction Book BTF-10D Transmitter	IB-30280

RECOMMENDED SPARE PARTS

10 KW AMPLIFIER (DRIVER AND POWER AMPLIFIER)				
<i>Description</i>	<i>Symbol</i>	<i>Quantity</i>	<i>Stock No.</i>	
Capacitor, Var. 4.5-102 μf	1C1, 1C13, 2C3	1	217634	
Capacitor, ceramic, 25 μf	1C2	1	215859	
Capacitor, feed thru, 470 μf	1C3, 1C5, 1C7, 1C11, 1C15-1C18	1	217636	
Capacitor, silver mica	1C6, 1C8, 1C10	2	95707	
Screw, lead, teflon	part of 1L1 and 1L2	1	219131	
Belt, drive	part of blower, 2B1	1	221587	
Capacitor, ceramic, 1000 μf	1C14, 2C4, 2C15, 2C28-2C30, 2C32, 2C33	1	211186	
Capacitor, ceramic, 50 μf	2C10, 2C25	1	217653	
Capacitor, feed thru, 1000 μf	2C5, 2C11	1	211140	
Mica	part of 2C12	1	217645	
Rectifier circuit	2CR7	1	220285	
Bulb		5	16154	
Resistor, wire wound, 4 ohm	2R16	1	217615	
Contact Assembly	part of 2L8	1	217650	
Contact Assembly	part of 2L6 and 2L7	2	217649	
Filter	air filter	1	95160	

TECHNICAL SUMMARY

(Refer to the Exciter Section of this book for exciter technical data.)

Electrical Characteristics	
Type of Emission	F3 and F9
Frequency Range	88 to 108 mc
Power Output	1 to 10 KW
Output Impedance (1 $\frac{1}{8}$ " O.D. Line)	51.5 ohms
Frequency Deviation 100% Modulation	± 75 KC
Modulation Capability	± 100 KC Min.
Carrier Frequency Stability	± 1000 cycles Max.
Audio Input Impedance	600/150 ohms
Audio Input Level ¹ (100% Mod.)	+10 ± 2 dbm
Audio Frequency Response ² (30-15,000 cycles)	± 1 db Max.
Harmonic Distortion ³ (30-15,000 cycles)	0.5% or less
FM Noise Level (referred to 100% FM Mod.)	-65 db Max.
AM Noise Level (referred to 100% AM Mod.)	-50 db Max.
Subcarrier Input Level (30% modulation)	5 v Max. ⁴
Subcarrier Input Impedance	10,000 ohms
Subcarrier Center Frequency Range	30-67 KC/s ⁷
Main-to-Sub-channel Crosstalk	-55 db ⁵
Sub-to-Main-channel Crosstalk	-65 db ⁶
Power Line Requirements	240/208 v., 50/60 cps., 3 phase
Slow Voltage Variation	$\pm 5\%$
Power Consumption	20,000 watts (approx.)
Power Factor	90%
Crystal Heaters	117 v., 50/60 cps., single phase, 28 watts
Environmental Specifications	
Altitude	7500 ft. Max.
Ambient Temperature Range	0-45°C
Heat Dissipation	34,000 BTU/hr. (approx.)
Mechanical Specifications	
<i>Dimensions and Weights</i> (Dimensions are for uncrated units and do not include door handles and controls.)	
	<i>Weights</i>
	<i>Height</i> <i>Width</i> <i>Depth</i> <i>Packed</i> <i>Unpacked</i>
Exciter and IPA Cabinet (less doors)	84" 25" 20 $\frac{1}{16}$ " 380 lbs. 270 lbs.
PA Cabinet (less doors)	84" 34 $\frac{1}{2}$ " 32" 1094 lbs. 855 lbs.
Doors and Miscellaneous Items 225 lbs. 180 lbs.
Blower 118 lbs. 100 lbs.
Power Transformer	36" 27 $\frac{1}{2}$ " 19 $\frac{1}{4}$ " 655 lbs. 615 lbs.
Overall	84" 59 $\frac{1}{2}$ " 32" 2472 lbs. 2020 lbs.

¹ Level measured at input (J101), using 400 cps tone.

² Audio frequency response referred to 75 μ s pre-emphasis curve.

³ Distortion includes all harmonics up to 30 KC/s and is measured following a standard 75 μ s de-emphasis network.

⁴ Subcarrier modulation percentage can be brought to 50% if required. (Refer to the Exciter Section of this book.)

⁵ Reference shall be ± 7.5 KC deviation of the sub-carrier by a 400 cps tone.

⁶ Main channel modulated 70% by 50-15000 cps tones. Sub-channel modulated 100% (± 7.5 KC) by 30-6000 cps tones. Sub-carrier modulated 30% on main carrier.

⁷ The subcarrier modulator will accept any frequency from 0 to 100 KC.

TUBE COMPLEMENT

250-Watt Driver and 10 KW Power Amplifier. (Refer to the Exciter Section for the Exciter tube complement.)

Symbol	Type	Function
1V1	7034*	250-Watt RF Driver
2V1	4CX5000A	10 KW Power Amplifier

* The Type 7034 tube is not bilaterally interchangeable with the Type 4X150A tube. However, a Type 7203 or Type 4CX250B may be used if the Type 7034 is not available.



Figure T-1. RCA BTF-10D 10KW FM Transmitter

DESCRIPTION

The RCA Type BTF-10D FM Transmitter (Figure 1) is designed for high fidelity FM broadcasting on any frequency between 88 and 108 megacycles, with a power output of 10,000 watts.

The transmitter employs the new BTE-10B FM Exciter. This exciter incorporates a subcarrier modulator and can be used with the BTX-1A Subcarrier Generator to provide for various applications of FM multiplex such as background music and, if it becomes authorized, stereophonic sound broadcasting. Incorporating simplified circuitry and improved mechanical layout, the BTF-10D is a compact, high-power transmitter designed to provide long trouble-free service with maximum operational ease and efficiency.

Air-cooled tubes are employed in all stages of the transmitter which consist of the FM exciter unit, 250-watt driver and 10 kw power amplifier. The exciter utilizes miniature tubes and incorporates a subcarrier modulator stage for the multiplexing of one or more FM channels on one r-f carrier. The BTX-1A Subcarrier Generator is available as an accessory for this type service.

The BTF-10D is conservatively designed for unattended operation. Functions such as starting and stopping of the transmitter, resetting overload relays, metering of all power amplifier circuits and monitoring power output can be performed at a remote location as well as at the transmitter by the addition of available remote control accessories.

Construction

The transmitter is housed in two steel cabinets which are bolted together at installation. One cabinet contains the exciter, r-f driver and the subcarrier generator (if used), the other cabinet contains the power amplifier, blower, power supplies and control circuits. The plate transformer is housed in its own external enclosure.

Circuitry and mechanical layout of the transmitter are arranged to permit maximum accessibility. Vertical chassis type construction is employed, with surface mounting of components and wiring for easy and speedy tracing of circuits during servicing. Doors and removable panels provide access to all components of the transmitter. Meters and indicator lights are grouped with tuning and switching controls at convenient height on the front of the transmitter. An additional cabinet (ES-34211-A) which matches the appearance of the 250-watt driver cabinet may be added to the left side of the transmitter to house accessory units for frequency and modulation monitoring, multiplexing, and remote control.

Safety of operating personnel has been given special consideration in the design of the transmitter. All access doors to compartments containing high voltages are equipped with automatic interlock switches. When these doors are opened all rectifiers are immediately de-energized. In addition, each compartment containing high voltage is equipped with a mechanically operated grounding bar which is automatically released when the door is opened, or panels are removed.

Forced air cooling for the intermediate amplifier and power amplifier tubes is provided by a blower (2B1) located in the bottom of the left hand cubicle. Air is fed through a canvas boot into the bottom of the power amplifier compartment. Air for the 7034 IPA tube is fed by a 2 inch hose from the power amplifier compartment (through the wall of the cabinet) to the bottom of the IPA chassis. Air interlock switches in both stages remove plate and screen voltages if the air supply is interrupted.

Circuits

A block diagram of the BTF-10D transmitter is shown in Figure 2. High gain tetrodes are employed in the IPA and PA stages following the exciter which has a rated power output of ten watts. The IPA utilizes a 7034 tetrode delivering approximately 250 watts of r-f power. The final power amplifier employs a type 4CX5000A tetrode which supplies up to 10 kw of cw power to the 1 $\frac{5}{8}$ inch antenna feed line. Both tubes operate in grounded cathode circuits. A variable output screen supply, common to the IPA and PA stages provides a means for obtaining any desired output power from one to ten kilowatts.

Frequency modulation is accomplished in the BTE-10B FM exciter by a "direct modulation" process requiring less components and fewer tubes and tube types. This process, which eliminates numerous multipliers and converter stages (resulting in low noise and minimum distortion), utilizes push-pull reactance tubes connected across the frequency determining circuit of the master oscillator. The center frequency of this oscillator is precisely maintained by a temperature controlled reference crystal in the exciter.

All power supplies employ semi-conductor rectifiers. The high voltage supply furnishes 6300 volts to the final stage and 2000 volts to the plate of the IPA. Another power supply furnishes screen voltages for these stages. The exciter unit as well as the accessory subcarrier generator are equipped with built-in power supplies.

Control circuits provide a 45-second starting sequence which prevents the application of plate voltage until the blower is in operation, tube filaments have reached operating temperature and the exciter has become stabilized. These circuits also provide overload protection and off-frequency shutdown. The overload circuit automatically returns the transmitter to the air on the first two overloads after a clearing time of two seconds. If the overload persists for the third time, manual resetting is required. Overload relays are located in the high voltage and screen supplies and in the cathode circuits of the IPA and power amplifier. Terminal board connections are available for transmitter remote control and metering functions. Only two fuses are used in the transmitter. These are installed in the crystal heater circuits on the exciter chassis.

BTE-10B FM Exciter

The BTE-10B Exciter provides a frequency modulated r-f output of ten watts at the specified carrier frequency. The exciter incorporates a subcarrier modulator stage which can be fed from the RCA Type BTX-1A Subcarrier Generator to provide for multiplexing one or two subcarriers on the main FM channel. For detailed information on the exciter unit, refer to the BTE-10B Exciter Section of this book.

Intermediate Power Amplifier

The intermediate power amplifier, which employs a 7034 tetrode, is a panel and chassis type unit and is mounted vertically in the right-hand cabinet of the transmitter, above the exciter. All controls are located on the front panel and consist of two crank-handle operated adjustments labeled INPUT TUNING (1L1) and OUTPUT TUNING (1L2), and two screwdriver-adjusted capacitors labeled INPUT LOADING (1C1) and OUTPUT LOADING (1C13). These adjustments are accessible when the front door of the cabinet is open.

Output from the exciter is fed to the grid circuit of the IPA through a 50-ohm coaxial cable from an r-f output jack (1P1) located on the rear of the chassis. Forced air, conveyed from the blower by a two-inch diameter hose, enters the bottom of the chassis and is expelled through louvres in the rear plate. A-C and D-C connections to the unit are made to a terminal strip on the rear of the chassis.

Circuits of the intermediate power amplifier are shown in the simplified schematic diagram of Figure 3. The input and output tuning circuits are conventional "pi" networks utilizing the input and output capacitance of the tube. The tuning slugs in inductances 1L1 and 1L2 move longitudinally by threaded

teflon driving lead screws which are mechanically linked to the crank handle adjustments on the front panel. These slugs are brass with a silver plating. Their operation differs from that of the usual tuning slug in that the effective inductance of the coil is decreased as the slug is moved toward the coil center. No neutralization is required in this stage. Bias for the tube is obtained from grid and cathode resistances.

Power Amplifier

The power amplifier is located in a compartment in the lefthand cubicle of the transmitter with the power supplies, blower and control circuits. This stage utilizes a Type 4CX5000A forced-air cooled tetrode which provides a power output of 10 kw to the 51.5-ohm transmission line.

All controls for tuning and loading of the amplifier are located at convenient height on the lefthand vertical front panel of the transmitter. These consist of the GRID LOADING control (2C3), GRID TUNING (2L8), PLATE TUNING (2L6), and PLATE LOADING (2L7). R-F power from the 250-watt driver is fed through a 50-ohm cable to a coaxial jack (2J1) in the bottom of the PA compartment. R-F output is coupled to a 51.5-ohm transmission line which enters the top of the compartment.

Power amplifier circuits are shown schematically in Figure 4. The input circuit is a modified pi network in that the input capacity of the tube is shunted by an inductive line (2L8) which reduces the effective input capacity of the stage. Inductance (2L10), which is varied by means of a capacitor (2C3) in parallel with the coil, also provides the means for adjustment of input loading. The output circuit of this stage is also a pi network with the tube capacity shunted by the variable inductance 2L6. Loading and tuning are accomplished by variation of the two inductive line components 2L6 and 2L7. Mechanical simplicity was obtained in this circuit by inverting the pi network, thus placing one end of the inductance at ground potential as shown. This eliminates the mechanical and electrical problems of insulating the variable component from ground. It is necessary that the output line parallel the inductance to bring it to ground potential. This is achieved by the extension of the output line down one side of the inductive line. Neutralization of the power amplifier is accomplished by adjusting the spacing of neutralizing slides located at the base of the tube.

In addition to grid leak bias, a separate bias supply is incorporated in the power amplifier. This bias supply consists of a silicon bridge rectifier assembly (2CR7) and a choke input filter circuit which supplies 40 to 50 ma. to bias the grid of the PA tube.

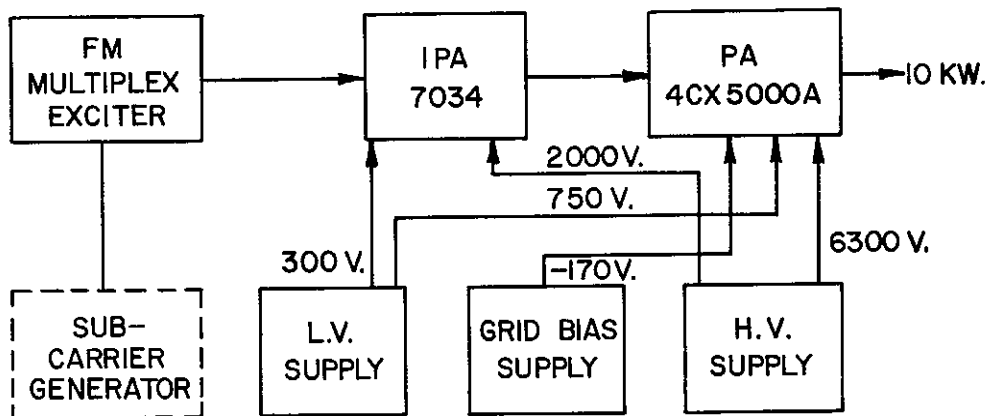

Figure T-2. Block Diagram, BTF-10D FM Transmitter

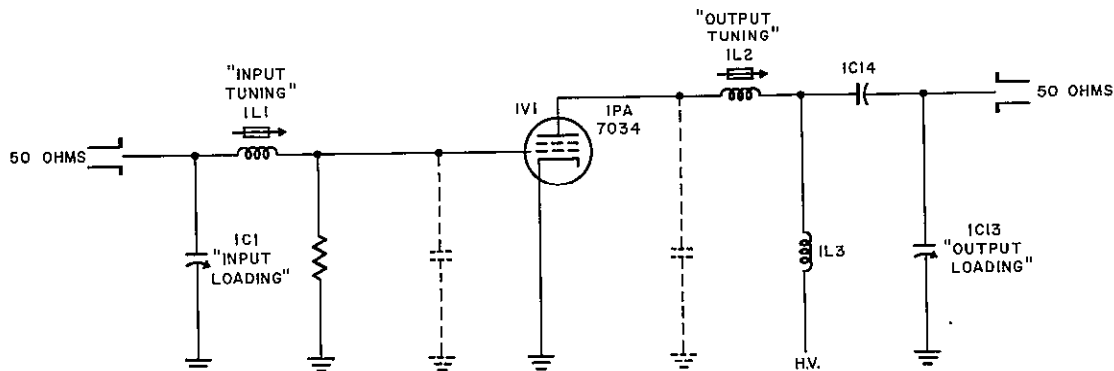

Figure T-3. Simplified Schematic Diagram, Intermediate Power Amplifier

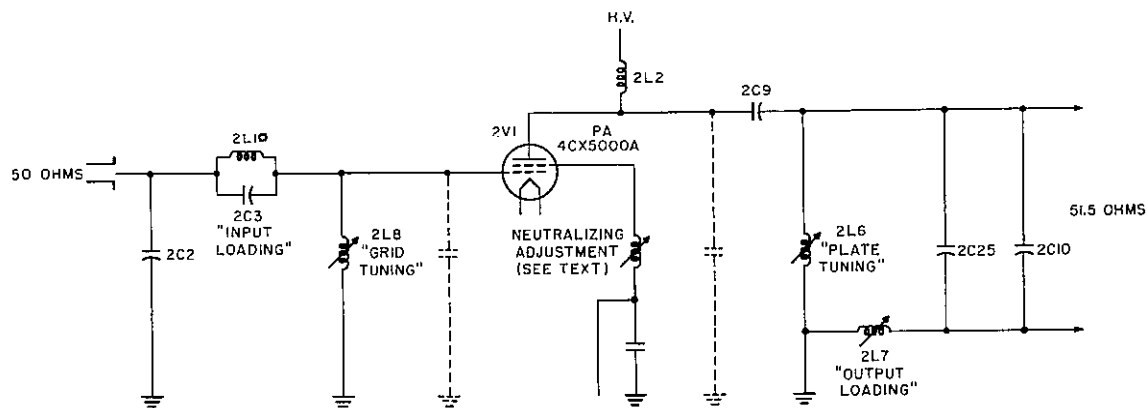

Figure T-4. Simplified Schematic Diagram, Power Amplifier

Power Supplies and Control Circuits

The power supplies and control circuits are shown on the overall schematic diagram of Figure 27. The high voltage supply is a 3-phase full-wave circuit utilizing six banks of silicon rectifiers. A single section, choke-input filter (2L3 and 2C21) supplies 6300 volts at approximately 2.3 amperes to the plate of the power amplifier (2V1). The half-voltage center tap of the high voltage transformer (2T1) supplies the plate of the intermediate power amplifier (1V1) through a double section r-c filter which effectively filters and at the same time reduces the voltage to approximately 2000 volts.

A second power supply utilizing germanium rectifiers (2CR1, 2CR2) in a bridge circuit, and a double section choke input filter (2L4, 2L5, 2C23, 2C24) supplies screen voltage to both the IPA and PA stages. The primary of this transformer (2T5) is fed from a motor-driven variable transformer (2T6) which provides manual control of screen voltage, and thus power output, for tune-up and other purposes. This SCREEN RAISE/LOWER control (2S12) is located on the front panel of the transmitter.

Power is applied from the 208/240-volt 3-phase line by the circuit breaker (2S1) located at the bottom of the right-hand vertical panel. From 2S1, power is fed to four other circuit breakers. The first of these breakers (2S3) is located at the bottom of the left-hand vertical panel and controls power for the blower, transmitter control circuits, amplifier filaments, transmitter exciter unit and the subcarrier generator (if used). Application of power to these circuits is controlled by the TRANS ON switch as described later. The second circuit breaker (2S2) is located at the base of the power amplifier compartment and controls power, through contacts of the plate contactor relay (2K9), to the plate transformer (2T1) and through the third and adjacently located breaker (2S4), to the screen supply transformer (2T5). The fourth circuit breaker (2S5) controls power through contacts of relay 2K15 to the blower (2B1). The filament line passes through buck-boost transformers 2T3 and 2T4 which permit exact adjustment of the line voltage to that required by the taps used on the primary of the filament transformers.

With all breakers turned ON and all door interlocks closed, power is applied to the various circuits of the transmitter by the TRANS ON and PLATE ON switches (2S10 and 2S9, respectively) mounted on the vertical panels. The TRANS ON switch (2S10) energizes relay 2K15 which starts the blower. Air passing into the IPA and PA compartments actuate vane-operated air interlocks (1S3 and 2S19),

energizing filament relay 2K11 which in turn applies power to the exciter, subcarrier generator, IPA and PA filament transformers (1T1 and 2T7) and to the 45-second time delay relay (2K4). This is evidenced by the lighting of the TRANS ON indicator (2DS4) on the front panel. After sufficient time has elapsed, contacts of time delay relay (2K4) close, completing the circuit through the closed door interlock switches (1S4, 1S1, 2S8, 2S6 and 2S7), through the normally closed contacts of the two-second time delay relay (2K7), through the stepping relay contacts (2K8) and the OFF FREQUENCY interlock relay in the exciter, up to the starting relay (2K10). This is indicated by the energizing of the READY indicator light (2DS3) on the front panel. Operation of the PLATE ON switch (2S9) then energizes 2K10 and the plate contactor relay (2K9) which in turn applies power to the high-voltage and screen-supply transformers and energizes the PLATE ON indicator light (2DS2).

Protective overload relays are installed in principal circuits throughout the transmitter as follows: Relay 2K1 is located in the ground return of the high-voltage rectifier. Relay 2K15 is in the cathode circuit of the power amplifier 2V1, and relay 2K6 is in the cathode of the IPA tube (1V1). Relay 2K5 is in the screen voltage supply.

Normally-open contacts on each of these relays are connected in series with the 2-second time delay relay (2K7). The closing of any of these contacts, as the result of an overload, energizes 2K7 which in turn opens the circuit to the plate contactor (2K9) and removes plate and screen voltages from the amplifier stages. At the same time another set of contacts on 2K7 energizes the 3-step relay (2K8) which advances one step and energizes the OVERLOAD indicator (2DS1). The second pair of contacts on 2K8, which are in the plate contactor circuit, remain closed. After a 2-second interval the time delay relay returns to its normal position which again energizes plate contactor 2K9 and applies plate and screen voltages to the power amplifier circuits.

If a second overload is present, the cycle repeats; relay 2K7 is again actuated, opening the circuit to 2K9 and advancing 2K8 to its second step position. In this position of 2K8, contacts in the OVERLOAD indicator and plate contactor circuits remain closed.

With a third such overload, however, stepping relay 2K8 is advanced to its final position, opening contacts in the plate contactor circuit. To restart the transmitter at this stage requires that the OVERLOAD RESET switch (2S11) be pressed. This energizes a second winding on 2K8 which returns the

relay to its normal position, closing the plate contactor circuit and opening the OVERLOAD indicator circuit.

The transmitter can be turned on and off by the TRANS ON (2S10) and PLATE ON (2S9) spring return key switches located on the front panel.

INSTALLATION

General

Basic steps in the installation of the RCA BTF-10D FM Transmitter consist of planning the equipment layout and making provisions for transmitter-room power and light, transmission line runs, and connections to the equipment. The units then can be unpacked, assembled and wired as specified in these instructions. Space for items not supplied, such as auxiliary input equipment, or line dehydrating units should not be overlooked in the planning. Before locating the transmitter, reference should be made to the instruction books supplied with these equipments.

NOTE: The instructions contained in these books are not intended to supersede applicable local codes. On points where conflict is evident, the local code should be followed.

A harmonic filter (MI-27967-1 or 2) is supplied with the BTF-10D transmitter and is designed to effectively attenuate second through seventh harmonic radiations from FM transmitters. The filter is constructed of coaxial transmission line and is the reflective type, i.e., the rejected energy is not absorbed. The filter is inserted in the transmission line at the top of the transmitter.

Electrically, each filter consists of an M-derived half-T section, several low-pass filter sections, and a constant-K, half-T section as shown in Figure 21. The M-derived section provides rapid cut-off in the second harmonic region, and a termination impedance at one end of the filter of 50 ohms. Attenuation of the harmonics is accomplished by the low-pass filter sections, while the constant-K, half-T section serves to give a termination impedance of 50 ohms at the other end of the unit.

In selecting a location for the transmitter, care should be taken to allow sufficient space for the filter which is approximately 10 to 12 feet in length (depending on frequency).

The room in which the transmitter is installed should be well ventilated and provided with an abundant supply of clean, dry air. The maximum ambient temperature for proper operation is given in the specifications. A transmitter room layout can be

prepared by reference to the floor plan diagram in Figure 24 (8616031), which gives the overall dimensions of equipment. A minimum clearance of 24 inches for the opening of doors is required at the front of the transmitter, and a similar space should be provided at the rear for access to transmitter components and circuits. Floor ducts can be installed for power wiring and remote control interconnection (if desired), or conduit may be run above the floor to the transmitter wire ducts at the base of the cabinets. If wiring is to be placed in floor ducts, the floor ducts should be laid out so that cables can leave the duct and enter holes provided in the bottom of the transmitter wire duct.

Most of the internal wiring of the BTF-10D has been completed at the factory prior to shipment. Since the exciter-driver and power amplifier cabinets are packed separately, it will be necessary to bolt these cabinets together and install the wiring cable interconnecting the two units. Other items to be installed are the exciter, subcarrier generator (if used), the high voltage plate transformer, blower and blower hoses. The 250-watt driver unit is shipped in the smaller of the two cabinets.

Unpacking

An understanding of the shipping system will be of assistance in unpacking the equipment and locating items. Each RCA equipment is accompanied by a shipping voucher which lists the complete contents of the shipment by "Equipment Schedule" or "ES" numbers and "Master Item" or "MI" numbers. This shipping voucher is usually packed in one of the smaller cardboard cartons, appropriately marked. Where there are two or more packages to a major item, the package containing the MI list is identified by stenciling.

The complete equipment for the BTF-10D FM Transmitter is listed on ES-34225 and ES-27278 which references the major items of the shipment and their MI number. These Equipment Schedules, together with the list of items contained on MI-34553 (Installation Material Kit) are reproduced in the front of this book.

The equipment should be carefully unpacked and inspected to make certain that no damage has been incurred during shipment. Any damage or shortages should be reported immediately to RCA and to the transportation company so that lost or damaged material can be recovered. Tubes should not be unpacked until all equipment is installed and all preliminary adjustments have been made.

Assembly

Reference should be made to the installation drawing, Figure 24 (8616031) which will aid in the assembly of the transmitter cabinets, and in the installation of the plate transformer (2T1), blower (2B1) and blower boot. Position the cabinets and bolt them together using the hardware supplied as items 22-D, H, J and N of the MI-34553 Installation Kit.

Place the plate transformer in position and make connections as shown in Figure 26.

NOTE: Due to the weight of the transformer it is unnecessary to bolt it to the floor.

After the plate transformer connections have been made, install and bolt the blower on the mounting pads as shown in Figure 13, and make the two connections to the blower motor terminals. Install the boot (item 9) contained in the installation kit (MI-34553) between the blower and the bottom of the PA cabinet, using the hose clamp and corner clamps supplied as item 8 with hardware items 22-A, F, and L. Also install the 2-inch hose through the hole in the cabinet wall, clamping one end to the outlet at the side of the PA compartment and the other to the inlet on the bottom of the IPA chassis. (Use the item 5 clamp of MI-34553.) Ascertain that the hose is clear of obstructions which would impede normal air flow. (See *Blower Adjustment* under OPERATION.)

Mount the front doors, end shields, logotypes and monogram, using the retainers supplied (MI-34553 items 1, 2, 3, and 4). The MI-28180-1 nameplate should be mounted on the top rear access panel of the amplifier rack.

Harmonic Filter Installation

Install the harmonic filter, MI-27967-1 or 2 as determined by the building layout, using the MI-19112-7 reducer. The filter should be located in a position which permits a reasonable amount of ventilation. Under no circumstances should the filters be located outdoors where "breathing" of the unit due to temperature changes may lead to condensation.

When installing the harmonic filter, refer to the Harmonic Filter *Technical Summary* and schematic diagram in Figures 20 and 21. Keep in mind the clearances necessary for the various size transmission line inner and outer conductors. Clearance of 1/8-inch must be allowed for each joint in all outer conductors. Inner conductors of 3/8-inch lines require a clearance of 3/16-inch at each joint, while inner conductors of 1 5/8-inch lines require a clearance of 1/8-inch at each joint. Ascertain that the harmonic filter is adequately supported from the ceiling to avoid excessive strain on the output line.

Once installed, the harmonic filter is ready for operation since it requires no tuning or adjustment.

The optional accessory equipment rack may be connected to the amplifier rack in the same manner as that employed for the driver rack. (Order ES-34211-A.)

R-F Monitor Assembly

To install the R-F Monitor Assembly (items 14 and 15 of MI-34553), connect the miter elbow (15) to the top of the output line. Position the r-f pickup saddle assembly over the hole in the side of the elbow so that the r-f pickup coil enters the hole without touching the sides. Position and secure the saddle clamps (MI-34553, item 5) around the elbow.

NOTE: The r-f pickup coil may be positioned for best signal pickup by removing the four screws which hold the coaxial connector in place and rotating it in either direction for maximum pickup (consistent with alignment of the mounting holes).

Equipment Wiring

Equipment wiring is accomplished by first making the interconnections between the transmitter cabinets and then making external connections between the transmitter and power source, and to any remote control circuits that may be used. Interconnections between terminal boards 1E and 2E in the cabinets are facilitated by a cable assembly supplied in the installation kit (item 27); connections to be made are specified on the connection diagrams of Figures 23 (8616018) and 25 (8616072). External connections are listed in TABLE I.

TABLE I. EXTERNAL CONNECTIONS

PLATE TRANSFORMER (Figure 26)	
	Terminals
Primary H1	2E75
H2	2E76
H3	2E77
Secondary R1	2E80
R2	2E79
R3	2E78
N	2E81
REMOTE CONTROL CONNECTIONS	
Remote Control Function	Terminals
Transmitter ON	2E25 — 2E26
Transmitter OFF	2E25 — 2E27
Plate OFF	2E28 — 2E30
Plate ON	2E29 — 2E30
Overload Reset	2E30 — 2E31
Power Output—Raise	2E23 — 2E25
Power Output—Lower	2E24 — 2E25

TABLE I. EXTERNAL CONNECTIONS
(Continued)

<i>Remote Meter Reading Function</i>	<i>Terminals</i>
PA Plate Voltage	2E34 — 2E36 (ground)
PA Cathode Current	2E33 — 2E36 (ground)
Power Output (2S13 in REMOTE)	2E35 — 2E36 (ground)
<i>External Overload Relay Connections</i>	<i>Terminals</i>
Relay 2K1	2E17 — 2E16 (common)
Relay 2K15	2E22 — 2E16
Relay 2K5	2E20 — 2E16
Relay 2K6	2E21 — 2E16
CRYSTAL HEATER VOLTAGE CONNECTIONS	
<i>Terminals</i>	
Located in IPA cabinet	1E4 — 1E5 (to 117 v-ac)
RF MONITOR CONNECTIONS	
Refer to RF Monitor under <i>ASSEMBLY</i> in the <i>INSTALLATION</i> section.	
POWER INPUT	
208/240 v a-c, 3 phase	Connect to terminals 2E72, 2E73 and 2E74

Transformer Primary Taps

The primaries of all filament and plate transformers, except 2T3, are provided with taps which permit operation of the equipment over a wide range of a-c line voltages. These taps are set at the factory for operation at a line voltage of 240 volts a-c. However, if the source line voltage is different, connections should be changed from the present taps to those designated for operation at the voltage closest to that measured.

NOTE: Transformer T113 in the exciter unit provides 117 volts between terminals 2 and 4. The black leads connected to these terminals should not be removed when adjusting the 230-volt line input taps. These black leads furnish power to the 117-volt primary of transformer T112. With these leads connected to terminals 2 and 4 of T113, the voltage supplied will be correct when the proper line taps on T113 have been connected to the source voltage.

The primary taps of all transformers are identified on the transformer and on the schematic diagram of Figure 27.

WARNING

BEFORE MAKING CONNECTIONS TO POWER CIRCUITS, ALL SWITCHES AND CIRCUIT BREAKERS SHOULD BE TURNED TO THE OFF POSITION TO

PREVENT POSSIBLE INJURY TO PERSONNEL, OR EQUIPMENT DAMAGE SHOULD POWER BE APPLIED ACCIDENTALLY TO THE CIRCUITS DURING INSTALLATION.

Remote Control Connections

The BTF-10D Transmitter may be remotely controlled by means of a BTR-11B or BTR-20A accessory Remote Control System. This system consists of an MI-27538-A Transmitter Control Unit and an MI-27537 Studio Control Unit for the BTR-11B System and the MI-27526 Transmitter Control and the MI-27539 Studio Control Unit for the BTR-20A System. The BTR-11B or BTR-20A may be connected directly to terminals in the BTF-10D to provide the remote control and remote meter reading functions shown in TABLE I. Designated terminals will be found on the 2E terminal board located in the larger cabinet and are indicated on the overall schematic diagram. All metering positions are designed to deliver approximately 1 volt into 5000 ohms.

Remote control of tower lights can be accomplished by utilizing an accessory Light Control Unit (MI-27519). Remote reading of the frequency and modulation monitor is accomplished by placing the monitor in the studio, and feeding an off-air signal into it through an antenna and r-f preamplifier which are also available as accessories.

After completion of wiring, check all connections for accuracy. Cover the wire duct openings by installing the wire duct covers using the hardware supplied. Place the blower circuit breaker (2S5), located at rear of large cabinet, in the ON position and replace the rear shield.

External Overload Connections

Terminals are available on terminal board 2E to facilitate the use of external overload relays. See TABLE I.

Preliminary Adjustments

The BTF-10D is shipped with an inductance strap (2L9) connected between the filament center tap of the 4CX5000A power amplifier tube and the ground side of the grid capacitors 2C28, 2C29 and 2C30. (See Figure 19.) The purpose of 2L9, which effectively parallels the grid circuit, is to extend the upper frequency limit of the grid tuning circuit. If the transmitting frequency is to be in the lower part of the band, i.e., between approximately 88 and 100 mc, remove 2L9 from the circuit. If operation will be in the range between 100 and 108 mc, do not remove 2L9 since it will be required for proper tuning.

Overload Relay Adjustment

Before power is applied to the transmitter, it is necessary to adjust the sensitivity of the overload relays 2K1, 2K5, 2K6 and 2K15, located inside the left-hand cubicle beside the PA compartment, so that they will pull-in at the current specified for each in TABLE II.

This can be accomplished by use of an ammeter of the proper range and a d-c supply which is adjustable from 0.5 to 1.5 volts and capable of delivering 2.5 amperes. An "A" battery, such as an RCA Type VS069, used with a series rheostat of between 5 and 10 ohms resistance, is a convenient supply for making this adjustment. Remove the relay covers with the rheostat set for minimum output voltage, connect the supply across the coil of the relay to be adjusted with the ammeter connected in series. Slowly increase the voltage to obtain the ammeter reading given in the table. Adjust the spring tension on the relay so that it just pulls in at the specified current. After adjustment, decrease and increase the current several times to check for proper operation. Replace the relay covers after adjustments have been made.

TABLE II. OVERLOAD RELAY SETTINGS

Relay	Circuit	Pull-in Current
2K15	4CX5000A Cathode	2.5 A.
2K1	H.V. Rectifier	3.0 A.
2K5	Screen Rectifier	300.0 MA.
2K6	7034 Cathode	250.0 MA.

Unpack and carefully install tubes and the exciter crystals in their proper sockets as directed in the Exciter Section of this book.

Blower Adjustment

The blower motor was adjusted at the factory for 60-cycle operation at elevations up to 2500 feet. For other conditions, adjust the blower motor as described

in the *Blower Adjustment Table* for 60-cycle or 50-cycle operation, respectively.

If the sheaves require adjustment, loosen the four (4) machine screws holding the motor to the base, then slide the motor toward the fan shaft to obtain sufficient belt slack for sheave adjustment.

Adjust either sheave by loosening the setscrew in the adjustable flange, and rotating the flange as specified in the Table. Sheaves can be positioned to either one of two positions 180° apart. Tighten the setscrew making sure the setscrew bears on the flat and NOT on the adjusting threads of the fixed flange.

After the sheaves have been adjusted, reposition the motor on the mounting base. Check the position of the motor to be sure the motor shaft is parallel with the fan shaft. Then tighten the four motor-mounting machine screws.

Check the belt slack, which should be $\frac{3}{4}$ " to 1" with the belt taut on the side opposite the measurement side.

Control Circuit Check

To insure that all connections have been made correctly, the following control circuit check should be made before installing tubes and applying plate and screen voltages to the transmitter.

1. Switch the following circuit breakers to the ON position: LINE (2S1) and FILAMENT (2S3) located on the front panel, and the blower circuit breaker (2S5) located in the rear of the cabinet. Leave the SCREEN and PLATE circuit breakers (2S4 and 2S2) in the OFF position. Replace panels and close all doors.

2. Operate the momentary contact TRANS ON/OFF switch (2S10) to the ON position. This should energize the filament transformers and time-delay relay. The blower should start at this time, and the TRANS ON indicator should go on as soon as the blower reaches operating speed. The READY indicator should light in approximately 45 seconds.

BTF-10D BLOWER ADJUSTMENT TABLE

Altitude Feet	Fan Speed R.P.M.	Fan Speed Inches W.G.	Fan Speed C.F.M.	60 Cycle		50 Cycle	
				Motor Sheave No. Turns Out	Fan Sheave No. Turns Out	Motor Sheave No. Turns Out	Fan Sheave No. Turns Out
SEA LEVEL	2820	3.0	315	5½	0	2½	2½
2500	2950	3.3	327	5	½	2	3
5000	3200	4.3	361	4	1½	1	4
7500	3400	4.6	395	3	2½	½	5

3. Turn the LINE switch (2S15) on the front panel to each of its four positions while reading the voltage for each on the AC VOLTMETER (2M5). The voltage readings in each of the four positions should be approximately that for which the transformer taps are adjusted. With the LINE switch in the FIL LINE position, adjust the FIL LINE control, if necessary, to bring the line voltage reading closest to the value for which the taps on filament transformers 1T1 and 2T7 are set.

4. Switch circuit breakers LINE and FILAMENT to the OFF position.

Tube Installation

Insert the 7034 and 4CX5000A tubes in their respective sockets. The fit of the 4CX5000A PA tube in its socket is very tight (see Figure 16) and special attention should be given to its installation to ascertain that it is properly seated. Proper seating can be determined by observation; the top of the screen ring will be flush with the top of the screen contact when the tube is seated against the stops. Reference should be made to the special instructions stenciled on the inside of the r-f compartment door.

TUNING

RECOMMENDED MEASURING EQUIPMENT

(In addition to equipment listed in the Exciter Section)

1. Directional Coupler (M. C. Jones Type 576N6 for use with external meter, or Type 706N with built-in meter).
2. IPA dummy load (M. C. Jones 636N).
3. PA dummy load (RCA MI-19193L).

The initial tuning procedure consists of adjustments to be made to the exciter and subcarrier generator, adjustment of the IPA and PA screen voltages and adjustment of the PA neutralizing circuit. Instructions for tuning-up the exciter and subcarrier generator are contained in the instruction book supplied with the units (IB-30262). (Exciter data also contained in the Exciter Section of this book.

Presetting of Controls

The tuning and loading controls of the IPA and PA stages must be preset to their approximate tune-up positions as given in the following steps and with reference to the IPA and PA tuning curves:

1. Set the IPA INPUT LOADING (1C1) and OUTPUT LOADING (1C13) capacitors to their half open positions. Set the INPUT TUNING (1L1) and

OUTPUT TUNING (1L2) controls to the dial positions given in Figure 5, for the frequency to be used.

2. Set the PA GRID TUNING (2L8) control to the dial position given in Figure 6 for the frequency to be used; and set the GRID LOADING (2C3) control for a dial reading of 35.

3. Set the PLATE TUNING (2L6) control and the PLATE LOADING (2L7) control to the respective dial positions given in Figure 7 for the frequency to be used.

PA Neutralizing Adjustment

Neutralization of the PA circuit is obtained by the correct positioning of eight angular slides located in guide slots at the four corners of the PA tube base. (See Figure 18.) In making this adjustment, reference should be made to the curve of Figure 8, which gives the proper setting of these slides for the frequency to be used. As indicated on the curve, measurements are made from the outer edge of the slide to the outer ends of the guide slots. For example, if operation is to be on 88 mc, the eight slides should be positioned at the outer ends of the slots, i.e., at the farthest point from the tube base. It will be necessary to remove the PA tube to adjust the rear slides. After these slides are adjusted in accordance with Figure 8, the PA tube can be replaced. Adjustment of the slides for the frequency to be used, in accordance with Figure 8, normally provides complete neutralization, and no further adjustments are necessary.

CAUTION: Ascertain that the PA tube is properly seated in its socket. See Figure 16.

Exciter Warm-Up

Adequate warm-up time for the exciter circuits must be allowed before tuning adjustments can be made. To energize the exciter circuits proceed as follows:

1. Switch the FIL OVERLOAD (S104) and PLATE OVERLOAD (S103) breakers located on the exciter chassis to the ON position.

2. Apply 117 volts a-c power to the crystal heater circuits of the exciter. The crystal heater indicator lights DS101 and DS102 should light and remain lighted until the crystal heaters have reached operating temperature.

3. Switch circuit breakers LINE (2S1) and FILAMENT (2S3) to the ON position, and turn the TRANS ON/OFF switch to the ON position. This will apply a-c power to the exciter circuits.

Allow approximately ten minutes warm-up time and then proceed with the exciter tune-up as described in the Exciter Section of this instruction book.

Amplifier Tuning

With the exciter tuned as previously described, and PA neutralizing adjustments completed, the screen voltage should be adjusted and final tuning of the transmitter accomplished in accordance with the following procedure:

1. Place exciter circuit breakers FIL OVERLOAD (S104) and PLATE OVERLOAD (S103) in their OFF positions.
2. Switch the circuit breakers LINE (2S1), FILAMENT (2S3), PLATE (2S2) and SCREEN (2S4) to their ON positions.
3. Operate the TRANS ON/OFF switch (2S10) to the ON position. Before proceeding with the next step, allow 30 minutes warm-up time to permit the 8008 high voltage rectifiers to vaporize mercury deposits.
4. Operate the SCREEN RAISE/LOWER switch (2S12) to the LOWER position and hold this position until the motor (2B2) reaches the end of its travel. This should be the zero screen voltage setting.
5. Turn the MULTI-METER switch (2S14) to the SCREEN 0-500V position.
6. Operate the PLATE ON/OFF switch (2S9) to the ON position.
7. Operate the SCREEN RAISE/LOWER switch to the RAISE position to bring the screen voltage to approximately 200 volts as read on the MULTI-METER. At this setting the PLATE CURRENT meter (2M1) should indicate 0 plate current.
8. Turn the MULTI-METER switch to the SCREEN 0-1000V position and read the PA screen voltage on the MULTI-METER. This should read approximately 520 volts.
9. Operate the PLATE ON/OFF switch to the OFF position.
10. Switch the exciter circuit breakers FIL OVERLOAD (S104) and PLATE OVERLOAD (S103) to the ON positions, and allow a few minutes time for warm-up.
11. Operate the PLATE ON/OFF switch to the ON position.
12. Turn the MULTI-METER switch to the GRID 0-50 MA position, and adjust the IPA INPUT TUNING and INPUT LOADING controls for maximum grid current reading on the MULTI-METER.
13. Turn the MULTI-METER switch to the GRID 0-100 MA position, and adjust the IPA OUTPUT TUNING and OUTPUT LOADING controls for maximum grid current. Make a note of this reading.

14. Set the PA GRID LOADING control so that the dial reads 30, and readjust IPA OUTPUT LOADING and OUTPUT TUNING for maximum PA grid current as read on the MULTI-METER. If this reading is higher than that obtained in Step 13, decrease the GRID LOADING slightly, and again tune the IPA loading and tuning controls for maximum grid current; repeat until maximum grid current is obtained. If the grid current obtained with the dial set at 30 was lower than the reading noted in Step 13, repeat the above procedure by increasing the dial setting rather than decreasing, until maximum grid current is obtained. (See Figure 6 for 2L8 setting.)

NOTE: IPA Output/PA Input Tuning—Interaction between the output of the 7034 IPA stage and the input of the 4CX5000A PA stage results in power transfer over a wide range of control settings.

The most efficient setting is obtained when the following conditions prevail:

1. The coaxial cable connecting the two stages is terminated in its 50 ohm characteristic impedance.
2. No reactive energy circulates between the two stages.
3. No hot spots occur along the cable.
4. The circulating current in the 7034 stage is at a minimum, and the circuit runs cooler.

To check transmitter tuning for proximity to the proper setting, the following procedure is recommended:

1. Reduce the 4CX5000A screen voltage to 400 volts. Turn off the transmitter power and remove the r-f cable from the output of the 7034 stage at the rear of the box (1J2). Note all readings.
2. Turn ON the transmitter power and tune the 7034 output tuning control (1L2) for maximum 7034 screen current. If the maximum occurs within one-quarter turn of the controls operating position, the transmitter is properly tuned.
3. If improper tuning is indicated, leave 1L2 in its new position, turn OFF the power and reconnect the r-f cable. Turn ON the power and retune the transmitter for power output by readjusting the 7034 loading and the 4CX5000A input loading and tuning.
4. Check the new tuning by repeating the above steps.

An alternate method of adjusting the circuit is to tune the 7034 stage into an r-f load, then tune the 4CX5000A input for maximum drive without retuning the 7034 stage.

If a directional coupler is available, a quicker and more accurate check can be made. This is done by placing the coupler in the line so that it indicates reflected power. The reflected power can then be adjusted to minimum under operating conditions.

15. Turn the reflectometer control to POWER position, and adjust the PA, PLATE TUNING and OUTPUT LOADING controls for maximum power output reading on the reflectometer. In adjusting these controls, operate them individually for maximum readings. As maximum reading is being reached, take each control past the maximum reading to where the reading drops about 5%. This will compensate for interaction of controls. Finally, controls should be peaked for maximum.

16. Raise screen voltage on PA to 700 volts. Touch up PA and IPA controls (in the reverse order from the initial tuning procedure) for maximum grid drive on both stages and maximum power output.

17. Now, adjust PA screen voltage for the rated 10 kw output. Refer to the PA Efficiency Curve, Figure 9.

NOTE: It is imperative that the power amplifier is operated under optimum matching conditions. To assure this condition turn PA LOADING one-half turn to left, repeak PA TUNING and read power output. Turn PA LOADING another one-half turn, repeak PA TUNING, read power and compare with previous reading. Repeat above steps and note whether power output increases or decreases. If it increases, keep going until a point is reached beyond which power is decreasing again.

Should power decrease, however, reverse procedure and make one-half turns of PA LOADING to the right.

During these adjustments the PA screen voltage should not be changed. Whenever the screen voltage is changed *more than* about $\pm 10\%$, PA LOADING and PA TUNING should again be optimized.

Power output of the transmitter is proportional to the screen voltage, but at a certain point, the output power will not increase further in spite of further increase in screen voltage. (See Figure 10.) Care should be taken not to operate beyond this point since PA efficiency will decrease rapidly if screen voltage is raised further. With sufficient drive, the tapering-off should occur at an output in excess of 10 kw at screen voltages of 800 V or more. However, insufficient drive may cause this point to shift to power levels less than 10 kw and lower screen voltages.

With the transmitter tuned and adjusted for 10 kw output, and the reflectometer switch (2S13) in the POWER position, the reflectometer (2M3) should be adjusted to read 100%. This is obtained by adjustment of the potentiometer 2R14. 2R14 is the left-hand one of two potentiometers located on a panel below the overload relays. The right-hand potentiometer is 2R15 which is used for adjustment of the remote meter with 2S13 in the REMOTE position.

TABLE III. TYPICAL "MULTI-METER" READINGS

Position of "MULTI-METER" Switch	Reading
OFF	0
<i>7034</i>	
GRID 0-50MA	9.5 ma (approx.)
CATHODE 0-500MA	220 ma (approx.)
SCREEN 0-50MA	7 ma (approx.)
SCREEN 0-500V	250 to 300 vdc
<i>4CX5000A</i>	
GRID 0-100MA	40 to 50 ma
SCREEN 0-500MA	50 to 140 ma
SCREEN 0-1000V	700 to 800 vdc

To read transmission line VSWR on the reflectometer, proceed as follows:

1. Turn reflectometer switch, (2S13) to VSWR CAL position, and adjust the reflectometer control (2R13) until the reflectometer reads 100%.
2. Switch reflectometer switch to VSWR position, and read directly on VSWR scale of reflectometer.

After the necessary adjustments have been made for the correct reading of the reflectometer, operate the PLATE ON/OFF control to the OFF position.

At this point the PA circuit can be checked for proper neutralization in the following manner:

1. Remove resistor 2R9 plate resistor from its mounting clips, and disconnect the 4CX5000A screen lead from feed through capacitor 2C11. See Figure 13 for the location of these components.
2. With a dummy load connected to the transmitter output, operate the PLATE ON/OFF switch to the ON position. Measure the power output of the transmitter with the SCREEN RAISE/LOWER switch adjusted to provide 300 volts on the screen of the 7034 driver tube. If the power output is greater than three watts, further adjustments of the neutralizing slides at the front of the PA tube will be required until the power output is not more than two or three watts.

WARNING

MAKE CERTAIN THAT THE PLATE CIRCUIT BREAKER (2S2) IS IN THE OFF POSITION BEFORE MAKING ANY ADJUSTMENTS INSIDE THE TRANSMITTER.

3. Disconnect the dummy load and connect the transmission line to the output of the transmitter.

OPERATION

In normal transmitter operation, the circuit breakers LINE (2S1), FILAMENT (2S3), SCREEN (2S4) and PLATE (2S2) should be left in the ON position and the crystal heaters left running continuously, unless the transmitter is to be shut down for extended periods of time. This way, it is possible to start and stop the transmitter by operating only the filament and plate circuit switches TRANS ON/OFF (2S10) and PLATE ON/OFF (2S9), respectively.

To interrupt transmission for a short interval, the PLATE ON/OFF switch should be depressed to its OFF position. This will remove plate voltage from the transmitter circuits but the filament power will remain on the tubes. The transmitter can then be returned to immediate operation when the PLATE ON/OFF switch is again closed.

NOTE: One button control of the transmitter may be achieved by leaving the PLATE ON/OFF switch in the ON position and operating the filament ON/OFF switch. Operated in this manner the transmitter will automatically go through the necessary starting steps including time delay relay operation.

Normally, the time delay relay provides sufficient warm-up time (approximately 45 seconds) after which plate voltage can be applied. The crystal heater units, from a cold start, require several minutes warm-up time before the transmitter is operated.

If the exciter is off-frequency for any reason, the off-frequency interlock prevents application of plate voltage, by opening the circuit to the plate contactor (2K9).

Performance of the FM exciter can be checked by observing the patterns on the built-in oscilloscope while the transmitter is on the air. For typical oscilloscope patterns refer to Figure 7 in the Exciter Section of this book. These oscilloscope patterns may be observed during regular operation without affecting performance of the transmitter.

Overload Resetting

If an overload occurs, plate power will be removed from the transmitter. After the cause of the overload has been corrected, operate the OVERLOAD RESET switch (2S11) on the front panel to place the transmitter back on the air.

MAINTENANCE

With ordinary care a minimum of service will be required to keep the BTF-10D in operation. However, a regular schedule of inspection and service as outlined in the Maintenance Schedule will help to avoid interruptions to broadcasts, greatly extend the life of

components and contribute in large measure to overall peak efficiency in operation.

WARNING

ALWAYS OPEN THE LINE CIRCUIT BREAKER, AND DISCHARGE CIRCUITS WITH A GROUNDING STICK BEFORE TOUCHING ANY COMPONENT INSIDE THE TRANSMITTER.

Emergency Operation

Tube or component failure can be located in some cases by switching the MULTI-METER switch (2S14) on the front panel and the METER switch (S102) in the exciter to each of their positions until an abnormal reading is found, identifying the difficulty.

Failure of automatic frequency control due to a tube or other component will be evidenced by operation of the relay K101 in the exciter off-frequency control circuit which will open the plate contactor circuit of the transmitter, removing plate voltage. If the master oscillator is functioning, the output carrier frequency can be controlled manually as follows until such time as repairs can be made:

1. Remove the 2D21 OFF-FREQUENCY control tube (V116).
2. Turn the AFC-OFF switch (S101) to the OFF position.
3. Slowly rotate the top adjustment screw of T103 in first one direction and then the other to bring the output frequency to its assigned value as indicated by the station frequency monitor.

Stability of the master oscillator without afc is such that it maintains frequency to ± 1 kc (at the final frequency) for short periods of time. Possible drift can be corrected by adjustment of the top screw of T103.

NOTE: The voltage of the filament d-c power supply in the exciter will vary with load. Therefore, care should be taken not to remove more than two of the tubes having d-c on the filament. Otherwise, damage to the remaining d-c heated tubes or to C202 in the exciter unit may result.

Emergency 4CX5000A Plate Lead

If necessary, the teflon plate lead for the 4CX5000A PA tube can be replaced by a length of RG-58/U coax cable with the outer cover and braid shielding removed.

Troubleshooting Hints

NO PA DRIVE — Check the coax cable and connections between the IPA and PA (1J2-1P2 and 2P1-2J1) for continuity and for hot spots. The cable

should be near ambient temperature. Examine capacitors 2C4, 2C15 and 2C33 for hairline cracks. If cracks are found, the capacitor is defective and should be replaced.

Cleaning

Ceramic insulators and bushings should be kept clean at all times. Insulators subject to stress in high-voltage d-c fields may rupture if sufficient dust accumulates to cause a corona discharge. Clean insulators by using a soft clean cloth and Chlorothene.*

Circuit Breakers and Relays

Periodic inspection of circuit breakers and relays should be made, and at such time, contacts should be cleaned and adjusted if necessary. Relay contacts should be cleaned with Chlorothene applied with a soft brush, after which they should be burnished with a tool such as the RCA Stock No. 22963, Contact Cleaning Tool. Finally, contacts should be wiped with a clean piece of bond paper.

Tubes

All tubes should be checked periodically. Tube failure can be anticipated by keeping a log of tube life, and replacing tubes as indicated by the log or when reduced output is apparent.

Silicon Rectifiers

The condition of the silicon rectifiers may be checked by measuring the resistance of each cell of the high voltage rectifiers with an ohmmeter. The forward resistance of each cell should measure approximately 25 ohms while the reverse resistance should measure 20,000 ohms $\pm 5\%$. Unless the reverse resistance reading of a cell is abnormally low, the 22,000 ohm resistor shunting each one need not be disconnected. The condition of an entire cell bank may be checked simply by measuring the resistance of one cell as directed above, then multiplying this value by the number of cells in the bank. Measure the resistance across the bank; if the measured total differs appreciably from the computed figure, one or more defective cells are indicated. To determine which cell (or cells) is defective, follow the above procedure for checking individual cells.

* Because of the toxic effects of carbon tetrachloride, the use of Chlorothene is recommended. Chlorothene is a Dow Chemical Co. Product, and is available through that company's outlets.

Recommended Maintenance Schedule

Daily

1. Check and compare all meter readings at start-up. Adjust filament voltages if necessary. Correct any conditions revealed by abnormal readings.
2. Check filament voltages every hour for increased tube life.
3. Make general visual inspection after shut-down.
4. If overloads have occurred, examine at shut-down, components involved. Repair or replace as necessary.

Weekly

1. Clean internal parts of transmitter. Use clean soft cloth on insulators. Use vacuum cleaner or hand blower for removing dust and dirt.
2. Test all door interlocks and grounding switches.
3. Check PA and output r-f circuits for evidence of heating at connector or junction points.
4. Make overall check of distortion and noise level.

Monthly

1. Check spare crystal in operating crystal socket.
2. Check condition of relay contacts. Service if necessary.
3. Check tube socket voltages in exciter. Compare with previous readings.
4. Inspect air filter. Clean if necessary, using vacuum cleaner or brush.

Quarterly

Lubricate tuning drive mechanism gears and bearings. Use petrolatum, Lubriplate No. 110, or equivalent.

Semi-Annually

1. Inspect relay contacts and replace where required.
2. Test spare tubes.
3. Tighten all connections in transmitter.

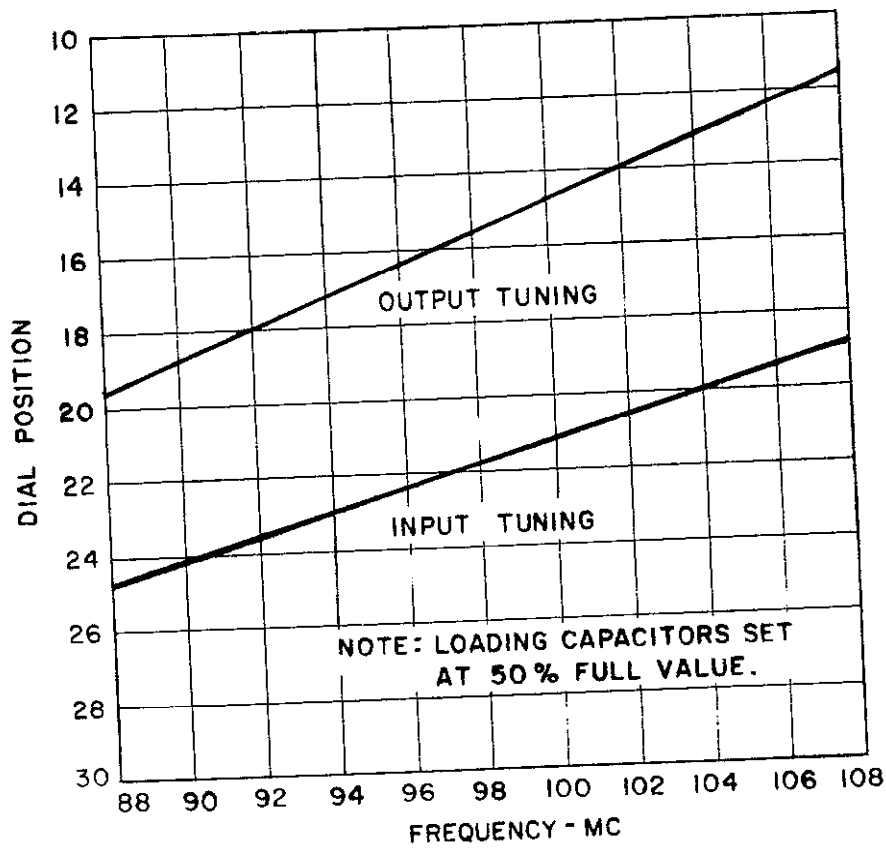

8988805-0

Figure T-5. IPA Tuning Curve

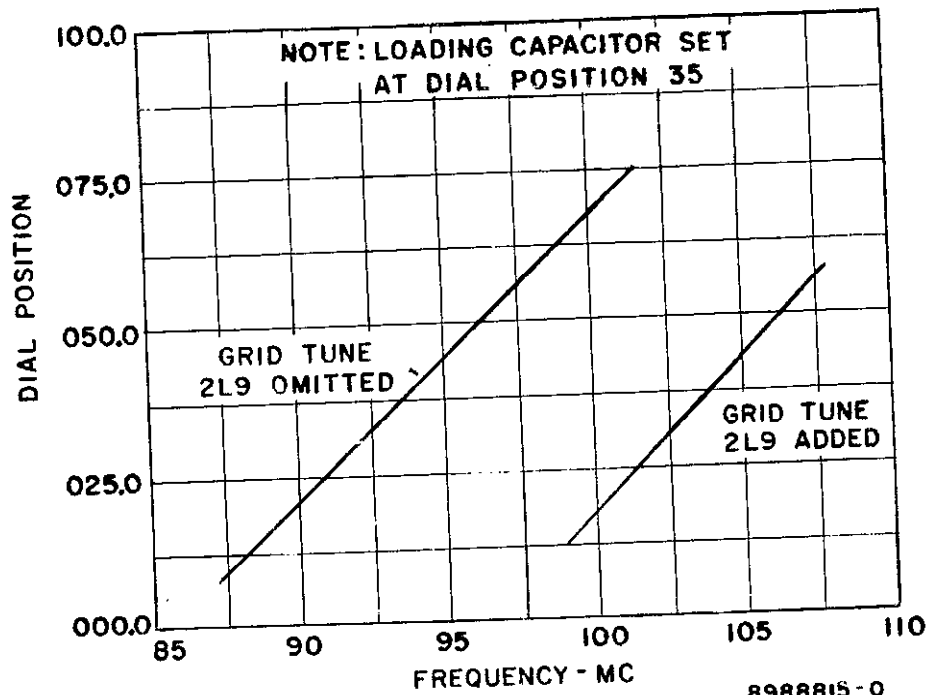

8988815-0

Figure T-6. PA Grid Tuning Curve (2L8)

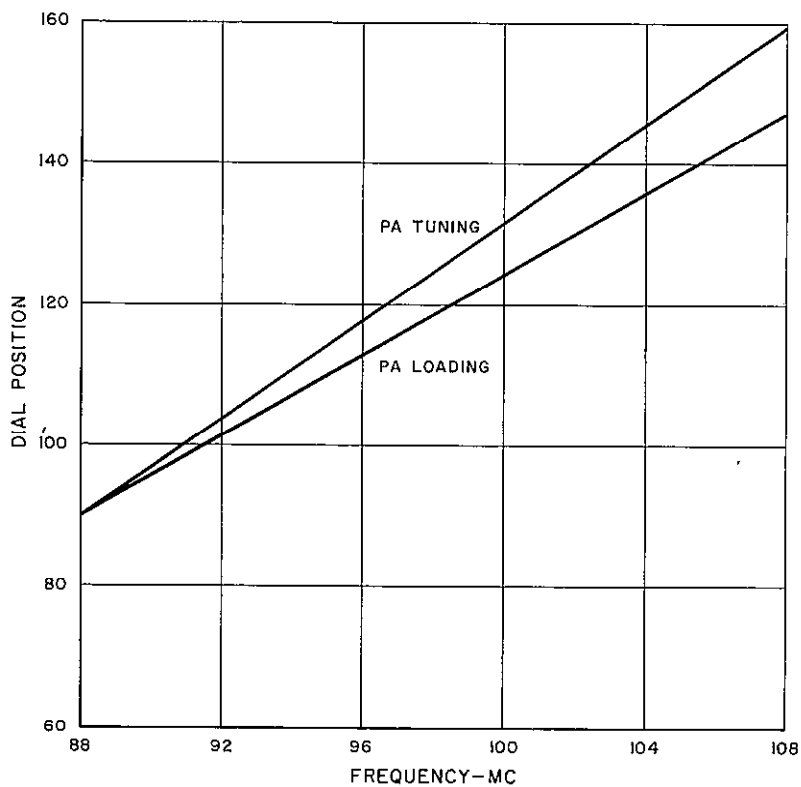

Figure T-7. PA Plate Tuning and Plate Loading Curve

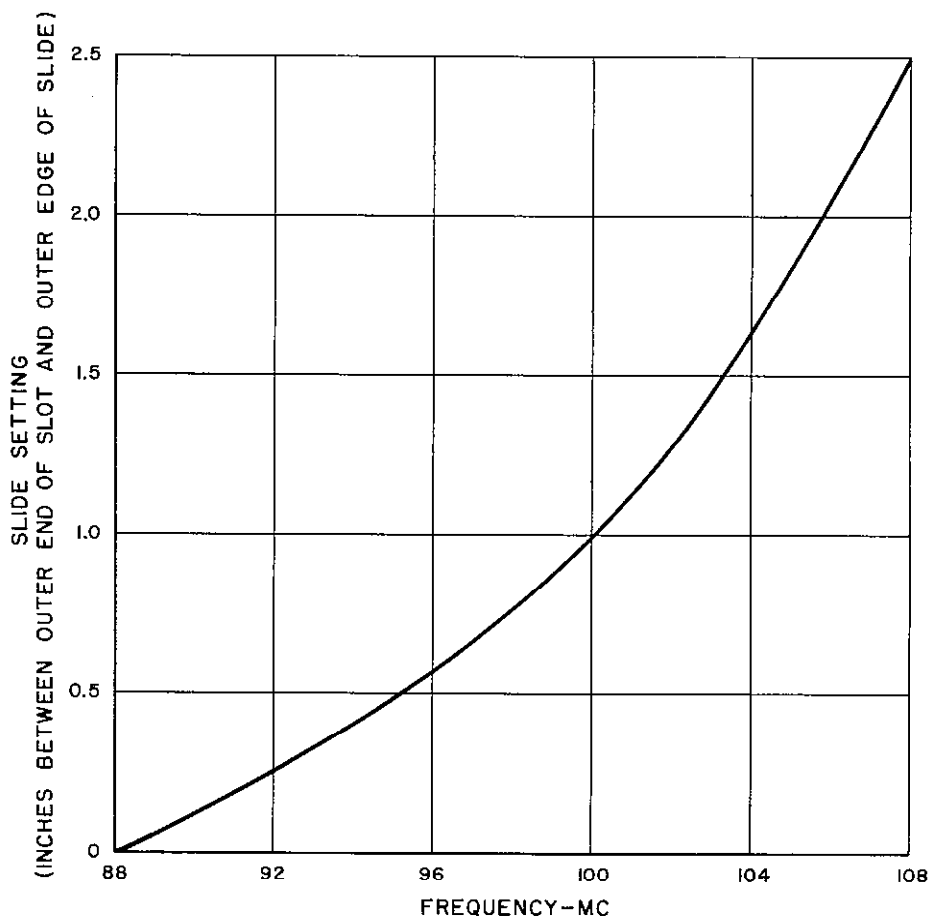

Figure T-8. PA Screen Neutralizing Adjustment

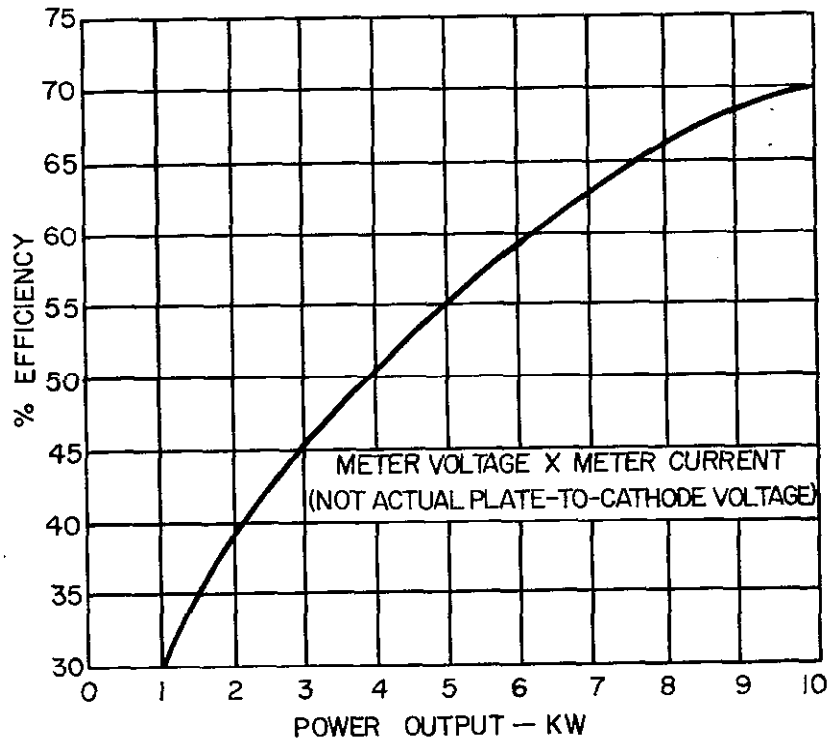

Figure T-9. PA Efficiency Curve

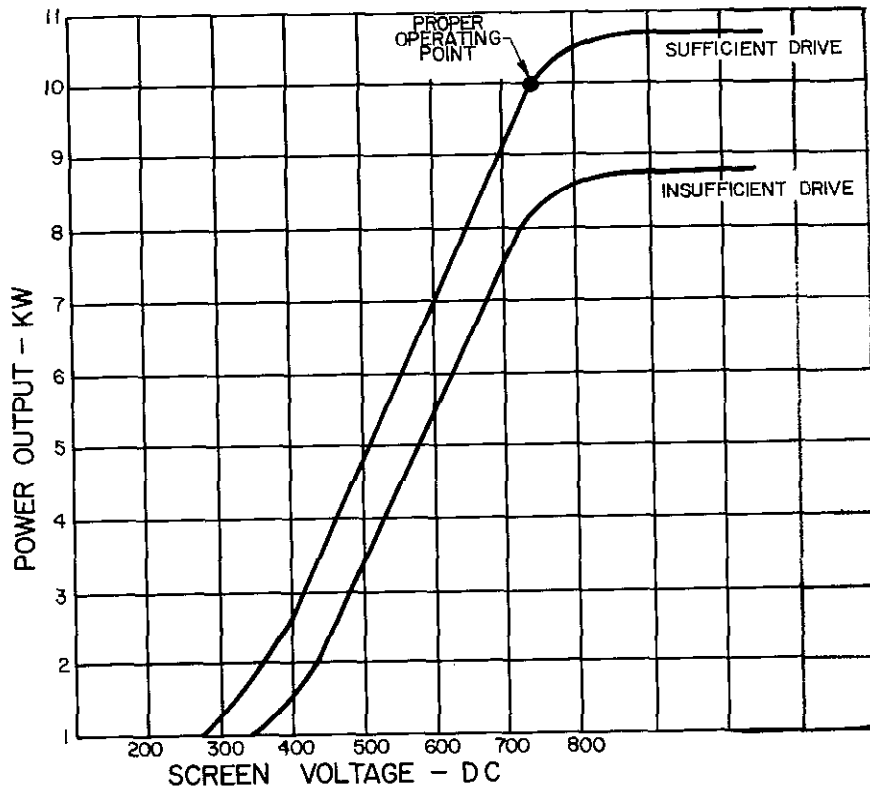

Figure T-10. Screen Voltage vs. Power Output Curve

LIST OF PARTS

Symbol No.	Stock No.	Drawing No.	Description
250 WATT R.F. UNIT, MI-34502-A			
1C1	217634	8971908-1	CAPACITORS: variable, 4.5-102 $\mu\mu\text{f}$
1C2	215859	8821367-1	HV ceramic, 25 $\mu\mu\text{f}$ $\pm 5\%$, 7500 v
1C3	217636	8825449-2	ceramic, feed-thru, 470 $\mu\mu\text{f}$ $\pm 20\%$, 500 v
1C4	95707	984002-361	silver mica, 1000 $\mu\mu\text{f}$ $\pm 10\%$, 500 v
1C5	217636	8825449-2	ceramic, feed-thru, 470 $\mu\mu\text{f}$ $\pm 20\%$, 500 v
1C6	95707	984002-361	silver mica, 1000 $\mu\mu\text{f}$ $\pm 10\%$, 500 v
1C7	217636	8825449-2	ceramic, feed-thru, 470 $\mu\mu\text{f}$ $\pm 20\%$, 500 v
1C8	95707	984002-361	silver mica, 1000 $\mu\mu\text{f}$ $\pm 10\%$, 500 v
1C9			Capacitor: (part of 1XV1)
1C10	95707	984002-361	silver mica, 1000 $\mu\mu\text{f}$ $\pm 10\%$, 500 v
1C11	217636	8825449-2	ceramic, feed-thru, 470 $\mu\mu\text{f}$ $\pm 20\%$, 500 v
1C12	221716	8889785-2	ceramic, feed-thru, 1000 $\mu\mu\text{f}$ $\pm 20\%$, 3000 v
1C13	217634	8971908-1	variable, 4.5-102 $\mu\mu\text{f}$
1C14	211186	479072-1	ceramic, 1000 $\mu\mu\text{f}$ -20 +40%, 2500 v
1C15 to 1C18	217636	8825449-2	ceramic, feed-thru, 470 $\mu\mu\text{f}$ $\pm 20\%$, 500 v
1J1, 1J2	92180	433647-1	Receptacle: female
1L1	217633	8956317-2	Coil: 3 turns 3/16 O.C. tubing, silver plated
1L2	217632	8956317-1	Coil: 4 turns, 3/16 O.D. tubing, silver plated
1L3	222952	8985525-501	Choke: R.F.
1P104	32661	878243-1	Connector: female
1P105	55808	727969-8	Connector: female
1R1		99126-69	Resistor: fixed, comp., 3900 ohms, $\pm 5\%$, 2 w
1R2	217635	8871557-63	Resistor: fixed, wire wound, 40 ohms, $\pm 1\%$, 2 w
1R3	96728	8857185-8	Resistor: fixed, wire wound, 200 ohms, $\pm 5\%$, 25 w
1R4	217615	8871557-64	Resistor: fixed, wire wound, 4 ohms, $\pm 1\%$, 2 w
1R5	210366	99033-38	Resistor: fixed, wire wound, 5000 ohms, $\pm 10\%$, 95 w
1R6	207818	99033-36	Resistor: fixed, wire wound, 3150 ohms, $\pm 10\%$, 95 w
1R7	217635	8871557-63	Resistor: fixed, wire wound, 40 ohms, $\pm 1\%$, 2 w
1R8		99126-51	Resistor: fixed, comp., 120 ohms, $\pm 10\%$, 2 w
1S1, 1S4	54920	8881052-1	Switch: interlock
1S2	217631	8953364-502	Switch: grounding
1S3	95677	8822758-2	Switch: airflow
	221810		Switch - only 250 v A.C.
1S5	216022	8953364-501	Switch: grounding
1T1	215512	8412123-1	Transformer: fil., single phase 208/240 v, 50/60 cy.
1XV1	215844	464586-2	Socket: air system
	99933	464586-3	Chimney only
	235219		Miscellaneous:
	96579	757412-506	Cable Assembly
	212885	146978-502	Connector - male coaxial
	211104	8905991-1	Connector - male coaxial
	215855	477946-502	Contact Assembly: front panel, horizontal mounted
	217665	8413444-502	Contact Assembly: front panel, vertical mounted
	94641	8822780-31	Hose: flexible, rubber 47 $\frac{1}{2}$ " lg. x 1 $\frac{1}{2}$ " I.D.
	219131	8914329-1	Receptacle: female, turnlock fastener
	223100	8510265-1	Screw: lead, teflon (for 1L1 and 1L2)
		8518085-501	Support Assembly
10 KW AMPLIFIER, MI-34554			
2B1		8616009-1	Blower - (MI-34556)
	221586	8616009-2	Motor - 3/4 H.P. 3450 RPM 230 V 50/60 cycles
	221587	8616009-5	Belt - drive
	221588	8616009-4	Pulley - 5/8" dia. bore
	221589	8616009-5	Pulley - 3/4" dia. bore
	221590	8616009-7	Mounting - Shock (See plate, stock no. 222330, below)
	222330	8989877-2	Plate - (order with 221590 shock mounts for early BTF-10C Transmitters only)
2B2	215552	480051-1	Motor: 115 v, 60 cycle
2C1	55018	863691-2	CAPACITORS: motor circuit, 1.2 μf , 220 v

*Nylon shaft
in tuning
assembly*

Symbol No.	Stock No.	Drawing No.	Description
2C2	214696	8821367-4	hi-voltage, 100 μmf $\pm 5\%$, 5000 v ceramic
2C3	217634	8971908-1	variable, 4.5-102 μmf
2C4	16.00 211186	479072-1	ceramic, 1000 μmf +40 -20%, 2500 v
2C5	221716	8889785-2	grid feed-thru, 1000 μmf $\pm 20\%$, 2000 v
2C6, 2C7	54643	8881825-1	fil. feed-thru, .01 μf $\pm 20\%$, 250 v
2C8	810004-4	36091-523	amp. meter by-pass 0.01 μf $\pm 20\%$
2C9	149 ³⁰ 25 ³⁴ 10 ⁴⁵ 217651	8973315-501	plate, by-pass
	217658	8436554-501	contact assembly
2C10	217653	8971927-2	ceramic, 50 μmf , 15,000 v
2C11	221716	8889785-2	grid feed-thru, 1000 μmf $\pm 20\%$, 2000 v
2C12			mica, 0.005 thk. test voltage 2000 v
	217645	8971914-1	mica only
2C13, 2C14	810004-4	36091-523	by-pass 0.01 μf $\pm 20\%$
2C15	211186	479072-1	ceramic, 1000 μmf +40 -20%, 2500 v
2C16	810004-4	36091-523	amp. meter by-pass 0.01 μf $\pm 20\%$
2C17, 2C18, 2C19	209037	990193-108	paper, 8 μf $\pm 10\%$, 3000 v
2C20	810004-4	36091-523	amp. meter by-pass 0.01 μf $\pm 20\%$
2C21	220328	990194-51	3 μf $\pm 10\%$, 7500 v (paper)
2C22			Not Used
2C23, 2C24	52758	990193-46	paper, 4 μf $\pm 10\%$, 500 v
2C25	217653	8971927-2	ceramic, 50 μmf , 15,000 v
2C26			Fil., by-pass
	217647	8708499-501	plate assembly
	17.95 217643	8971960-1	mica only
2C27			Fil., by-pass
	217647	8708499-501	plate assembly
	17.9 217644	8971960-2	mica only
2C28 to 2C30	211186	479072-1	ceramic, 1000 μmf +40 -20%, 2500 v
2C31	97151	8889035-2	ceramic, 390 μmf $\pm 10\%$, 8000 v
2C32, 2C33	211186	479072-1	ceramic, 1000 μmf +40 -20%, 2500 v
2C34	218954	8976374-1	paper, .001 μf , 10,000 v
2C35	219175	450184-4	paper, 10 μf , 400 v
2C36		990167-19	ceramic, 10,000 μmf +100 -0%, 500 v
2CR1, 2CR2	217866	8462374-1	Rectifier: single phase, center tap
2CR3, 2CR4			Not Used
2CR5, 2CR6	67876		Part of 2Z1 (1N21B)
2CR7	220285	8722935-502	Rectifier: low voltage (complete with diodes)
2CR8 to 2CR11	228078 218347	8720774-501	Rectifier: assembly
	14.30 11.74 11.00 218346	8438545-1	Rectifier: silicon (10 req'd. per assem.)
		8438545-2	Rectifier: silicon (10 req'd. per assem.)
2CR12 to 2CR17		8720774-502	Rectifier Assem.
	9.18 218347	8438545-1	Rectifier: silicon
		218346	Rectifier: silicon
2DS1		459610-10	Light: indicator overload
	99767	459610-33	Jewel - yellow
	16154	459610-36	Lamp
	16155	459610-40	Resistor
	99763	459610-46	Socket
2DS2		459610-8	Light - indicator plate on
	99765	459610-31	Jewel - red
	16154	459610-36	Lamp
	16155	459610-40	Resistor
	99763	459610-46	Socket
2DS3		459610-12	Light - Indicator interlock
	99768	459610-35	Jewel - Blue
	16154	459610-36	Lamp
	16155	459610-40	Resistor
	99763	459610-46	Socket
2DS4		459610-9	Light - Indicator filament
	99766	459610-32	Jewel - Green
	16154	459610-36	Lamp
	16155	459610-40	Resistor
	99763	459610-46	Socket
2J1	92180	433647-1	Receptacle: female connector
2K1	210404	754291-1	Relay - H.V. overload
2K2, 2K3			Not Used
2K4	215614	8411073-5	Relay - 45 sec. time delay filament
2K5	210404	754291-1	Relay - screen supply overload

Symbol No.	Stock No.	Drawing No.	Description
2K6	210404	754291-1	Relay: 7034 overload
2K7	217619	458561-8	Relay: 2 sec. time delay overload
2K8	216987	486126-2	Relay: notching
2K9	216989	482711-6	Connector: plate
2K10	216991	480003-4	Relay: plate latching
2K11	216988	8412197-1	Contactactor - filament
2K12	217606	627511-49	Contactactor - Control
2K13	216934	8412197-2	Contactactor - Blower
2K14	216991	480003-4	Relay - filament latching
2K15	210404	754291-1	Relay - 4CX5000A overload
2K16	217572	627511-55	Relay - Bias interlock
2L1			Not Used
2L2			Choke:- plate
2L3	95316	900431-4	Choke:- plate filter
2L4, 2L5	93658	949251-1	Reactor - 10 henrys
2L6 to 2L9			Part of plate tuning, plate loading, grid tuning assemblies and grid tuning inductor respectively
2L10		8976344-501	Coil: bus wire 3½ turns 1.06" O.D. 128" dia.
2L11	221173	8449712-1	Reactor - filter
2M1	217732	482744-10	Meter - plate 0-3 amps
2M2	220321	482744-32	Meter - plate 0-10 KV
2M3	217528	8436526-1	Meter - reflecto meter
2M4	217359	8959099-1	Meter - multiplier
2M5	216023	459672-129	Meter - line
2M6	217527	8971909-1	Meter - hour
			RESISTORS:
			<i>Fixed, Composition - Unless Otherwise Specified</i>
2R1	220324	993007-9	0.25 ohm, ±10%, 5 w
2R2			Not Used
2R3	217609	867971-327	wirewound, 3.6 ohm, ±10%, 1 w
2R4, 2R5	217652	8917168-2	150 ohm, ±5%, 70 w
2R6	54624	99031-31	1000 ohm, ±5%, 55 w
2R7	217616	8871557-65	wire wound, 20 ohm, ±1%, 2 w
2R8 to 2R10	204309	8888772-22	wire wound, 20 ohm, ±10%, 200 w
2R11	220319	8702674-512	Resistor assembly
	52819	8702674-3	resistors only 500,000 ohm ±1%, ½ w
2R12		90496-82	47,000 ohm, ±5%, 1 w
2R13	205064	433196-6	variable, 10,000 ohm, ±10%, 2 w
2R14	217618	433196-14	variable, 10,000 ohm, ±10%, 2 w
2R15	215733	433196-51	variable, 1000 ohm, ±10%, 2 w
2R16	217615	8871557-64	wire wound, 4 ohm, ±10%, 2 w
2R17	52819	8702674-3	0.5 megohm, ±1%, ½ w
2R18			Not Used
2R19	52819	8702674-3	0.5 megohm, ±10%, ½ w
2R20	217617	8871557-66	wire wound, 2000 ohm, ±1%, 2 w
2R21	216026	99037-47	wire wound, 40,000 ohm, ±10%, 200 w
2R22	220326	99037-36	wire wound, 3100 ohm, ±10%, 200 w
2R23	45983	99037-33	wire wound, 1600 ohm, ±10%, 200 w
2R24	220325	99037-32	wire wound, 1200 ohm, ±10%, 200 w
2R25	217612	99029-55	wire wound, .5 ohm, ±10%, 45 w
2R26 to 2R29			Not Used
2R30	52819	8702674-3	.5 meg, ±10%, ½ w
2R31, 2R32		90496-82	47,000 ohm, ±5%, 1 w
2R33	61011	867971-329	wire wound, 4.3 ohm, ±10%, 1 w
2R34	220327	8871557-56	940 ohm, ±1%, 1 w
2R35	211616	993007-100	9000 ohm, ±5%, wire wound, 5 w
2R36	48568	993008-81	1000 ohm, ±5%, wire wound, 10 w
2R37	220286	99029-36	3100 ohm, ±5%, 45 w
2R38	217608	993007-18	wire wound, 0.71 ohms, ±10%, 5 w
2R39	217614	8871557-53	wire wound, 1250 ohms, ±1%, 1 w
2R40		90496-50	100 ohms, ±10%, 1 w
2S1	220323	8434081-3	Breaker - 100 A
2S2	220322	8434081-2	Breaker - 70 A
2S3	217622	482740-5	Breaker - 15 A, 2 pole, 240 v, 50/60 cycle

Symbol No.	Stock No.	Drawing No.	Description
2S4	215946	482740-1	Breaker - 5 A, 2 pole, 240 v, 50/60 cycle
2S5	211742	8836936-11	Thermoswitch - overload (less heaters) heater only (style - 1532948)
2S6 to 2S8	54920	8881052-1	Switch: - interlock, 2 pole, 110 v, ac, 15 amps
2S9 to 2S12	211065	738998-5	Switch - key lever, power type, 1" F contact, 2 way
2S13	217607	426010-10	Switch - 1 sec., 5 pos. reflecto meter
2S14	217625	480092-3	Switch - rotary, 5 sec., 8 pos. multiplier meter
2S15	217621	4610205-8	Switch - rotary, 2 sec., 4 pos.
2S16 to 2S18	216022	8953364-501	Switch - Assembly H.V. grounding
	221848	8953366-501	Spring assem.
	220313	8953372-1	Contact
	210281	426767-9	Insulator
2S19		8822758-1	Switch: air flow, interlock
	221810		Switch
	221811		Vane - #1800
2T1	221266	8448402-1	Transformer - plate
2T2	215944	8415073-4	Transformer - control
2T3	212937	992085-1	Transformer - B.B.
2T4	96148	457084-1	Transformer - powerstat
2T5	215553	482736-1	Transformer - screen
2T6	96148	457084-1	Transformer - powerstat screen
2T7	217021	8411065-2	Transformer - 4CX5000A filament
2T8 to 2T13			Not Used
2T14	217550	8436506-1	Transformer - bias
2XV1	217037	644382-1	Socket - 4CX5000A consisting of:
	220957	644382-3	Contact - screen grid
	220958	644382-4	Contact - control grid
	220959	644382-5	Contact - outer filament
	220960	644382-6	Contact - inner filament
2Z1	220320	8434079-3	Coupler - Directional
			<i>Miscellaneous:</i>
	214657	885655-10	Bearing
	214658	188183-12	Bearing
	42736	99045-4	Clip - for .812" dia. ferrule
	52717	7862770-1	Clip - for 1-1/8" dia. ferrule
	211161	8904324-1	Contact
	217650	8971916-503	Contact Assembly - 2L8
	217646	8971915-501	Contact Assembly - screen cont cts, 4CX5000A
	217649	8971916-502	Screen Contact - 4CX5000A - 2L6/2L7
	57339	880947-1	Coupling - insulated
	215847	477962-1	Drive - right angle
	95160	888488-3	Filter
	97459	426763-3	Insulator - .425" lg. x 3/4" dia. steatite bushing
	217657	426771-12	Insulator - 1" lg. x 3/8" sq. post
	208116	426765-12	Insulator - 1" lg. x 3/8" dia. steatite, cylindrical
	97457	426767-3	Insulator - 1" lg. x 3/4" dia. steatite, cylindrical
	210281	426767-9	Insulator - 1-1/2" lg. x 3/4" dia. steatite cylindrical
	209711	426773-9	Insulator - 1-1/2" lg. x 3/4" sq. steatite square post
	209929	426773-12	Insulator: 2" lg. x 3/4" sq. steatite, square post
	51781-A	426762-6	Insulator - 1-1/2" lg. x 1" x 1/2" steatite, conical
	208116	426767-12	Insulator - 2" lg. x 3/4" dia. steatite cylindrical
	208005	426775-12	Insulator - 2" lg. x 1" sq. steatite square post
	99043	426762-9	Insulator - 2" lg. x 1-1/8" x 5/8" steatite conical
	215877	737820-505	Knob - for 2R13, 2S13, 2S14
	17269	737820-501	Knob - for 2S15
	58057	737820-506	Knob - for 2T4
	206706	8879208-2	Pad
	94641	8914329-1	Receptacle - Fastener
	217655	8944292-8	Screw - lead
	217654	8944292-7	Screw - lead
	98480	8886047-3	Washer - retaining
	99376	449642-28	Fastener only
	223103	8814044-2	Wire: teflon, silver coated 7/20 .285 O.D. (3" lg.)
INSTALLATION MATERIAL, MI-34553			
2CR12 to 2CR17		8720774-502	Rectifier Assembly

<i>Symbol No.</i>	<i>Stock No.</i>	<i>Drawing No.</i>	<i>Description</i>
	218347	8438545-1	Rectifier: silicon (3 req'd. per assem.)
	218346	8438545-2	Rectifier: silicon (3 req'd. per assem.)
	57077	887449-501	Arm - assembly, crank
	221127	8820789-4	Boot
	55913	8824489-8	Clamp - hose
	211286	8918002-501	Crank - assembly tuning
	53592	877065-1	Knob -(for crank assembly)
	223103		Cable - teflon (high voltage lead)

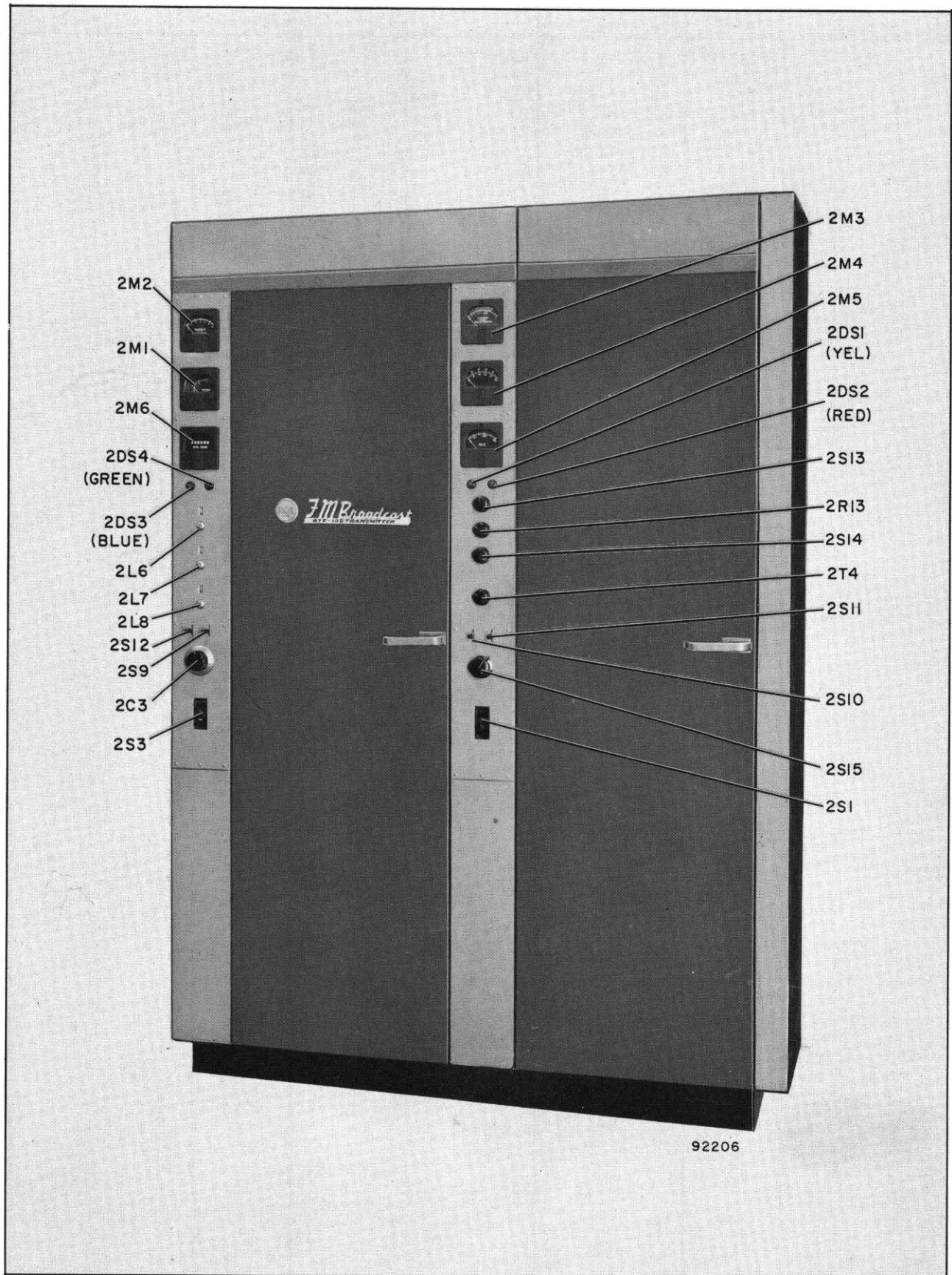

Figure T-11. BTF-10D FM Transmitter, Front View, Doors Closed

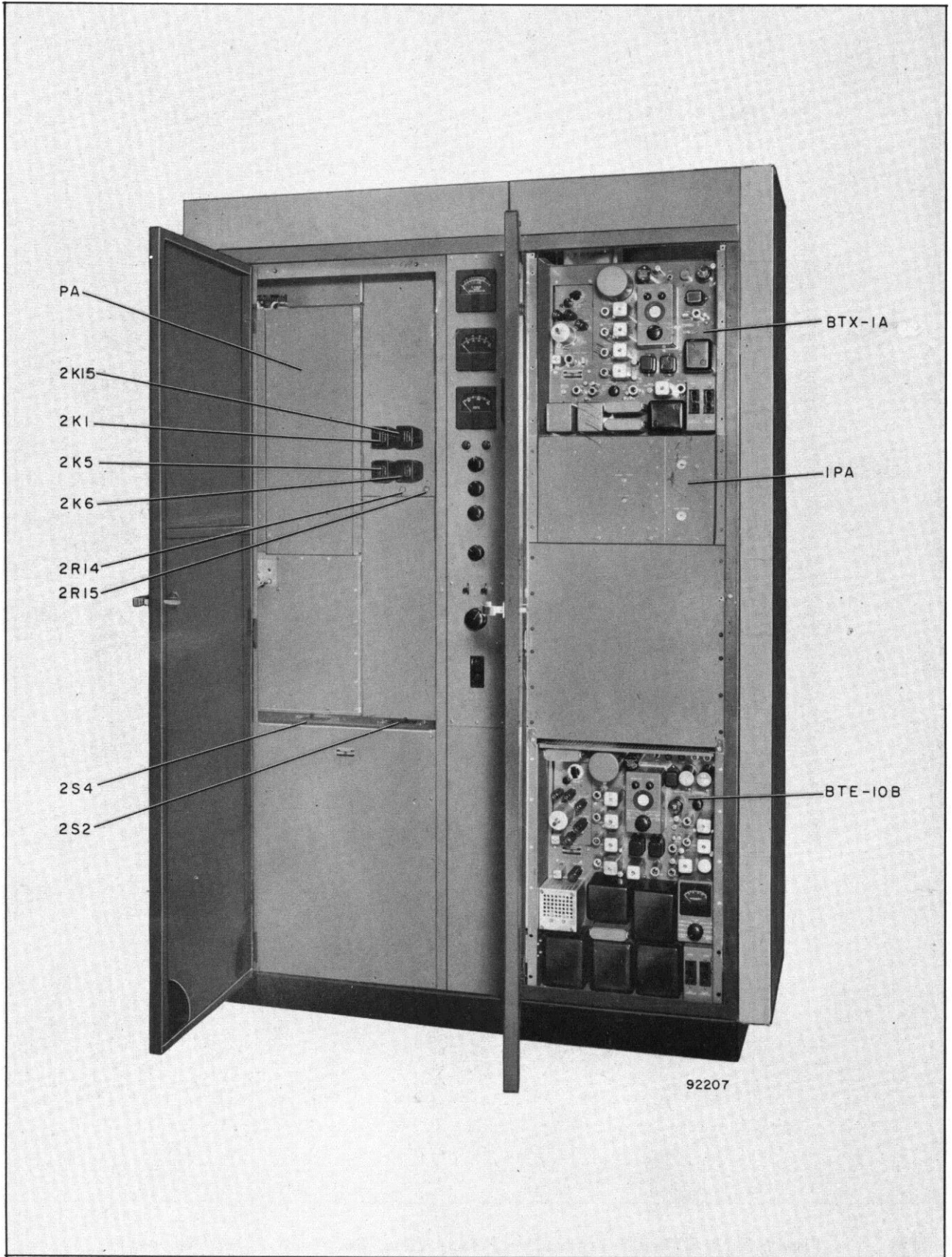

Figure T-12. BT-10D FM Transmitter, Front View, Doors Open

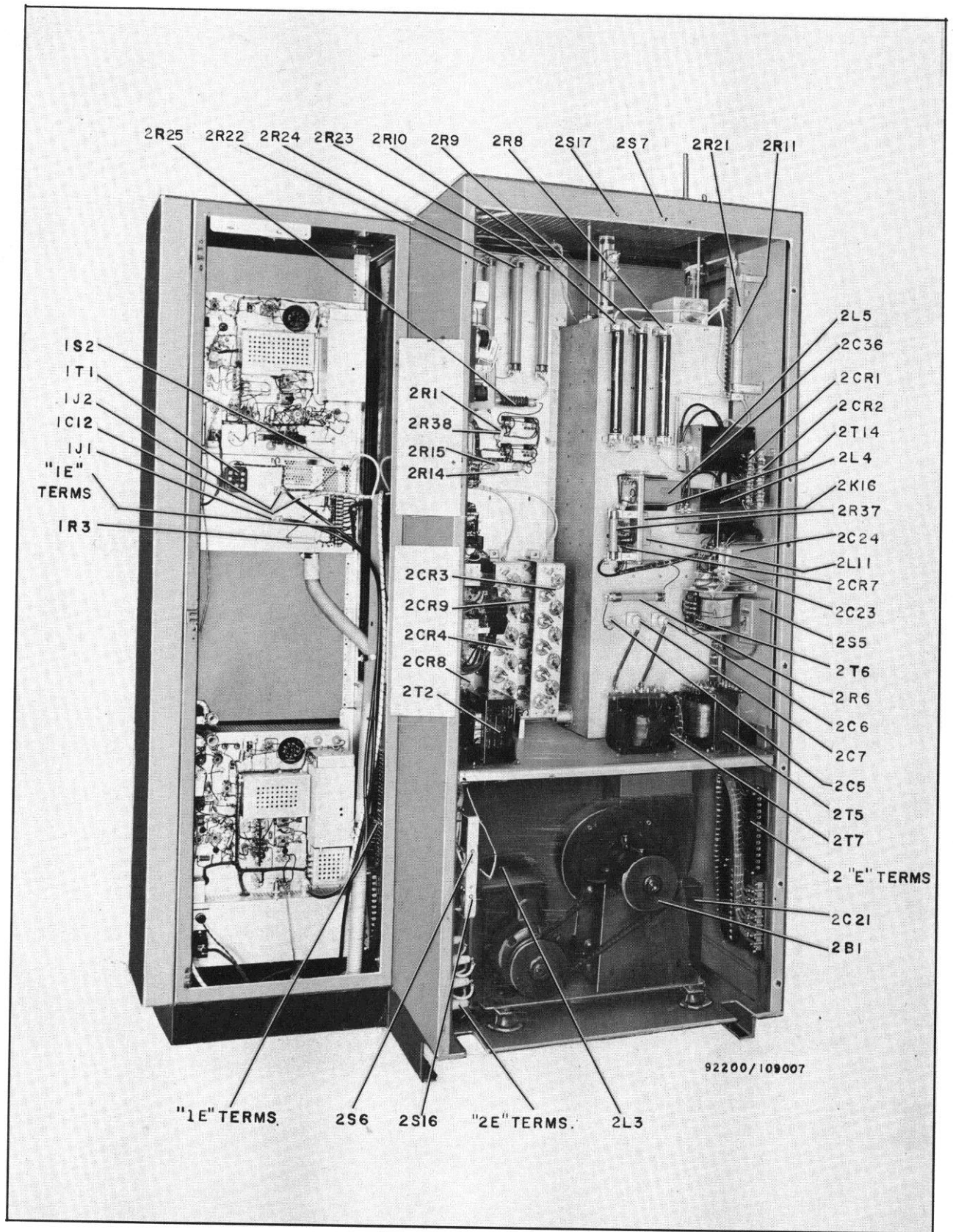

Figure T-13. BTF-10D Transmitter, Rear View, Door and Panels Removed

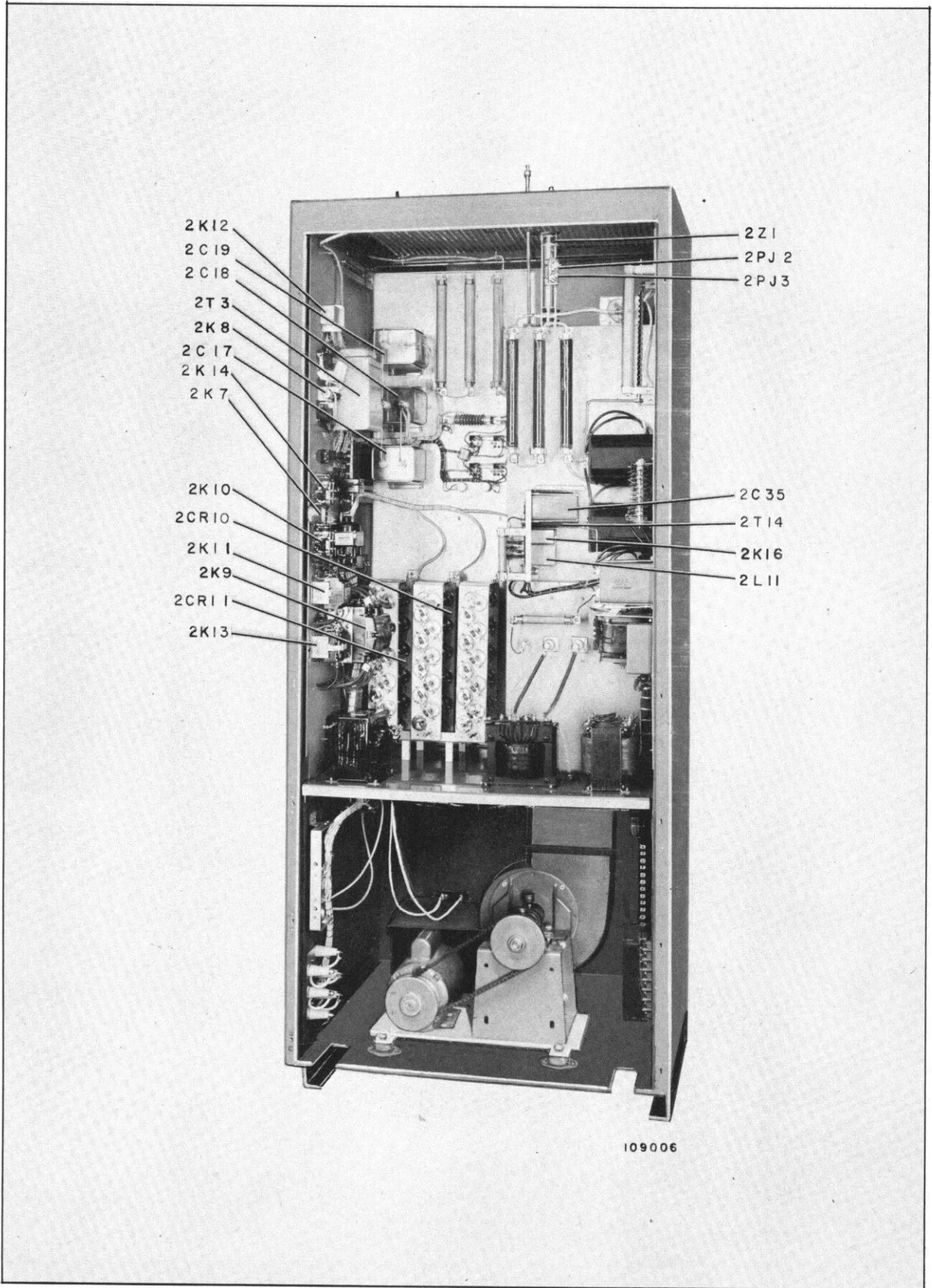

Figure T-14. BTF-10D Power Amplifier Cubicle, Rear View

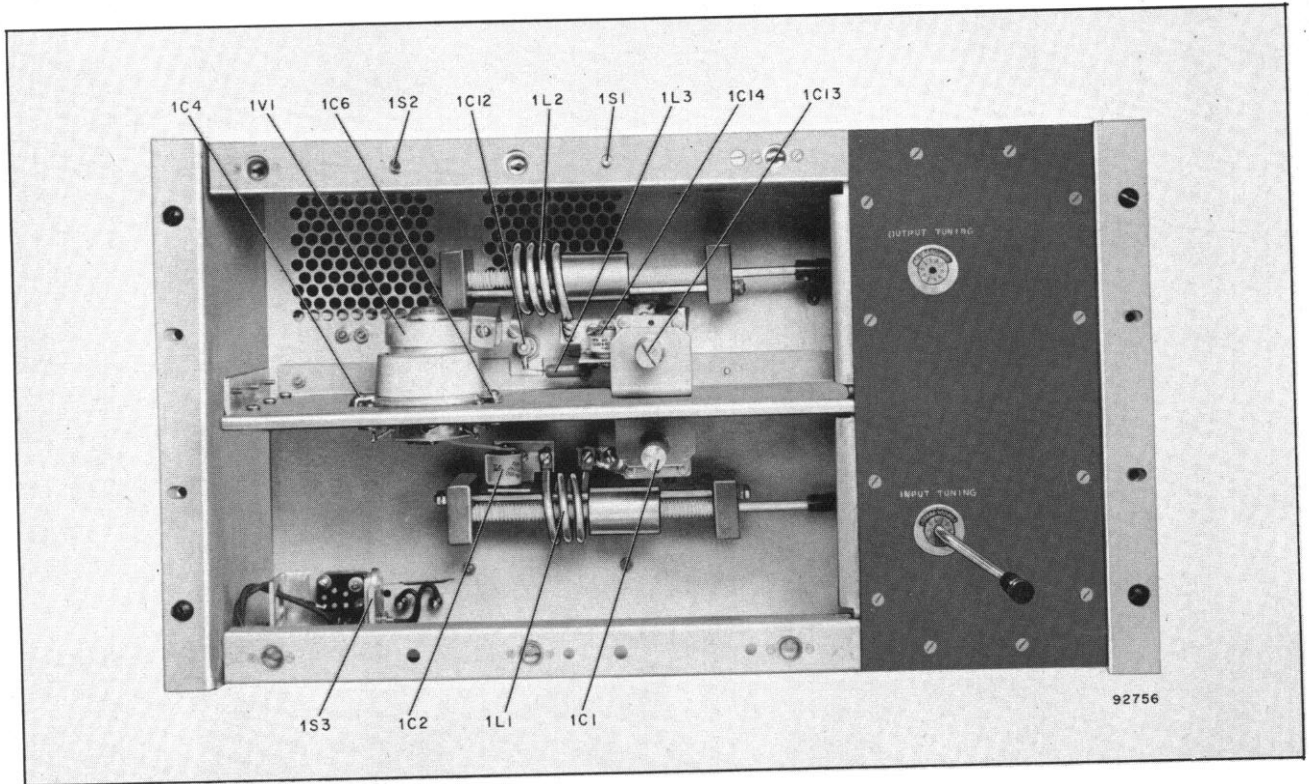

Figure T-15. BTF-10D 250-Watt IPA, Front Panel Removed

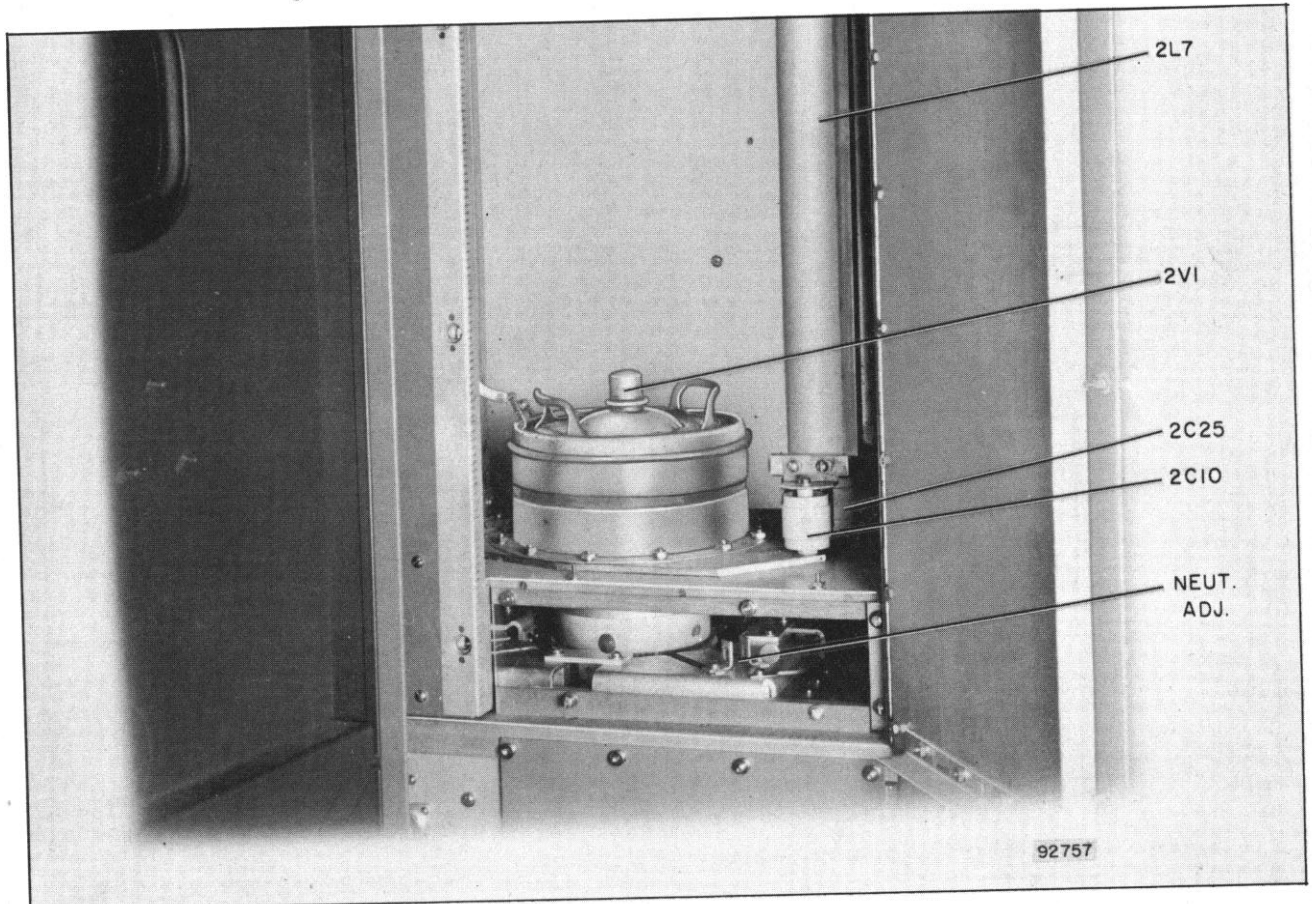

Figure T-16. BTF-10D Power Amplifier, Open Door View

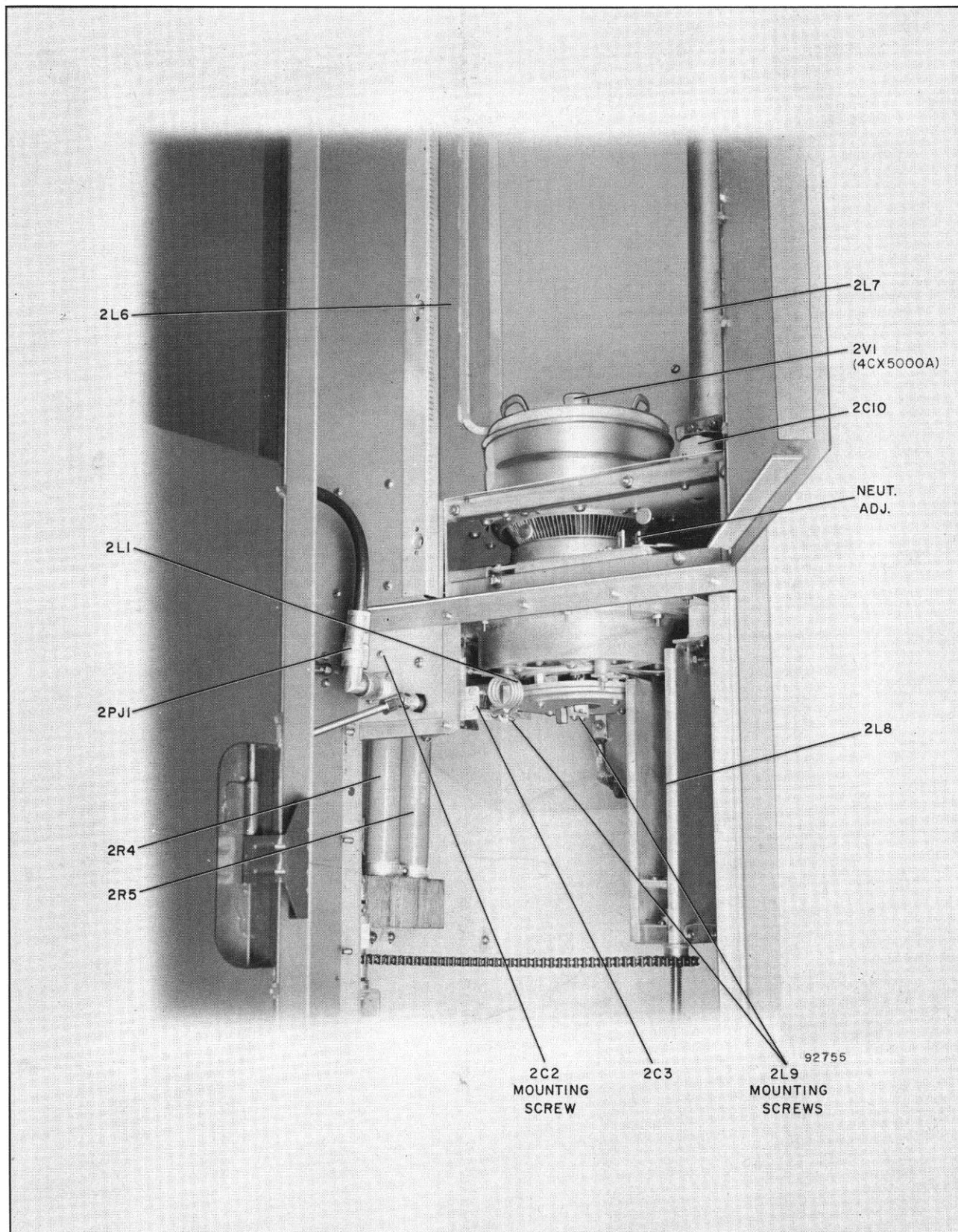

Figure T-17. BTF-10D Power Amplifier, Door Open, Panel Removed

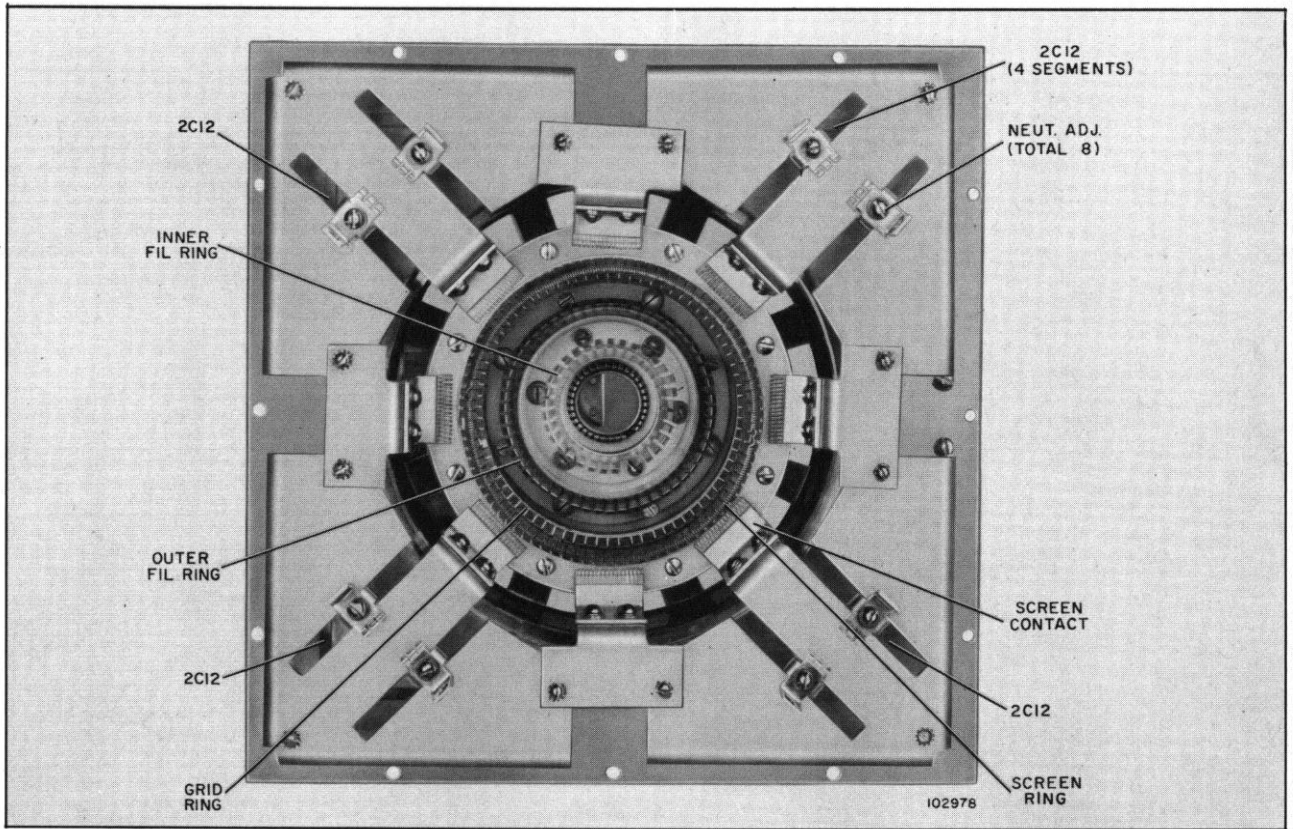

Figure T-18. PA Tube Socket, Top View

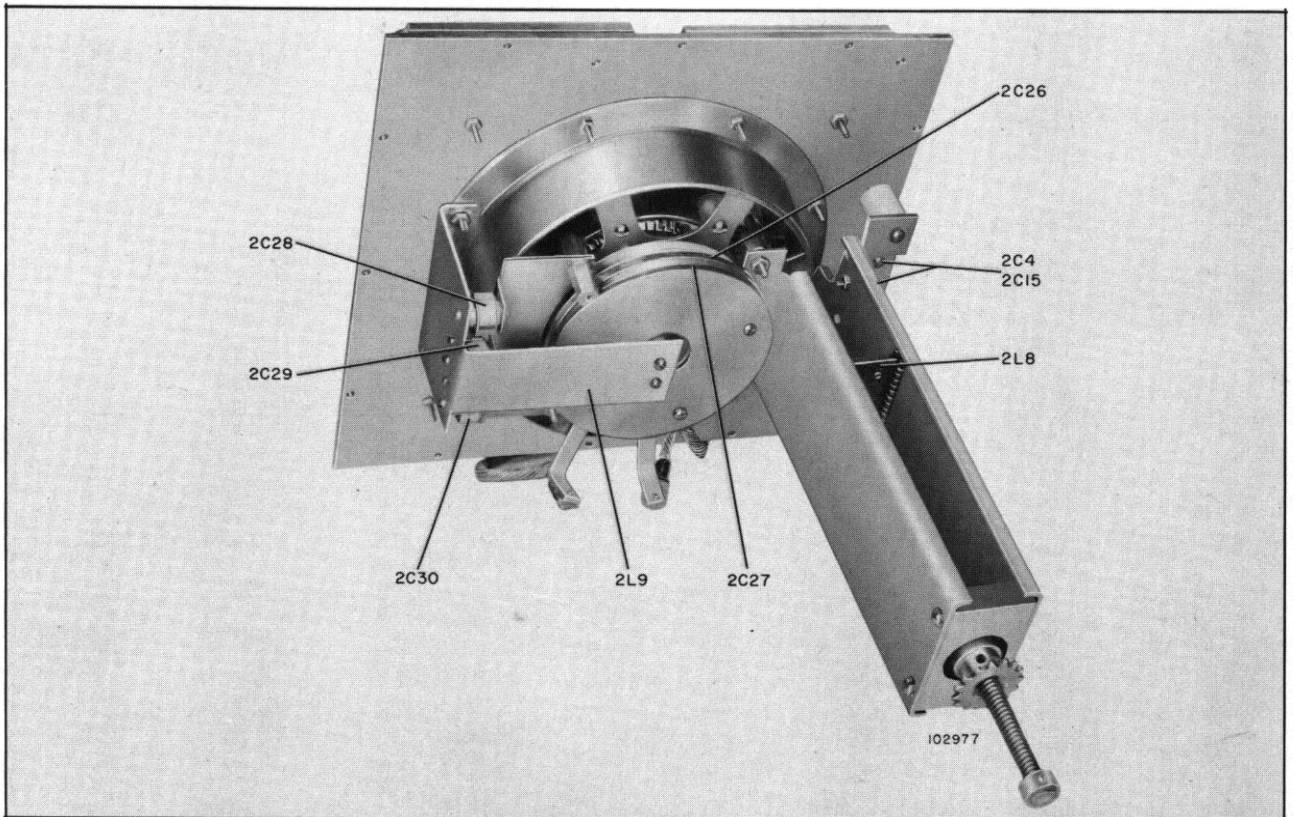

Figure T-19. PA Tube Socket, Bottom View

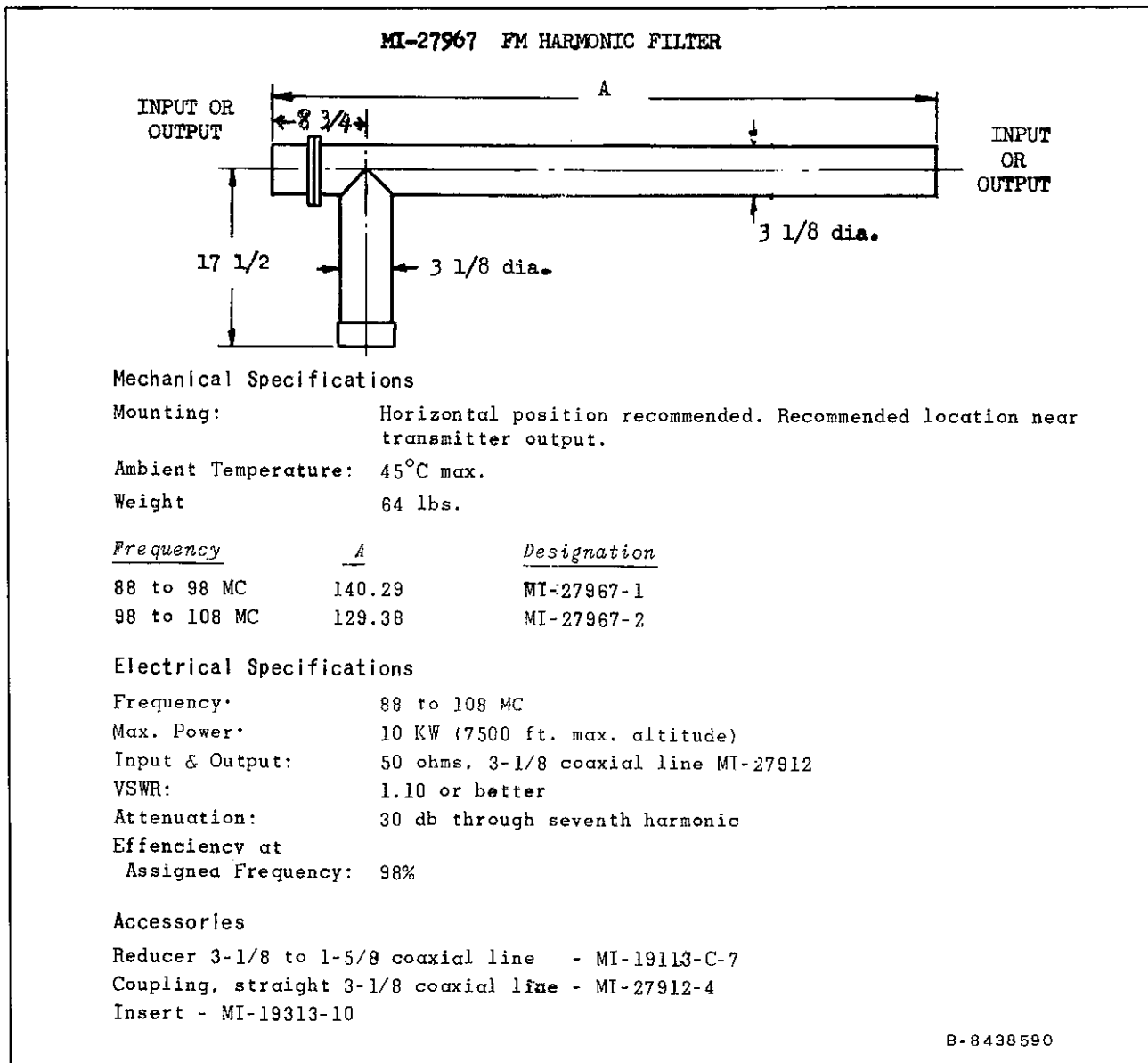

Figure T-20. Harmonic Filter, Technical Summary

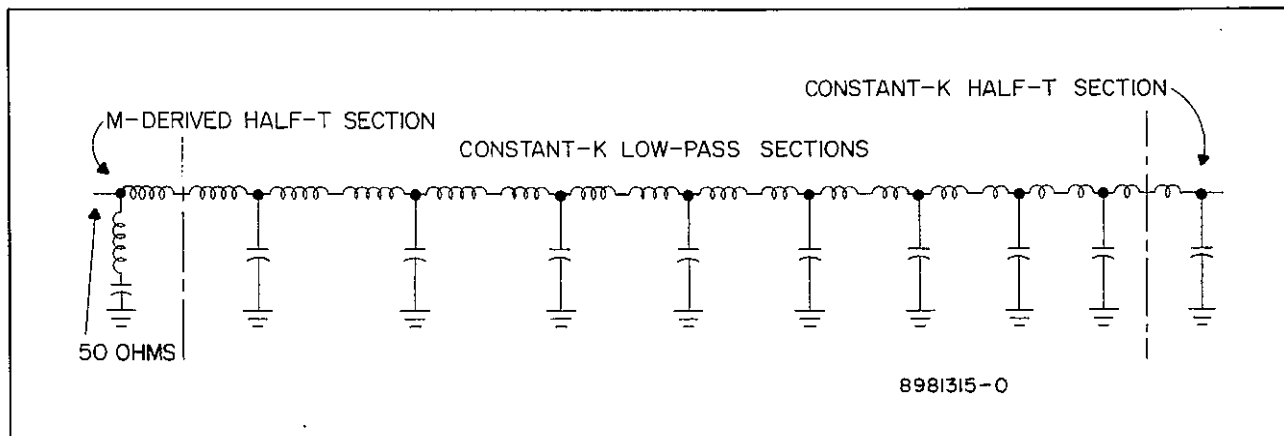
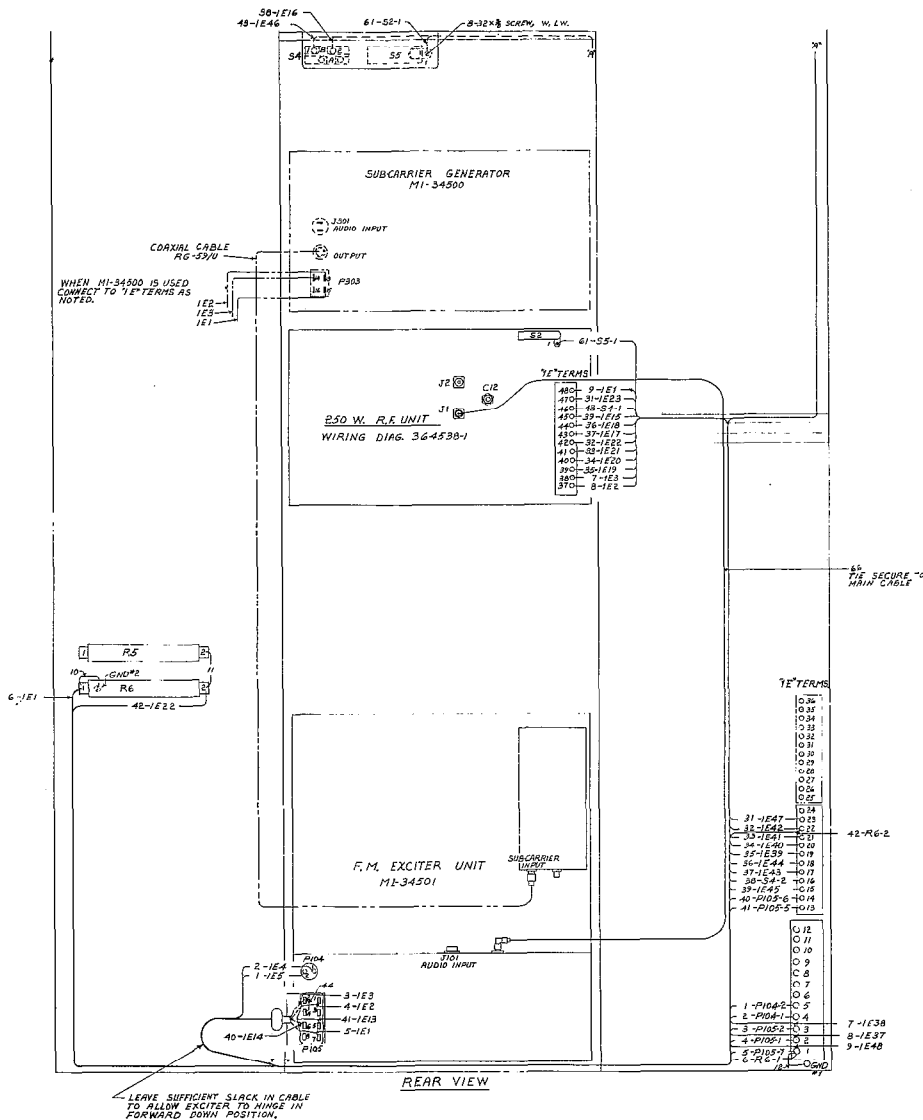

Figure T-21. Harmonic Filter, Schematic Diagram

T-38

NOTES



WIRE TABLE			
WIRE NO. INCLUSIVE	DESCRIPTION	DRY WIRE TYPE NO.	WIRE NUMBERS NOT USED
7 TO 12	WIRE BLK 200V. #16AWG	69	
31 TO 44	WIRE BLK 200V. #18AWG	70	
61	WIRE WHT 125KV DC #14AWG	71	

Figure T-22. Interconnection Diagram, BTF-10D (364539)

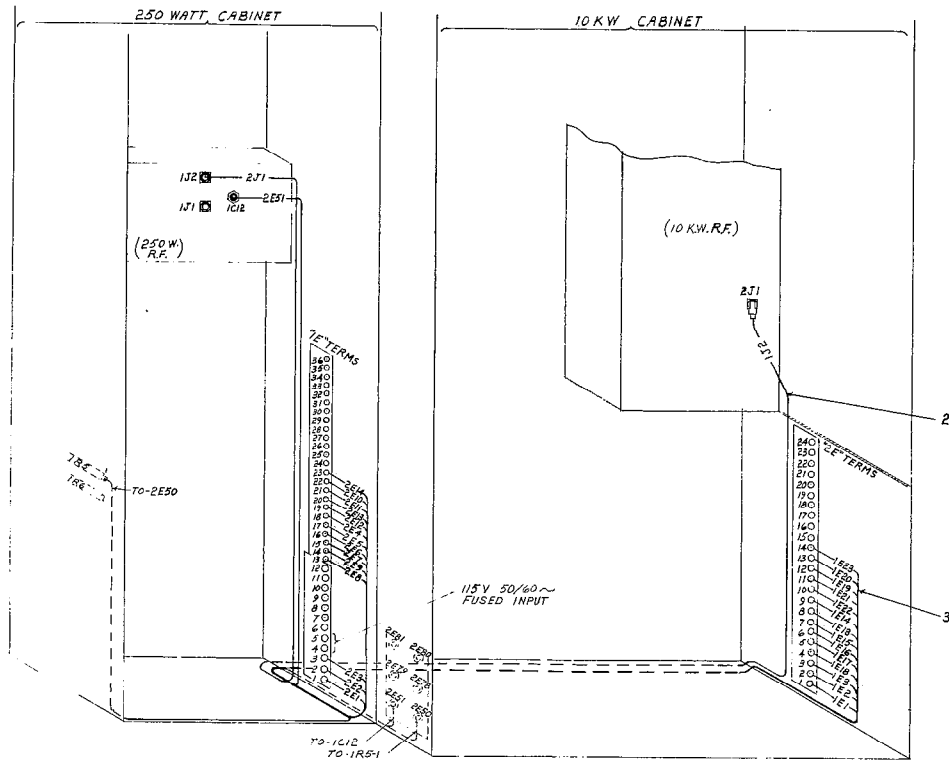

REAR VIEW

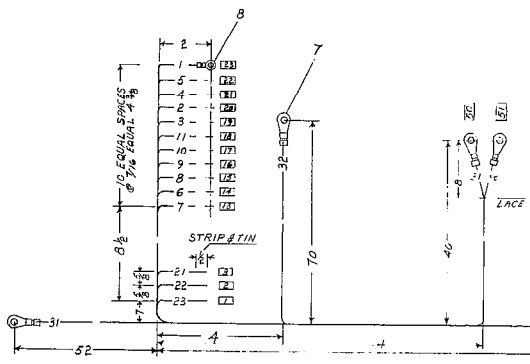

WIRE TABLE		
WIRE NUMBERS	DESCRIPTION	THIS DWG
1 TO 11	WIRE BLK 600V. 16AWG. ITEM-13	6-202
21 TO 23	WIRE BLK 600V. 14AWG. ITEM-14	
31 TO 32	WIRE WHT 15 K.V. DC. 14AWG. ITEM-15	

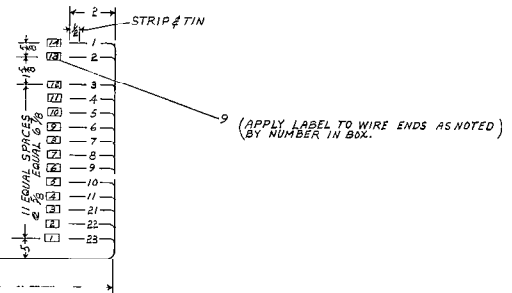

Figure T-23. Cable Assembly and Connections (18616018)

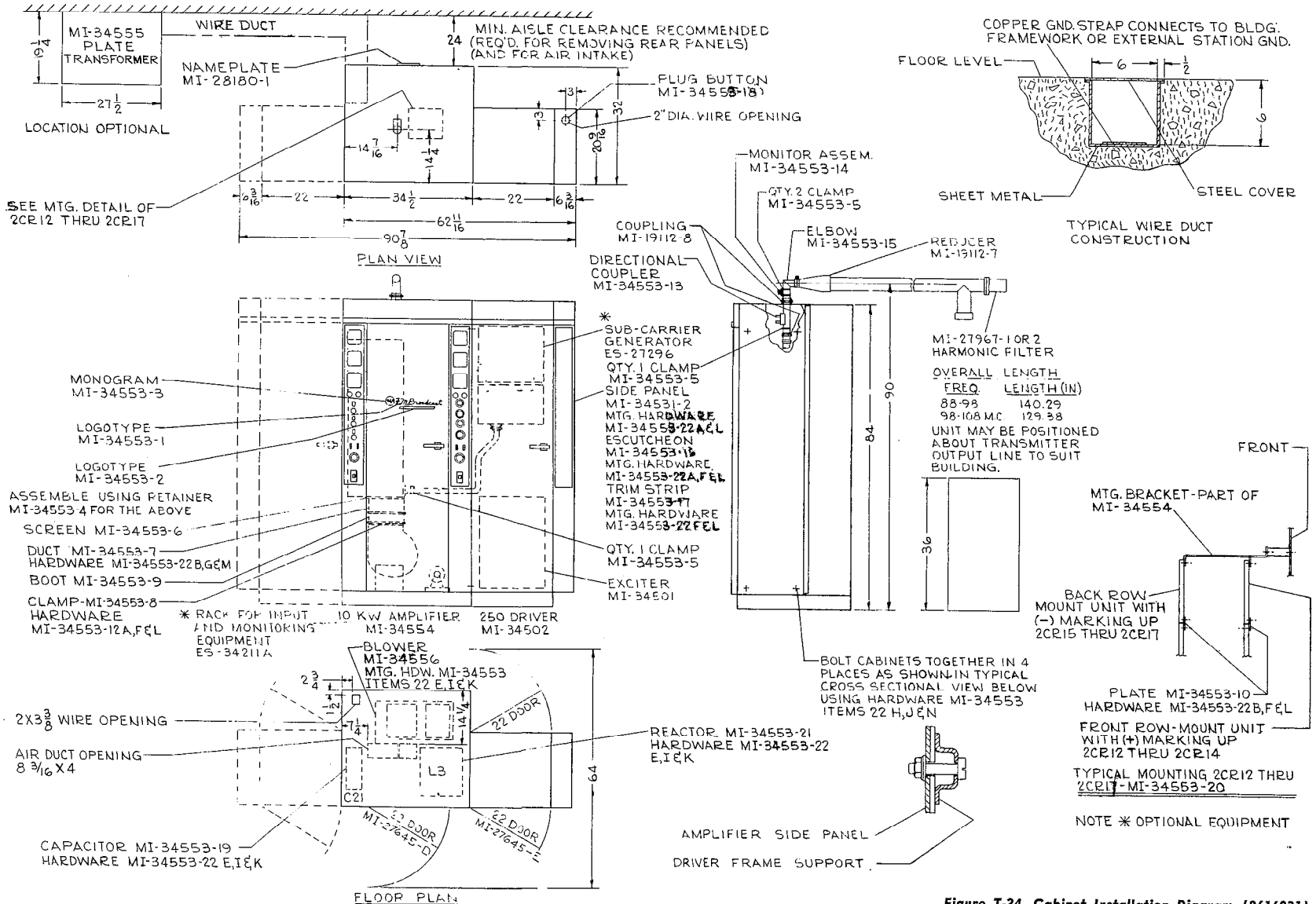
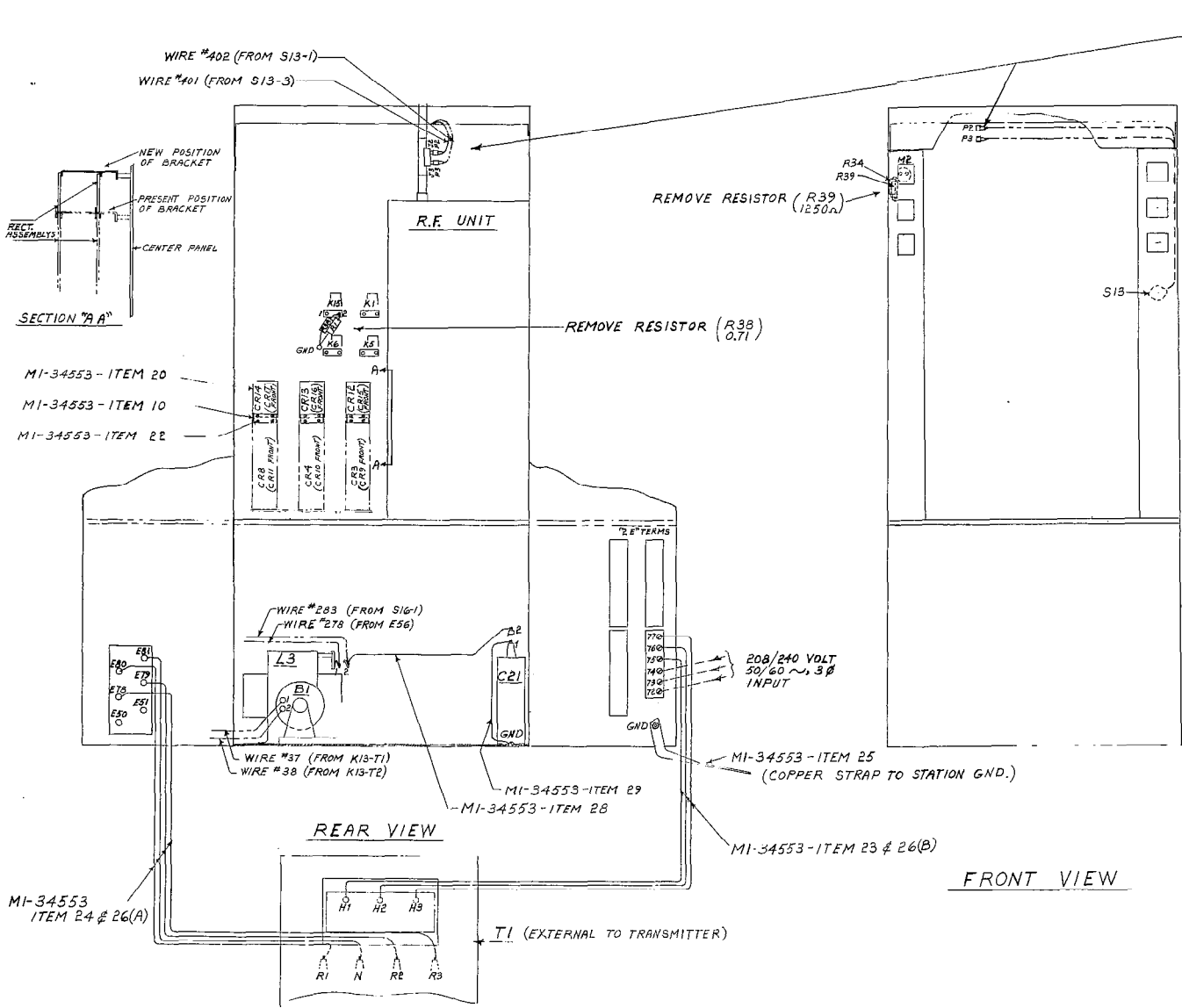

Figure T-24. Cabinet Installation Diagram (8616031)



FOLLOW INSTRUCTIONS WHICH APPLY TO TYPE COUPLER SUPPLIED.
METHOD OF ASSEMBLING RESISTOR TO LEAD FOR P2 AND P3 CONNECTORS OF DIRECTIONAL COUPLER.

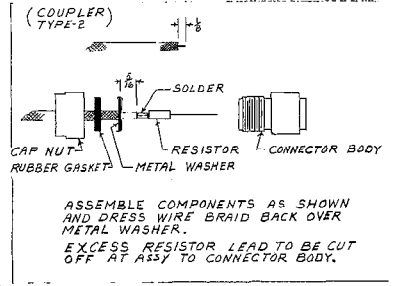
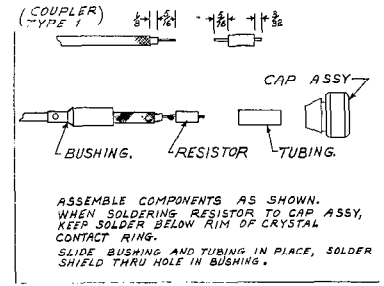

Figure T-25. Installation Wiring (8616072)

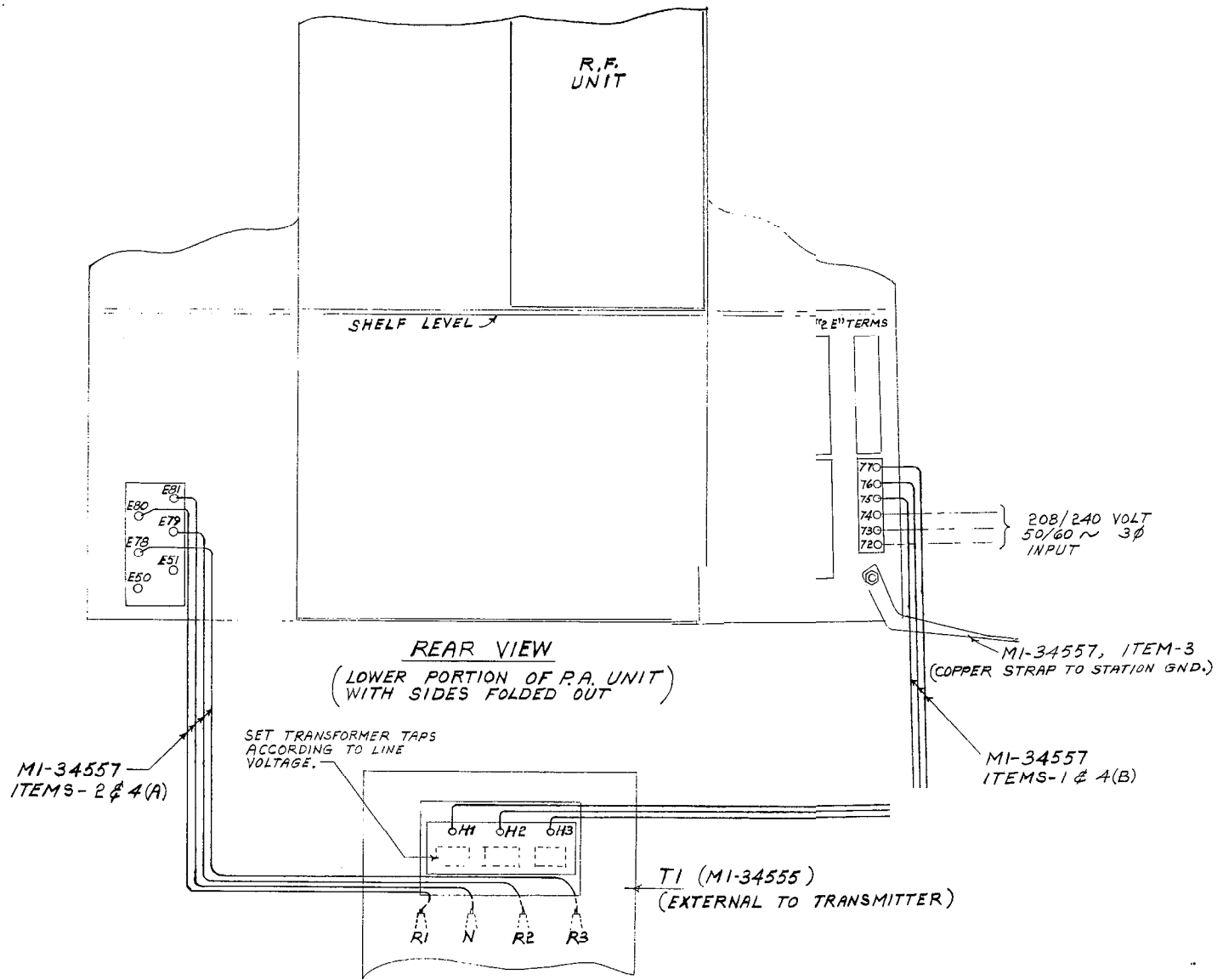

Figure T-26. Installation/Wiring.
Plate Transformer (8729601)

INSTRUCTIONS

BTE-10B

Direct FM Multiplex Exciter

ES-27278

LIST OF EQUIPMENT

BTE-10B FM Exciter (ES-27278)		
<i>Quantity</i>	<i>Description</i>	<i>Reference</i>
1	FM Exciter Unit	MI-34501
1	Crystal Unit (Spare to be ordered separately)	MI-34509*
1	Set of Operating Tubes	MI-34510
	Set of FCC Spare Tubes (Not supplied—to be ordered separately).....	
2	Instruction Books	IB-30262-1

* See table of crystals and frequencies.

RECOMMENDED SPARE PARTS

<i>Description</i>	<i>Symbol</i>	<i>Quantity</i>	<i>Stock No.</i>
Capacitor, ceramic, .01 μ f	C106, C113, C114, C115, C122, C124, C126, C130, C132, C135, C138, C140, C145, C152, C153, C157, C169, C172, C180, C184, C209, C211, C212	5	73960
Capacitor, feed thru — .001 μ f	C107, C120, C127, C129, C131, C134, C143, C144, C146, C147, C150, C166	5	99177
Capacitor, ceramic, 5 μ f	C133, C155, C156	5*	77688
Capacitor, ceramic, 2,200 μ f	C148	1	77953
Capacitor, ceramic, 10 μ f	C214, C171, C177, C183, C207, C208, C109, C110, C149, C160, C164	5*	77865
Crystal diode, 1N34A	CR101, CR102, CR104	2	59395
Lamp, neon	DS101, DS102	5*	101857
Fuse, 0.5 amp	F101, F102	2	212327
Mount, shock mount		1	57692

* 5—minimum quantity shipped.

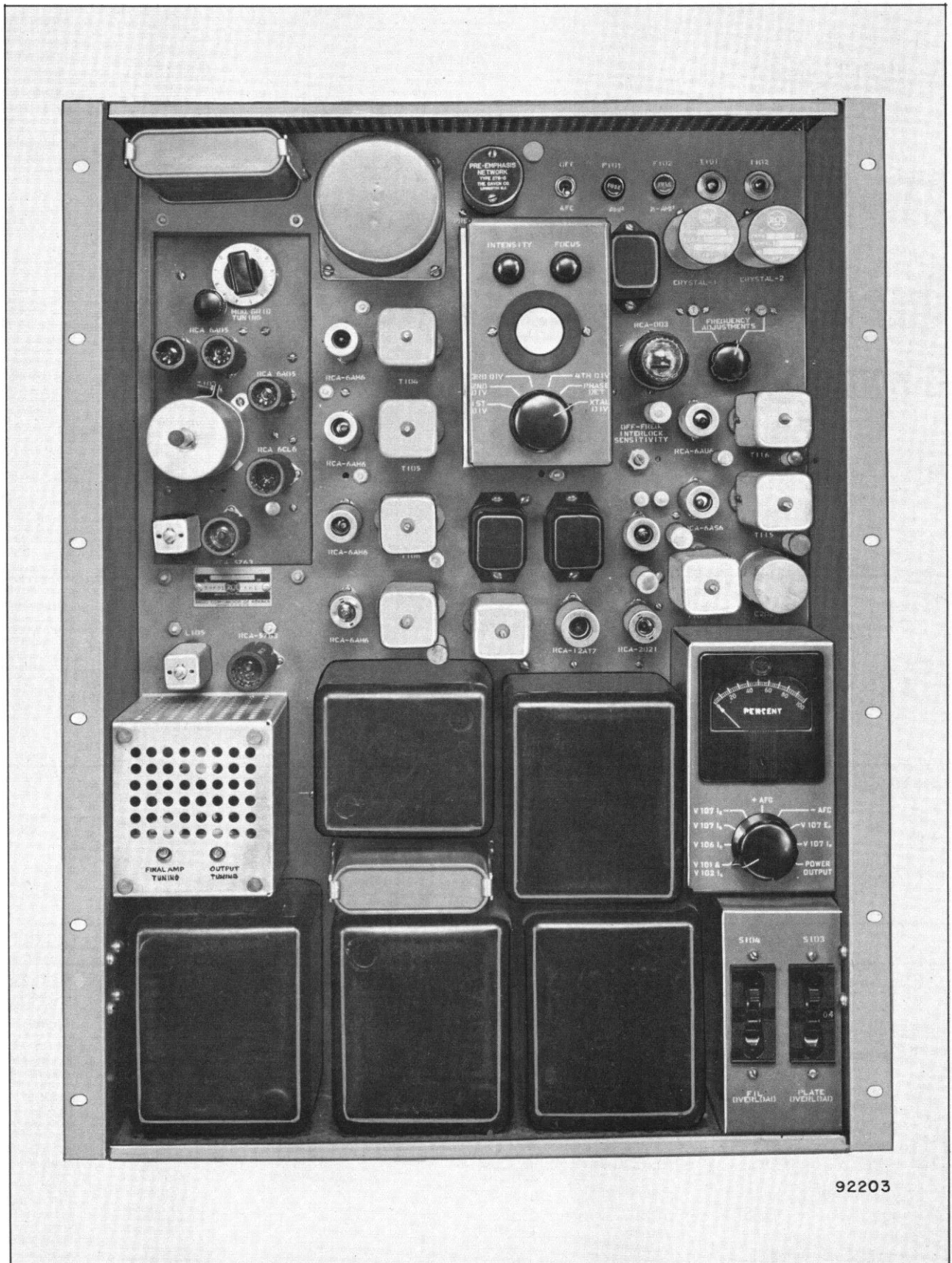

92203

Figure E-1. BTE-10B FM Multiplex Exciter

TECHNICAL SUMMARY

ELECTRICAL CHARACTERISTICS

Type of Emission	F3
Frequency Range	88-108 mc/s
Power Output	10 watts
Output Impedance	50 ohms
Frequency Deviation for 100% mod.	±75 kc/s
Modulation Capability	±100 kc/s min.
Carrier Frequency Stability	±1000 cps max.
Audio Input Impedance	600/150 ohms
Audio Input Level (100% mod.)	+10 ±2 dbm ¹
Audio Frequency Response (30-15000 cps)	±1 db max. ²
Harmonic Distortion (30-15000 cps)	0.5% max. ³
FM Noise Level (referred to 100% FM mod.)	-65 db max.
AM Noise Level (referred to carrier voltage)	-50 db max.
Sub-carrier Input Level (30% mod. of carrier)	5v max. ⁴
Sub-carrier Input Impedance	10,000 ohms
Sub-carrier Center Frequency Range	30 to 67 kc/s
Main-to-Sub-channel Crosstalk	-55 db ⁵
Sub-to-Main-channel Crosstalk	-65 db ⁵
Power Line Requirements	240/208 or 117 V, single phase 50/60 cps
Slow Voltage Variations	±5%
Power Consumption	300 watts, Approx.
Crystal Heaters	117 volts, 50-60 cps, 10 watts each
Altitude	7500 ft. max.
Ambient Temperature Range	-20°C to +45°C

MECHANICAL SPECIFICATIONS

	<i>Height</i>	<i>Width</i>	<i>Depth</i>
Overall Dimensions	24½"	19"	11"
Weight	80 lbs.		

¹Level measured at input (J101) using 400 cps tone.

²Audio frequency response referred to 75 μs pre-emphasis curve.

³Distortion includes all harmonics up to 30 kc/s and is measured following a standard 75 μs de-emphasis network.

⁴Subcarrier modulation percentage can be brought to 50% if required. (See Subcarrier Modulation in text.)

⁵Reference shall be ±7.5 kc/s deviation of the subcarrier by a 400 cps tone. Main channel modulation 70% by 30-15000 cps tones.

⁶Reference shall be ±75 kc deviation of the main carrier by a 400 cps tone. Sub-channel modulated 100% (±7.5 kc/s) by 30-6000 cps tones. Subcarrier modulated 30% on main carrier.

TUBE COMPLEMENT

<i>Symbol</i>	<i>Type</i>	<i>Function</i>	<i>Symbol</i>	<i>Type</i>	<i>Function</i>
V101	6AQ5	Reactance Modulator	V109	6AH6	Frequency Divider (1/4)
V102	6AQ5	Reactance Modulator	V110	6AH6	Frequency Divider (1/4)
V103	6AQ5	Master Oscillator	V111	6AH6	Frequency Divider (1/5)
V104	6CL6	Subcarrier Modulator	V112	6AU6	Crystal Oscillator
V105	5763	Frequency Tripler	V113	6AH6	Crystal Frequency Divider (1/5)
V106	5763	Frequency Tripler	V114	12AT7	Cathode Follower
V107	6146	Frequency Doubler and Power Amplifier	V115	6AS6	Off-Frequency Detector
V108	6AH6	Frequency Divider (1/3)	V116	2D21	Off-Frequency Control
			V117	OD3	Voltage Regulator
			V118	1EP1	Cathode Ray Tube

DESCRIPTION

The RCA BTE-10B, ES-27278, is a frequency modulated exciter which provides an r-f output of ten watts at any specified frequency in the 88 to 108 megacycle band. The compact unit incorporates a subcarrier modulator stage which can be fed from a subcarrier generator such as the RCA BTX-1A to provide for multiplexing one or two subcarriers on the main FM channel. Thus, it is designed especially to provide for various applications of FM multiplex such as background music, and, if it should become authorized, stereophonic sound.

The BTE-10B is the exciter used in the RCA BTF-5B 5KW FM Transmitter. It can be used to replace the exciter units of previous RCA FM transmitters, or that of any other FM transmitters where an exciter power output of ten watts is adequate. The unit incorporates features which make it easy to adjust, easy to maintain and very reliable in operation.

All r-f multipliers, including the output stage, employ single-tuned circuits. The exciter can be housed in a standard cabinet rack together with a subcarrier generator. Employing miniature tubes throughout, the BTE-10B is a self-contained unit with built-in power supplies and an oscilloscope to facilitate alignment.

The BTE-10B when properly adjusted, and used in conjunction with the BTX-1A Subcarrier Generator, will provide subchannel performance comparable to the main FM channel with regard to signal-to-noise ratio and distortion. The frequency response of the subcarrier will be somewhat limited when programming the subcarrier separately.

R-f multiplier and power amplifier stages of the BTE-10B use relatively broadband, single-tuned circuits, thus simplifying adjustment. A built-in meter can be switched to read the following voltages and currents: Modulator cathode current; second and third multiplier grid currents; PA cathode and plate current; AFC control voltage; and plate voltage.

The monitor oscilloscope incorporated in the exciter simplifies adjustment and maintenance of the AFC frequency dividers. A switch permits instantaneous checking and adjustment of all five dividers, and a check of the control action of the phase detector. Displays are in the form of Lissajous' figures, with the advantages that lock-in of the dividers can be observed easily. Checks can be made during operation without disturbing the AFC circuit in any way. This type display requires no synchronization or other adjustments.

Power supplies employ semiconductor rectifiers. The high voltage regulated supply which furnishes d-c plate and screen voltage utilizes a bridge type germanium rectifier. Modulator and oscillator filaments are supplied by a d-c supply employing a full wave silicon rectifier.

All components of the BTE-10B are mounted on a vertical chassis. Special hinge-type mounting pins at the bottom corners permit the top of the chassis to be swung out for access to the wiring and circuit components on the underneath side.

CIRCUITS

A block diagram of the BTE-10B Exciter is shown in Figure 2. Circuits consist of: A master oscillator which operates at 1/18th of the carrier frequency; two reactance modulators to provide modulation for the main channel; a third reactance modulator for the subcarrier; three frequency multipliers including the output stage to bring the output frequency up to the 88 to 108 mc range; automatic frequency control circuitry; and power supplies to furnish a-c and d-c voltages for these stages.

The master oscillator is a 6AQ5 Hartley type oscillator which operates at a frequency between approximately five and six mc., depending upon the desired output frequency. The plates of the two 6AQ5 reactance modulators are connected to the oscillator plate, and the grids, which are in push-pull, are inductively coupled to the plate tank. R-f voltages on the two modulator grids are 180 degrees out of phase with respect to each other, and each is 90 degrees out of phase with the oscillator plate. Thus, one tube appears as a capacitive reactance and the other appears as an inductive reactance across the oscillator tank. The magnitude of the reactive component presented to the tank coil varies with the audio voltage applied to the modulator grids, and the frequency of the oscillator is varied accordingly. The mean frequency is controlled by the bias voltage applied to one grid. This bias voltage is supplied by the automatic frequency control circuit to be described in a later paragraph.

The third reactance modulator, an RCA Type 6CL6, provides for modulation of the subcarrier on the main r-f carrier. This reactance tube is coupled to only a part of the oscillator coil since the required deviation of the r-f carrier by the subcarrier is small.

Use of the pushpull modulator and the inductive coupling circuit results in a highly linear operation

BTE-10B EXCITER CRYSTALS

MI No.*	Carrier Frequency (MC)	Crystal Frequency (KC)	MI No.*	Carrier Frequency (MC)	Crystal Frequency (KC)
34509-1	88.1	101.9676	34509-51	98.1	113.5417
-2	88.3	102.1991	-52	98.3	113.7731
-3	88.5	102.4306	-53	98.5	114.0046
-4	88.7	102.6620	-54	98.7	114.2361
-5	88.9	102.8935	-55	98.9	114.4676
-6	89.1	103.1250	-56	99.1	114.6991
-7	89.3	103.3565	-57	99.3	114.9306
-8	89.5	103.5880	-58	99.5	115.1620
-9	89.7	103.8194	-59	99.7	115.3935
-10	89.9	104.0509	-60	99.9	115.6250
-11	90.1	104.2824	-61	100.1	115.8565
-12	90.3	104.5139	-62	100.3	116.0880
-13	90.5	104.7454	-63	100.5	116.3194
-14	90.7	104.9769	-64	100.7	116.5509
-15	90.9	105.2083	-65	100.9	116.7824
-16	91.1	105.4398	-66	101.1	117.0139
-17	91.3	105.6713	-67	101.3	117.2454
-18	91.5	105.9028	-68	101.5	117.4769
-19	91.7	106.1343	-69	101.7	117.7083
-20	91.9	106.3657	-70	101.9	117.9383
-21	92.1	106.5972	-71	102.1	118.1713
-22	92.3	106.8287	-72	102.3	118.4028
-23	92.5	107.0602	-73	102.5	118.6343
-24	92.7	107.2917	-74	102.7	118.8657
-25	92.9	107.5231	-75	102.9	119.0972
-26	93.1	107.7546	-76	103.1	119.3287
-27	93.3	107.9861	-77	103.3	119.5602
-28	93.5	108.2176	-78	103.5	119.7917
-29	93.7	108.4491	-79	103.7	120.0231
-30	93.9	108.6806	-80	103.9	120.2546
-31	94.1	108.9120	-81	104.1	120.4861
-32	94.3	109.1435	-82	104.3	120.7176
-33	94.5	109.3750	-83	104.5	120.9491
-34	94.7	109.6065	-84	104.7	121.1806
-35	94.9	109.8380	-85	104.9	121.4120
-36	95.1	110.0694	-86	105.1	121.6435
-37	95.3	110.3009	-87	105.3	121.8750
-38	95.5	110.5324	-88	105.5	122.1065
-39	95.7	110.7639	-89	105.7	122.3380
-40	95.9	110.9954	-90	105.9	122.5694
-41	96.1	111.2269	-91	106.1	122.8009
-42	96.3	111.4583	-92	106.3	123.0324
-43	96.5	111.6898	-93	106.5	123.2639
-44	96.7	111.9213	-94	106.7	123.4954
-45	96.9	112.1528	-95	106.9	123.7268
-46	97.1	112.3843	-96	107.1	123.9583
-47	97.3	112.6157	-97	107.3	124.1898
-48	97.5	112.8472	-98	107.5	124.4213
-49	97.7	113.0787	-99	107.7	124.6528
-50	97.9	113.3102	-100	107.9	124.8843

* Suffixes 1 to 100 designate channel number. Add 200 to suffix to get FCC channel number, e.g., MI-34509-75 designates FCC channel 275, frequency 102.9 mc.

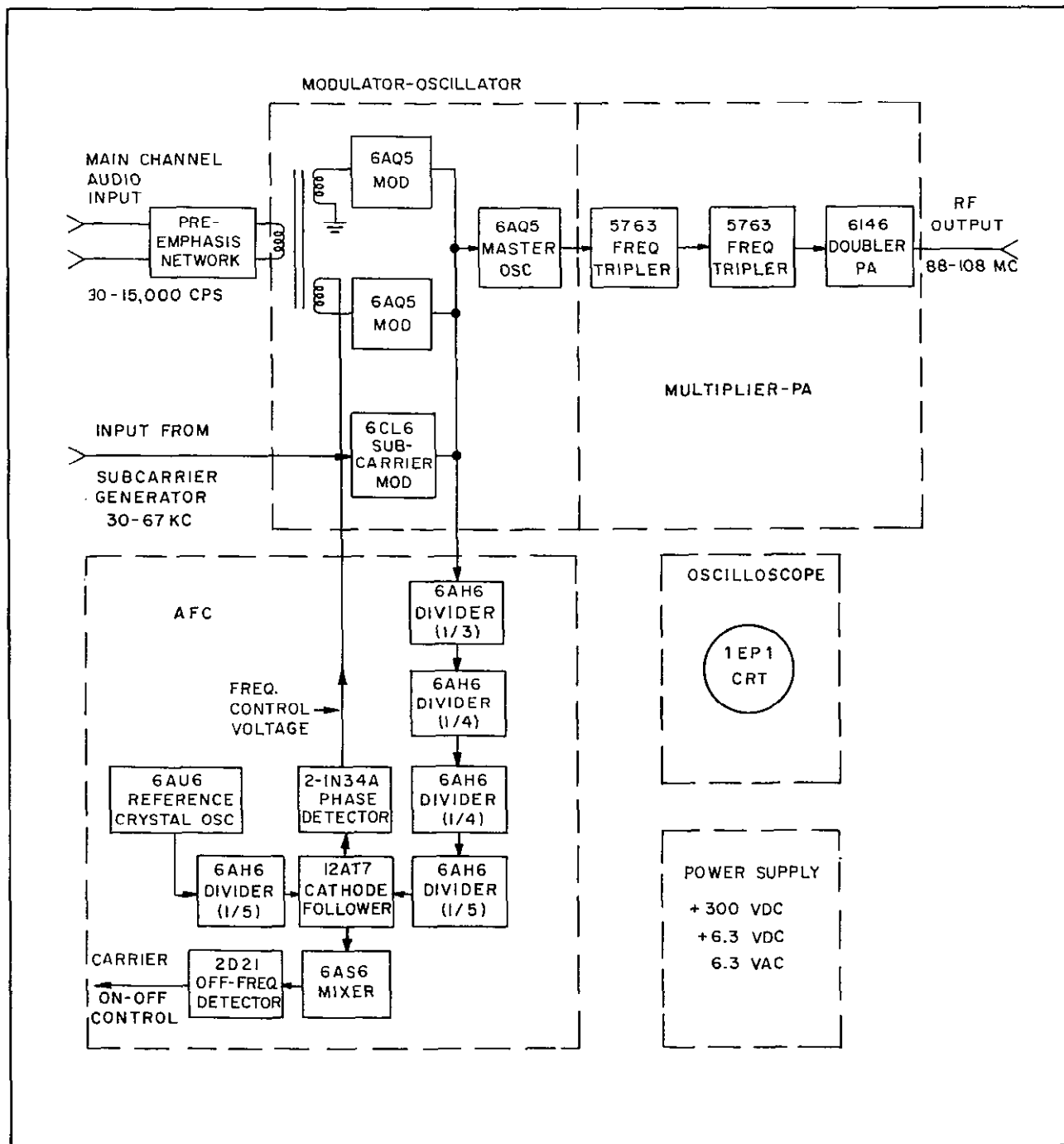

Figure E-2. Block Diagram, BTE-10B FM Exciter

with very low harmonic distortion. Each tube is almost a pure reactance, and loading of the oscillator is greatly reduced, providing better AFC action. Moreover, the pushpull modulator automatically balances out temperature and supply-voltage changes. Modulating circuits are very effectively decoupled, thus minimizing the possibility of cross-talk between the main channel and subchannel, and vice versa.

Automatic Frequency Control

The automatic frequency control circuitry of the BTE-10B Exciter is characterized by a long record of dependable operation. A phase detector is used to develop a control voltage which establishes and maintains a phase lock between a reference crystal oscillator and the derived signal. Thus the system is actually an automatic phase control system which

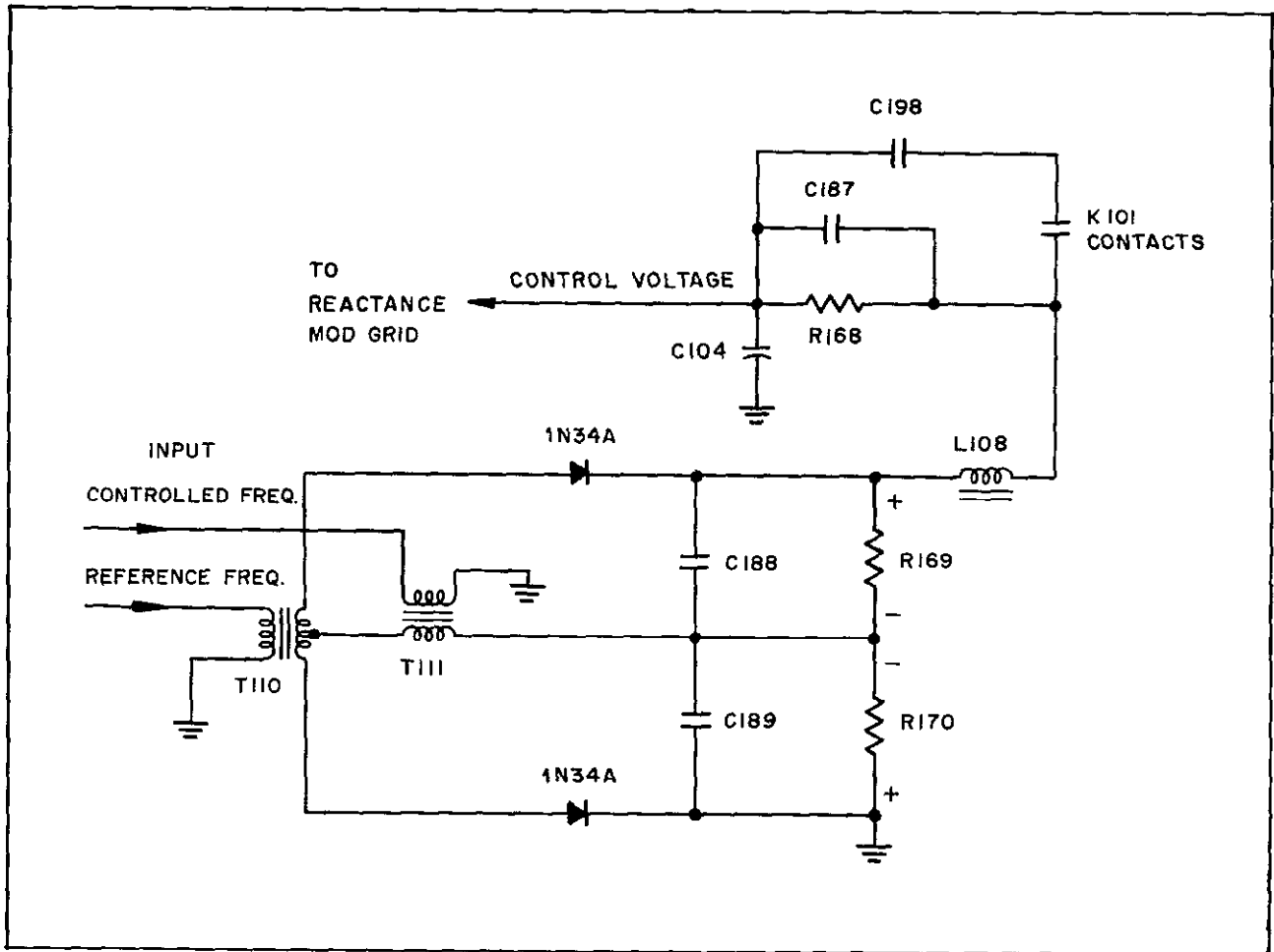

Figure E-3. Simplified Schematic, BTE-10B Phase Detector

achieves a stability precisely matching that of the crystal reference source. To confine the phase deviations of the master oscillator signal to within range of the phase detector, and in order not to exceed the possible speed of the low pass network in the AFC circuit, the master oscillator frequency and swing must be reduced. This is accomplished in locked-oscillator type dividers with an overall division of 240. Thus the maximum phase deviation at the lowest audio frequency (30 cps) is ± 58 degrees (at ± 100 kc deviation of the final frequency), and well within the limits of linearity of the phase detector.

The limited pull-in range normally associated with precise frequency control is overcome by the use of an off-frequency circuit which extends the pull-in range to ± 400 kc (at the final frequency), and simultaneously provides a safeguard against uncontrolled and possible off-frequency operation.

Circuits of the AFC system are diagrammed in Figure 2. A small r-f voltage is fed from the master

oscillator circuit to the divider chain where it is divided by 240 to a range of 20 to 25 kc. It should be noted that, at the same time, deviation due to modulation is reduced from a maximum of ± 5 kc to ± 20 cps. From the dividers, this voltage is fed through a cathode follower to a phase detector employing two 1N34A diodes. A reference voltage of the same frequency, fed into the phase detector, is obtained by dividing by five the frequency of the reference crystal oscillator.

Operation of the phase detector is illustrated in the simplified diagram of Figure 3, and by the vector diagram of Figure 4. Assuming that the master oscillator is exactly on frequency, with no correction bias applied to its grid, the two input signals applied to T110 and T111 therefore are of the same frequency but 90 degrees out of phase. The reference frequency signal is applied to T110, and the voltage developed across the top half of the secondary is represented by vector BA in Figure 4 (a), while the voltage across the lower half is represented by vector BC.

These two voltages are equal in magnitude and 180 degrees out of phase. The controlled frequency signal is applied to T111, and the voltage developed across its secondary is represented by vector BD, which is 90 degrees out of phase with each of the other two. The voltage impressed across each 1N34A crystal rectifier and its associated load (R169 and R170) is then the vector sum of the series voltages E_1 and E_2 respectively. Since the magnitudes of E_1 and E_2 are equal, the d-c voltages across R169 and R170 will be equal and of the polarity shown. Hence, the voltage as measured from the top of R169 to ground will be zero.

If, however, the frequency of the master oscillator should *decrease*, the relative phase of the two input signals and their vector relationships will change as shown in Figure 4 (b). Since the magnitude of E_1 is now greater than that of E_2 , the d-c voltage across R169 will be greater than that across R170 and a net *positive* correction voltage appearing at the top of R169 will be applied to the reactance tube grid, correcting the frequency. Accordingly, if the oscillator frequency should *increase*, the vector relationships change as shown in Figure 4 (c), and a net *negative* correcting voltage is applied to the reactance tube grid. Thus any departure from the 90-degree phase relationship between the two signals is instantaneously corrected by a proper error voltage. High frequency components of the input signals are filtered out of the control voltage by the capacitors C188 and C189 and the choke L108.

The network consisting of capacitors C104, C187, C198 and resistor R168 extends the control range of the phase detector beyond the ± 90 degree phase difference limit that would otherwise be imposed, by feeding a small amount of the beat frequency back to the reactance tube grid. This beat frequency then causes the master oscillator frequency to swing in both directions at the difference frequency rate. The amount of frequency deviation is proportional to the amplitude of the signal at the reactance tube grid; and in order to produce sufficient swing without objectionable audio frequency feedback, capacitor C187 is made small and is paralleled by a larger capacitor C198 which is switched in only when the master oscillator is "hunting." The switching is done automatically by the off-frequency detector described in a later paragraph.

If the signal at the reactance tube grid is sinusoidal, there will be no d-c component and the mean frequency of the master oscillator will remain unchanged. However, the beat frequency at the phase detector output, when it is not locked in, is non-symmetrical and has a d-c component of the proper polarity to change the mean frequency of the master oscillator toward its correct frequency.

To illustrate how the non-symmetrical waveform is developed, take an example in which the frequency of the master oscillator is such as to produce a signal at T111 which is 0.1 kc low. A difference frequency of 0.1 kc will be fed to the reactance tube grid, and

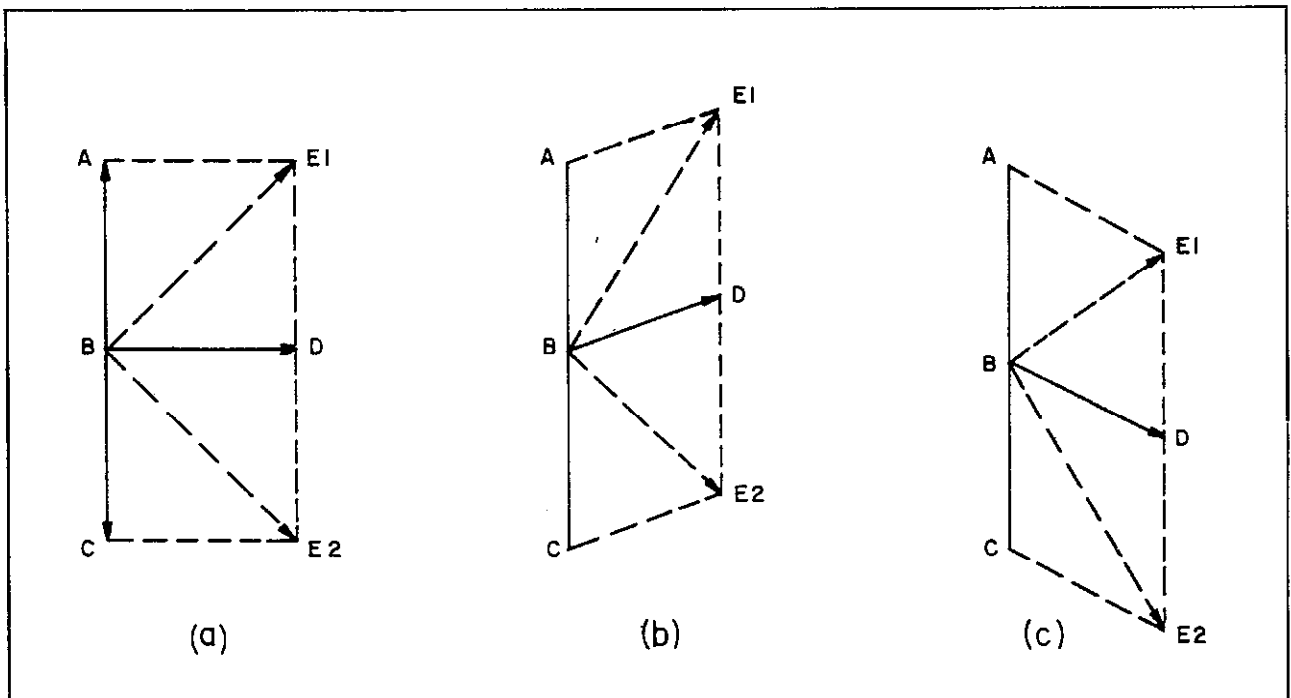

Figure E-4. Phase Detector Signal Voltages

the master oscillator will then swing above and below the tuned frequency one hundred times per second. The dashed line curve of Figure 5 (a) is the waveform of the beat frequency which would appear at the junction of L108 and R168 if C104 were shorted. If this waveform was fed back to the reactance tube through a blocking capacitor, the solid line waveform would appear at the same point. Note that the solid line waveform is slightly distorted so that its axis no longer represents zero d-c voltage.

The positive peak of the solid line waveform in Figure 5 (a) is produced as the master oscillator frequency swings further away from its frequency, and the negative peak is produced as it approaches its correct frequency. As the controlled frequency approaches the reference frequency, the beat becomes increasingly slower, and the distorted waveform is produced. The d-c component produced across C104 is of such polarity as to change the master oscillator frequency toward its correct frequency.

Figures 5 (b) through (d) are the same as (a) except for the frequency of the beat. Note that as the beat frequency becomes lower, the distortion becomes greater, producing a corresponding increasing d-c component. The waveforms shown can be produced by blocking the d-c component from the reactance tube and by tuning the master oscillator for the desired beat frequency. However, when the d-c component is fed to the reactance tube grid, the beat frequency automatically decreases until it is zero. The system is then "locked in" and the d-c voltage maintains that condition.

Off-Frequency Detector

Protection against loss of control by the automatic frequency control system, and possible off-frequency operation, is provided by the off-frequency detector circuit shown in Figure 6. V115 is a 6AS6 mixer stage which is fed from the last divider in each chain as shown in Figure 2. The plate load of the stage is by-passed by capacitor C193, which is a low impedance to the beating frequencies and to the sum of the beating frequencies, eliminating these signals in the output.

When the master oscillator is on frequency there is no difference frequency produced in V115, and therefore the output of the stage is zero. If for any reason a difference occurs in the two beating frequencies, however, the difference frequency component appears across the plate load and hence across the thyatron grid resistor R172. If the positive half of this alternating voltage exceeds the fixed cathode bias applied to the thyatron V116, the tube conducts, energizing relay K101. One (normally closed) set of contacts on relay K101 operates the transmitter interlock circuit, preventing plate power from being applied to the PA; another set of contacts (normally open) switches in the feedback capacitor C198, shown in Figure 3, for purposes previously described.

Sensitivity of the circuit is adjusted by the thyatron bias resistor R174. This adjustment is set so that the low modulating frequencies will not trigger the thyatron but so that the beat frequencies will cause it to fire.

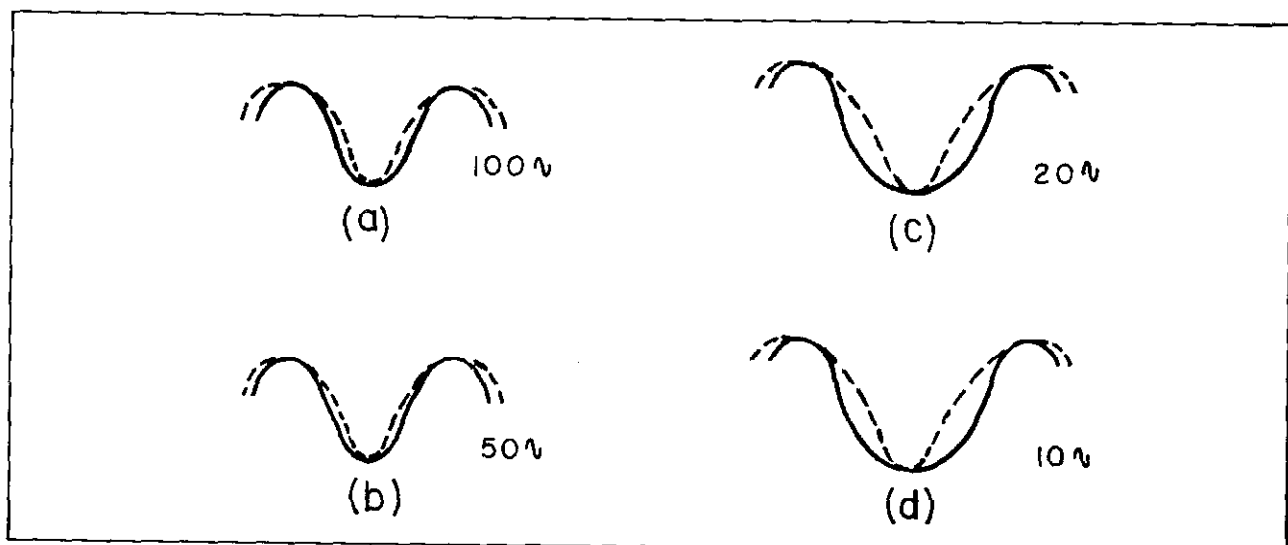

Figure E-5. Phase Detector Output Waveforms

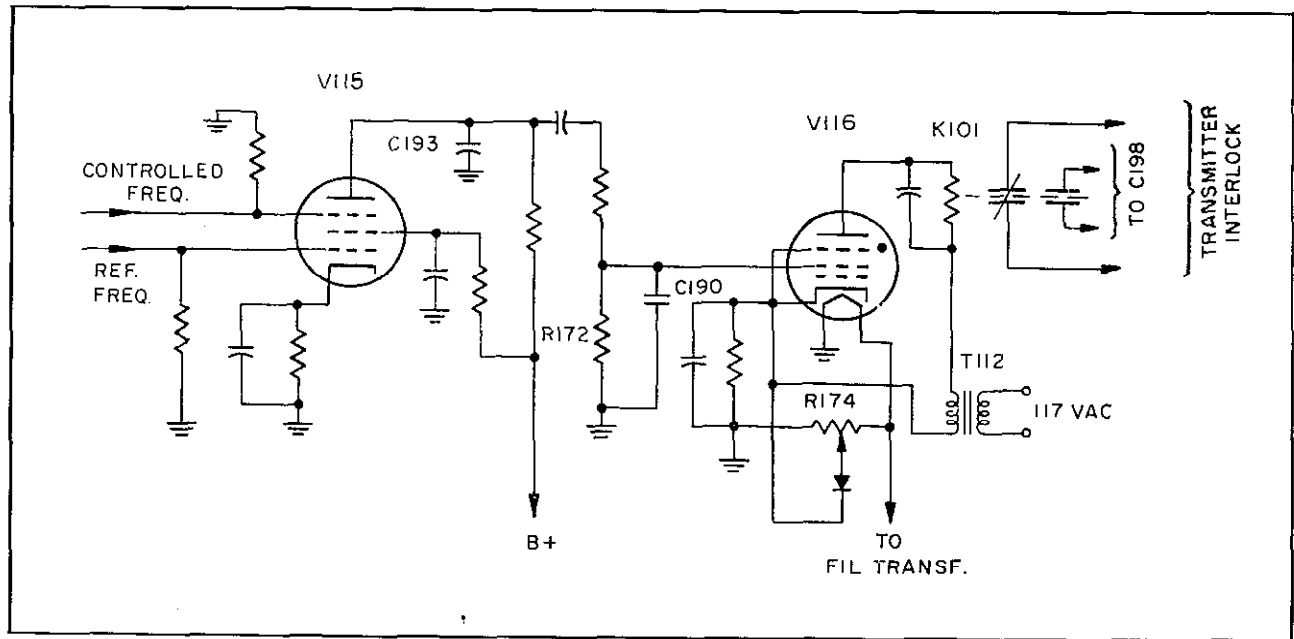

Figure E-6. Simplified Schematic, Off-Frequency Detector

INSTALLATION

Carefully unpack and inspect the equipment to make certain that no damage has been incurred during shipment. Any damages or shortages should be immediately reported to RCA and to the transportation company in order that lost or damaged material may be recovered.

The equipment is shipped complete in one container, excepting tubes and crystals which are packed separately. All internal wiring is done at the factory, only external cables and wiring need be prepared and connected to the equipment at installation. Reference should be made to the interconnection diagram of this book which designates the cables and wiring to be used and the proper connections.

A-C Power Line Connections

The primaries of the plate transformer (T113) and the filament transformer (T114) are each tapped for operation from either 120-volt or 240-volt single-phase a-c lines. The equipment is shipped with the

taps set for 240-volt use. *The crystal heaters must be connected only to a 120-volt a-c source.* Particular care must be taken to insure that proper connections are made before power is applied to the equipment. Reference should be made to the overall schematic diagram and to the table *Transformer Primary Taps* for making connections. *If 240 volts is used, be sure not to disconnect T112 (black leads) from the 120-volt terminals 4 and 2 of T113.*

The a-c overload switch (S104) can be used as a "Power Off-On" switch, if desired, and the d-c overload switch (S103) for "Standby" plate switching. The connections of these circuit-breakers are shown in the overall schematic diagram.

Tubes should be inserted in their proper sockets by reference to the type number designations printed near the appropriate sockets. Crystal Units MI-34509 should be inserted into the sockets marked "CRYSTAL 1" and "CRYSTAL 2."

TRANSFORMER PRIMARY TAPS

Power Line Voltage:	106	117	128	197	208	219	229	240	251
Taps to be Used:	3-4	2-4	1-4	3-5	2-5	1-5	3-6	2-6	1-6
	Tap C of "AC OVERLOAD" Circuit Breaker			Tap B of "AC OVERLOAD" Circuit Breaker					

After tubes and crystals are in place, and all connections are properly made, a-c power can be applied to the equipment. Allow sufficient time for tubes and the crystals heaters to reach operating temperature before following the tune-up procedure below. Indicators DS101 and DS102 will light when the crystal oven heaters are on.

Tune-Up Procedure

The oscilloscope patterns illustrated in these pages were obtained on the built-in CRO during tune-up of an exciter unit. These patterns should be considered as typical of those to be expected; slight deviations from these displays may occur in individual units.

1. With the equipment operating and indicators "DS101" and "DS102" extinguished, indicating that the crystal heaters have reached operating temperature, switch "AFC-OFF" switch to "OFF" position. With the CRO Switch (S106) in any position, advance the "INTENSITY" control (R185) clockwise until a trace appears on the face of the tube (V118). Then adjust "FOCUS" (R183) for proper sharpness. Switch meter-switch (S102) to "V107 E_p" position and check plate voltage. (Reading should be between 54 and 66.) Turn "OFF-FREQUENCY INTERLOCK SENSITIVITY" (R176) to extreme clockwise position.

2. Turn CRO switch to "XTAL DIV" position. Adjust top screw of L112 for maximum horizontal size of CRT pattern. (1/8" to 3/16" will be satisfactory).

3. Adjust top screw of T115 to obtain stationary Lissajous' figure indicating a division ratio of 1/5. (Pattern should have five left-hand loops and five right-hand loops.) Adjust top screw of T109 for maximum vertical size of pattern. See Figure 7 a.

4. Set the master oscillator to the approximate operating frequency which is 1/18 of the final carrier frequency. E.g., 88.1 mc corresponds to 4894 kc master oscillator frequency. Use grid-dipper, calibrated receiver or frequency meter. Use bottom screw of T103 to make this adjustment setting the top (fine) adjustment to a mid-position.

5. Turn CRO-Switch to "1ST DIV" position and adjust T14 for a stationary Lissajous' figure and a division ratio of 1/3. See Figure 7 b.

NOTE: Too high an inductance, when the adjusting screw is all the way in, means a low frequency and a possible division ratio of 1/4 or 1/5 or more. Too low an inductance may result in a 1/2 division ratio.

6. Turn CRO-Switch to "2ND DIV" position and adjust T105 for a stationary Lissajous' figure and a division ratio of 1/4 (Figure 7 c).

7. Turn CRO-Switch to "3RD DIV" position and adjust T106 for a stationary Lissajous' figure and a division ratio of 1/4 (Figure 7 d).

8. Turn CRO-Switch to "4TH DIV" position and adjust T107 for stationary Lissajous' figure and a division ratio of 1/5. Adjust T108 for maximum horizontal size of pattern (Figure 7 e).

9. Turn CRO-Switch to "PHASE DET" position. A square of medium brightness should be seen representing an unstationary Lissajous' circle. The rate of change of the circle depends on the frequency-difference between the reference signal and the divided master oscillator signal. Rotate the bottom screw of T103 slowly in both directions trying to find the point where both signals agree in frequency resulting in a slowly changing Lissajous' circle. During the variation of T103 make sure as you change frequency that all dividers (T104-T107) are still locked in. If a nearly stationary circle cannot be obtained, try again starting on a somewhat higher or lower frequency.

10. If a slowly changing circle was obtained, switch meter switch (S102) to "V101 & V102 I_k" position and adjust "MODULATOR GRID TUNING" (C105) for peak indication. Slight resetting of T103 bottom adjustment may be required to obtain slowly moving Lissajous' circle. Then switch "AFC" switch (S101) to "ON" position. The circle should "jump" into a completely stationary circle now. (See Figure 7 f.) In addition to the CRO the phase detector output voltage can be observed also on the built-in meter, with the meter switch in "+ or -AFC" position. With AFC on, both positions should give nearly zero readings. With AFC off, frequency differences at the phase detector up to a few cps can be observed with the meter.

11. A more sensitive adjustment of "MODULATOR GRID TUNING" (C105) can be made by applying 50 cps at approximately +10 db to the audio input connector (J101), and adjusting C105 for maximum indication on the modulation percentage meter of a modulation monitor.

12. Tune L104 to maximum indication of the meter (M101) with meter switch (S102) in "I, V106" position.

13. Steps 11 and 12 may slightly change the master oscillator frequency. So, AFC should be switched off and with CRO switch in "PHASE DET" position the circle should be made near-stationary by tuning T103 with the fine control knob on top of the can. Then throw "AFC-OFF" switch back to "AFC" position.

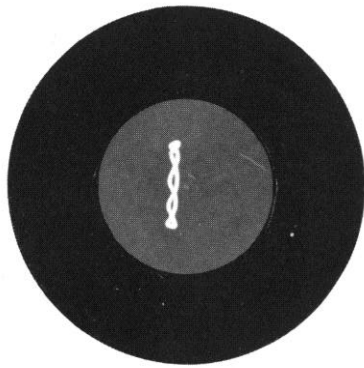

(a) Switch Position:
"XTAL DIV." (1/5)



(b) Switch Position:
"1st DIV." (1/3)



(c) Switch Position:
"2nd DIV." (1/4)

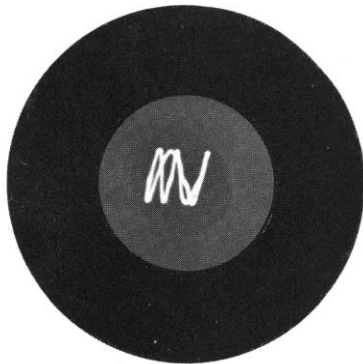

(d) Switch Position:
"3rd DIV." (1/4)

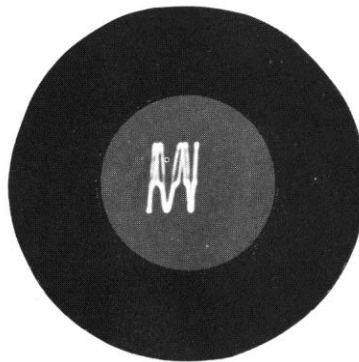

(e) Switch Position:
"4th DIV." (1/5)

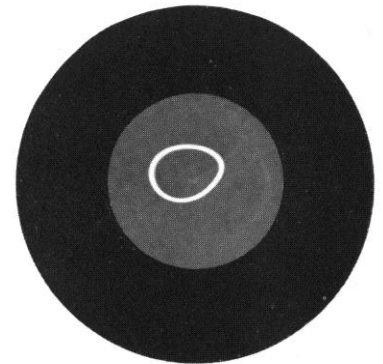

(f) Switch Position:
"PHASE DET."

Figure E-7. BTE-10B Oscilloscope Patterns

NOTE: T104 to T107 stay locked in over a certain frequency range. It is desirable to have T104-T107 adjusted so that they normally operate in the middle of their lock-in range. In order to assure this, switch CRO-Switch to "1ST DIV" position. Now turn tuning screw on top of T104 to the left until the divider unlocks (Lissajous' figure gets "fuzzy"). Start turning screw to the right and observe the number of revolutions until it unlocks at the other end of the range. Turn screw back half the number of revolutions counted. Repeat this for T105, T106, T107, and T115.

14. Tune L105 to maximum indication of meter; meter switch in "I_c V107" position.

NOTE: Remove C214 for center frequencies above 100 mc.

15. Tune C137 "PLATE TUNING" to dip on meter, meter switch in "I_k V107" or better in "I_p

V107" position. Adjust C139 "OUTPUT TUNING" to obtain proper grid current in following amplifier or desired output, then retune C137 for dip or maximum output. (If a Micromatch or Reflectometer is used in the output transmission line, the developed DC voltage may be fed into the exciter via pin 8, of plug T105 and indicated on the meter, meter switch in "POWER OUTPUT" position.)

16. Adjust the sensitivity of the off-frequency detector (V116) as described in the following paragraphs.

NOTE CAREFULLY: This adjustment is important to assure sufficient pull-in range of the exciter.

Then proceed with Steps 17, 18, 19 and 20.

"OFF-FREQUENCY INTERLOCK" Adjustment

Sensitivity of the off-frequency detector (V116) is controlled by the setting of the "OFF-FREQUENCY INTERLOCK SENSITIVITY" potentiometer (R174) in the cathode circuit of this stage. Proper adjustment can be obtained by use of either a 35 cps or 50 cps tone source, although the methods differ slightly as follows:

Using a 35-cycle tone, modulate the exciter 130%. An input signal of approximately +13 db is required. Turn R174 counter-clockwise until relay K101 is energized, as observed by listening for the closing of the relay or by operation of the PA plate or screen cutout. The point at which relay K101 is energized will be the correct setting for R174.

If a 35 cps source is not available, an alternate method using a 50-cycle tone source may be used. Modulate the exciter 130% with the 50-cycle tone, and turn R174 counter-clockwise to the point where K101 is energized. Note this setting. Then turn R174 clockwise until K101 is de-energized, noting this setting. Then set R174 halfway between these energized and de-energized positions, which will be the

correct adjustment. Check for proper off-frequency control action by switching the "AFC SWITCH" (S101) to "OFF" and slightly detuning the vernier control on the top of T103. This should energize relay K101. Retune T103 to original setting.

17. Set CRO-Switch (S106) to "PHASE DET" position and reduce "INTENSITY" (R185) to prevent burn-in of the pattern.

18. Finally, using the station frequency monitor tune the crystal "FREQUENCY ADJUSTMENT" trimmer capacitors (C205) and (C206) to the assigned center frequency. (C205 or C206 will vary final frequency approximately ± 15 kc.)

NOTE: Frequency can be changed slightly by adjustment of L112 also. Do not change more than ± 2 kc.

19. Reduce "INTENSITY" (R185) as much as possible to prevent CRT "burn-in".

20. Multiplex Operation. Best crosstalk will be obtained with all multiplier and amplifier stages tuned for maximum grid current in the following stage or for maximum power.

OPERATION

In daily operation of the equipment, the crystal heaters should be left on continuously. Then after application of power to the exciter, and allowing a short warm-up period, performance can be checked by observing the patterns on the oscilloscope while the exciter is on the air.

The oscillograms shown with the tuning procedure in the INSTALLATION section of this book represent the desired adjustment of the various stages of the exciter for proper operation of the AFC system. These oscilloscope patterns may be observed during regular operation without affecting performance of the exciter.

The 75 μ s pre-emphasis network is a plug-in unit and can be removed if it is desired to apply pre-emphasis at some other point in the system. If this unit is removed, an 18 db pad should be inserted in place of the pre-emphasis network. Such an attenuator can be made up in accordance with Figure 8. Numbers on the diagram identify the octal pins of the socket XZ101. The use of $\pm 5\%$ tolerance, $\frac{1}{2}$ watt resistors is recommended.

Output Frequency Conversion

A conversion coil (MI-34501-2) is supplied with the exciter to modify the last stage to a straight-

through amplifier, providing an output frequency in the range of 44 to 54 mcs. If the exciter is to be used with previously designed FM transmitters incorporating a frequency doubler, this modification should be made in the exciter.

If it is necessary that the exciter operate on one-half of the final frequency, modification of the output stage should be made in accordance with the following procedure using the conversion coil.

1. Remove all power from the exciter unit. Remove the cover enclosing components of the final stage, and remove the 6146 tube (V107).

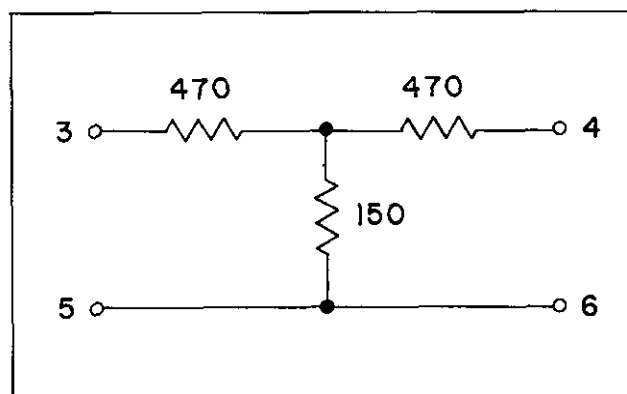

Figure E-8. Schematic, 18 db Attenuator

2. Unsolder the r-f choke (L107) from the feed-through capacitor (C146), and remove units that hold the plate component mounting bracket in place. The bracket can then be turned to gain access to screws holding the plate coil (L106). Remove this coil, and install the new coil (MI-34501, Item 2) in its place.

3. Put mounting bracket back in place, making sure all mounting screws are tight. Re-solder L107 and C146 in such a way that there will be at least 1/2-inch clearance between L107 and the cover when the cover is in position.

4. Reinsert tube V107 in its socket, and install the cover in place. This completes the modification. Filament and plate power can now be applied. With the modification made, power output will be between 10 and 15 watts.

NOTE: In an emergency, the RCA 6146 (V107) may be replaced by an RCA 2E26, at somewhat reduced power output, should the latter tube be more readily available. No change in connections is required.

Main Carrier Deviation by the Subcarrier

Approximate deviation of the main carrier can be set without a monitor, using only a subcarrier generator and the chart shown in Figure 9. The chart indicates the amount of subcarrier voltage necessary

at the input of the BTE-10B Exciter (J-102 or J-106) to produce the required deviation.

As indicated on the chart, the higher subcarrier frequencies require slightly more voltage than the lower frequencies. To obtain a ± 10 kc deviation of the main carrier at 67 kc, 3.6 volts should be selected. At a 32.5 kc, 2.6 volts will produce the same main channel deviation.

The above method is approximate and subject to tolerances in the order of ± 25 percent. It is recommended that the reactance tube V-104 be compared with 2 or 3 other 6CL6 tubes. One method of doing so is by measuring relative subcarrier voltage. A multiplex receiver (with main program off) should produce a voltage of 0.1 to 0.2 volts at the discriminator with ± 15 kc deviation of the main by the subcarrier. Using several 6CL6 tubes this voltage should remain the same.

Proper setting of L-104 in the BTE-10B (maximum grid current into the 2nd tripler) will coincide with minimum subcarrier deviation of the main channel. Detuning of L-104 will increase crosstalk as well as subcarrier deviation of the main carrier. Therefore, L-104 should be set to maximum grid current into the following tripler stage for minimum crosstalk.

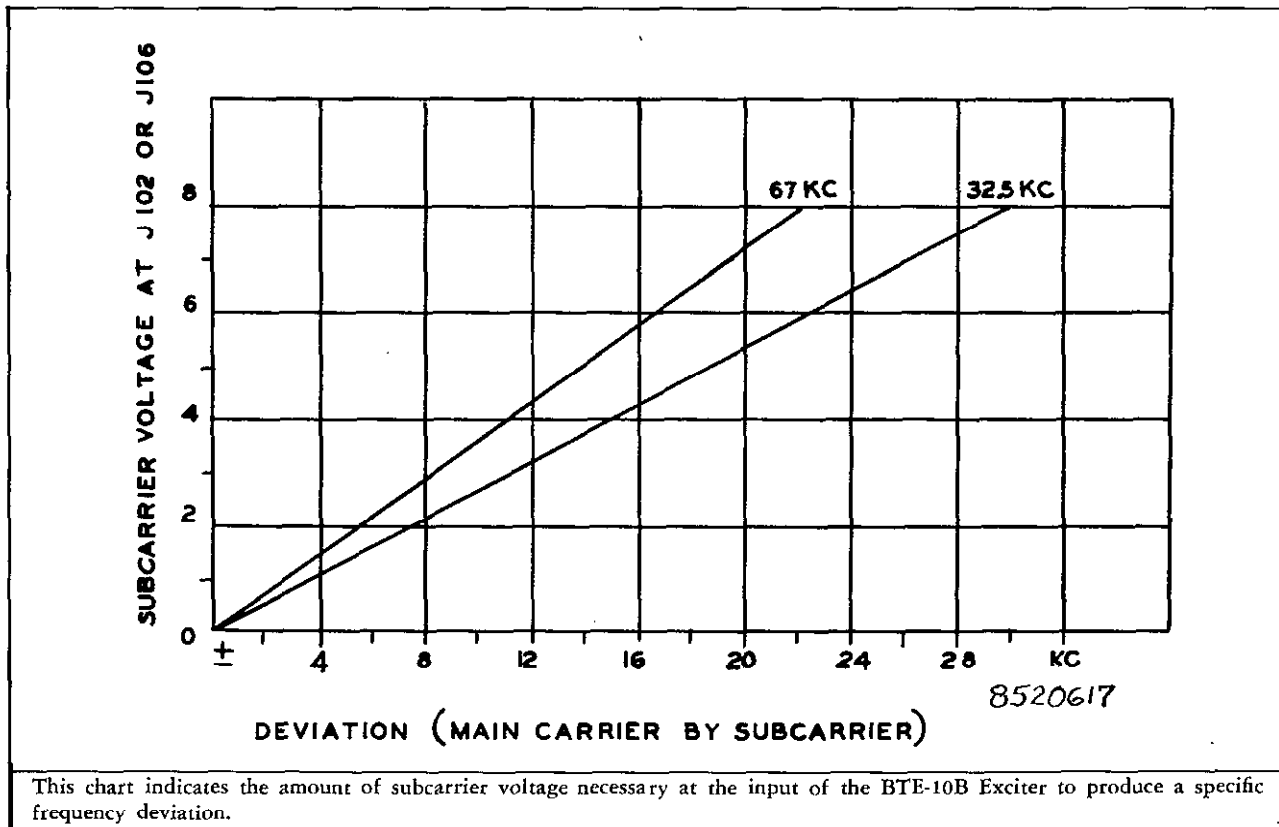

This chart indicates the amount of subcarrier voltage necessary at the input of the BTE-10B Exciter to produce a specific frequency deviation.

Figure E-9. Main Carrier Deviation by the Subcarrier (Chart)

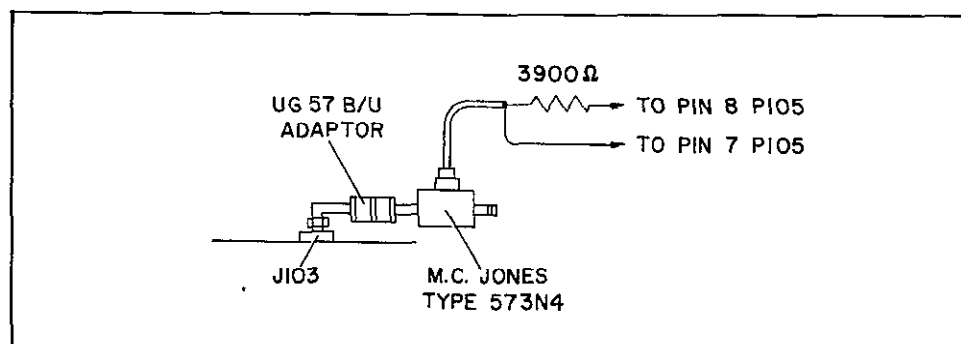

Figure E-10. Connections for Measuring Power Output

Subcarrier Modulation

To increase subcarrier modulation percentage, a 47K ohm, $\frac{1}{2}$ watt resistor should be connected in parallel to R195 or R197.

Use of Control Tones

The exciter can be modulated by control tones if

desired. These control tones, which are generally in the range between 20 kc and 35 kc, should be fed into one of the subcarrier input jacks (J106) on the exciter. With approximately 5 volts as measured at this point, 30% modulation of the main carrier will be obtained.

MAINTENANCE

With normal care, no maintenance should be required except a periodic check of all tubes and replacement of defective ones with new tubes of the same type.

Failure of automatic frequency control due to the failure of a tube or other component will be evidenced by operation of the relay K101 in the off-frequency detector circuit, opening the contacts (Terminals No. 5 and No. 6 of J105) that control the PA stage of the transmitter. If failure is due to a defective tube, proper operation of the exciter will be restored by replacement of the defective tube without need for readjustment. However, if replacement of circuit components is made, it will be necessary to realign the exciter following the procedure for tuning presented under INSTALLATION.

Emergency Operation

Provision is made for maintaining frequency control should tubes or components associated with the automatic frequency control fail. The operator will be warned of the loss of control by loss of carrier, or by the erratic performance of the carrier frequency monitor.

Tube or component failure can be found in some cases by switching the meter switch (S102) through each of its positions until an abnormal reading is found identifying the difficulty. The oscilloscope switch (S106) may also be helpful in locating trouble in the AFC circuits.

If the master oscillator is functioning, the output carrier frequency can be controlled manually as follows, until such time as repairs can be made:

1. Remove the 2D21 "OFF-FREQUENCY" control tube (V116).
2. Turn the "AFC-OFF" switch (S101) to "OFF".
3. Slowly rotate the top adjustment screw of T103 in first one direction and then the other to bring the output frequency to its assigned value as indicated by the frequency monitor.

Stability of the master oscillator without AFC is such that after sufficient warm-up it maintains frequency to ± 1 kc (at the final frequency) for short periods of time. Possible drift can be corrected by adjustment of T103 top screw.

CAUTION: The voltage of the filament d-c power supply will vary with load. Therefore, care should be taken not to remove more than two of the tubes having d-c on the filament. Otherwise, damage to the remaining d-c heated tubes or to C202 may result.

Power Output Measurements

Power output indications can be obtained conveniently by use of the meter (M101) and a suitable coupler such as the M. C. Jones Micromatch. With the meter switch (S102) in the "POWER OUTPUT" position, the positive terminal of the meter is connected to Pin No. 7 (ground) of P105 and the negative terminal to Pin No. 8 of P105. Readings obtained

will depend upon the type of coupler used. With an M. C. Jones Type 573N4 and a UG57B/U adaptor, a 3900-ohm resistor in series with the meter will provide mid-scale reading of the meter at ten watts output. Connections should be made as shown in Figure 10.

The parasitic suppressor R138-L113 is not required whenever tube V107 is operated as a doubler. In an application where maximum possible output power is desired, R138-L113 may be removed.

Additional power may be obtained by shorting out R132. Under such conditions, however, V107 should not be operated without r-f excitation. Lack of excitation will increase the plate current of V107 to a point where S103 will be energized.

To make tuning more practical, a switch should be placed across R132. This switch will be closed

only after sufficient drive has been obtained, as indicated by M101 in the V107 I position.

TYPICAL METER READINGS

Meter (M101) Position	Function	Reading	
		88 mc	108 mc
V101 & V102 I _k	Modulators	63	64
V106 I _c	2d Freq. Tripler	39	35
V107 I _c	Doubler & PA	41	35
V107 I _k	Doubler & PA	68	66
+AFC	Control Voltage	<10	<10
-AFC	Control Voltage	<10	<10
V107 E _p	Doubler & PA	62	62
V107 I _p	Doubler & PA	49	48
POWER OUTPUT	PA	(see text)	

TYPICAL TUBE SOCKET VOLTAGES* BTE-10B FM Exciter

Tube		P i n N o .										
Symbol	Type	1	2	3	4	5	6	7	8	9	10	11
V101	6AQ5	.2	15.5	0	6.4	150	150	.2	—	—	—	—
V102	6AQ5	0 ¹	15.5	0	6.4	150	150	0 ¹	—	—	—	—
V103	6AQ5	-17	0	0	6.4	150	70	-17	—	—	—	—
V104	6CL6	7.6	0	150	0	6.4	150	7.6	150	0	—	—
V105	5763	320	—	10	0	6.0	270	10	-25	-25	—	—
V106	5763	320	—	10	0	5.9AC	270	10	-2.2 ²	-2.2 ²	—	—
V107	6146	48	6.3AC	225	48	-2.8 ³	48	0	0	—	—	—
V108	6AH6	-4.5	75	0	6.3AC	75	75	0	—	—	—	—
V109	6AH6	-8	90	0	6.3AC	90	90	0	—	—	—	—
V110	6AH6	-13	95	0	6.3AC	95	95	0	—	—	—	—
V111	6AH6	-7	100	0	6.4	100	100	0	—	—	—	—
V112	6AU6	-9.5	0	0	6.3AC	145	70	0	—	—	—	—
V113	6AH6	-7	88	0	6.4	88	-7	0	—	—	—	—
V114	12AT7	240	.5	4.3	0	0	240	-1	4.2	6.4	—	—
V115	6AS6	0	2.2	0	6.3AC	120	85	0	—	—	—	—
V116	2D21	0 1.5AC ⁴	2.7 ⁵	0	6.3AC	2.7 ⁵	145AC ⁴ -100	2.7 ⁵	—	—	—	—
V117	OD3	— ⁶	2.4	—	150	150	—	—	—	—	—	—
V118	1EP1	0	6.3AC	2.5 ⁷	9	80 ⁸	— ⁹	320	320	— ⁹	320	—

* Voltages measured with VTVM against ground; values are positive except where marked otherwise.

¹May vary $\pm 1V$ due to AFC. If more than +1V or -1V, correct setting of T103.

²Measure at junction of R126 and R127.

³Measure at junction of R130 and R131.

⁴Figures above line: relay de-energized; below line: relay energized.

⁵Depends on setting of R174. Typical value shown.

⁶Do not take reading.

⁷Depends on setting of R185. Typical value shown.

⁸Depends on setting of R183. Typical value shown.

⁹Reading difficult, due to large value of R187 and R188.

TROUBLE SHOOTING HINTS

RECOMMENDED TROUBLE SHOOTING EQUIPMENT

<i>Equipment</i>	<i>Type</i>
Vacuum Tube Voltmeter with RF Probe	RCA Voltomyst WV-98A with WG-301A Probe or Heath V-7A with Probe #309C or Equivalent
Audio Oscillator	Hewlett-Packard 206A or Heath AG-9A or Equivalent
Oscilloscope	RCA WO-88A with WG-300A Probe or Heath 0-12 with Probe PK-1 or Equivalent
Receiver	National NC-109 or Equivalent
Grid Dip Meter	Measurements Corp. #56 Heath GD-1B

The BTE-10B Exciter consists of the sub-units listed below; trouble shooting the exciter should follow in the order as given below.

- (1) Power Supply (V117)
- (2) RF Portion (Tubes V101 to V107)
- (3) Oscilloscope (V118)
- (4) AFC (Tubes V108 to V114)
- (5) Off Frequency Control (Tubes V115 and V116)

1. Power Supply

With S104 closed, check voltage at pin 5 of XC202. This voltage should be 6.3 volts DC $\pm 5\%$, and positive with relation to ground.

The AC voltage at pins 10 and 11 of T114 should be 6.3 volts, and between pins 7 and 9, 22 volts.

With S103 closed, check voltage at pin 5 of V117. It should read +150 volts. To check current through V117, measure the DC voltage across R194. Multiply this reading by 10 to get the current through the tube. This current should be between 15 and 25 ma. The voltage across R194 should be 1.5 to 2.5 V DC. The voltage across C200 can be read on M101 with switch S102 in the V107 E_p position. Multiply the reading on M101 by 5 to get the actual voltage. The AC voltage at pins 7 and 8 of T113 should be 370 volts.

S103 will trip at approximately 400 ma through control winding (C to D).

If proper voltages are available from the power supplies, proceed to the next section.

2. R-F Section

Switch S101 to AFC-OFF position.

Check pin voltages of V103 as given in table of Typical Tube Socket Voltages for BTE-10B FM

Exciter. The voltage on pin 1 should be measured using a 1 megohm isolation resistor (this resistor is part of the DC probe of the VTVM recommended in the Trouble Shooting Equipment Chart). If the voltage across R116 is very small the tube is not oscillating and another tube should be tried.

Next, measure the r-f voltage across pins A and D of coil T103. Approximately 2 V rms should be present. Use VTVM with RF-probe. Tune C105 for a peak reading on M101 with the selector switch in the V101 and V102 I_k position. When peaked, 7 V rms (r-f voltage) should be present on pins 1 and 7 of V101 and of V102.

The r-f voltage on pin 5 of V101, V102, and V103 is 100 volts. On terminal E of T103 the voltage is 35 volts. These voltages cannot be measured with the recommended VTVM since there is a limitation of 20 V rms for the r-f probe.

Check pin voltages of V104. There is no adjustment that will effect these voltages.

Check pin voltages of V105. If there is no voltage on pin 8 and 9, try a new tube and check C121. Tune L104 for maximum grid current into V106. If no grid current can be obtained, try a new V106 or check whether L104 and C125 resonate at 3 times the oscillator frequency. Use grid dip meter (exciter plate voltage off and dip meter in CW position) or use the receiver tuned to 3 times the oscillator frequency, and couple the antenna input loosely to pin 1 of V105. Set IF gain of the receiver such that the S2 reading is obtained on the S-Meter. Try to increase this indication by tuning L104.

Proceed in the same way with the second tripler V106. For frequencies above 100 mc, C214 should be removed.

To check the PA, a 10 watt dummy load should be made up using 5 resistors (composition type) of 270 ohm, 2 watts in parallel.

At 10 watts output the r-f voltage across this 54 ohm load should be 23 volts rms.

Refer to Off-Frequency Detector section for test with modulation on.

3. Oscilloscope

It should be possible to get some trace on the face of V118 irrespective of the setting of S106. Check V118 pin voltages if necessary, and make sure that the tube is properly inserted in the tube socket. Adjust R185 and R183. If it is not possible to reduce the intensity to zero with R185, a 1.5 megohm 1 watt resistor should be connected from pin 4 to pin 8 of V118.

4. AFC

Check the pin voltages of tube V112. In order to oscillate, L112 and the associated capacitors (C176, C204, and C203) should resonate at a frequency approximately 50% higher than the crystal used. (See table for BTE-10B Exciter Crystals.) When V112 is properly oscillating, the following r-f voltages (measure with VTVM and r-f probe) should be measured: 3.5 volts rms at terminal B of L112; 6.5 volts rms at pin 5 of V112, and 1.5 volts rms at pin 1 of V112.

The above voltages are nearly sinusoidal in character. Once V112 oscillates properly, the crystal divider can be locked in. This will produce a steady pattern on the oscilloscope with S106 in the CRYSTAL DIV position.

The following waveforms and voltages can be observed: Pin 1 of V113 should be 17 volts peak-to-peak, somewhat resembling a negative half wave; and a 140 volt peak-to-peak distorted sinewave at pin 5 of V113. At terminal A of T109 a 27 volt rms sine-wave can be measured. The VTVM in the AC position should be used since the frequency at T109 is between 20 and 25 kc. The voltage at terminal D of T109 is 7 volts rms. This signal can be followed to terminal 1 of T110 where 5 volts rms should be read.

The same procedure should be followed for the other divider chain, V108 through V111. The waveform appearing at the plate of all tubes will be symmetrical and look like a distorted sinewave. All grid waveforms are clipped sinewaves with only the negative portion remaining. The clipping and distortion is less pronounced in the first and second dividers. The peak-to-peak AC voltages at the grids of the first, second, etc., dividers are: 5.0, 14, 28 and 24 volts respectively. The plate AC peak-to-peak voltages of the dividers are 50, 140, 220 and 160 volts respectively.

At terminal D of T108, 14 volts peak-to-peak should be measured; at terminal 1 of T111 the rms voltage should be 3 volts.

With the master oscillator right on frequency, the DC voltage at the junction of L108 and R168 should be very close to zero with the AFC switch in the ON position. With AFC off, and S106 in the PHASE DET. Position, a slowly turning circle will be obtained at the CRT. In synchronism with the slowly turning circle a very low-frequency AC voltage should appear across the phase detector output. This voltage can be observed at M101 with S102 in the plus or minus AFC position. If the final frequency (the assigned frequency of the station) is off center by 4320 cps, Meter M101 will swing from maximum

positive to maximum negative and return to maximum positive indication in 1 second. The meter should show a maximum reading of $\pm 80\%$ on its dial, representing ± 8 volts at the junction of L108 and R168. If less than ± 8 volts is obtained, check the AC voltages into T110 and T111, and if these voltages are correct, check diodes CR101 and CR102.

With the AFC ON, it should be possible to detune T103 (rear adjustment) up to a point where M101 reads steadily $\pm 80\%$ in the \pm AFC position without loss of AFC action.

If control is lost before reading a $\pm 80\%$ indication check, (without retuning T103) which divider is unlocked and retune the particular divider slightly; then bring T103 back to center frequency and try detuning again.

Once control is lost, the exciter will not pull back on frequency unless T103 is tuned back to nearly "zero" frequency. To widen the range of pull-in action, an off-frequency detector has been added which is covered in the following section.

5. Off-Frequency Detector

With the AFC operating properly, the two frequencies fed to the grids (pins 1 and 7) of V115 will be identical, and no difference frequency appears at the plate. The original frequencies and the sum of the two original frequencies are eliminated by C193.

If control is lost, a difference beat appears which triggers V116 and then closes K101. This will cause a low frequency sweep of the oscillator to lock the AFC in.

The pull-in range of the AFC system with Off-Frequency Detector inoperative is ± 100 kc at the final frequency, and with the Off-Frequency Detector operating it is ± 350 kc.

To test the operation of the Off-Frequency Detector, switch AFC to the off position and adjust T103, (top adjustment) for stationary circle on the CRT in phase detector position. Then detune T103 (top adjustment) to give a circle "moving around" several times per second. This should close K101; if necessary adjust R174. With AFC ON, detune T103 until a reading of +40 is obtained on M101 in the +AFC position. Switch AFC OFF and then ON again. The AFC should be re-established within a few seconds. When the circle becomes stationary, the opening of K101 will cause a slight "jump" which can easily be observed. Repeat the above step in the negative direction. As a final check, modulate the transmitter 130% with 50 cycle tone. This should *not* close K101.

To check the range of the vernier control (top of T103), bring it all the way in and read \pm AFC volt-

age (e.g., +25) then take it all the way out and read AFC voltage again (e.g., -15). The sum of the absolute value of both readings should be 40 or more. If this range is not obtained, loosen lock-nut on handle and unscrew the handle to allow deeper penetration of vernier core. Then reset locknut.

To check quickly whether V101 and V102 are properly modulating the carrier, feed a +10 db sig-

nal at 30 cps to J101. (This will produce 2.45 volts across J101; .62 volts from pins 5 to 3 at XZ101; .08 volts from terminal 6 to 15 of T101; and .245 volts from terminal 4 to 14 or 10 to 13 of T101.) This modulation should cause very noticeable broadening of the circle on the CRT in the PHASE DET. position. A 30 cps voltage can also be found (use Oscilloscope) at junction of L108-R168 as well as at pin 5 of V115.

NOTES

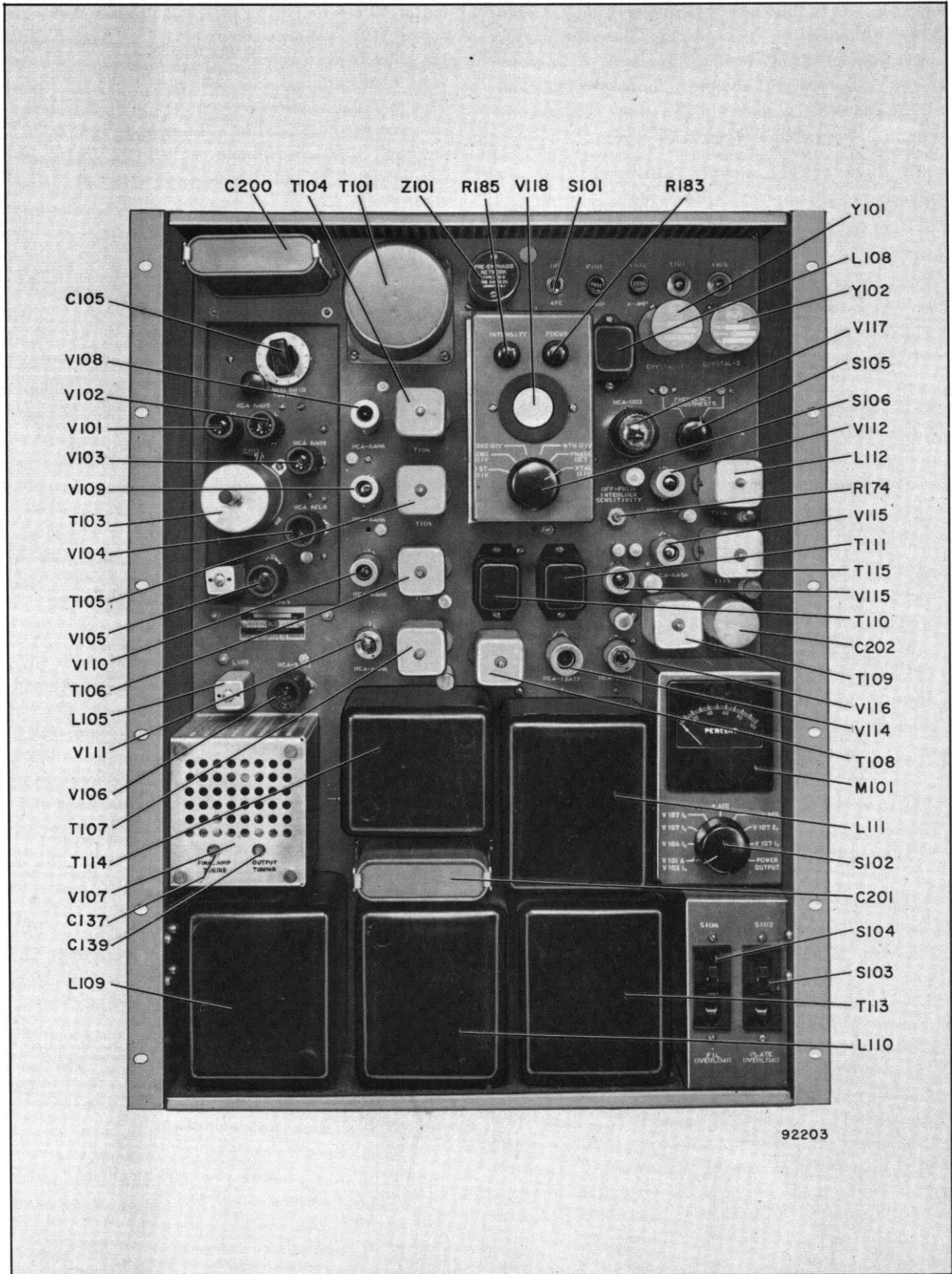

Figure E-11. BTE-10B FM Exciter, Front View

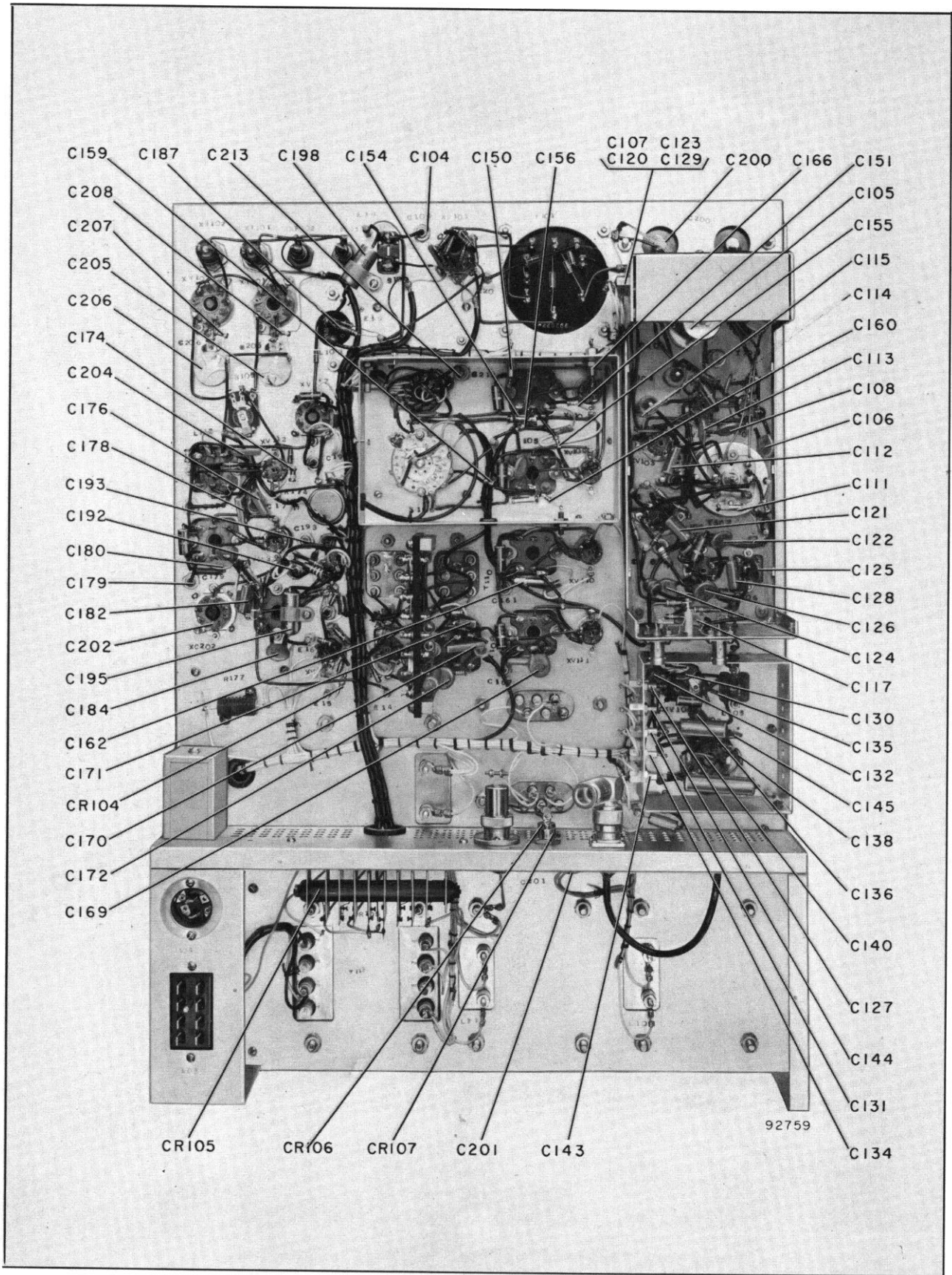

Figure E-13. BTE-10B FM Exciter, Rear View

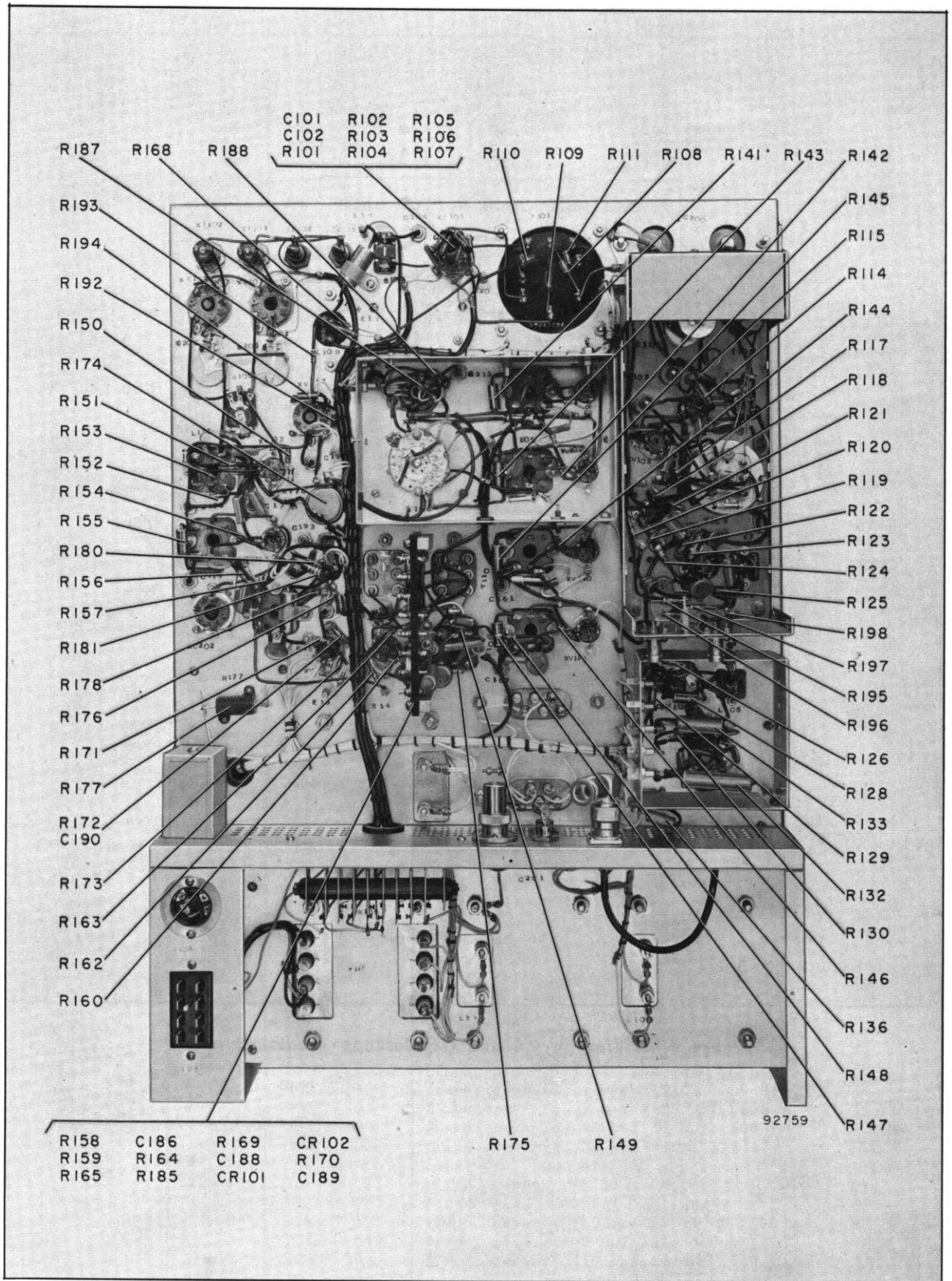

Figure E-14. BTE-10B FM Exciter, Rear View

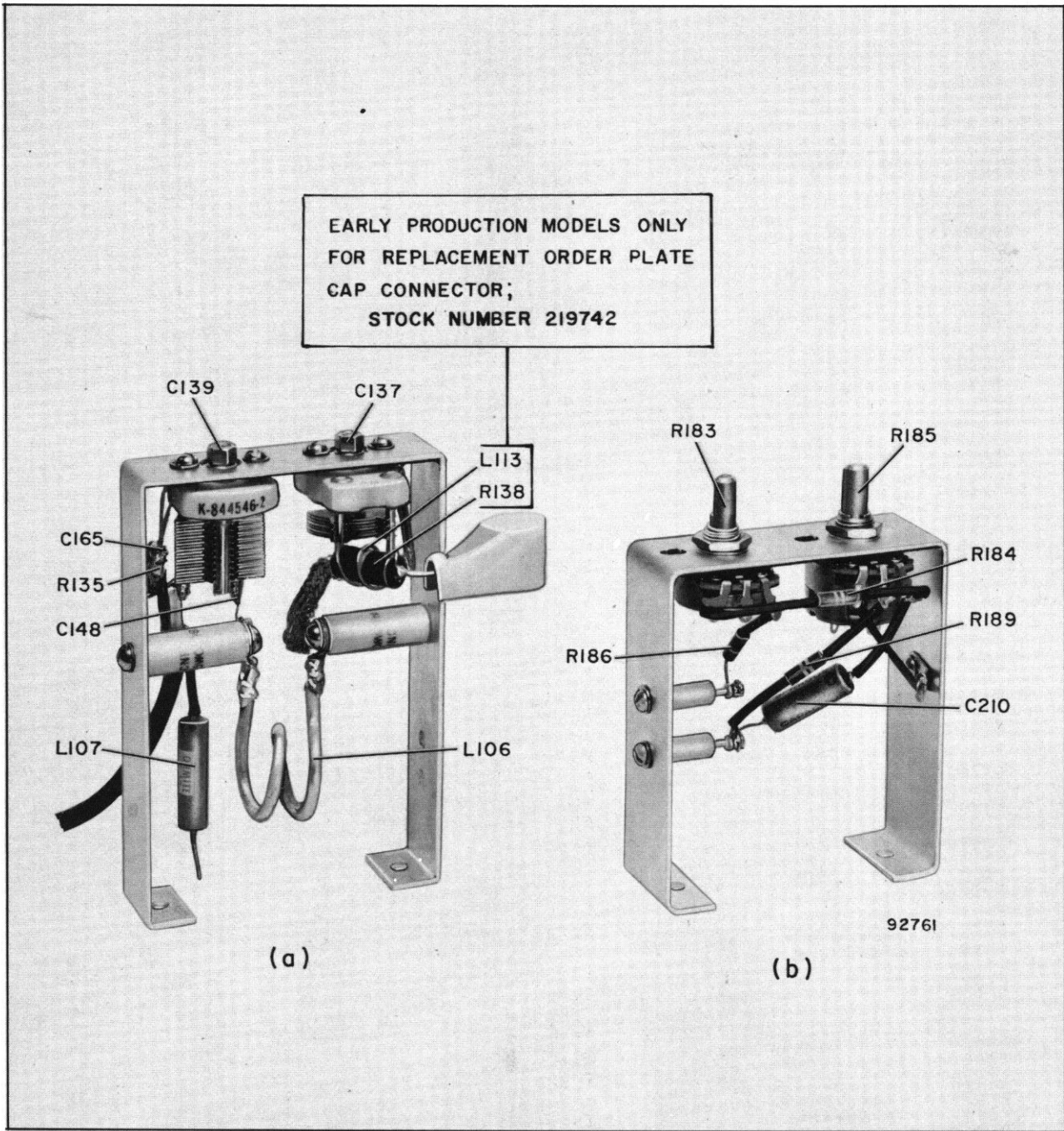

Figure E-15. View of PA and Oscilloscope Subassemblies

LIST OF PARTS

Symbol No.	Stock No.	Drawing No.	Description
EXCITER, MI-34501			
C101, C102	211170	737883-15	CAPACITORS: fixed, paper, .015 μ f \pm 10%, 100 v
C103		727856-131	fixed, mica, 220 μ f \pm 10%, 500 v
C104	211169	737863-87	fixed, paper, 1 μ f \pm 20%, 100 v
C105	45362	882321-1	variable, 6-140 μ f
C106	73960	990167-19	fixed, ceramic, .01 μ f -0 +100%, 500 v
C107	99177	8825449-1	feed-thru, .001 μ f, 500 v
C108	73960	990167-19	fixed, ceramic, .01 μ f -0 +100%, 500 v
C109, C110	77865	90575-309	fixed, ceramic, 10 μ f \pm 1 μ f, 500 v
C111	217541	90575-129	fixed, ceramic, 68 μ f \pm 2.5%, 500 v
C112		727856-145	fixed, mica, 820 μ f \pm 10%, 300 v
C113 to C115	73960	990167-19	fixed, ceramic, .01 μ f -0 +100%, 500 v
C116	217537	737863-25	fixed, paper, .1 μ f \pm 10%, 100 v
C117		727856-131	fixed, mica, 220 μ f \pm 10%, 500 v
C118	77252	990167-13	fixed, ceramic, .001 μ f -0 +100%, 600 v
C119		90575-315	fixed, ceramic, 18 μ f \pm 10%, 500 v
C120	99177	8825449-1	feed-thru, .001 μ f, 500 v
C121		727856-131	fixed, mica, 220 μ f \pm 10%, 500 v
C122	73960	990167-19	fixed, ceramic, .01 μ f -0 +100%, 500 v
C123	99177	8825449-1	feed-thru, .001 μ f, 500 v
C124	73960	990167-19	fixed, ceramic, .01 μ f -0 +100%, 500 v
C125	217565	458528-203	fixed, ceramic, 110 μ f \pm 5%, 500 v
C126	73960	990167-19	fixed, ceramic, .01 μ f -0 +100%, 500 v
C127	99177	8825449-1	feed-thru, .001 μ f, 500 v
C128		727856-133	fixed, mica, 270 μ f \pm 10%, 500 v
C129	99177	8825449-1	feed-thru, .001 μ f, 500 v
C130	73960	990167-19	fixed, ceramic, .01 μ f -0 +100%, 500 v
C131	99177	8825449-1	feed-thru, .001 μ f, 500 v
C132	73960	990167-19	fixed, ceramic, .01 -0 +100%, 500 v
C133		990575-359	fixed, ceramic, 5 μ f \pm 1 μ f, 500 v
C134	99177	8825449-1	feed-thru, .001 μ f, 500 v
C135	73960	990167-19	fixed, ceramic, .01 μ f -0 +100%, 500 v
C136		727856-133	fixed, mica, 270 μ f \pm 10%, 500 v
C137	44369	844546-10	variable, 4 - 25 μ f
C138	73960	990167-19	fixed, ceramic, .01 μ f -0 +100%, 500 v
C139	43368	844546-2	variable, 5- 75 μ f
C140	73960	990167-19	fixed, ceramic, .01 μ f -0 +100%, 500 v
C141, C142	73473	990167-17	fixed, ceramic, .0047 μ f -0 +100%, 500 v
C143, C144	99177	8825449-1	feed-thru, .001 μ f, 500 v
C145	73960	990167-19	fixed, ceramic, .01 μ f -0 +100%, 500 v
C146, C147	99177	8825449-1	feed-thru, .001 μ f, 500 v
C148	77953	990167-15	fixed, ceramic, 2200 μ f -0 +100, 500 v
C149	77865	990575-309	fixed, ceramic, 10 μ f \pm 1 μ f, 500 v
C150	99177	8825449-1	feed-thru, .001 μ f, 500 v
C151		90575-217	fixed, ceramic, 22 μ f \pm 5%, 500 v
C152, C153	73960	990167-19	fixed, ceramic, .01 μ f -0 +100%, 500 v
C154		90575-227	fixed, ceramic, 56 μ f \pm 5%, 500 v
C155, C156		90575-359	fixed, ceramic, 5 μ f \pm 1 μ f, 500 v
C157	73960	990167-19	fixed, ceramic, .01 μ f -0 +100%, 500 v
C158		90575-227	fixed, ceramic, 56 μ f \pm 5%, 500 v
C159	78928	90575-404	fixed, ceramic, 1.5 μ f \pm .25 μ f, 500 v
C160	77865	90575-309	fixed, ceramic, 10 μ f \pm 1 μ f, 500 v
C161	206332	737863-375	fixed, paper, .1 μ f \pm 20%, 400 v
C162	44700	90575-335	fixed, ceramic, 120 μ f \pm 10%, 500 v
C163	79992	90575-405	fixed, ceramic, 2 μ f \pm .25 μ f, 500 v
C164	77865	90575-309	fixed, ceramic, 10 μ f \pm 1 μ f, 500 v
C165		90575-321	fixed, ceramic, 33 μ f \pm 10%, 500 v
C166	99177	8825449-1	feed-thru, .001 μ f, 500 v
C167	213643	737863-381	fixed, paper, .33 μ f \pm 20%, 400 v
C168		727856-243	fixed, mica, 680 μ f \pm 5%, 500 v
C169	73960	990167-19	fixed, ceramic, .01 μ f -0 +100%, 500 v
C170		727860-248	fixed, mica, 1100 μ f \pm 5%, 300 v
C171	77865	90575-309	fixed, ceramic, 10 μ f \pm 1 μ f, 500 v

Symbol No.	Stock No.	Drawing No.	Description
C172	73960	990167-19	fixed, ceramic, .01 μ f -0 +100%, 500 v
C173	206332	737863-375	fixed, paper, .1 μ f \pm 20%, 400 v
C174		90575-225	fixed, ceramic, 47 μ f \pm 5%, 500 v
C175	206332	737863-375	fixed, paper, 1 μ f \pm 20%, 400 v
C176		727856-235	fixed, mica, 330 μ f \pm 5%, 500 v
C177	77865	90575-309	fixed, ceramic, 10 μ f \pm 1 μ f, 500 v
C178		727856-121	fixed, mica, 82 μ f \pm 10%, 500 v
C179	213643	737863-381	fixed, paper, .33 μ f \pm 20%, 400 v
C180	73960	990167-19	fixed, ceramic, .01 μ f -0 +100%, 500 v
C181		727856-243	fixed, mica, 680 μ f \pm 5%, 300 v
C182		727860-248	fixed, mica, 1100 μ f \pm 5%, 300 v
C183	77865	90575-309	fixed, ceramic, 10 μ f \pm 1 μ f, 500 v
C184	73960	990167-19	fixed, ceramic, .01 μ f -0 +100%, 500 v
C185, C186	211171	737883-75	fixed, paper, .1 μ f \pm 20%, 100 v
C187 to C189	211170	737883-15	fixed, paper, .015 μ f \pm 10%, 100 v
C190		727856-115	fixed, mica, 47 μ f \pm 10%, 500 v
C191	217539	737863-277	fixed, paper, .15 μ f \pm 20%, 300 v
C192	211169	737863-87	fixed, paper, 1 μ f \pm 20%, 100 v
C193	217564	737863-267	fixed, paper, .022 μ f \pm 20%, 300 v
C194	206332	737863-375	fixed, paper, .1 μ f \pm 20%, 400 v
C195	210909	737883-275	fixed, paper, .1 μ f \pm 20%, 300 v
C196	211169	737863-87	fixed, paper, 1 μ f \pm 20%, 100 v
C197	207757	442901-58	tubular electrolytic, 20 μ f -10 +100%, 150 v
C198	210874	737883-83	fixed, paper, .47 μ f \pm 20%, 100 v
C199	213643	737863-381	fixed, paper, .33 μ f \pm 20%, 400 v
C200, C201	211225	450184-5	fixed, paper, 16 μ f, 400 v
C202	211167	735712-6	fixed, electrolytic, 1500 μ f, 15 v
C203		727856-236	fixed, mica, 360 μ f \pm 5%, 500 v
C204		727856-145	fixed, mica, 820 μ f \pm 10%, 300 v
C205, C206	204066	258851-6	variable, ceramic, 6 - 25 μ f
C207, C208	77865	90575-309	fixed, ceramic, 10 μ f \pm 1 μ f, 500 v
C209	73960	990167-19	fixed, ceramic, .01 μ f -0 +100%, 500 v
C210	211171	737883-75	fixed, paper, .1 μ f \pm 20%, 100 v
C211, C212	73960	990167-19	fixed, ceramic, .01 μ f -0 +100%, 500 v
C213	210495	737863-371	fixed, paper, .047 μ f \pm 20%, 400 v
C214	77865	90575-309	fixed, ceramic, 10 μ f \pm 1 μ f, 500 v
CR101, CR102	59395	1N34A	Crystal - diode
CR103			Not Used
CR104	59395	1N34A	Crystal - diode
CR105	210347	8908824-4	Rectifier - plate
CR106, CR107	217571	8971903-2	Rectifier - filament
DS101, DS102	101857	872291-9	Lamp - neon
F101, F102	212327	8858508-6	Fuse - 0.5 amp
J101	211510	481799-2	Connector - female
J102	54890	445813-2	Connector - coaxial
J103	92180	433647-1	Receptacle - type N
J104	32660	889482-3	Receptacle
J105	55806	727969-7	Connector - male
J106	54890	445813-2	Connector - coaxial
K101	217572	627511-55	Relay - telephone type
L101	44679	862943-1	Choke - R.F.
L102	217573	8886161-13	Choke - R.F.
L103	44679	862943-1	Choke - R.F.
L104	211238	481715-4	Coil - R.F.
L105	217361	481715-6	Coil - R.F.
L106	217570	8959095-501	Coil - (Silver plated)
L107	57259	8886161-7	Choke - R.F.
L108	211164	8917198-1	Choke - R.F.
L109, L110	210637	476457-1	Reactor - filter
L111	210703	476473-1	Reactor - filter
L112	217356	728446-18	Coil - I.F.
M101	217558	477920-2	Meter - 0-100 microamps. D.C.
P101	211509	481799-1	Connector - male
P102	214186	427992-1	Connector - coaxial, male
P103	212885	8905991-1	Connector - male, coaxial

Symbol No.	Stock No.	Drawing No.	Description
P104	32661	878243-1	Connector - female
P105	55808	727969-8	Connector - female
P106	214186	427992-1	Connector - coaxial, male
			RESISTORS:
			<i>Fixed, Composition - unless otherwise specified</i>
R101, R102		82283-141	180 ohms $\pm 5\%$, $\frac{1}{2}$ w
R103		82283-147	330 ohms $\pm 5\%$, $\frac{1}{2}$ w
R104, R105		82283-141	180 ohms $\pm 5\%$, $\frac{1}{2}$ w
R106, R107		82283-133	82 ohms $\pm 5\%$, $\frac{1}{2}$ w
R108		82283-76	15,000 ohms $\pm 10\%$, $\frac{1}{2}$ w
R109, R110		82283-66	2200 ohms $\pm 10\%$, $\frac{1}{2}$ w
R111		82283-76	15,000 ohms $\pm 10\%$, $\frac{1}{2}$ w
R112, R113		82283-67	2700 ohms $\pm 10\%$, $\frac{1}{2}$ w
R114		90496-63	1200 ohms $\pm 10\%$, 1 w
R115		82283-147	330 ohms $\pm 5\%$, $\frac{1}{2}$ w
R116		82283-77	18,000 ohms $\pm 10\%$, $\frac{1}{2}$ w
R117		90496-86	100,000 ohms $\pm 10\%$, 1 w
R118		82283-80	33,000 ohms $\pm 10\%$, $\frac{1}{2}$ w
R119		82283-79	27,000 ohms $\pm 10\%$, $\frac{1}{2}$ w
R120		82283-74	10,000 ohms, $\pm 10\%$, $\frac{1}{2}$ w
R121		82283-64	1500 ohms $\pm 10\%$, $\frac{1}{2}$ w
R122		90496-85	82,000 ohms $\pm 10\%$, 1 w
R123		99126-55	270 ohms $\pm 10\%$, 2 w
R124	55186	867970-305	wire wound, 0.43 ohms $\pm 10\%$, $\frac{1}{2}$ w
R125		90496-76	15,000 ohms $\pm 10\%$, 1 w
R126		90496-85	82,000 ohms $\pm 10\%$, 1 w
R127		82283-163	1500 ohms $\pm 5\%$, $\frac{1}{2}$ w
R128		99126-55	270 ohms $\pm 10\%$, 2 w
R129		90496-76	15,000 ohms $\pm 10\%$, 1 w
R130		90496-79	27,000 ohms $\pm 10\%$, 1 w
R131		82283-159	1000 ohms $\pm 5\%$, $\frac{1}{2}$ w
R132	93933	458574-36	wire wound, 400 ohms $\pm 5\%$, 10 w
R133	217563	458572-85	wire wound, 16,000 ohms $\pm 5\%$, 5 w
R134		90496-121	27 ohms $\pm 5\%$, 1 w
R135		82283-74	10,000 ohms $\pm 10\%$, $\frac{1}{2}$ w
R136	217602	99316-3	wire wound, 5 ohm $\pm 1\%$, $\frac{1}{2}$ w
R137	55186	867970-305	wire wound, 0.43 ohms $\pm 10\%$, $\frac{1}{2}$ w
R138		99126-1	10 ohms $\pm 20\%$, 2 w
R139	217604	990185-395	film, 9530 ohms $\pm 1\%$, $\frac{1}{2}$ w
R140		82283-62	1000 ohms $\pm 10\%$, $\frac{1}{2}$ w
R141		99126-73	8200 ohms $\pm 10\%$, 2 w
R142		82283-62	1000 ohms $\pm 10\%$, $\frac{1}{2}$ w
R143		99126-73	8200 ohms $\pm 10\%$, 2 w
R144		82283-66	2200 ohms $\pm 10\%$, $\frac{1}{2}$ w
R145		99126-73	8200 ohms $\pm 10\%$, 2 w
R146		82283-66	2200 ohms $\pm 10\%$, $\frac{1}{2}$ w
R147		99126-73	8200 ohms $\pm 10\%$, 2 w
R148		82283-82	47,000 ohms $\pm 10\%$, $\frac{1}{2}$ w
R149		82283-84	68,000 ohm $\pm 10\%$, $\frac{1}{2}$ w
R150		82283-98	1 meg ohm $\pm 10\%$, $\frac{1}{2}$ w
R151		82283-86	100,000 ohms $\pm 10\%$, $\frac{1}{2}$ w
R152		82283-72	6800 ohms $\pm 10\%$, $\frac{1}{2}$ w
R153		82283-56	330 ohms $\pm 10\%$, $\frac{1}{2}$ w
R154		82283-66	2200 ohms $\pm 10\%$, $\frac{1}{2}$ w
R155		99126-73	8200 ohms $\pm 10\%$, 2 w
R156		82283-82	47,000 ohms $\pm 10\%$, $\frac{1}{2}$ w
R157		82283-84	68,000 ohms $\pm 10\%$, $\frac{1}{2}$ w
R158	78907	941799-17	wire wound, 4000 ohms $\pm 5\%$, 5 w
R159	93466	458572-97	wire w, und, 40,000 ohms $\pm 5\%$, 5 w
R160 to R162		82283-50	100 ohms $\pm 10\%$, $\frac{1}{2}$ w
R163		82283-86	100,000 ohms $\pm 10\%$, $\frac{1}{2}$ w
R164, R165		82283-59	560 ohms $\pm 10\%$, $\frac{1}{2}$ w
R166		82283-50	100 ohms $\pm 10\%$, $\frac{1}{2}$ w
R167		82283-86	100,000 ohms $\pm 10\%$, $\frac{1}{2}$ w

Symbol No.	Stock No.	Drawing No.	Description
R168		82283-98	1 meg ohm $\pm 10\%$, $\frac{1}{2}$ w
R169, R170		82283-183	10,000 ohms $\pm 5\%$, $\frac{1}{2}$ w
R171		82283-90	220,000 ohms $\pm 10\%$, $\frac{1}{2}$ w
R172, R173		82283-86	100,000 ohms $\pm 10\%$, $\frac{1}{2}$ w
R174	56596	458575-108	varibale, carbon, 2500 ohms $\pm 10\%$, 2 w
R175		82283-92	330,000 ohms $\pm 10\%$, $\frac{1}{2}$ w
R176		82283-82	47,000 ohms $\pm 10\%$, $\frac{1}{2}$ w
R177	217546	8914834-3	wire wound, 2000 ohms $\pm 3\%$, 25 w
R178		82283-82	47,000 ohms $\pm 10\%$, $\frac{1}{2}$ w
R179		82283-92	330,000 ohms $\pm 10\%$, $\frac{1}{2}$ w
R180		82283-78	22,000 ohms $\pm 10\%$, $\frac{1}{2}$ w
R181		90496-81	39,000 ohms $\pm 10\%$, 1 w
R182		82283-61	820 ohms $\pm 10\%$, $\frac{1}{2}$ w
R183	206044	433196-3	variable, .25 meg ohms $\pm 10\%$, 2 w
R184		82283-88	150,000 ohms $\pm 10\%$, $\frac{1}{2}$ w
R185	52837	433196-5	variable, 50,000 ohms $\pm 10\%$, 2 w
R186		82283-98	1 meg ohm $\pm 10\%$, $\frac{1}{2}$ w
R187, R188		82283-100	1.5 meg ohm $\pm 10\%$, $\frac{1}{2}$ w
R189		82283-95	560,000 ohm $\pm 10\%$, $\frac{1}{2}$ w
R190	217603	990185-468	carbon, film, 49,900 ohms $\pm 1\%$, $\frac{1}{2}$ w
R191	214810	990187-668	film, 4.99 megohms $\pm 1\%$, 1 w
R192		82283-175	4700 ohm $\pm 5\%$, $\frac{1}{2}$ w
R193		82283-206	91,000 ohm $\pm 5\%$, $\frac{1}{2}$ w
R194		90496-50	100 ohm $\pm 10\%$, 1 w
R195		82283-82	47,000 ohms $\pm 10\%$, $\frac{1}{2}$ w
R196		82283-74	10,000 ohm $\pm 10\%$, $\frac{1}{2}$ w
R197		82283-82	47,000 ohms $\pm 10\%$, $\frac{1}{2}$ w
R198		82283-74	Resistor - fixed, composition, 10,000 ohms $\pm 10\%$, $\frac{1}{2}$ w
S101	211166	8907253-2	Switch: toggle
S102	217560	8436501-1	Switch: rotary
S103	217566	849370-8	Switch: D.C. O.L.
S104	217552	8434096-1	Switch: A.C. O.L.
S105	52980	442389-2	Switch: rotary
S106	217559	8436500-1	Switch: rotary
T101	52685	902022-1	Transformer: input
T102	211180	897903-502	Coil Assembly
T103	219740	727590-507	Coil Assembly
T104	51738	728446-17	Transformer: 42.8 microhenry
T105	211182	728446-13	Transformer: 471 microhenry
T106	211183	728446-14	Transformer: 5652 microhenry
T107 to T109	211184	728446-15	Transformer: 34,500 microhenry
T110, T111	51734	442511-1	Transformer: input
T112	210660	481743-1	Transformer: power
T113	217362	8434093-1	Transformer: plate
T114	217357	8434095-1	Transformer: filament
T115	211184	728446-15	Transformer: 34,500 microhenry
XC202	217561	99390-3	Socket: octal, red
XDS101, XDS102		8856946-2	Socket: lamp
	94121		Jewel only
	56610		Socket only
XF101, XF102	48894	99088-2	Holder: fuse
XV101 to XV103	94879	737867-18	Socket: 7 pin miniature
XV104 to XV106	94880	737870-18	Socket: 9 pin miniature
XV107	54414	99390-1	Socket: octal
XV108 to XV113	94879	737867-18	Socket: 7 pin miniature
XV114	94880	737870-18	Socket: 9 pin miniature
XV115, XV116	94879	737867-18	Socket: 7 pin miniature
XV117	54414	99390-1	Socket: octal
XV118	217548	8944202-1	Socket: 11 pin
XY101, XY102	75061	746002-7	Socket: crystal
Y101, Y102			Crystal
XZ101	59919	746048-1	Socket: vector
Z101	219730	481755-3	Network: pre-emphasis
	219742	8815313-9	Miscellaneous: Connectbr: plate cap

<i>Symbol No.</i>	<i>Stock No.</i>	<i>Drawing No.</i>	<i>Description</i>
	211248	8817922-1	Dial: (C105)
	211244	8917263-1	Drive Unit: (tunes C105)
	208116	426765-12	Insulator: steatite, 3/8" dia. x 1" lg.
	30075	737820-507	Knob: 1" dia. (for S105)
	215877	737820-505	Knob: 1-1/2" dia. (for S102 and S106)
	213996	69916-10	Knob: 3/4" dia. (for R185)
	57692	8896313-1	Mount: shock mount
	217574	483884-9	Shield: tube, 7 pin (for 6AQ5)
	215853	483884-12	Shield: tube, 9 pin (for 6CL6, 5763)
	53016	99369-1	Shield: tube, 7 pin (for 6AS6)
	54521	99369-2	Shield: tube, 7 pin (for 6AU6)
	56359	8888549-2	Shield: tube, 9 pin, (for 12AT7)

NOTES

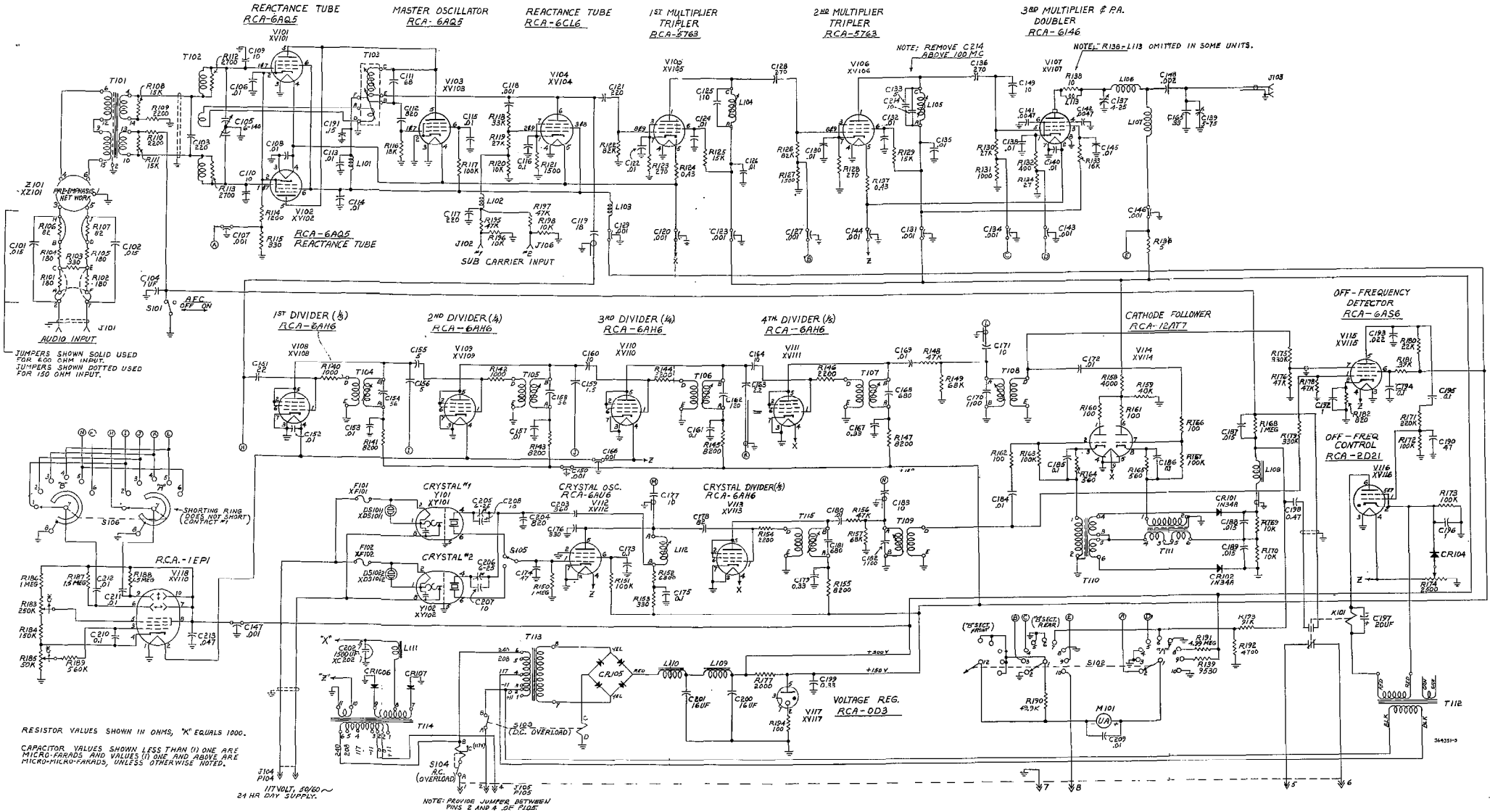
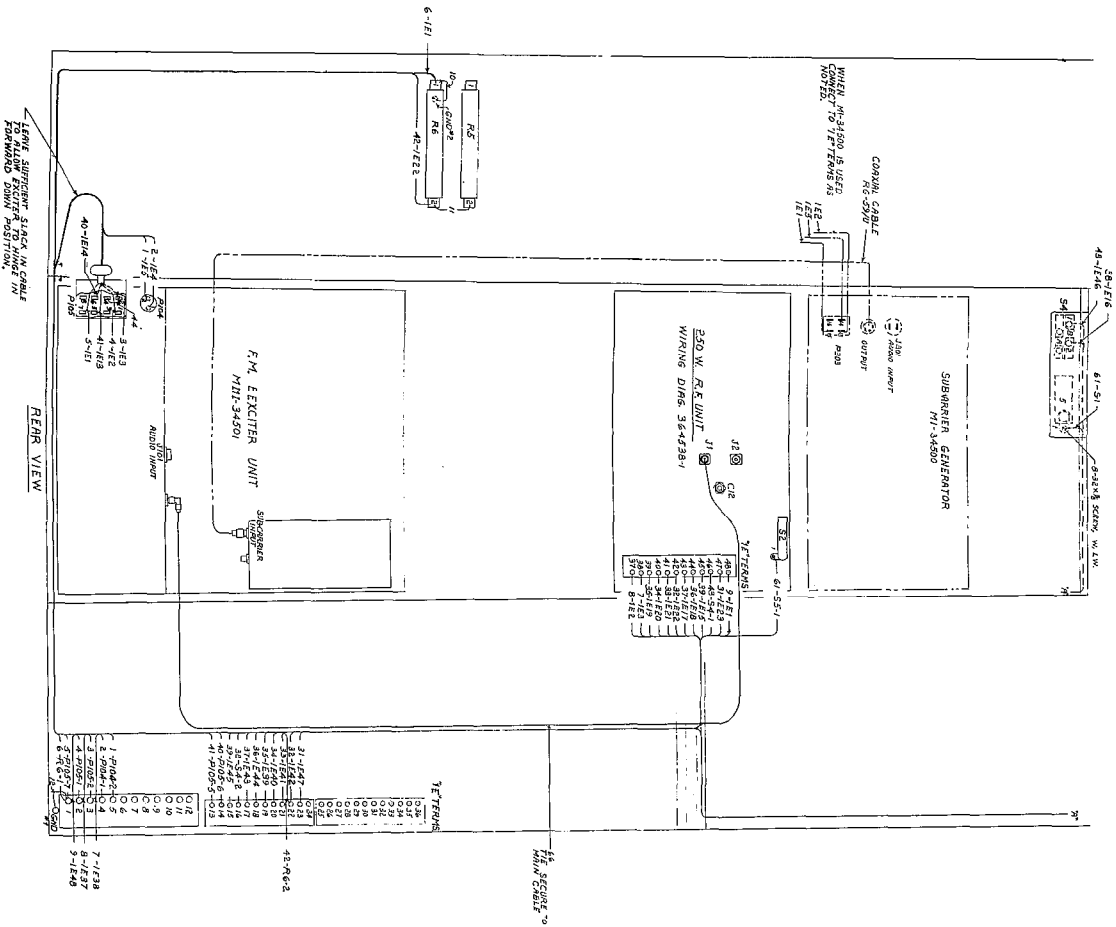

Figure E-16. Overall Schematic Diagram.
BTE-10B FM Exciter (364351)



WIRE NO. 1	DESCRIPTION	WIRE NO. 2	WIRE NO. 3
1	WIRE 200982-33	WIRE 1743	
2	WIRE 200982-33	WIRE 1743	
3	WIRE 200982-33	WIRE 1743	
4	WIRE 200982-33	WIRE 1743	
5	WIRE 200982-33	WIRE 1743	
6	WIRE 200982-33	WIRE 1743	
7	WIRE 200982-33	WIRE 1743	
8	WIRE 200982-33	WIRE 1743	
9	WIRE 200982-33	WIRE 1743	
10	WIRE 200982-33	WIRE 1743	
11	WIRE 200982-33	WIRE 1743	
12	WIRE 200982-33	WIRE 1743	
13	WIRE 200982-33	WIRE 1743	
14	WIRE 200982-33	WIRE 1743	
15	WIRE 200982-33	WIRE 1743	
16	WIRE 200982-33	WIRE 1743	
17	WIRE 200982-33	WIRE 1743	
18	WIRE 200982-33	WIRE 1743	
19	WIRE 200982-33	WIRE 1743	
20	WIRE 200982-33	WIRE 1743	
21	WIRE 200982-33	WIRE 1743	
22	WIRE 200982-33	WIRE 1743	
23	WIRE 200982-33	WIRE 1743	
24	WIRE 200982-33	WIRE 1743	
25	WIRE 200982-33	WIRE 1743	
26	WIRE 200982-33	WIRE 1743	
27	WIRE 200982-33	WIRE 1743	
28	WIRE 200982-33	WIRE 1743	
29	WIRE 200982-33	WIRE 1743	
30	WIRE 200982-33	WIRE 1743	
31	WIRE 200982-33	WIRE 1743	
32	WIRE 200982-33	WIRE 1743	
33	WIRE 200982-33	WIRE 1743	
34	WIRE 200982-33	WIRE 1743	
35	WIRE 200982-33	WIRE 1743	
36	WIRE 200982-33	WIRE 1743	
37	WIRE 200982-33	WIRE 1743	
38	WIRE 200982-33	WIRE 1743	
39	WIRE 200982-33	WIRE 1743	
40	WIRE 200982-33	WIRE 1743	
41	WIRE 200982-33	WIRE 1743	
42	WIRE 200982-33	WIRE 1743	
43	WIRE 200982-33	WIRE 1743	
44	WIRE 200982-33	WIRE 1743	
45	WIRE 200982-33	WIRE 1743	
46	WIRE 200982-33	WIRE 1743	
47	WIRE 200982-33	WIRE 1743	
48	WIRE 200982-33	WIRE 1743	
49	WIRE 200982-33	WIRE 1743	
50	WIRE 200982-33	WIRE 1743	
51	WIRE 200982-33	WIRE 1743	
52	WIRE 200982-33	WIRE 1743	
53	WIRE 200982-33	WIRE 1743	
54	WIRE 200982-33	WIRE 1743	
55	WIRE 200982-33	WIRE 1743	
56	WIRE 200982-33	WIRE 1743	
57	WIRE 200982-33	WIRE 1743	
58	WIRE 200982-33	WIRE 1743	
59	WIRE 200982-33	WIRE 1743	
60	WIRE 200982-33	WIRE 1743	
61	WIRE 200982-33	WIRE 1743	
62	WIRE 200982-33	WIRE 1743	
63	WIRE 200982-33	WIRE 1743	
64	WIRE 200982-33	WIRE 1743	
65	WIRE 200982-33	WIRE 1743	
66	WIRE 200982-33	WIRE 1743	
67	WIRE 200982-33	WIRE 1743	
68	WIRE 200982-33	WIRE 1743	
69	WIRE 200982-33	WIRE 1743	
70	WIRE 200982-33	WIRE 1743	
71	WIRE 200982-33	WIRE 1743	
72	WIRE 200982-33	WIRE 1743	
73	WIRE 200982-33	WIRE 1743	
74	WIRE 200982-33	WIRE 1743	
75	WIRE 200982-33	WIRE 1743	
76	WIRE 200982-33	WIRE 1743	
77	WIRE 200982-33	WIRE 1743	
78	WIRE 200982-33	WIRE 1743	
79	WIRE 200982-33	WIRE 1743	
80	WIRE 200982-33	WIRE 1743	
81	WIRE 200982-33	WIRE 1743	
82	WIRE 200982-33	WIRE 1743	
83	WIRE 200982-33	WIRE 1743	
84	WIRE 200982-33	WIRE 1743	
85	WIRE 200982-33	WIRE 1743	
86	WIRE 200982-33	WIRE 1743	
87	WIRE 200982-33	WIRE 1743	
88	WIRE 200982-33	WIRE 1743	
89	WIRE 200982-33	WIRE 1743	
90	WIRE 200982-33	WIRE 1743	
91	WIRE 200982-33	WIRE 1743	
92	WIRE 200982-33	WIRE 1743	
93	WIRE 200982-33	WIRE 1743	
94	WIRE 200982-33	WIRE 1743	
95	WIRE 200982-33	WIRE 1743	
96	WIRE 200982-33	WIRE 1743	
97	WIRE 200982-33	WIRE 1743	
98	WIRE 200982-33	WIRE 1743	
99	WIRE 200982-33	WIRE 1743	
100	WIRE 200982-33	WIRE 1743	

Figure E-17. Interconnection Diagram, BTE-108/BTX-1A (364539)

364539-4



RADIO CORPORATION OF AMERICA
INDUSTRIAL ELECTRONIC PRODUCTS, CAMDEN, N. J.