

Quantum Mechanics II

In November, 1925, Schroedinger gave a seminar in Zurich on the wave notions of de Broglie. There, Debye suggested that a wave equation might exist that captured de Broglie's ideas. Within a few weeks, Schroedinger proposed his famous wave equation.



$$i\hbar \frac{\partial \psi(x, t)}{\partial t} = -\frac{\hbar^2}{2m} \frac{\partial^2 \psi(x, t)}{\partial x^2} + V(x)\psi(x, t)$$

Here, $\psi(x, t)$ is the time-dependent wave function, and

$$\hbar \text{ (h bar) } = \frac{h}{2\pi} \quad i = \sqrt{-1}.$$

$\psi(x, t)$ is determined by solving this equation for a given potential $V(x)$. For reasons that will become clear, $V(x)$ is assumed to be real, but, given the factor i , $\psi(x, t)$ is, in general, complex.

$$\text{For } \psi \sim e^{i(kx - \omega t)} = e^{\frac{i}{\hbar}(px - Et)}$$

$$i\hbar \frac{\partial}{\partial t} \psi = (i\hbar) \frac{i}{\hbar} (-E) \psi = E \psi$$

$$\frac{\partial}{\partial x} \psi = \left(\frac{i}{\hbar} p\right) \psi$$

$$\frac{\partial^2}{\partial x^2} \psi = \left(\frac{i}{\hbar} p\right) \left(\frac{i}{\hbar} p\right) \psi = -\frac{1}{\hbar^2} p^2 \psi$$

$$-\frac{\hbar^2}{2m} \frac{\partial^2}{\partial x^2} \psi = \frac{p^2}{2m} \psi$$

$$\Rightarrow \hat{E} \psi = \left(\frac{\hat{p}^2}{2m} + \hat{V} \right) \psi$$

The time-dependent Schrodinger equation is said to be a linear equation because if $\psi_1(x,t)$ and $\psi_2(x,t)$ are solutions, $\psi(x,t) = a_1 \psi_1(x,t) + a_2 \psi_2(x,t)$, where a_1 and a_2 are complex numbers, is also a solution. The idea of adding solutions together to obtain another solution is called superposition.

Since observables such as position, momentum, energy, etc. are real numbers, the interpretation of $\psi(x,t)$ must be carefully considered.

To get an idea of how to proceed, remember that a complex number has the form

$$z = x + iy,$$

where x and y are real numbers. To form a real number associated with z , complex conjugation is introduced as

$$z^* = x - iy,$$

and then $z^*z = |z|^2$ is real

$$z^*z = (x - iy)(x + iy) = x^2 + y^2 \geq 0.$$

Now $|\psi(x,t)|^2$ is real and if $|\psi(x,t)|^2 dx$ is interpreted as the probability that x lies between x and $x+dx$, we must have

$$\int_{-\infty}^{\infty} dx |\psi(x,t)|^2 = 1,$$

for all times t . In other words, the Schroedinger equation must guarantee that

$$\frac{d}{dt} \int_{-\infty}^{\infty} dx |\psi(x,t)|^2 = 0.$$

This is, in fact, the case. By differentiating with respect to time under the integral and then using the Schroedinger equation, one can show that the vanishing of the time derivative requires

$$\left[\frac{d\psi^*(x, t)}{dx} \psi(x, t) - \psi^*(x, t) \frac{d\psi(x, t)}{dx} \right]_{x \rightarrow -\infty}^{x \rightarrow \infty} = 0.$$

This is usually satisfied by requiring $\psi(x, t)$ to vanish at the boundaries.

In most situations, the Schroedinger wave function must satisfy certain boundary conditions that are

1. $\psi(x,t)$ must be finite everywhere.
2. $\psi(x,t)$ must be single valued.
3. For finite potentials, $\psi(x,t)$ and $d\psi(x,t)/dx$ must be continuous.
4. $\psi(x,t)$ must vanish as $x \rightarrow \pm\infty$.

Time-Independent Schroedinger Equation

The original form of the Schroedinger equation is that of a partial differential equation in x and t . It can be solved by the method of separation of variables if V is time independent, which we will assume. Then, assuming

$$\psi(x, t) = u(x)f(t)$$

the partial derivatives become ordinary derivatives and the Schroedinger equation is

$$i\hbar \frac{1}{f(t)} \frac{df(t)}{dt} = -\frac{\hbar^2}{2m} \frac{1}{u(x)} \frac{d^2u(x)}{dx^2} + V(x).$$

Now, the left side depends only on t and the right side only on x . This can only be true if both sides equal a constant, say E . We then get two ordinary differential equations

$$-\frac{\hbar^2}{2m} \frac{d^2u(x)}{dx^2} + V(x)u(x) = Eu(x)$$
$$i\hbar \frac{df(t)}{dt} = Ef(t).$$

The last equation is first order and easily solved. The solution is

$$f(t) = e^{-iEt/\hbar}.$$

Solutions to the remaining second order differential equation must satisfy the boundary conditions. This is only possible for certain values of E . These E 's are the allowed energies of a quantum mechanical particle moving in the potential $V(x)$. They are called the eigenvalues of the differential operator

$$H = -\frac{\hbar^2}{2m} \frac{d^2}{dx^2} + V(x)$$

and the functions $u(x)$ are called the eigenfunctions of the system. The equation

$$Hu(x) = Eu(x)$$

is known as the time independent Schroedinger equation. H resembles the classical expression for the energy

$$E = \frac{p^2}{2m} + V(x)$$

if we make the (bold) identification

$$p = -i\hbar \frac{d}{dx}.$$

For a given eigenvalue E , the complete expression for $\psi(x,t)$ is

$$\psi(x,t) = u(x)e^{-iEt/\hbar}.$$

The normalization integral in this case is

$$\begin{aligned}\int_{-\infty}^{\infty} dx |\psi(x, t)|^2 &= \int_{-\infty}^{\infty} dx u^*(x) e^{iEt/\hbar} u(x) e^{-iEt/\hbar} \\ &= \int_{-\infty}^{\infty} dx |u(x)|^2 = 1.\end{aligned}$$

If there are several different eigenvalues E_n , each comes with an eigenfunction $u_n(x)$ that can be normalized in this way. The general solution is obtained by superposition and can be written as

$$\psi(x, t) = \sum_{n=1}^N a_n e^{-iE_n t/\hbar} u_n(x).$$

You may ask 'What guarantees that this way of determining the energy eigenvalues E_n always gives real values?' It turns out that if $V(x)$ is real and the boundary conditions are satisfied, then the eigenvalues of H are real.

It can also be shown that different eigenfunctions obey

$$\int_{-\infty}^{\infty} dx u_m^*(x) u_n(x) = 0 \quad m \neq n.$$

If the integral of any two different eigenfunctions vanishes, the functions are said to be orthogonal. Hence, the allowed energies of a quantum system obtained by solving the time-independent Schrodinger equation are real and their eigenfunctions are orthogonal.

In view of this, if we look back at the general $\psi(x,t)$ obtained by superposition,

$$\psi(x, t) = \sum_{n=1}^N a_n e^{-iE_n t/\hbar} u_n(x).$$

and calculate the normalization integral

$$\int_{-\infty}^{\infty} dx |\psi(x, t)|^2 = \int_{-\infty}^{\infty} dx \left(\sum_{m=1}^N a_m e^{-iE_m t/\hbar} u_m(x) \right)^* \times \left(\sum_{n=1}^N a_n e^{-iE_n t/\hbar} u_n(x) \right)$$

we find that the cross terms vanish and

$$\int_{-\infty}^{\infty} dx |\psi(x, t)|^2 = \sum_{n=1}^N |a_n|^2 = 1.$$

Notice that a_n is the amplitude of the n^{th} eigenfunction $u_n(x)$ in the expansion and the sum of the $|a_n|^2$ adds up to 1. This allows a probability interpretation of the $|a_n|^2$ that we will exploit later.

Time-Dependent Schroedinger Equation



1. $|\psi(x,t)|^2 dx$
2. Normalization
3. Boundary cond.



Separation of variables



$$f(t) = e^{-iEt/\hbar}$$



$$Hu_n(x) = E_n u_n(x)$$



$$\int dx |u_n(x)|^2 = 1$$
$$\int dx u_m^*(x) u_n(x) = 0$$

for $m \neq n$

$$\psi(x,t) = \sum_{n=1}^N a_n e^{-iE_n t/\hbar} u_n(x)$$



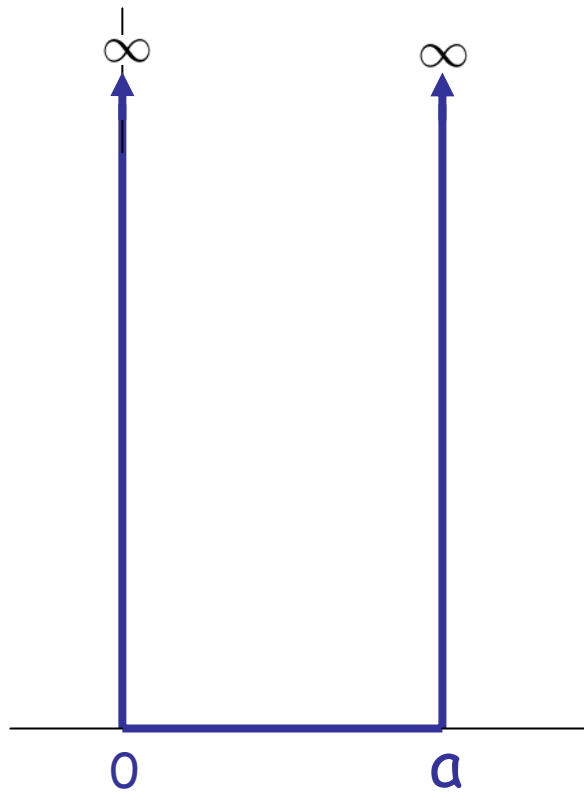

Infinite Potential Well

$$V(x) = \begin{cases} 0 & \text{for } 0 \leq x \leq a \\ \infty & \text{for } x < 0 \text{ or } x > a \end{cases}$$

For this simple potential, the time-independent Schroedinger equation is

$$\frac{d^2 u(x)}{dx^2} = -\frac{2mE}{\hbar^2} u(x) = -k^2 u(x).$$

$$k = \sqrt{\frac{2mE}{\hbar^2}}$$

For this potential, the particle cannot be outside the well, so $u(0)=0$ and $u(a)=0$. The solution to the Schroedinger equation is

$$u(x) = A \sin(kx) + B \cos(kx).$$

Applying the boundary condition at $x=0$,

$$0 = A \sin(0) + B \cos(0) = B,$$

so B must vanish. This leaves the $A \sin(kx)$ term and if $u(a)$ is to equal zero, then

$$0 = A \sin(ka).$$

We can't set $A=0$ because this makes $u(x)=0$. We can, however, use the fact that $\sin(n\pi)=0$ to conclude that the time-independent Schroedinger equation has non-trivial solutions if $ka=n\pi$. There are infinitely many solutions

$$A_n \sin\left(\frac{n\pi x}{a}\right).$$

Each of these solutions, or eigenfunctions, is associated with a unique energy level or eigenvalue. The energies are

$$E_n = \frac{\hbar^2 k^2}{2m} = \frac{n^2 \pi^2 \hbar^2}{2ma^2} = n^2 E_1.$$

The normalization integral is

$$1 = |A_n|^2 \int_0^a dx \sin^2 \left(\frac{n\pi x}{a} \right) = \frac{a}{2} |A_n|^2.$$

The normalized eigenfunctions are

$$u_n(x) = \sqrt{\frac{2}{a}} \sin\left(\frac{n\pi x}{a}\right).$$

You can check that the orthogonality relation

$$\int_0^a dx u_m^*(x) u_n(x) = 0 \quad m \neq n$$

is satisfied for these eigenfunctions.

The first four eigenfunctions are shown below.

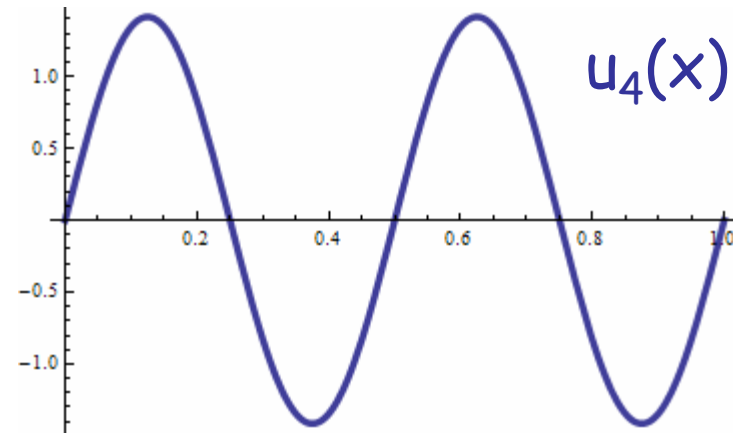
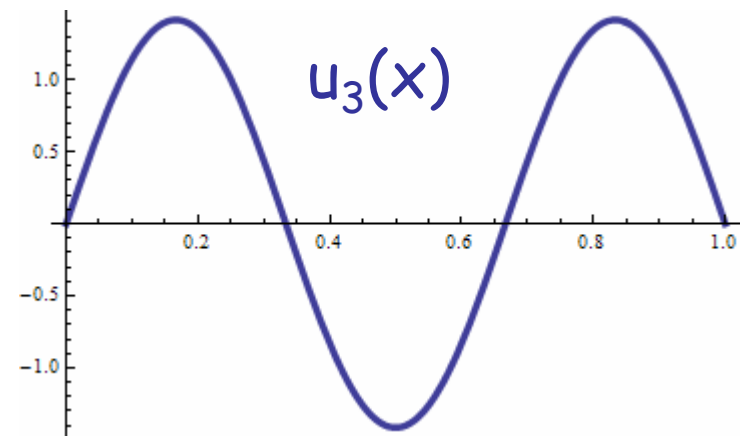
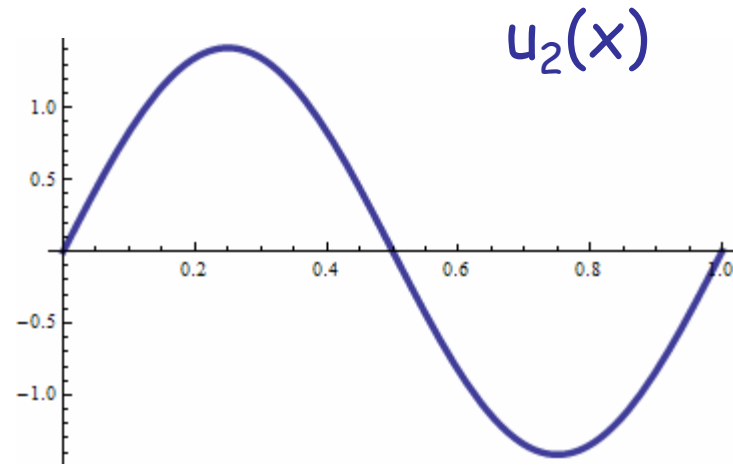
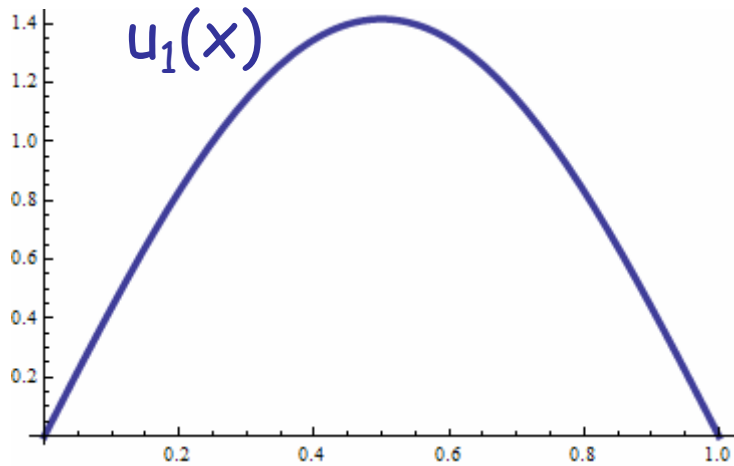

$u_1(x)$ is called the ground state wavefunction and the remaining eigenfunctions are called excited state wavefunctions. All of the energy eigenfunctions are real.

With the exception of the ground state, all eigenfunctions take on negative values and cannot be interpreted as probability distributions. This illustrates why it is necessary to use $|\psi(x,t)|^2$ as the probability distribution for the position.

The probability distributions are

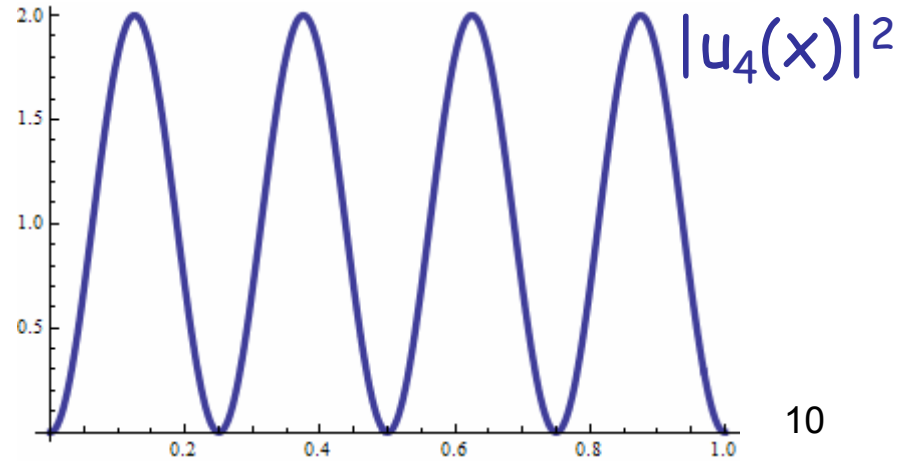
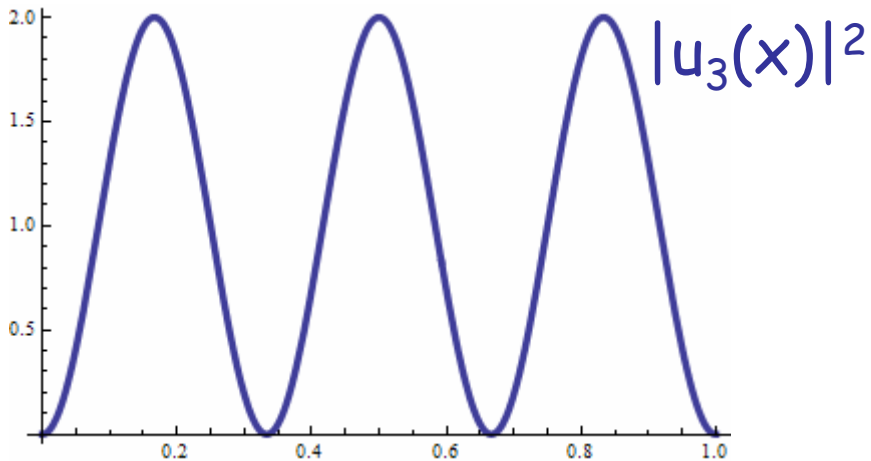
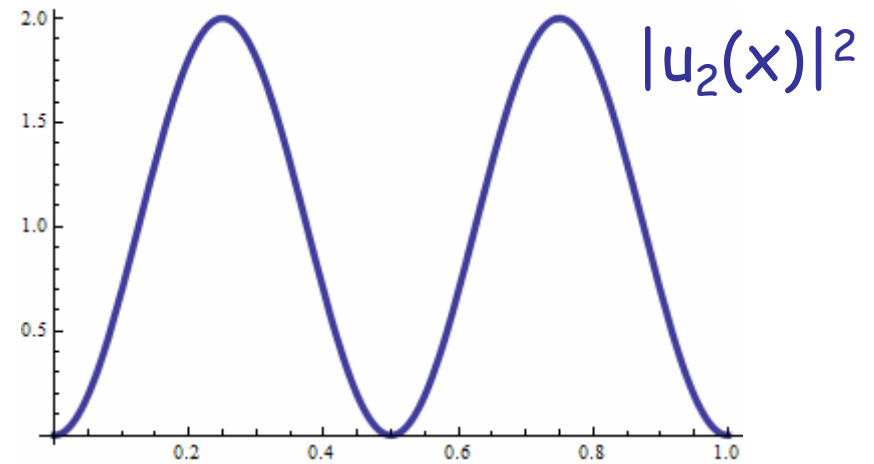
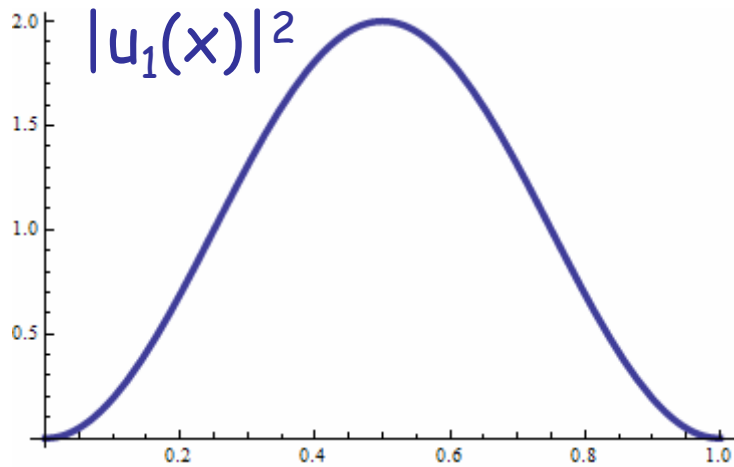

Returning to the eigenfunctions, note that

as n increases the number of times the graph passes through zero

increases. Not counting the end points, $n=1$ has no crossings, $n=2$ one

crossing, $n=3$, two crossings, etc. These crossings are called nodes and the n^{th} excited state has n nodes.

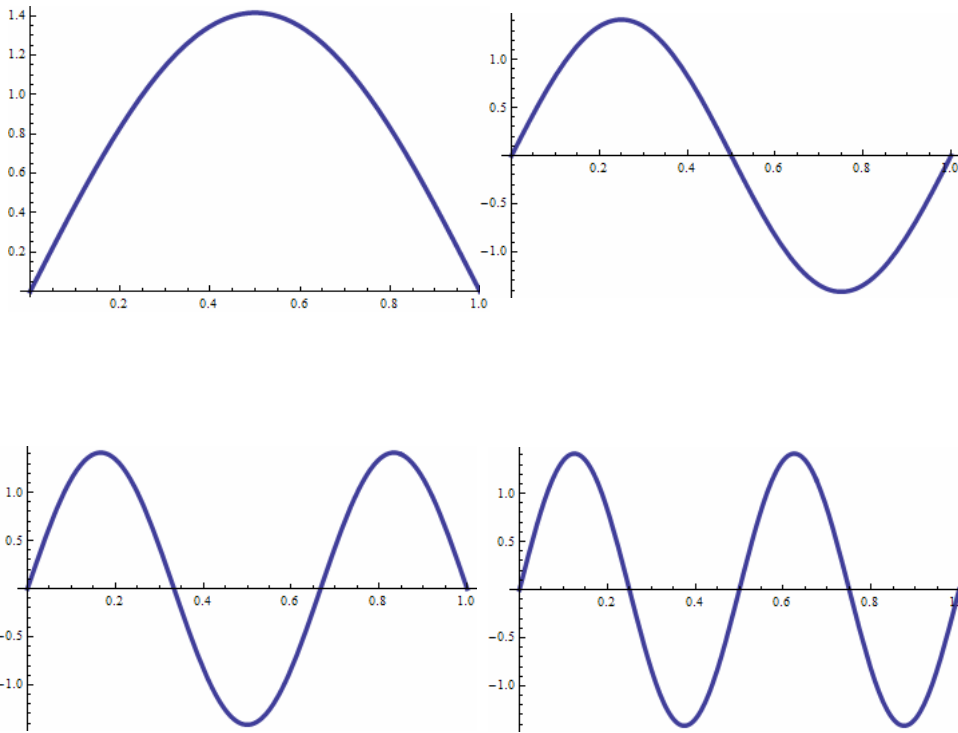

Suppose we now use superposition to construct a solution to the time-dependent Schroedinger equation. As a simple example, consider

$$\psi(x, t) = \left(\frac{1}{2}\right) e^{-iE_1 t/\hbar} \sqrt{2} \sin(\pi x) - \left(\frac{\sqrt{3}}{2}\right) e^{-i4E_1 t/\hbar} \sqrt{2} \sin(2\pi x).$$

The wave function is properly normalized since

$$\left(\frac{1}{2}\right)^2 + \left(\frac{-\sqrt{3}}{2}\right)^2 = 1.$$

At $t = 0$, a plot of the wavefunction is

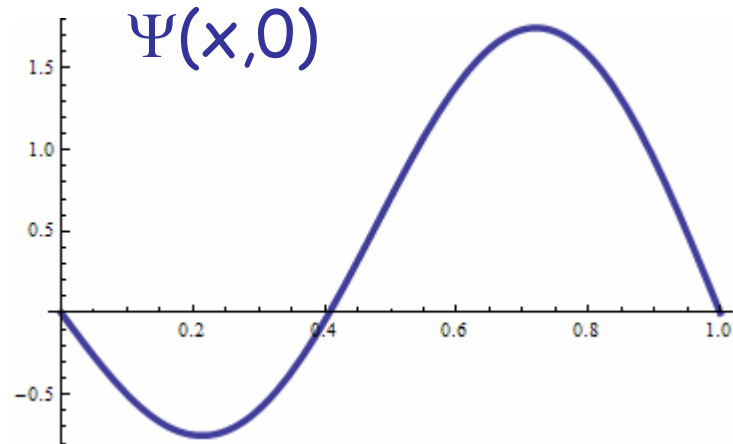

and the probability density at $t = 0$ is

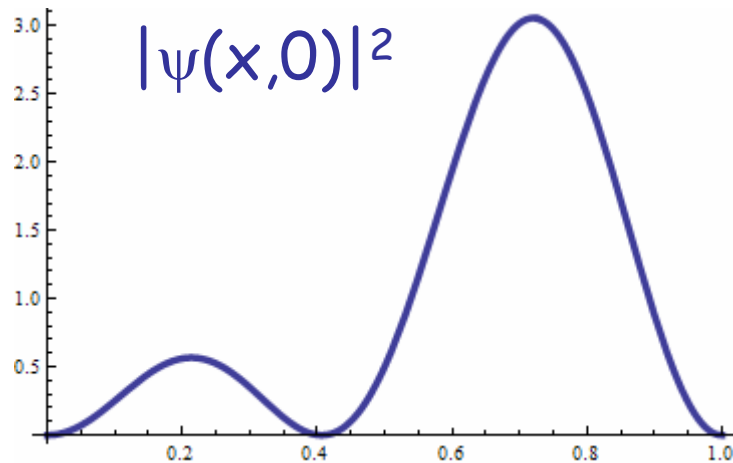

In quantum theory, the interpretation of a wave function like

$$\psi(x, t) = \frac{1}{2}e^{-iE_1t/\hbar}\sqrt{2}\sin(\pi x) - \frac{\sqrt{3}}{2}e^{-i4E_1t/\hbar}\sqrt{2}\sin(2\pi x).$$

is this: If the energy of a particle with this wave function is measured, only two results can be obtained, E_1 and $4E_1$. The probability of measuring E_1 is

$$P(E_1) = \left(\frac{1}{2}\right)^2 = \frac{1}{4},$$

and of measuring $4E_1$ is

$$P(4E_1) = \left(-\frac{\sqrt{3}}{2}\right)^2 = \frac{3}{4}.$$

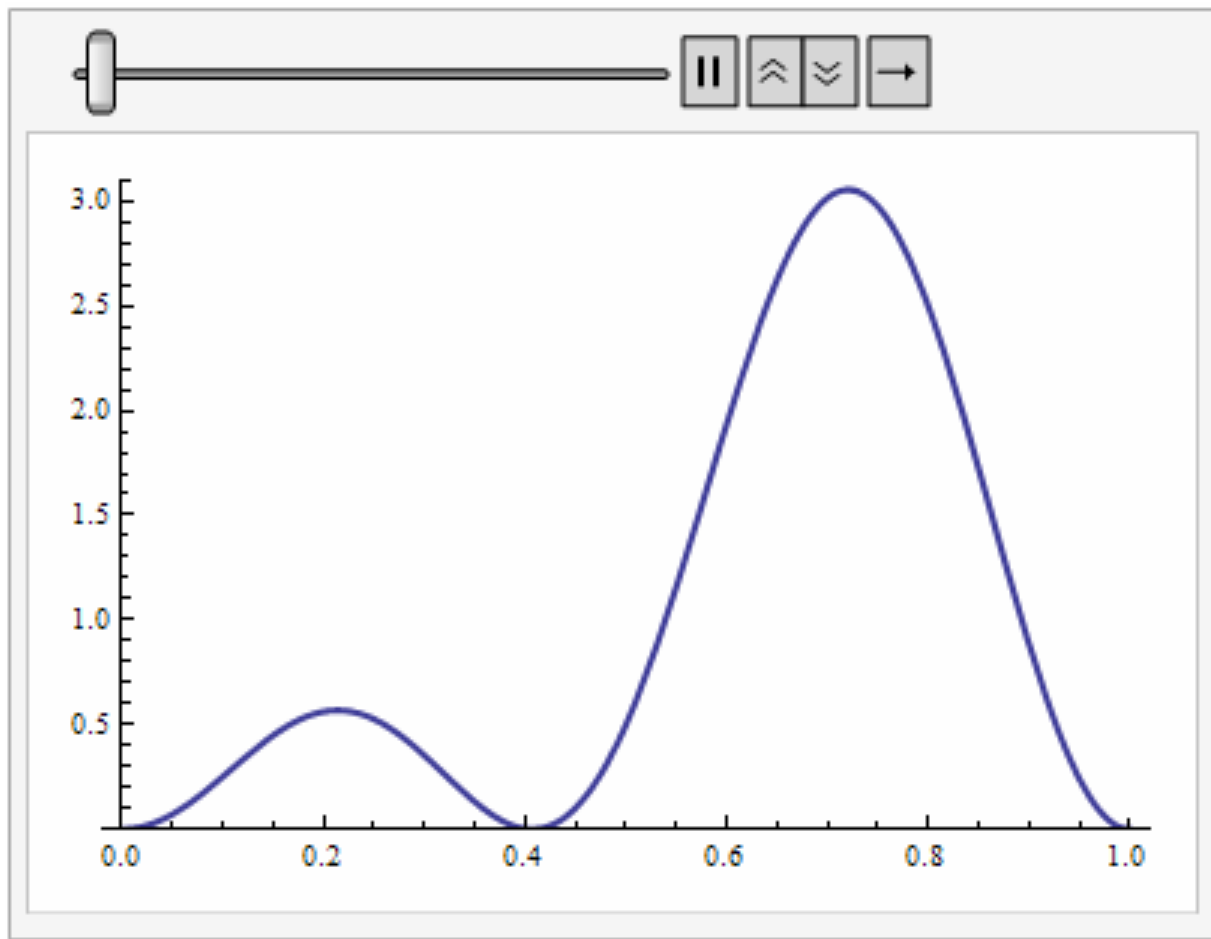

Recalling our example of $\psi(x,t)$,

$$\psi(x, t) = \frac{1}{2}e^{-iE_1t/\hbar}\sqrt{2}\sin(\pi x) - \frac{\sqrt{3}}{2}e^{-i4E_1t/\hbar}\sqrt{2}\sin(2\pi x),$$

we could imagine making a slight change in the coefficients

$$\psi(x, t) = \frac{i}{2}e^{-iE_1t/\hbar}\sqrt{2}\sin(\pi x) - \frac{\sqrt{3}}{2}e^{-i4E_1t/\hbar}\sqrt{2}\sin(2\pi x).$$

Here, too, a measurement of E will yield only E_1 and $4E_1$ with the same probabilities, since

$$\left|\frac{i}{2}\right|^2 = \frac{1}{4}.$$

In this case, the probability distribution at $t = 0$ is

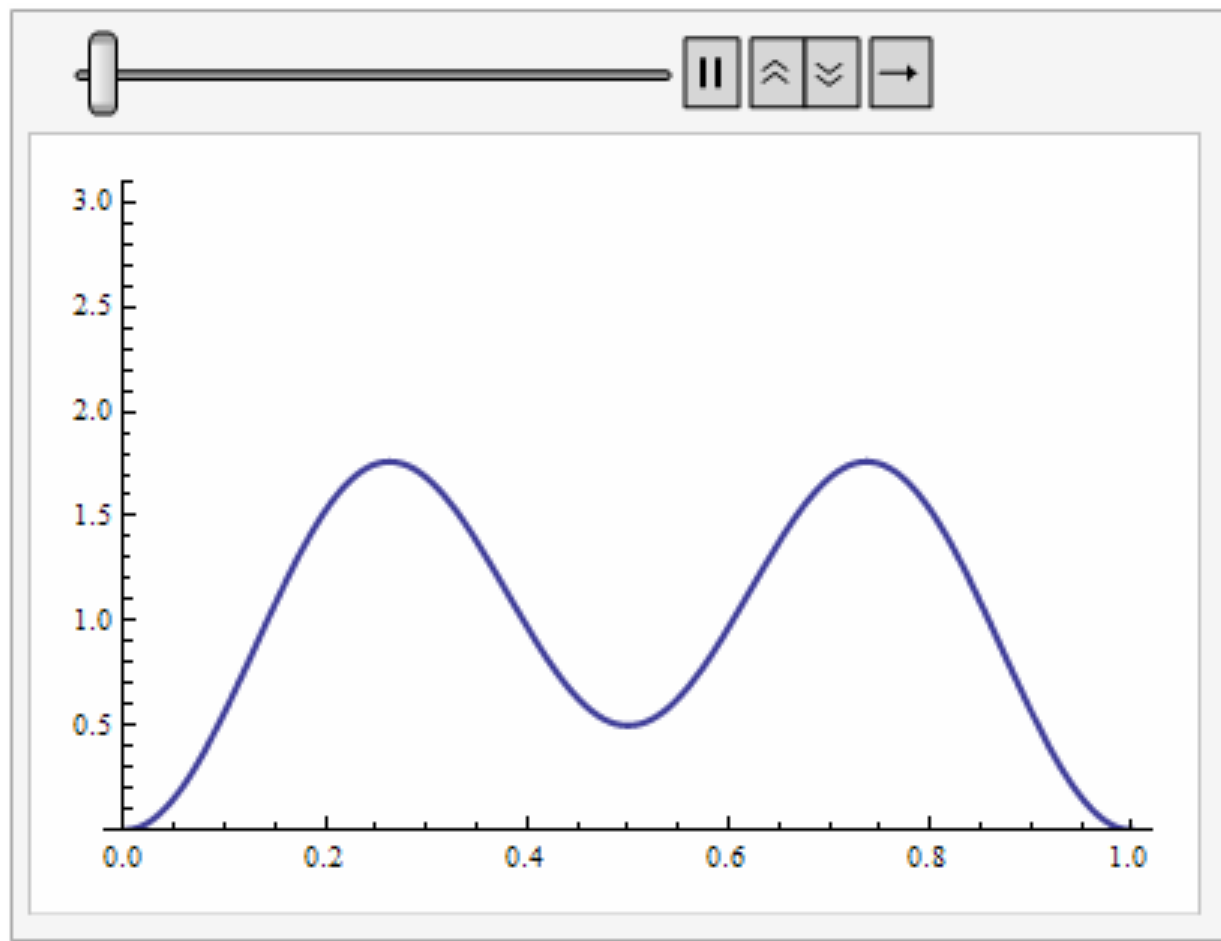

This change amounts to a resetting of the initial time, as can be seen from the previous case

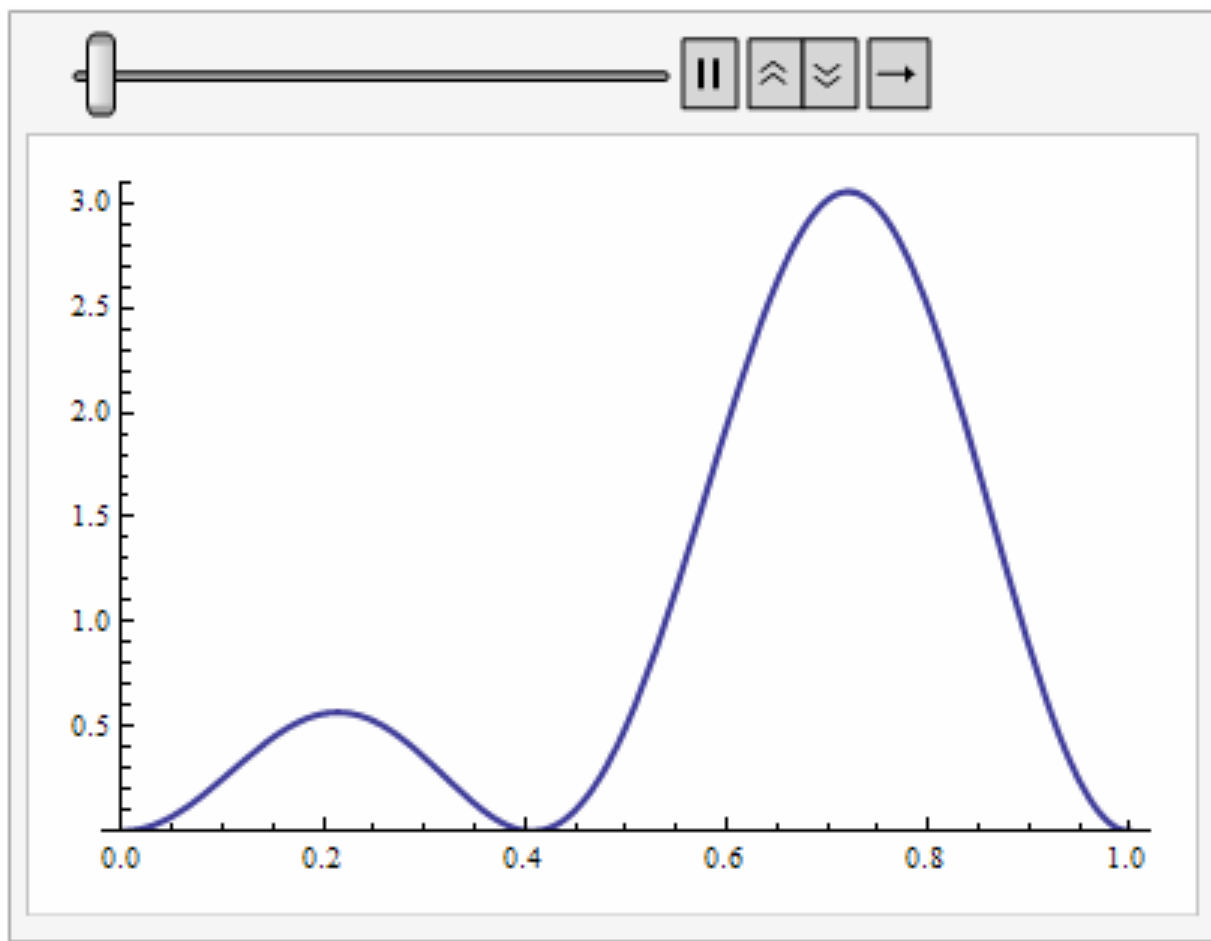

Now, suppose that you know the (normalized) wave function of a particle moving in an infinite well at $t = 0$ and you would like to know what energies you might measure and with what probability. You can expand $\psi(x,0)$ in terms of the energy eigenfunctions as

$$\psi(x, 0) = \sum_{m=1}^{\infty} a_m u_m(x).$$

Since the $u_n(x)$ are orthogonal and normalized (orthonormal), the a_n 's are

$$\int_0^a dx u_n(x) \psi(x, 0) = \sum_{m=1}^{\infty} a_m \int_0^a dx u_n(x) u_m(x) = a_n.$$

According to the rules of quantum mechanics, if a_n is non-zero, then E_n will be measured with probability $|a_n|^2$. Further, for $t > 0$

$$\psi(x, t) = \sum_{n=1}^{\infty} a_n e^{-in^2 E_1 t / \hbar} u_n(x).$$

As an example, suppose $\psi(x, 0)$ is

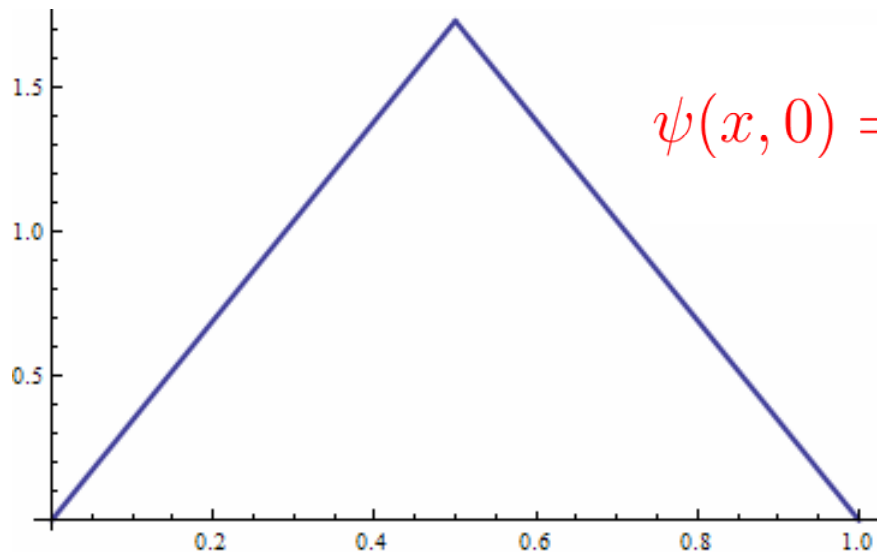

$$\psi(x, 0) = \begin{cases} \sqrt{12}x & \text{for } 0 < x < 0.5 \\ \sqrt{12}(1-x) & \text{for } 0.5 < x < 1 \end{cases}$$

Carrying out this process yields

$$\psi(x, t) = \sum_{k=1}^{\infty} \frac{8\sqrt{3}}{\sqrt{2}(2k-1)^2\pi^2} e^{-i(2k-1)^2 E_1 t/\hbar} \sqrt{2} \sin((2k-1)\pi x).$$

From this, we see that only the odd squared multiples of E_1 occur, so a measurement of the energy would never result in $4 E_1$. The squared coefficients are

$$|a_{2k-1}|^2 = \frac{96}{(2k-1)^4\pi^4},$$

which, when summed, add up to 1.

How well does the summation describe $\psi(x,0)$?

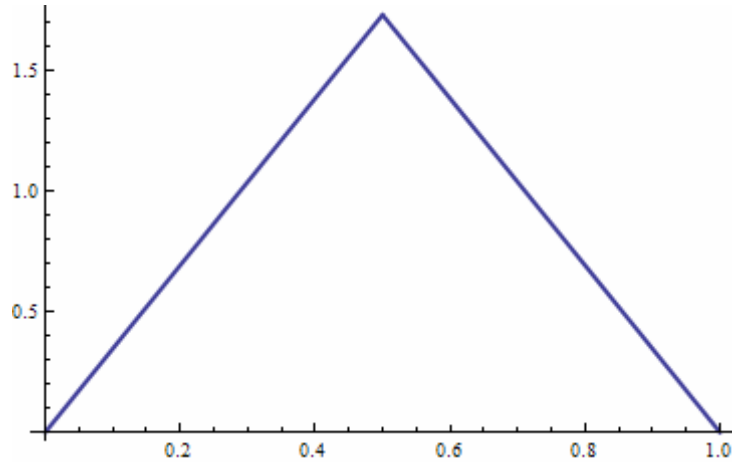

$|\psi(x,0)|^2$?

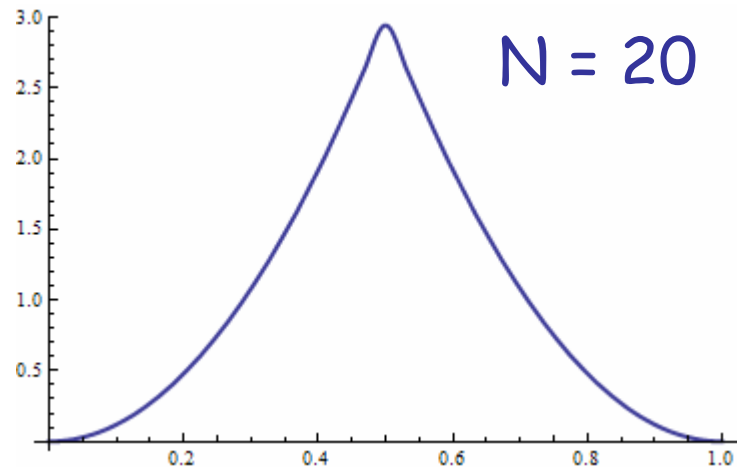
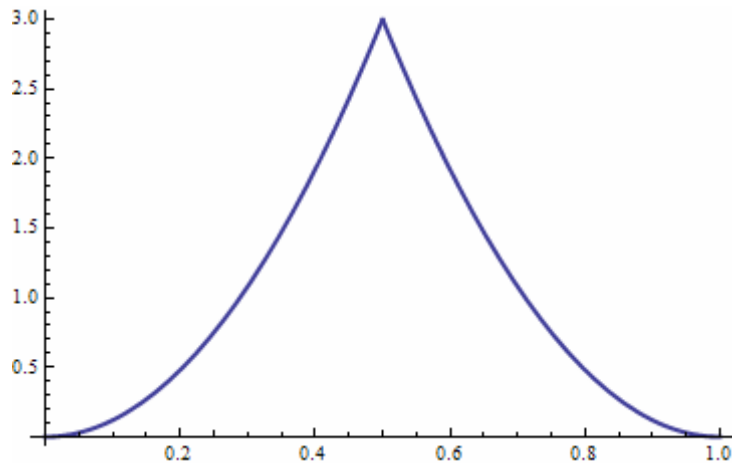

The probability density $|\psi(x,t)|^2$ evolves in time as

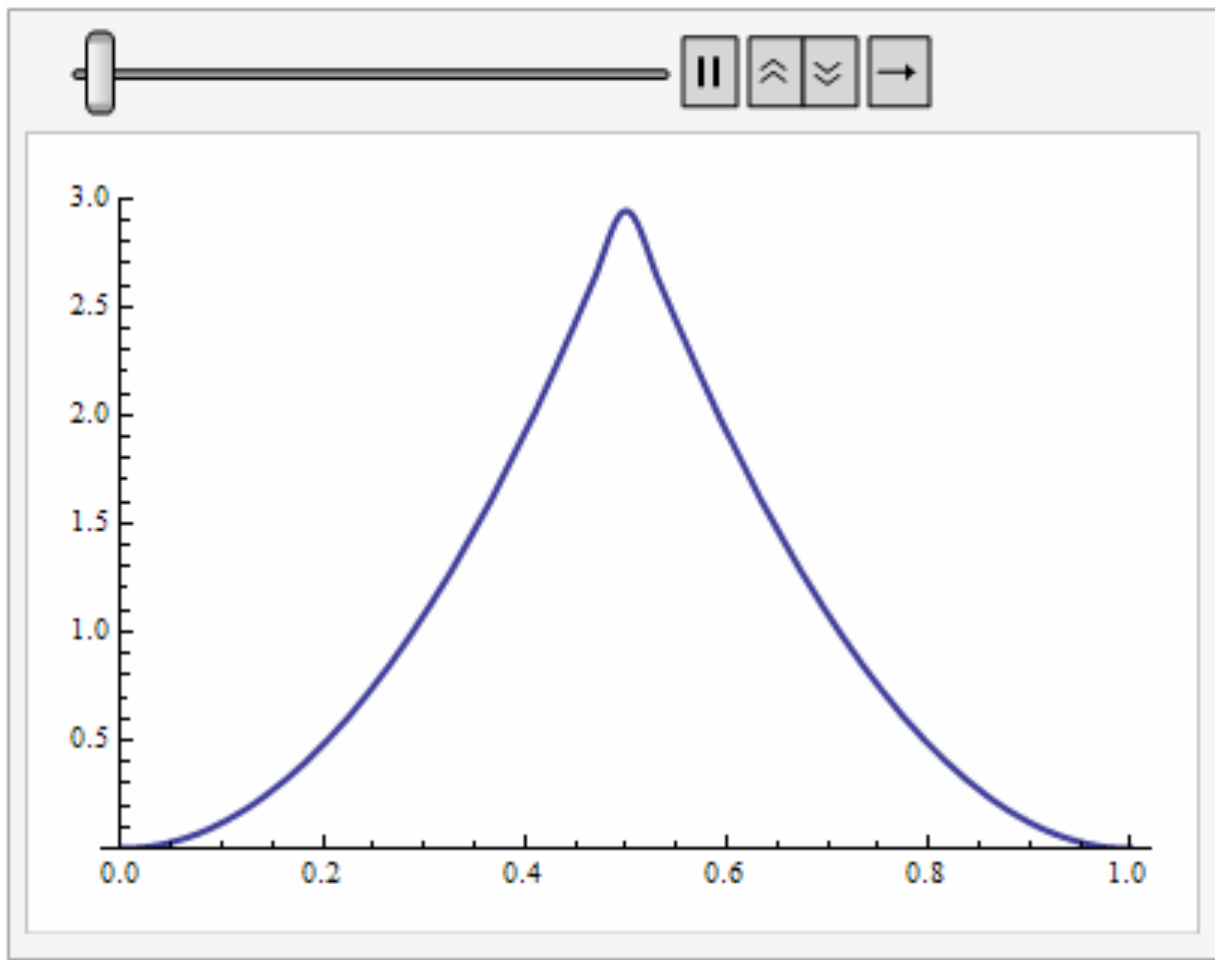

Expectation Values and Averages

We have acknowledged that $|\psi(x,t)|^2 dx$ is the probability that x is in the interval between x and $x+dx$. From probability theory, the average value or expectation value of x , $\langle x \rangle$ is

$$\langle x \rangle = \int_{-\infty}^{\infty} dx x |\psi(x, t)|^2 .$$

This can also be written

$$\langle x \rangle = \int_{-\infty}^{\infty} dx \psi^*(x, t) x \psi(x, t) .$$

For any physical observable Q , its average value or expectation value $\langle Q \rangle$, can be calculated as

$$\langle Q \rangle = \int_{-\infty}^{\infty} dx \psi^*(x,t) \hat{Q} \psi(x,t)$$

where \hat{Q} is its corresponding operator,

For example:

$$\begin{aligned} \langle Q \rangle &\longrightarrow \hat{Q} \\ x: &\hat{x} = x \\ p: &\hat{p} = -i\hbar \frac{d}{dx} \\ E: &\hat{H} \end{aligned}$$

eigenfunction

eigenvalue

$$\left(\text{for } \hat{H} u_n(x) = E_n u_n(x) \right)$$

This form is convenient because we might also want to compute the average value of H or p , both of which involve derivatives with respect to x as well as functions of x :

$$H = -\frac{\hbar^2}{2m} \frac{d^2}{dx^2} + V(x) \quad p = -i\hbar \frac{d}{dx}.$$

We can then write

$$\langle H \rangle = \int_{-\infty}^{\infty} dx \psi^*(x, t) H \psi(x, t)$$

$$\langle p \rangle = \int_{-\infty}^{\infty} dx \psi^*(x, t) \left(-i\hbar \frac{d}{dx} \right) \psi(x, t).$$

As an example, what is the average value of x for an eigenstate of a particle in an infinite well?

$$\begin{aligned}\langle x \rangle_n &= \frac{2}{a} \int_0^a dx x \sin^2 \left(\frac{n\pi x}{a} \right) = \frac{a}{n^2 \pi^2} \int_0^{n\pi} dt t (1 - \cos(2t)) \\ \langle x \rangle_n &= \frac{a}{n^2 \pi^2} \left[\frac{t^2}{2} - \frac{t}{2} \sin(2t) - \frac{1}{4} \cos(2t) \right]_0^{n\pi} = \frac{a}{2}\end{aligned}$$

The result for $\langle x^2 \rangle$ can be calculated similarly.

$$\begin{aligned}\langle x^2 \rangle_n &= \frac{2}{a} \int_0^a dx x^2 \sin^2 \left(\frac{n\pi x}{a} \right) = \frac{a^2}{n^3 \pi^3} \int_0^{n\pi} dt t^2 (1 - \cos(2t)) \\ \langle x^2 \rangle_n &= \frac{a^2}{3} \left(1 - \frac{3}{2n^2 \pi^2} \right).\end{aligned}$$

The expectation value of p is

$$\begin{aligned}\langle p \rangle_n &= \frac{2}{a} \int_0^a dx \sin\left(\frac{n\pi x}{a}\right) \left(-i\hbar \frac{d}{dx}\right) \sin\left(\frac{n\pi x}{a}\right) \\ &= -i\hbar \frac{2n\pi}{a^2} \int_0^a dx \sin\left(\frac{n\pi x}{a}\right) \cos\left(\frac{n\pi x}{a}\right) \\ \langle p \rangle_n &= -i \frac{\hbar}{a} \sin^2\left(\frac{n\pi x}{a}\right) \Big|_0^a = 0.\end{aligned}$$

For $\langle p^2 \rangle$,

$$\begin{aligned}\langle p^2 \rangle_n &= \frac{2}{a} \int_0^a dx \sin\left(\frac{n\pi x}{a}\right) \left(-i\hbar \frac{d}{dx}\right)^2 \sin\left(\frac{n\pi x}{a}\right) \\ \langle p^2 \rangle_n &= \frac{2n^2\pi^2\hbar^2}{a^3} \int_0^a dx \sin^2\left(\frac{n\pi x}{a}\right) = \frac{n^2\pi^2\hbar^2}{a^2}.\end{aligned}$$

These calculations provide a general definition for the uncertainties Δx and Δp . They are defined to be

$$\Delta x = \sqrt{\langle x^2 \rangle - \langle x \rangle^2}$$

$$\Delta p = \sqrt{\langle p^2 \rangle - \langle p \rangle^2}.$$

For the particle in an infinite well, $\Delta x_n \Delta p_n$ is

$$\Delta x_n \Delta p_n = n\pi \sqrt{\frac{1}{12} - \frac{1}{2n^2\pi^2}} \hbar > \frac{\hbar}{2}.$$

The expectation value of H in an eigenstate is simple enough, since

$$\int_{-\infty}^{\infty} dx u_n^*(x) H u_n(x) = E_n \int_{-\infty}^{\infty} dx u_n^*(x) u_n(x) = E_n.$$

This simple result enables us to calculate $\langle H \rangle$ for the time dependent case

$$\psi(x, t) = \sum_{n=1}^{\infty} a_n e^{-iE_n t/\hbar} u_n(x).$$

Using orthogonality, the result is

$$\langle H \rangle = \sum_{n=1}^{\infty} E_n |a_n|^2.$$

This confirms the interpretation of the a_n 's as probability amplitudes whose absolute squares determine the probability that the energy E_n will be measured.

Infinite potential well in 3D

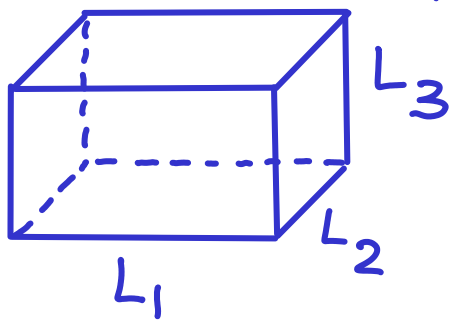

The three coordinates x , y and z are independent.

$$\Psi(x, y, z) = A \cdot \sin(k_1 x) \cdot \sin(k_2 y) \cdot \sin(k_3 z)$$

$$k_1 = \frac{n_1 \pi}{L_1} \quad ; \quad k_2 = \frac{n_2 \pi}{L_2} \quad ; \quad k_3 = \frac{n_3 \pi}{L_3}$$

$n_1, n_2, n_3 = 1, 2, 3, \dots$ independently

$$E_{n_1, n_2, n_3} = \frac{h^2}{8m} \left(\frac{n_1^2}{L_1^2} + \frac{n_2^2}{L_2^2} + \frac{n_3^2}{L_3^2} \right)$$

Cubical box : $L_1 = L_2 = L_3 = L$

$$E_{n_1, n_2, n_3} = \frac{h^2}{8mL^2} (n_1^2 + n_2^2 + n_3^2)$$

Ground state: $E_{gs} = \frac{3h^2}{8mL^2}$

1st excited state: $E_{1st \text{ xs}} = \frac{6h^2}{8mL^2}$

Degeneracy: several different states

have the same energy: $(2, 1, 1)$;
 $(1, 2, 1)$; $(1, 1, 2)$.

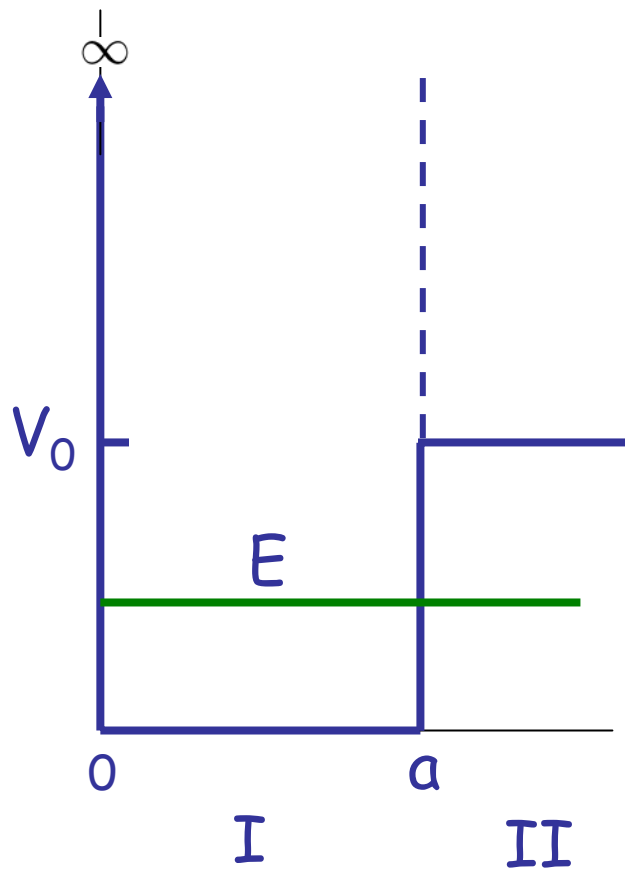

The infinite square well illustrates many aspects of quantum mechanics. However, when the potential is finite there are other surprises.

By lowering the infinite barrier on the right to V_0 , we now have two regions, I and II with different values of the potential.

$$V = \begin{cases} 0 & \text{if } 0 < x < a \\ V_0 & \text{if } x > a \end{cases}$$

For $E < V_0$, the Schrodinger equations for regions I and II are

$$-\frac{\hbar^2}{2m} \frac{d^2 u_I(x)}{dx^2} = E u_I(x), \quad -\frac{\hbar^2}{2m} \frac{d^2 u_{II}(x)}{dx^2} + V_0 u_{II}(x) = E u_{II}(x).$$

These can be rewritten as

$$\frac{d^2 u_I(x)}{dx^2} + k^2 u_I(x) = 0, \quad k = \sqrt{2mE/\hbar^2}$$
$$\frac{d^2 u_{II}(x)}{dx^2} - \kappa^2 u_{II}(x) = 0, \quad \kappa = \sqrt{2m(V_0 - E)/\hbar^2}.$$

(For $V_0 > E$)

The solutions to these equations are

$$u_I(x) = A_I \sin(kx) + B_I \cos(kx),$$
$$u_{II}(x) = A_{II} e^{-\kappa x} + B_{II} e^{\kappa x}.$$

Imposing the boundary conditions gives

$$u_I(0) = A_I 0 + B_I = 0,$$

$$u_{II}(x \rightarrow \infty) = A_{II} 0 + B_{II} \lim_{x \rightarrow \infty} e^{\kappa x} = 0.$$

This means that both B_I and B_{II} must vanish. Then,

$$u_I(x) = A_I \sin(kx), \quad u_{II}(x) = A_{II} e^{-\kappa x}.$$

At $x = a$, V is finite and hence the wave function and its first derivative must be continuous at this point. Hence,

$$A_I \sin(ka) = A_{II} e^{-\kappa a}$$

$$kA_I \cos(ka) = -\kappa A_{II} e^{-\kappa a}.$$

It's perhaps clearer if we write this as

$$\sin(ka)A_I - e^{-\kappa a}A_{II} = 0$$

$$k \cos(ka)A_I + \kappa e^{-\kappa a}A_{II} = 0.$$

If this pair of homogeneous equations for A_I and A_{II} is to have a non-trivial solution, the determinant of the coefficients must vanish:

$$\kappa \sin(ka)e^{-\kappa a} + k \cos(ka)e^{-\kappa a} = 0,$$

or

$$\underline{ka \cot(ka)} = -\kappa a = \underline{-\sqrt{A^2 - k^2 a^2}} \quad A^2 = \frac{2ma^2 V_0}{\hbar^2}.$$

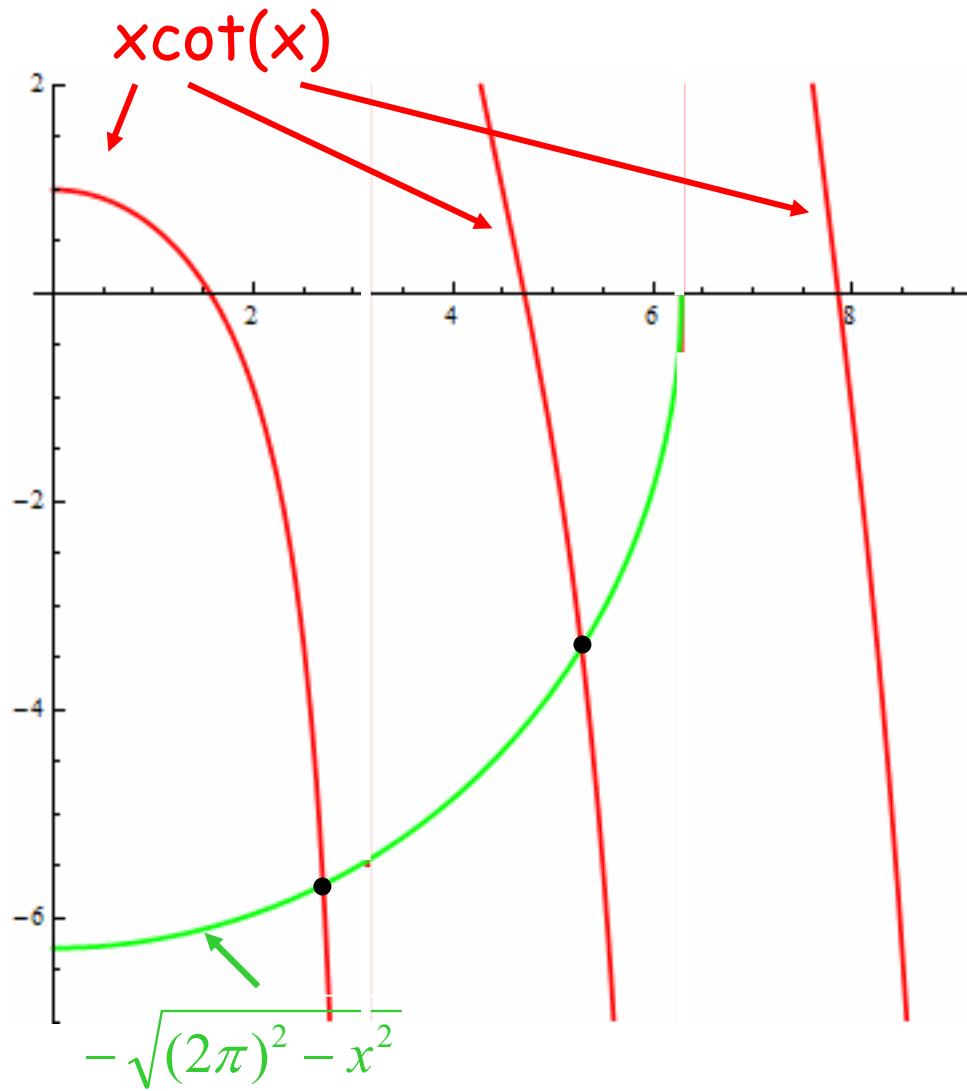

The underlined terms are a transcendental equation that determines k , and thus E .

The solutions can be obtained by graphing both sides and finding where they cross.

For $a=1$ and $A=2\pi$,

$$\begin{array}{l}
 k_1 = 2.698 \quad \kappa_1 = 5.675 \\
 k_2 = 5.284 \quad \kappa_2 = 3.300
 \end{array}
 \quad
 E_1 = \frac{7.279 \hbar^2}{2ma^2} \quad
 E_2 = \frac{31.18 \hbar^2}{2ma^2}$$

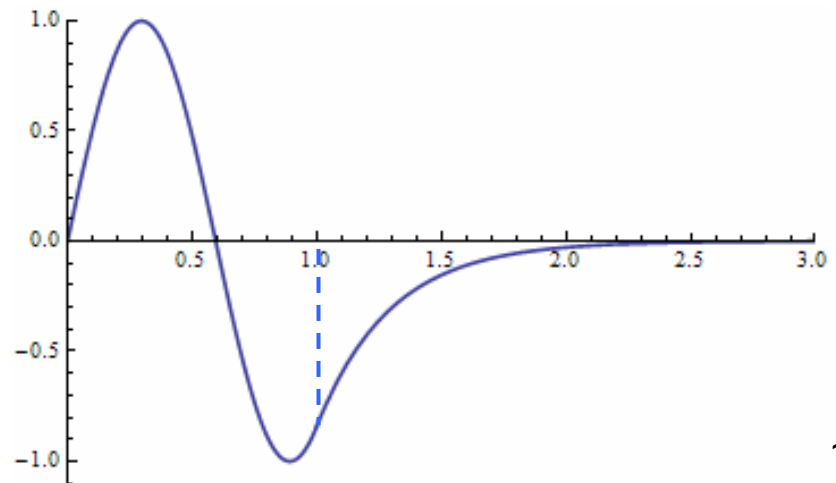
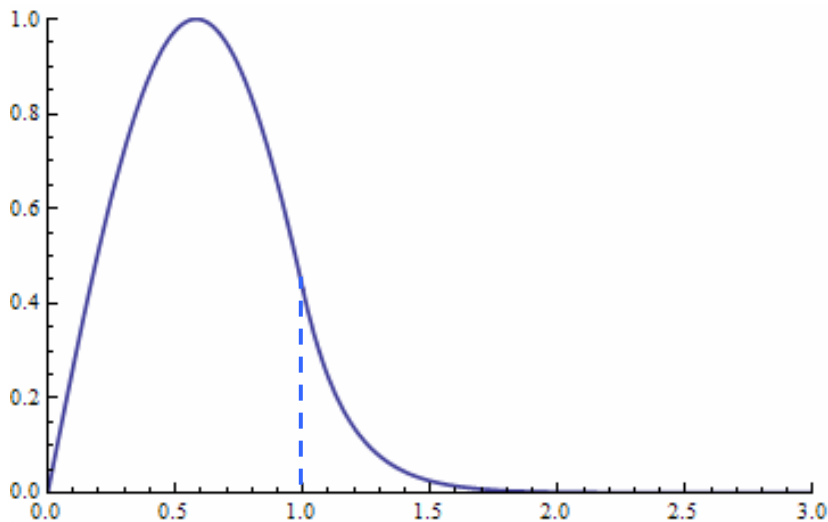

Harmonic Oscillator

For many smooth potentials we often can often expand about a minimum and look for motion near that minimum,

$$V(x) = V(x_0) + \frac{1}{2}V''(x_0)(x - x_0)^2.$$

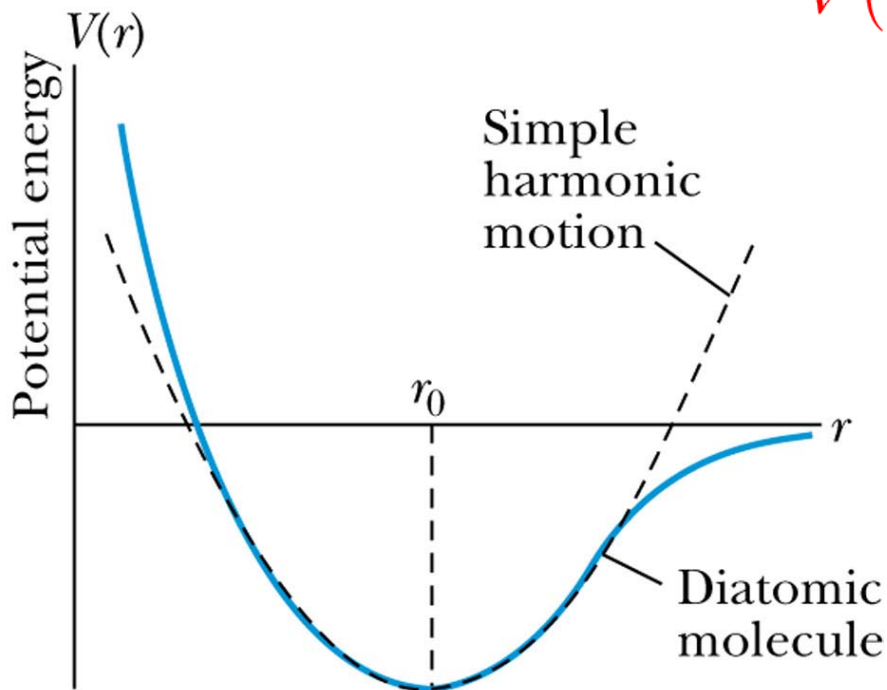

If $V''(x_0) > 0$, the motion is simple harmonic, so the quantum mechanical treatment of this potential is important.

If we take $V(x)$ to be

$$V(x) = \frac{1}{2}kx^2 = \frac{1}{2}m\omega^2x^2,$$

where we have used the classical relation between the k and the angular frequency ω , the Schrodinger equation is

$$-\frac{\hbar^2}{2m} \frac{d^2u(x)}{dx^2} + \frac{1}{2}m\omega^2x^2u(x) = Eu(x).$$

How do we go about solving this equation?

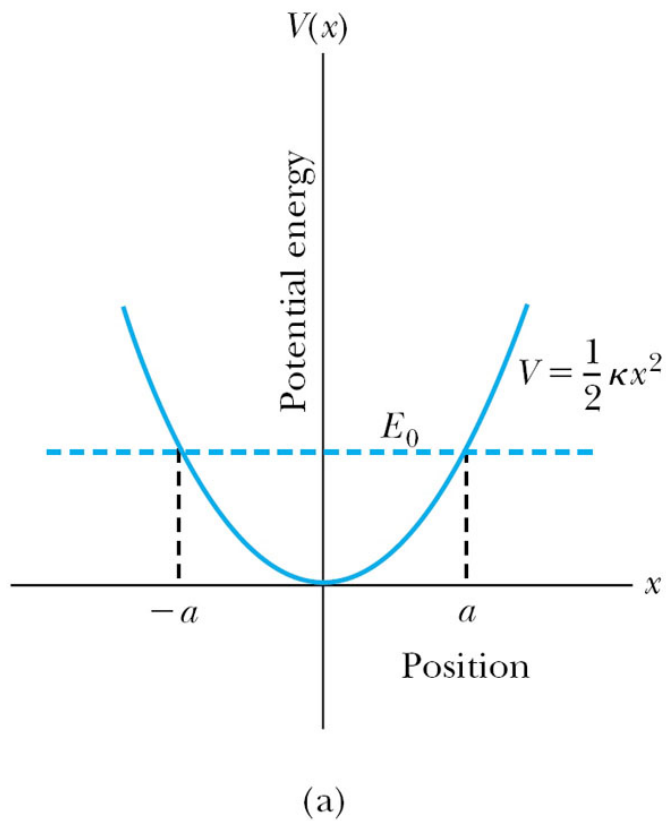

© 2006 Brooks/Cole - Thomson

The potential is symmetric about the origin and the ground state has no nodes. Its wave function should be symmetric and vanish as

$$u(x) \rightarrow 0 \quad \text{when} \quad x \rightarrow \pm\infty.$$

An inspired guess is

$$u(x) = Ae^{-\lambda x^2}.$$

Using

$$\frac{d^2}{dx^2} e^{-\lambda x^2} = (4\lambda^2 x^2 - 2\lambda) e^{-\lambda x^2}$$

the differential equation reads

$$\cancel{A} \left[-\frac{\hbar^2}{2m} (4\lambda^2 x^2 - 2\lambda) \cancel{e^{-\lambda x^2}} + \frac{1}{2} m\omega^2 x^2 \cancel{e^{-\lambda x^2}} \right] = E \cancel{A} \cancel{e^{-\lambda x^2}}.$$

For this to work,

$$\left(\frac{1}{2} m\omega^2 - \frac{2\lambda^2 \hbar^2}{m} \right) x^2 + \frac{\lambda \hbar^2}{m} = E.$$

Choosing λ to eliminate x^2 gives

$$\lambda = \frac{m\omega}{2\hbar}.$$

With this λ , E is then

$$E_0 = \frac{1}{2}\hbar\omega.$$

The ground state wave function is

$$u_0(x) = Ae^{-m\omega x^2/2\hbar},$$

and the normalization integral is

$$|A|^2 \int_{-\infty}^{\infty} dx e^{-m\omega x^2/\hbar} = |A|^2 \sqrt{\frac{\hbar}{m\omega}} \int_{-\infty}^{\infty} du e^{-u^2} = |A|^2 \sqrt{\frac{\pi\hbar}{m\omega}} = 1.$$

The normalized ground state wave function is

$$u_0(x) = \left(\frac{m\omega}{\pi\hbar} \right)^{1/4} e^{-m\omega x^2 / 2\hbar}.$$

What about excited states? We know that the first excited state has one node, the second two nodes, etc. This can be accomplished by multiplying $u_0(x)$ by a polynomial in x ,

$$u_n(x) = H_n(x)u_0(x),$$

where $H_n(x)$ has n zeros.

These polynomials can be found and are proportional to the Hermite polynomials. This determines the energies of the excited states as

$$E_n = \left(n + \frac{1}{2} \right) \hbar\omega,$$

and ensures that the eigenstates are orthogonal

$$\int_{-\infty}^{\infty} dx u_m(x) u_n(x) = 0 \quad m \neq n.$$

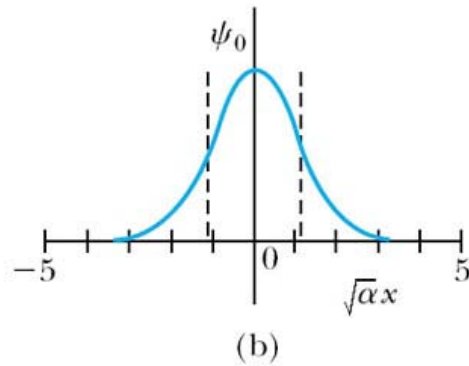
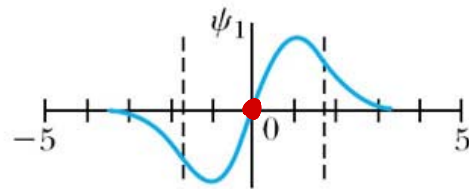
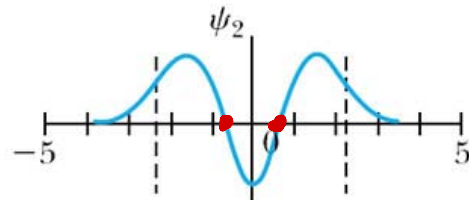
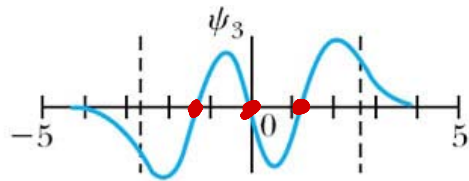

The first four wave functions are shown at the left.

Second excited state

$$E_2 = \left(2 + \frac{1}{2}\right) \hbar \omega$$

(with 2 nodes)

first excited state

$$E_1 = \left(1 + \frac{1}{2}\right) \hbar \omega$$

(with 1 node)

ground state $n=0$

$$E_0 = \frac{1}{2} \hbar \omega$$

(without node)

(zero-point energy)

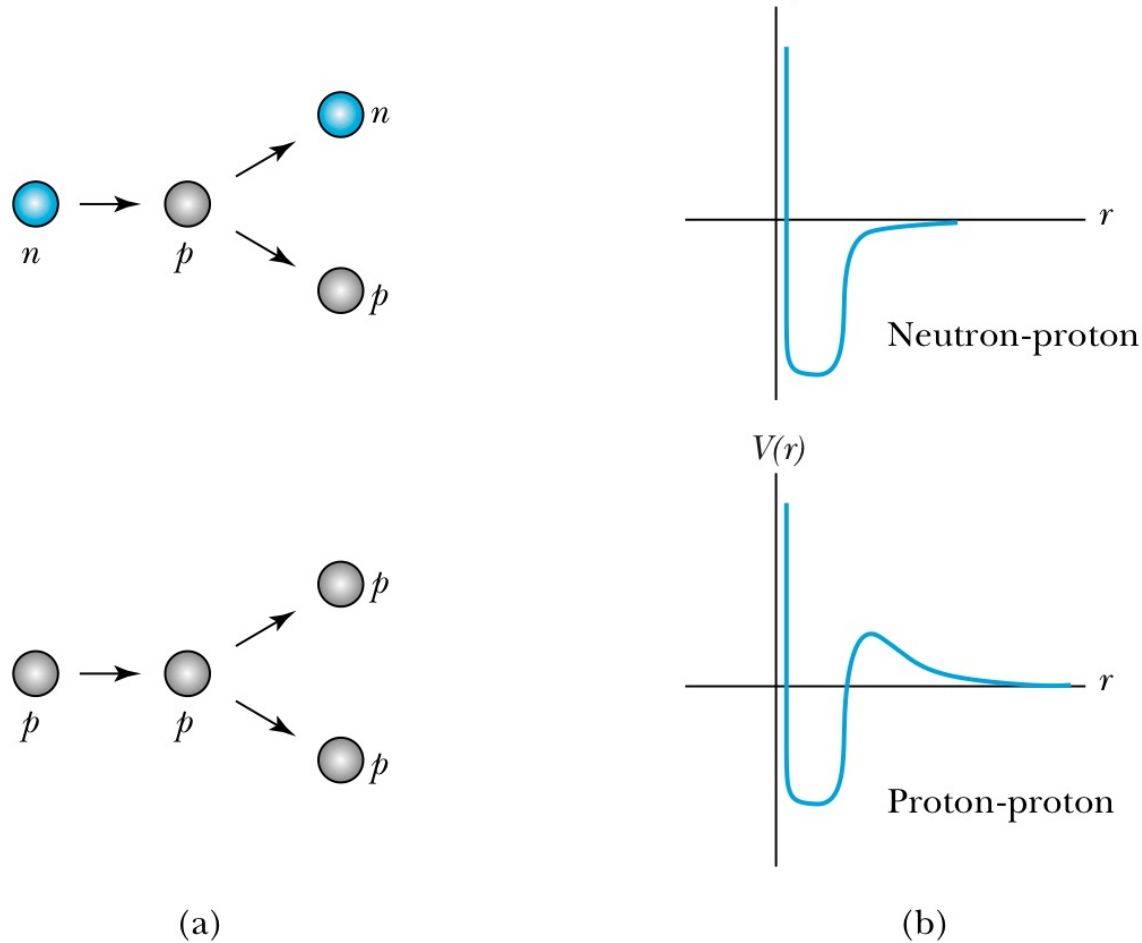

Figure 12.5 (a) A detailed study of neutron + proton and proton + proton scattering reveals (b) the shape of the potential describing each interaction. The proton-proton interaction includes the Coulomb potential (not to scale).

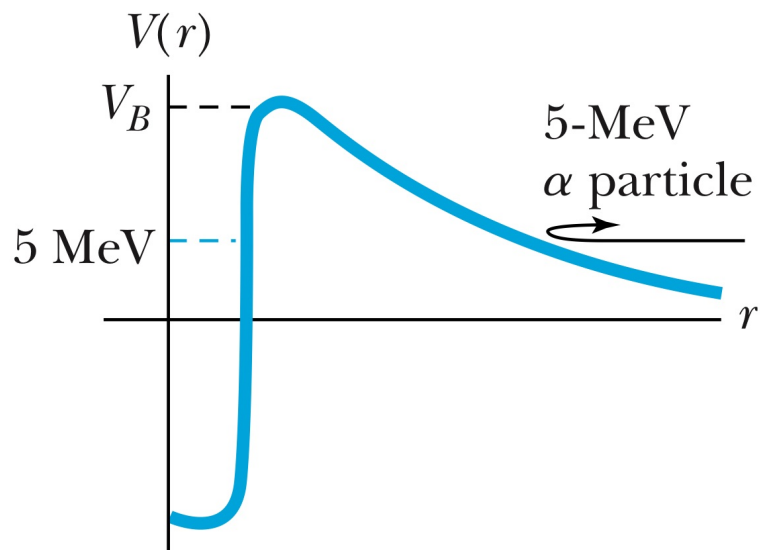
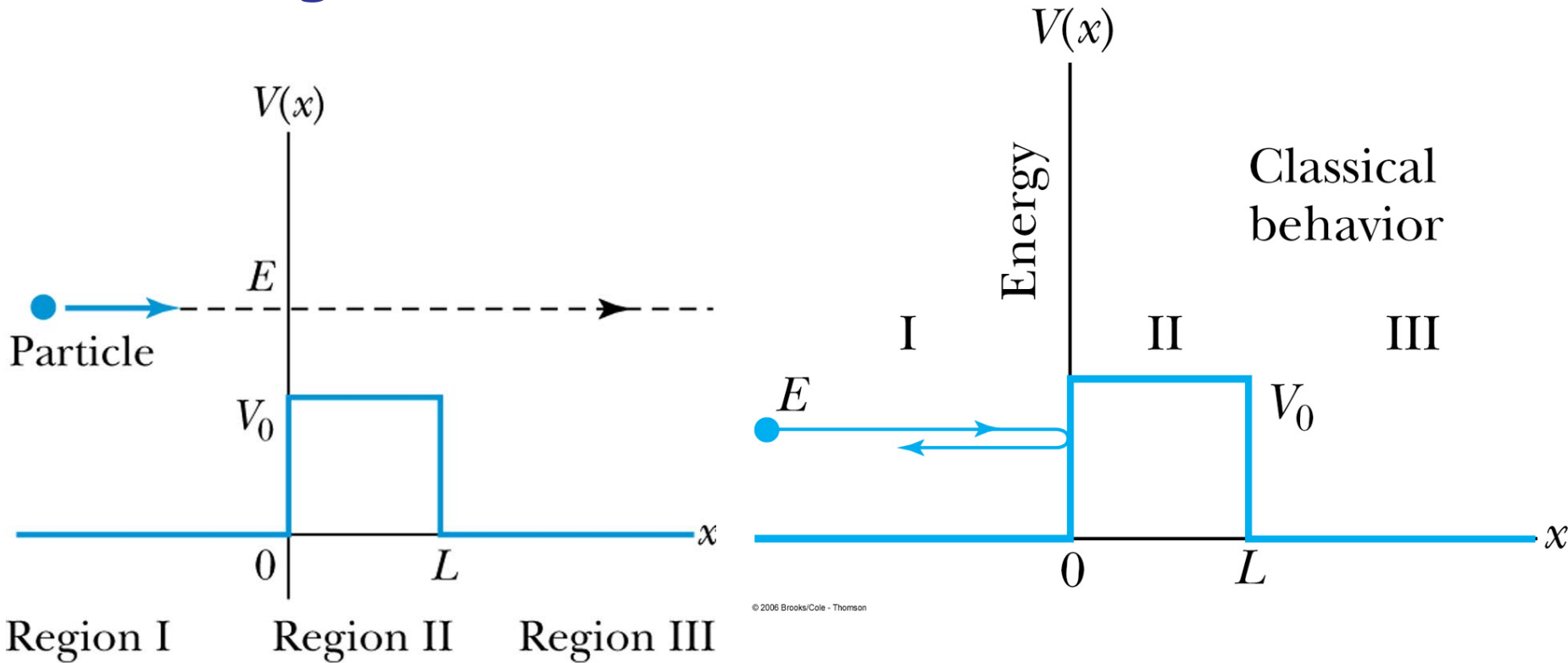

Figure 12.11 The potential energy barrier for an alpha particle is shown. The Coulomb barrier V_B is much greater than the typical alpha-particle energies produced by radioactive sources. Classically a 5-MeV particle inside the nucleus or scattered from outside cannot penetrate the barrier.

Tunneling



© 2006 Brooks/Cole - Thomson

© 2006 Brooks/Cole - Thomson

Classically, if a particle approaches a barrier with $E > V_0$, it is transmitted. If $E < V_0$, the classical particle will be reflected but the quantum particle can also tunnel through.

In Regions I, II and III, the Schroedinger equations are

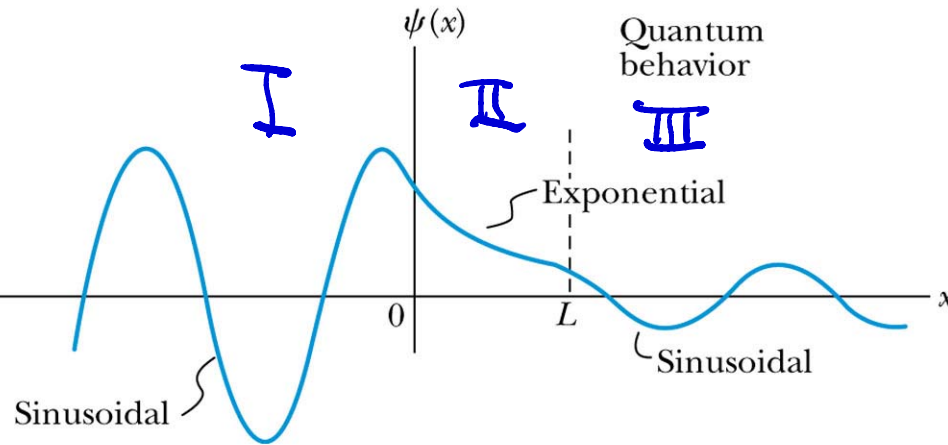

$$e^{\pm kx}$$

$$e^{\pm ikx}$$

$$\frac{d^2 u_I}{dx^2} + \frac{2m}{\hbar^2} E u_I = 0$$

$$\frac{d^2 u_{II}}{dx^2} - \frac{2m}{\hbar^2} (V_0 - E) u_{II} = 0$$

$$\frac{d^2 u_{III}}{dx^2} + \frac{2m}{\hbar^2} E u_{III} = 0$$

$$e^{\pm ikx}$$

$$V_0 > E$$

If we set

$$k = \sqrt{\frac{2mE}{\hbar^2}}, \quad \kappa = \sqrt{\frac{2m(V_0 - E)}{\hbar^2}},$$

the solutions are familiar:

$$u_I(x) = Ae^{ikx} + Be^{-ikx}$$

$$u_{II}(x) = Ce^{-\kappa x} + De^{\kappa x}$$

$$u_{III}(x) = Fe^{ikx} + Ge^{-ikx}.$$

Remember that e^{ikx} moves right and e^{-ikx} moves left. In region III, we can set $G=0$ because there is only a transmitted wave there.

At this point, we match solutions at $x = 0$ and $x = L$, using, for example,

$$\begin{aligned} u_{II}(L) &= u_{III}(L) \\ \frac{du_{II}(L)}{dx} &= \frac{du_{III}(L)}{dx} \end{aligned}$$

with a similar expression connecting u_I and u_{II} at $x = 0$. The interesting quantity is the ratio $|F|^2/|A|^2$ that measures the tunneling probability. Solving for F , one finds

$$\frac{F}{A} = \frac{2e^{-ika}}{[2 \cosh(\kappa a) + i(\kappa/k - k/\kappa) \sinh(\kappa a)]}$$

The tunneling probability is then

$$\frac{|F|^2}{|A|^2} = \left[1 + \frac{V_0^2 \sinh^2(\kappa L)}{4E(V_0 - E)} \right]^{-1}.$$

When κL is large, this becomes

$$\frac{|F|^2}{|A|^2} \rightarrow 16 \frac{E}{V_0} \left(1 - \frac{E}{V_0} \right) e^{-2\kappa L}.$$

Suppose an electron is accelerated through a 5 volt potential and strikes a 10 volt barrier of width 0.8 nm. What fraction of the electrons penetrate the barrier?

Here, $L=0.8$ nm, $V_0=10$ eV, $E=5$ eV and κ is

$$\begin{aligned}\kappa &= \frac{\sqrt{2m(V_0 - E)}}{\hbar} \\ &= \frac{\sqrt{2(0.511 \times 10^6 \text{ eV}/c^2)(10 \text{ eV} - 5 \text{ eV})}}{6.58 \times 10^{-16} \text{ eV s}} \\ \kappa &= \frac{3.43 \times 10^{18} \text{ s}^{-1}}{c} = 1.15 \times 10^{10} \text{ m}^{-1}.\end{aligned}$$

From this, $\kappa L=9.2$, which is large compared to 1. We can then use

$$\frac{|F|^2}{|A|^2} = 16 \left(\frac{5 \text{ eV}}{10 \text{ eV}} \right) \left(1 - \left(\frac{5 \text{ eV}}{10 \text{ eV}} \right) \right) e^{-18.4} = 4.1 \times 10^{-8}.$$

Here, $L=0.8$ nm, $V_0=10$ eV, $E=5$ eV and κ is

$$\begin{aligned}\kappa &= \frac{\sqrt{2m(V_0 - E)}}{\hbar} \\ &= \frac{\sqrt{2(0.511 \times 10^6 \text{ eV}/c^2)(10 \text{ eV} - 5 \text{ eV})}}{6.58 \times 10^{-16} \text{ eV s}} \\ \kappa &= \frac{3.43 \times 10^{18} \text{ s}^{-1}}{c} = 1.15 \times 10^{10} \text{ m}^{-1}.\end{aligned}$$

From this, $\kappa L=9.2$, which is large compared to 1. We can then use

$$\frac{|F|^2}{|A|^2} = 16 \left(\frac{5 \text{ eV}}{10 \text{ eV}} \right) \left(1 - \left(\frac{5 \text{ eV}}{10 \text{ eV}} \right) \right) e^{-18.4} = 4.1 \times 10^{-8}.$$

Here, $L=0.8$ nm, $V_0=10$ eV, $E=5$ eV and κ is

$$\begin{aligned}\kappa &= \frac{\sqrt{2m(V_0 - E)}}{\hbar} \\ &= \frac{\sqrt{2(0.511 \times 10^6 \text{ eV}/c^2)(10 \text{ eV} - 5 \text{ eV})}}{6.58 \times 10^{-16} \text{ eV s}} \\ \kappa &= \frac{3.43 \times 10^{18} \text{ s}^{-1}}{c} = 1.15 \times 10^{10} \text{ m}^{-1}.\end{aligned}$$

From this, $\kappa L=9.2$, which is large compared to 1. We can then use

$$\frac{|F|^2}{|A|^2} = 16 \left(\frac{5 \text{ eV}}{10 \text{ eV}} \right) \left(1 - \left(\frac{5 \text{ eV}}{10 \text{ eV}} \right) \right) e^{-18.4} = 4.1 \times 10^{-8}.$$