



The Glory of Elementary Particle Physics

C.-P. Yuan

Michigan State University

@PHY 215, MSU

April 2026

The Glory of Elementary Particle Physics

C.-P. Yuan

Michigan State University, USA

April 2026 @ PHY 215, MSU

The connection between Cosmology and Particle Physics

- Today's Universe
`Dark' Universe
- Early Universe
Deduced from the
Standard Model of Cosmology
- Elementary Particle Physics
Needed to describe the early universe.

“Dark” Universe

Recent astrophysics data told us that our Universe is made of :

- **stars and galaxies** (ordinary matter) 0.5%
- **Rest of ordinary matter** 4.5%
- **Dark matter** (not ordinary matter) 25%
- **Dark Energy** (filling up empty space) 70%

The “sky”
is made mostly by
something other than
ordinary matter.

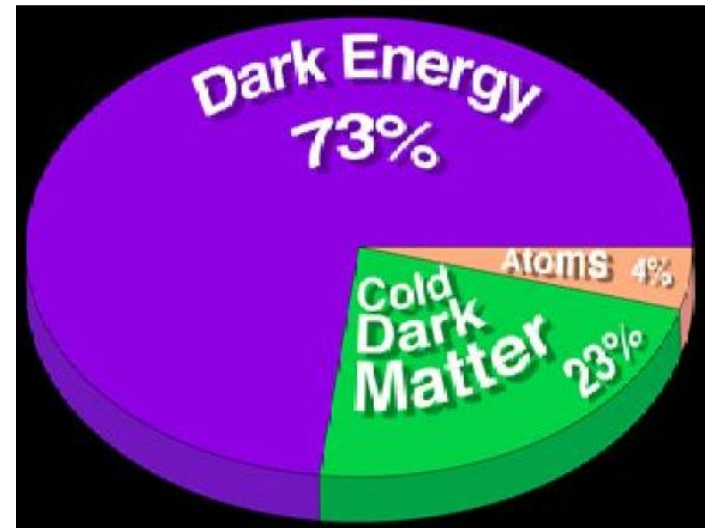

The Energy Budget of the Universe

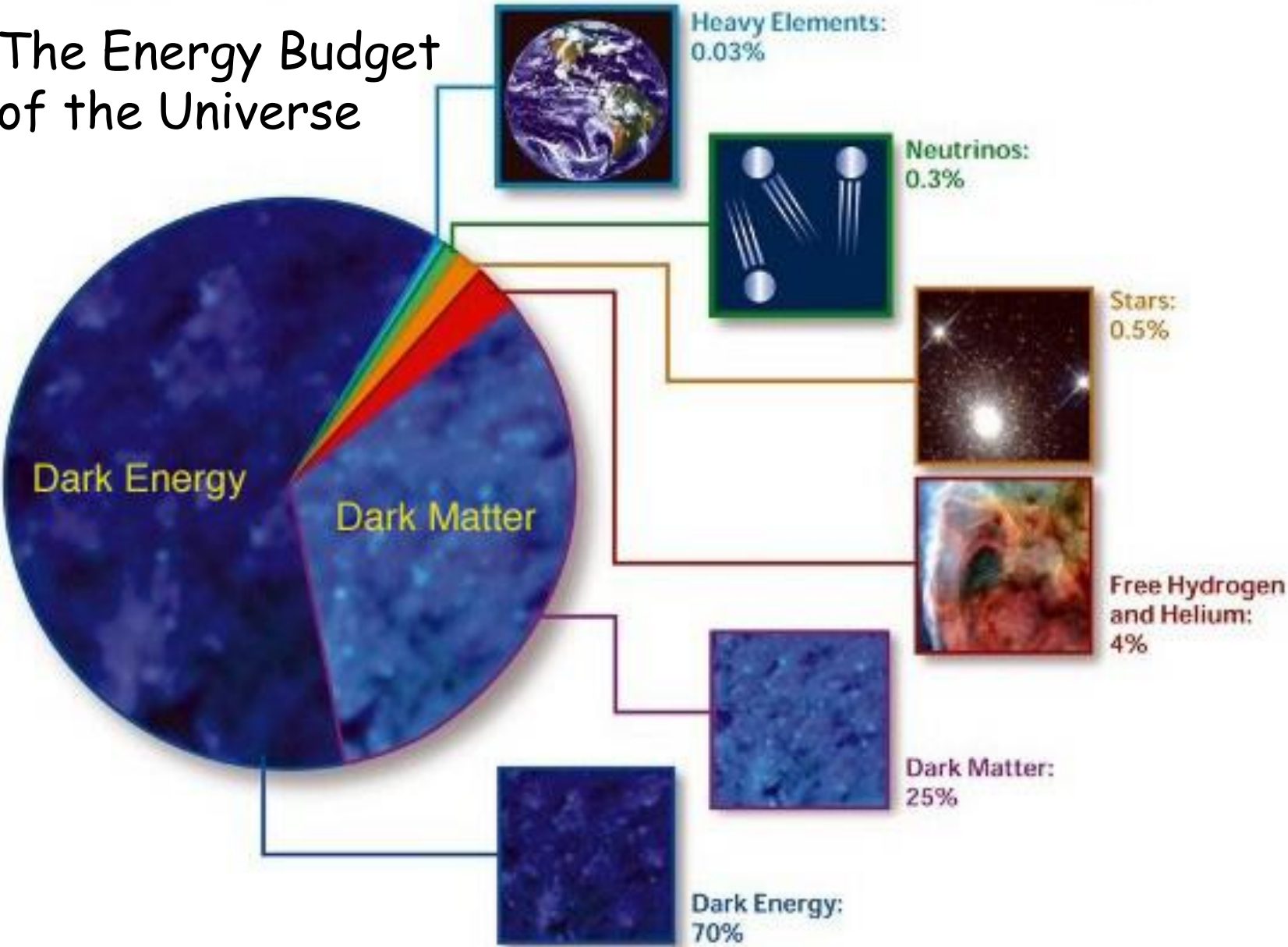

Standard Model of Cosmology

Big Bang Cosmological Model

(Λ – *CDM* Model)

- General Relativity

(Einstein)

- Cosmological Principle

(The three-space of constant time are homogeneous and isotropic at all time)

- Elementary Particle Physics

(To describe particle content of the early universe)

- Λ : Dark Energy

- CDM: Cold Dark Matter

- Ordinary matter: **Standard Model of Particle Physics**

Book Recommendation

The First Three Minutes

by

Steven Weinberg

Describes the history of the early universe, and the history of how we learned about the early universe.

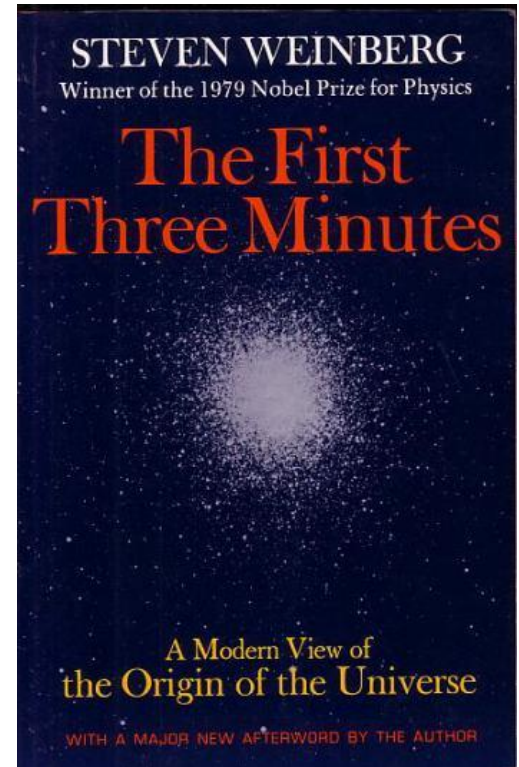

Timeline of the expansion of the universe, where space is represented schematically at each time by circular sections. On the left, the dramatic expansion of inflation; at the center, the expansion accelerates (artist's concept; neither time nor size are to scale).

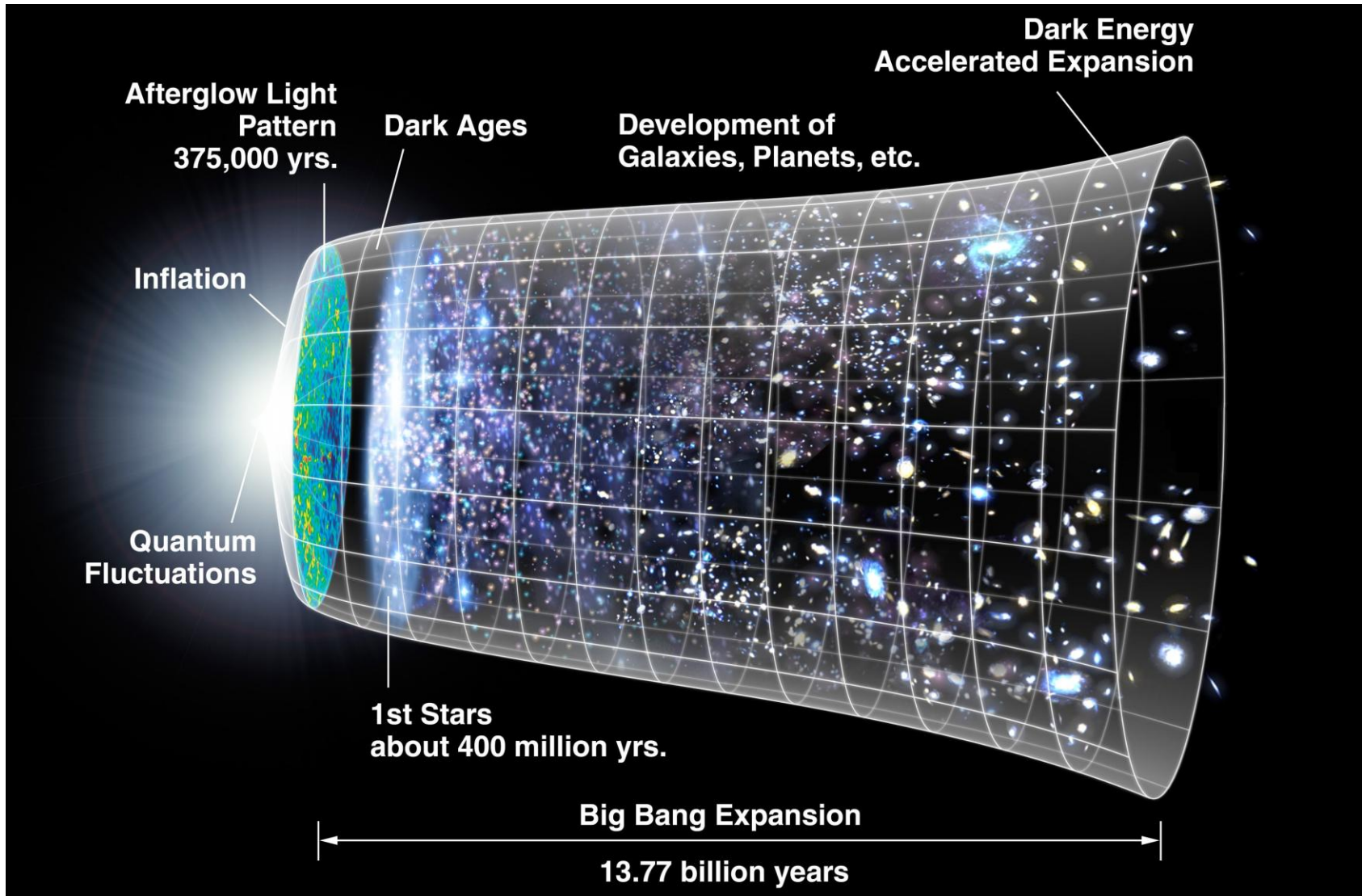

History of the Universe

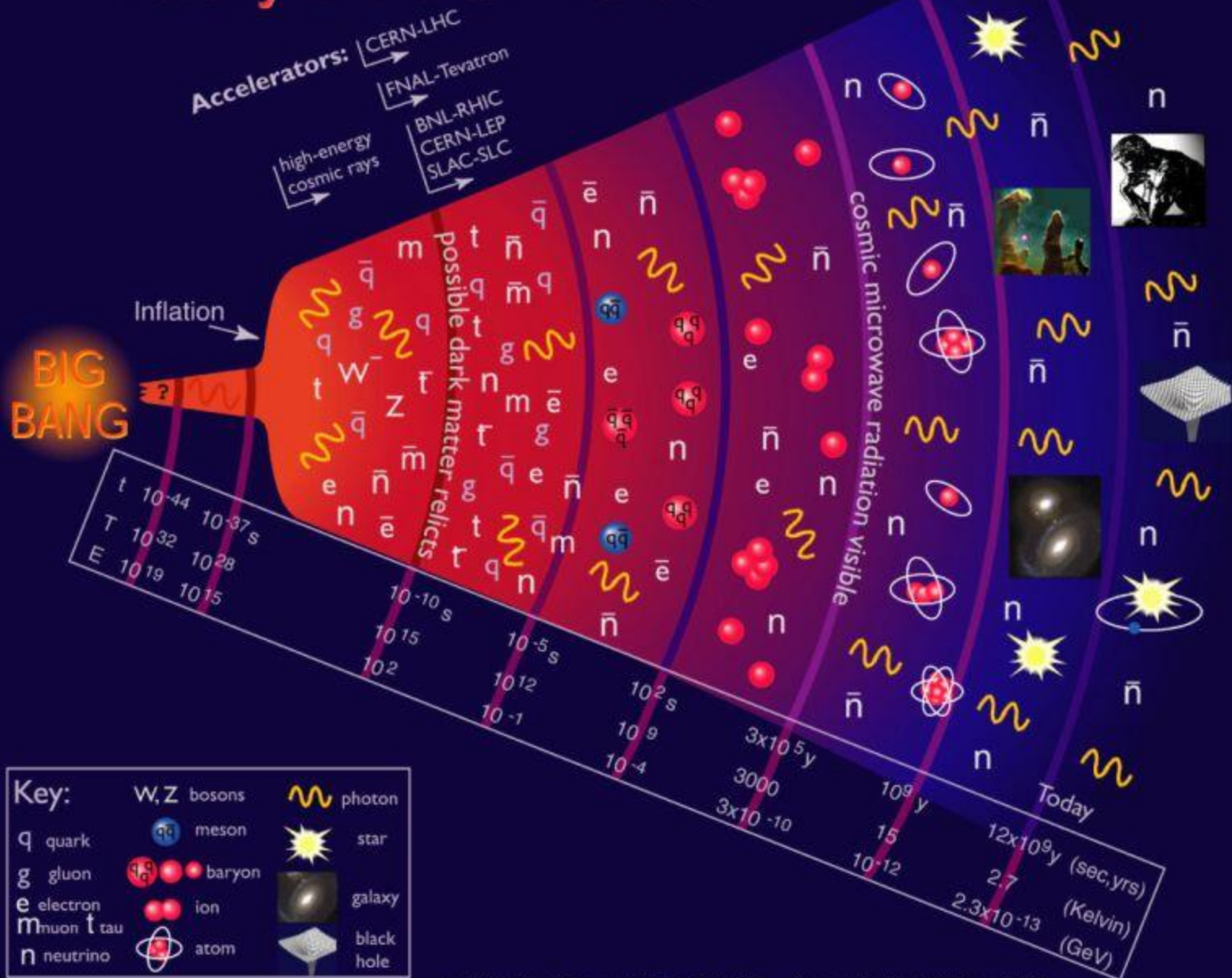

Ultimate Time Machine

- Doing astronomical observations is like travelling back in time
- If an galaxy is 1 million light years away, then the light that you are seeing left that galaxy 1 million years ago, and you are seeing what it looked like long ago
- Do the Time Machine Activity

Particle physics looks at matter in its smallest dimensions.

Astrophysics looks at matter in its largest dimensions.

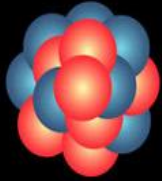

10^{-15} 10^{-12} 10^{-9} 10^{-6} 10^{-3} 10^0 10^3 10^6 10^9 10^{12} 10^{15} 10^{18} 10^{21} 10^{24}

They are related!

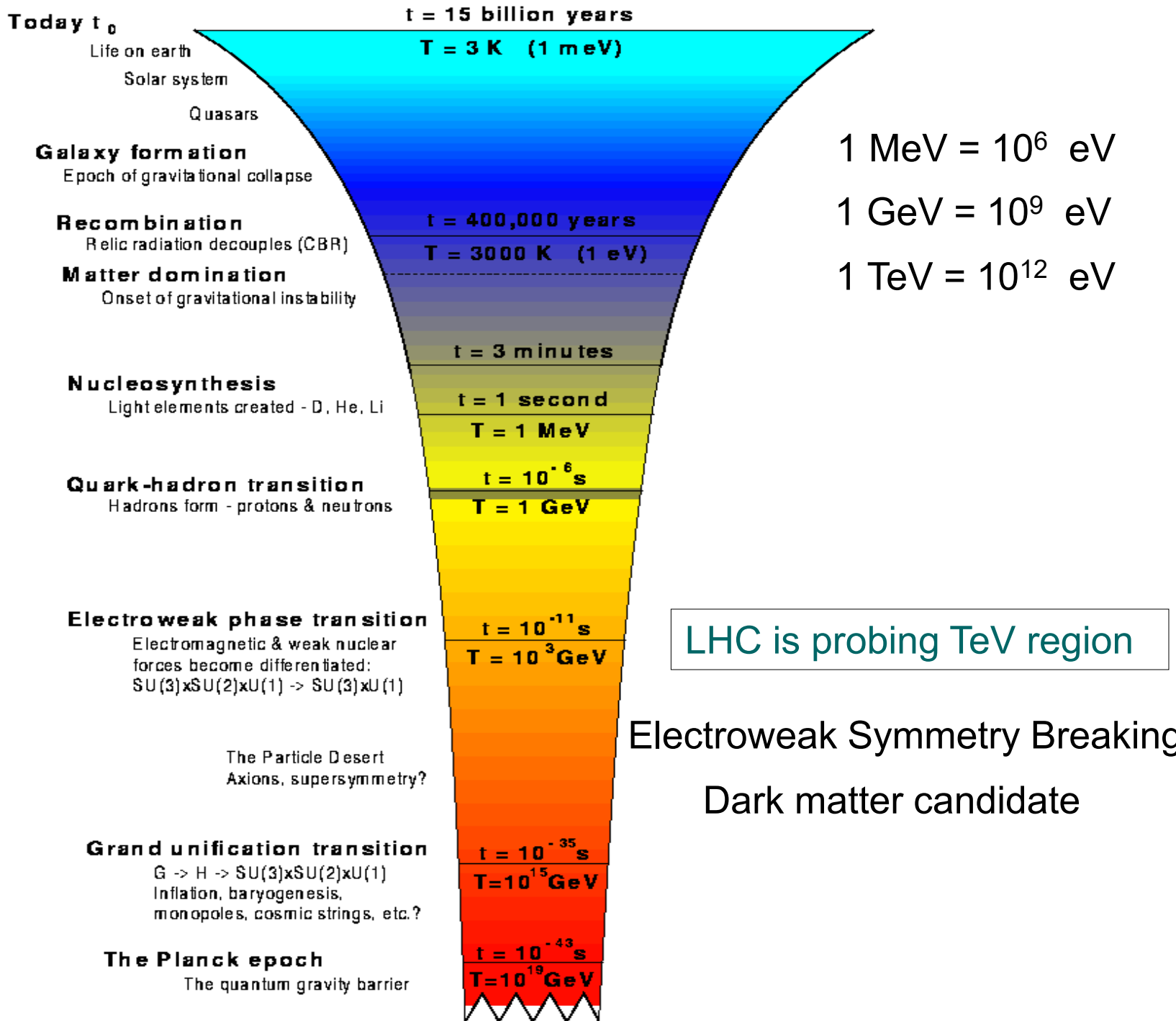

$$1 \text{ GeV} = 10^9 \text{ eV}$$

$$1 \text{ TeV} = 10^{12} \text{ eV}$$

LHC is probing TeV region

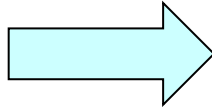

It is about
0.000000000001 second
after Big Bang,
or,
about 14 billion years ago.

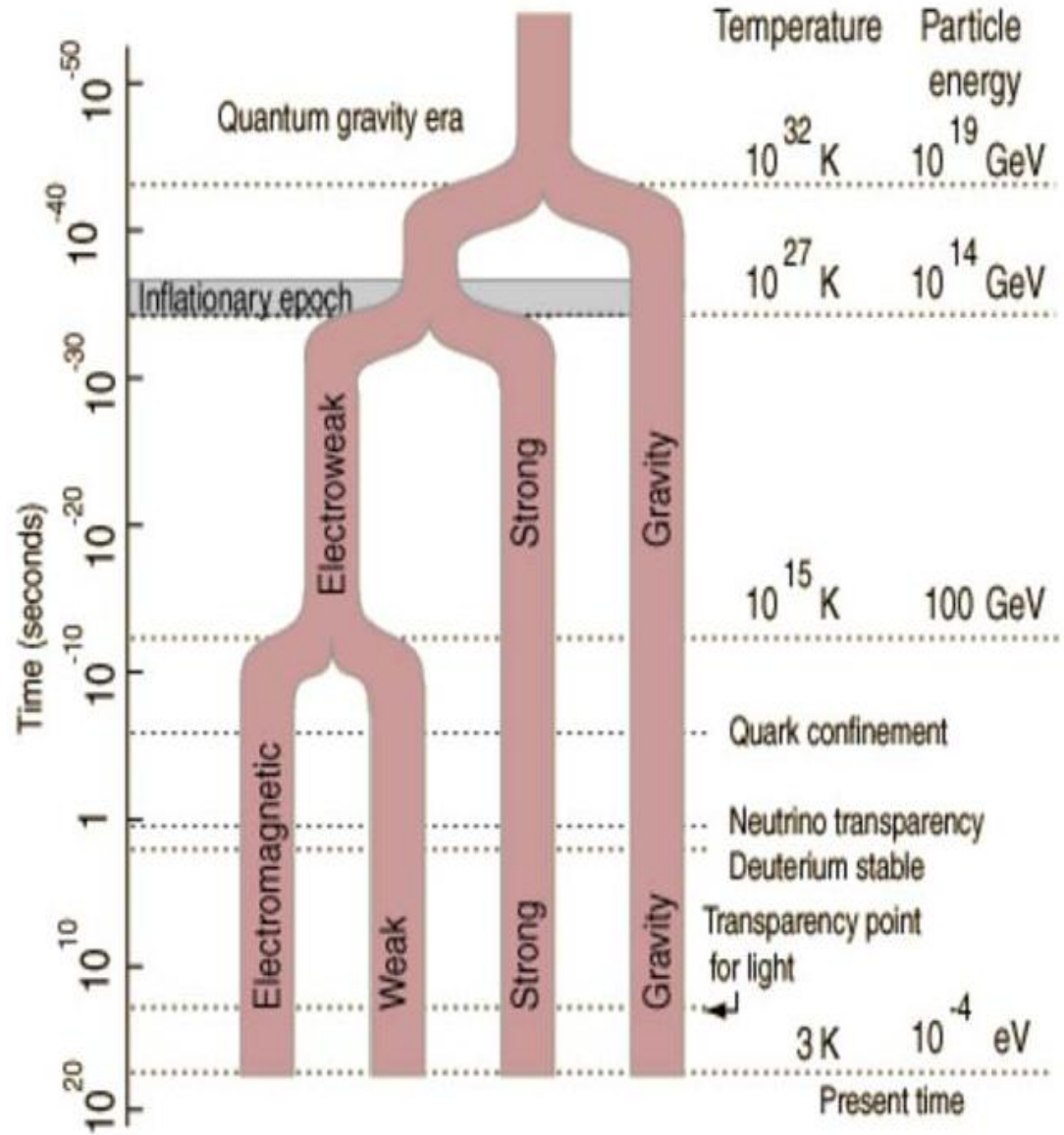

Early universe chronology

CERN LHC (Large Hadron Collider)

The highest energy
Proton-proton collider
In the world.

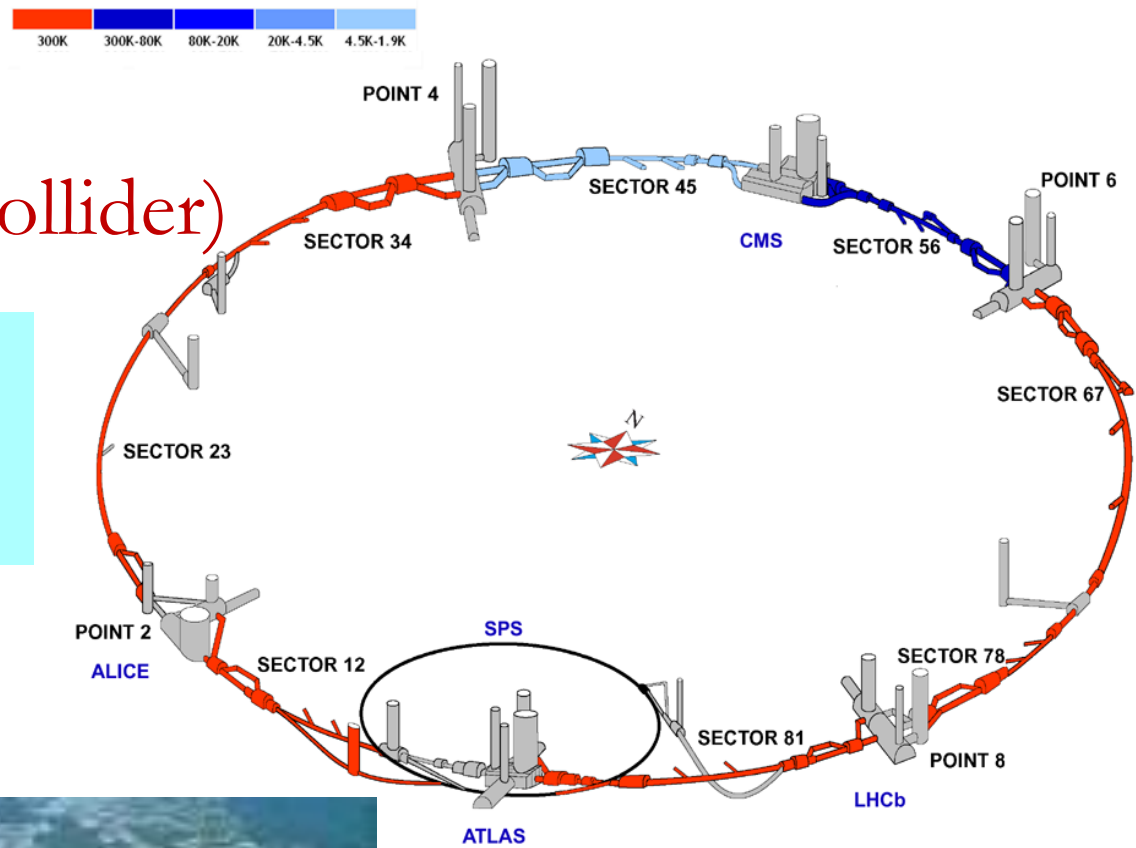

The Large Hadron Collider (LHC) is a 27km long circular accelerator built at CERN, near Geneva Switzerland. The tunnel is buried around 50 to 175 m underground.

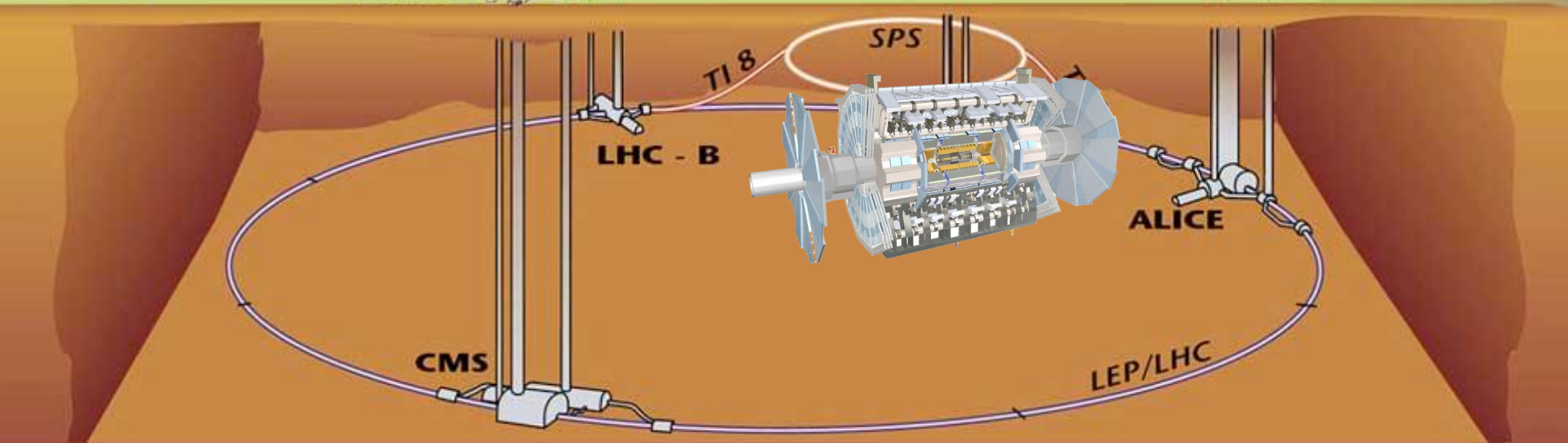
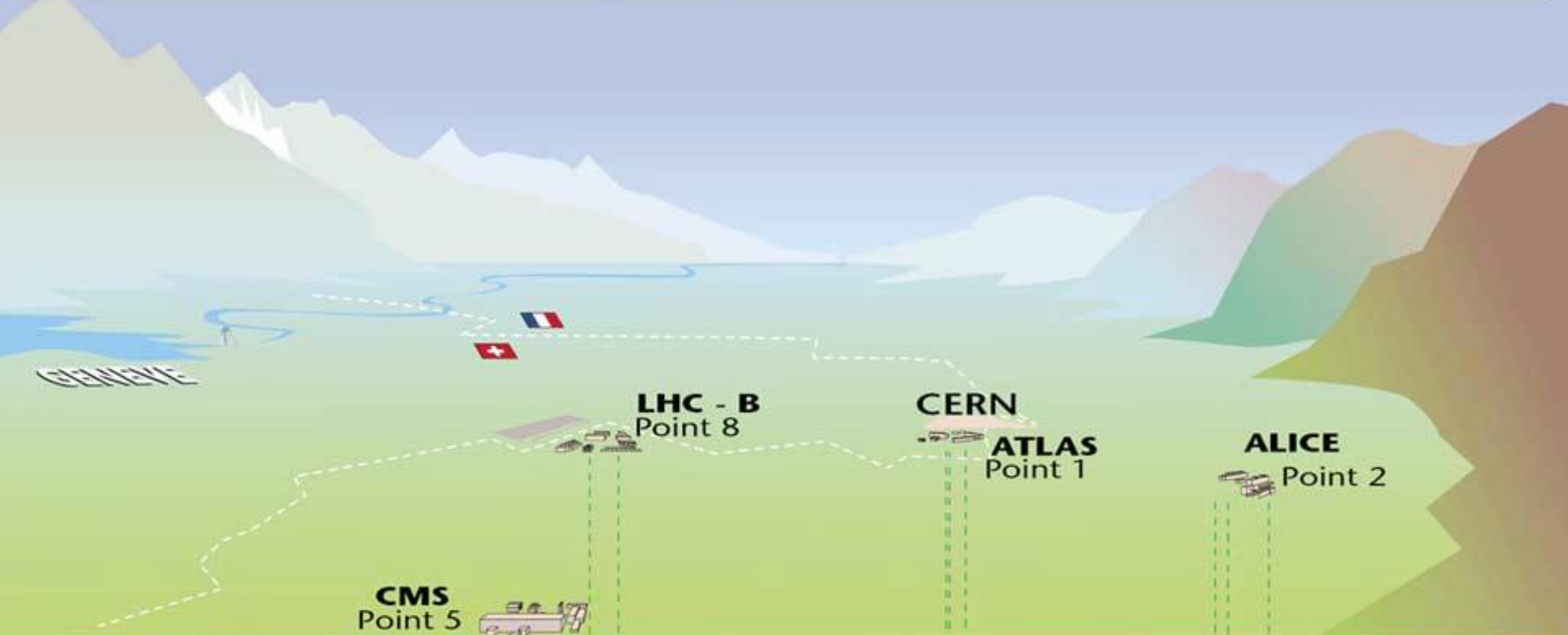

Elementary Particle Physics

To answer



**What are the Elementary
Constituents of Matter?**

**What are the forces that
control their behaviour at
the most basic level?**

Science Is About Simplification

- Why do so many things in this world share the same characteristics?
- People have come to realize that the matter of the world is made from a few **fundamental** building blocks of nature.

(“**Fundamental**” here means simple and structureless --- not made up of anything smaller.)



What is the Ultimate Structure of Matter?

- In 1900's the fundamental particle is atom

But, is the atom fundamental?

H																			He
Li	Be											B	C	N	O	F		Ne	
Na	Mg											Al	Si	P	S	Cl		Ar	
K	Ca	Sc	Ti	V	Cr	Mn	Fe	Co	Ni	Cu	Zn	Ga	Ge	As	Se	Br		Kr	
Rb	Sr	Y	Zr	Nb	Mo	Tc	Ru	Rh	Pd	Ag	Cd	In	Sn	Sb	Te	I		Xe	
Cs	Ba		Hf	Ta	W	Re	Os	Ir	Pt	Au	Hg	Tl	Pb	Bi	Po	At		Rn	
Fr	Ra		Rf	Db	Sg	Bh	Hs	Mt	Uun	Uuu	Uub								
			La	Ce	Pr	Nd	Pm	Sm	Eu	Gd	Tb	Dy	Ho	Er	Tm	Yb		Lu	
			Ac	Th	Pa	U	Np	Pu	Am	Cm	Bk	Cf	Es	Fm	Md	No		Lr	

- Periodic Table of Elements (Atoms could be categorized into groups that shared similar chemical properties) suggest:
atom has substructure!

Photons hold atom together

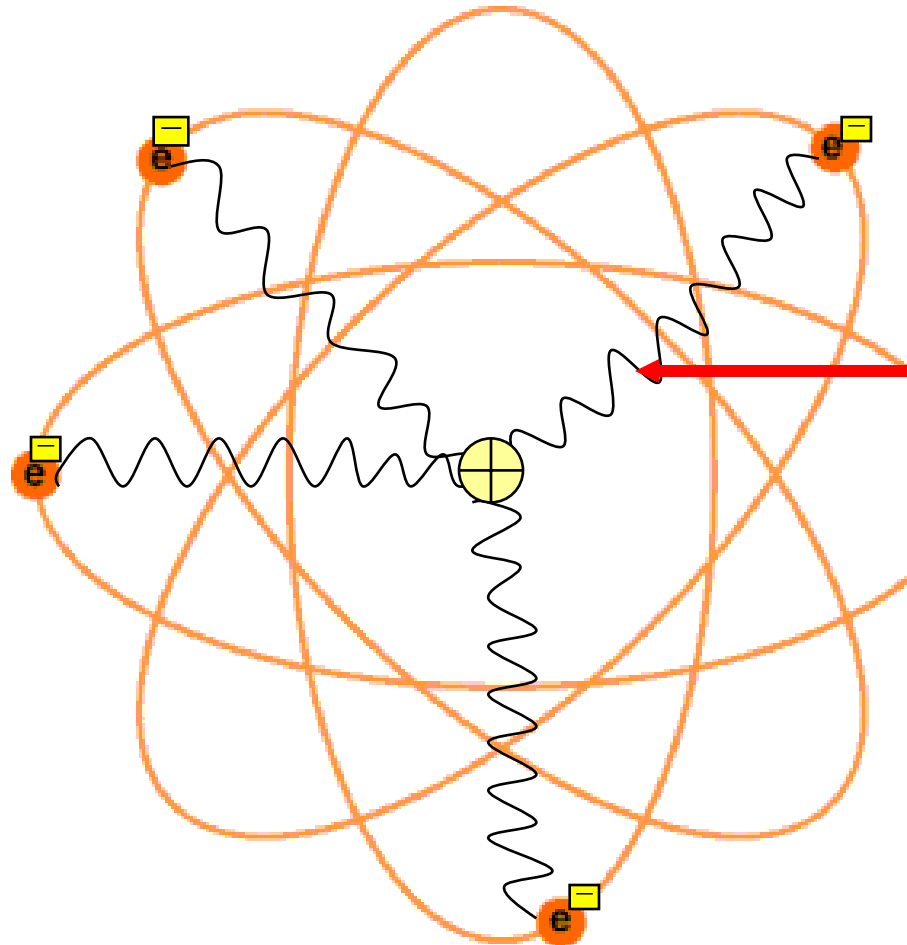

Usually we call the electromagnetic interaction between nuclei and electron “Columb force”!

The quanta of the electromagnetic force is photon.

The electrical attraction is caused by the exchange of photon.

(This is finally understood by Quantum Electrodynamics)

Feynman, Schwinger, Tomonaga, 1965 Nobel Prize

How to form stable molecules from atoms?

- Since atoms are electrically neutral, what causes them to stick together to form stable molecules?
- The answer is a bit strange: an effect called the **residual electromagnetic force** allows different atoms to bind together and form molecules.

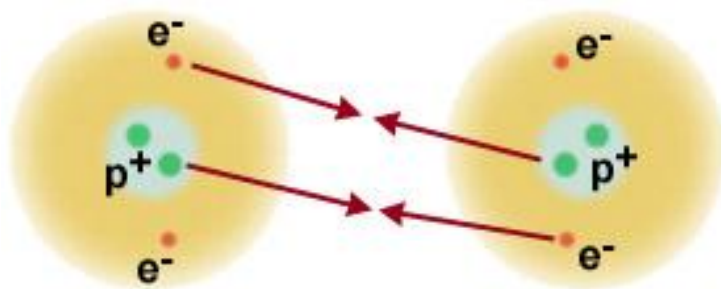

Residual E-M force in action: the atoms are electrically neutral, but the electrons in one are attracted to the protons in another, and vice versa!

Amazing, isn't it?

All the structures of the world exist simply because protons and electrons have opposite charges!

Is the Nucleus Fundamental?

- In an atom, outside of the nucleus is a cloud of negatively charged **electrons** (e).
- Experiments “looked” into the nucleus (and atoms) using **particle probes** to learn more about it.
- They discovered that the nucleus was made of **protons** (p), which are positively charged, and **neutrons** (n) which have no charge.

Proton Rutherford 1911; neutron Chadwick 1932



Nuclear Force hold Nucleus together

- Electromagnetic force hold atom together by exchanging photons.
- Similarly, Yukawa suggested:
nuclear force hold nucleus together by exchanging Pion mesons (predicted in 1935).
- Powell found charged pion in 1947.

Yukawa 1949 Nobel Prize

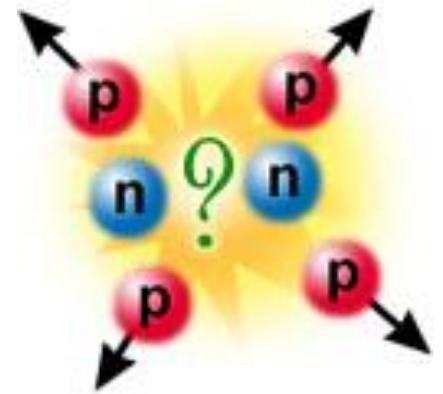

Botanic Garden of Particles

- Before 1937, the view of our world was simple: **matter is made of proton, neutron and electron.**
- By 1960's, more than 60 **new particles** (most of which aren't fundamental) were found: e.g.

K^0

K^+

π^0

Kaons (Rochester, Butler, 1947)

(Powell, 1949)

Neutral pion (1950)

- Physicists were trying to find any “**pattern**” among those newly discovered particles, similar to the invention of “**Periodic Table of Elements**” to organize different atoms.
- **If a pattern exists, it implies those newly discovered particles are not fundamental.**

Are Protons and Neutrons Fundamental?

- Gell-mann found the pattern among proton, neutron pion, kion, ..., called “The Eightfold Way” (“Quark Model”)
- Protons and neutrons are composed of even smaller particles called **Quarks**.

Proton = (u u d) u = up quark

Neutron = (u d d) d = down quark

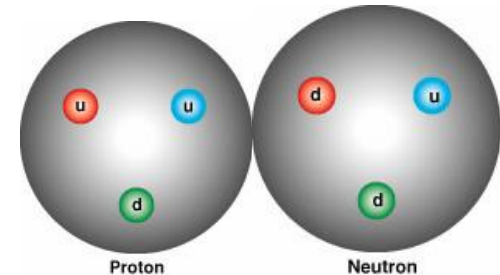

- Other particles like pion, kion, ..., are also composed of quarks. (**Baryon: (qqq)** , **Meson: (q \bar{q})**)

Gell-Mann, 1969 Nobel Prize

Quarks

- There are three pairs of quarks.
- The up and down are the constituents of protons and neutrons, and make up most matter.
- The other particles are produced in energetic subatomic collisions from cosmic rays or in accelerators like Fermilab.

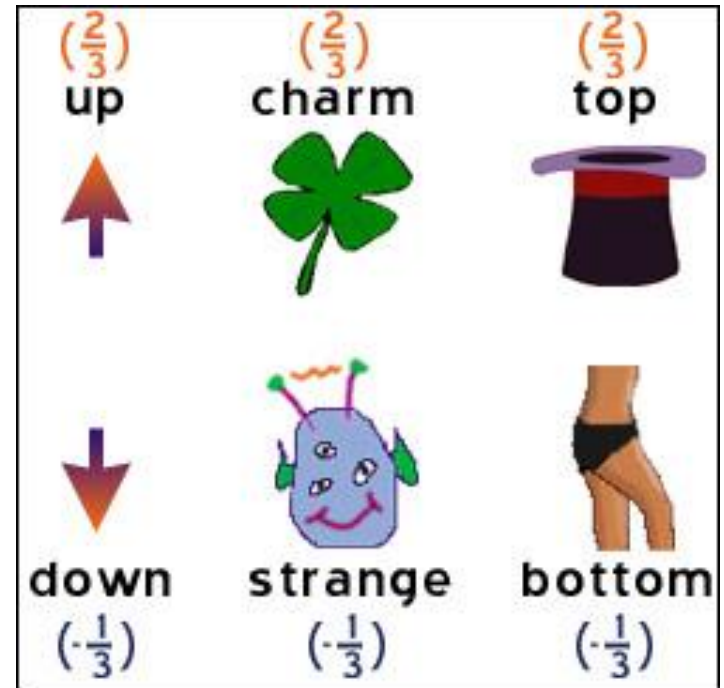

- 1974 November Revolution, Ting, Richer found charm quark.
- 1977, Lederman found bottom quark.
- 1995, Fermilab found top quark.

Gluons bind quark together

- Quarks have electric charge, and they also have another kind of charge altogether called color charge. The force between color-charged particles is very strong, so this force is creatively called strong force.
- The strong force holds quarks together to form hadrons, so its carrier particles are whimsically called **gluons** because they so tightly "glue" quarks together

Gluons bind quark together

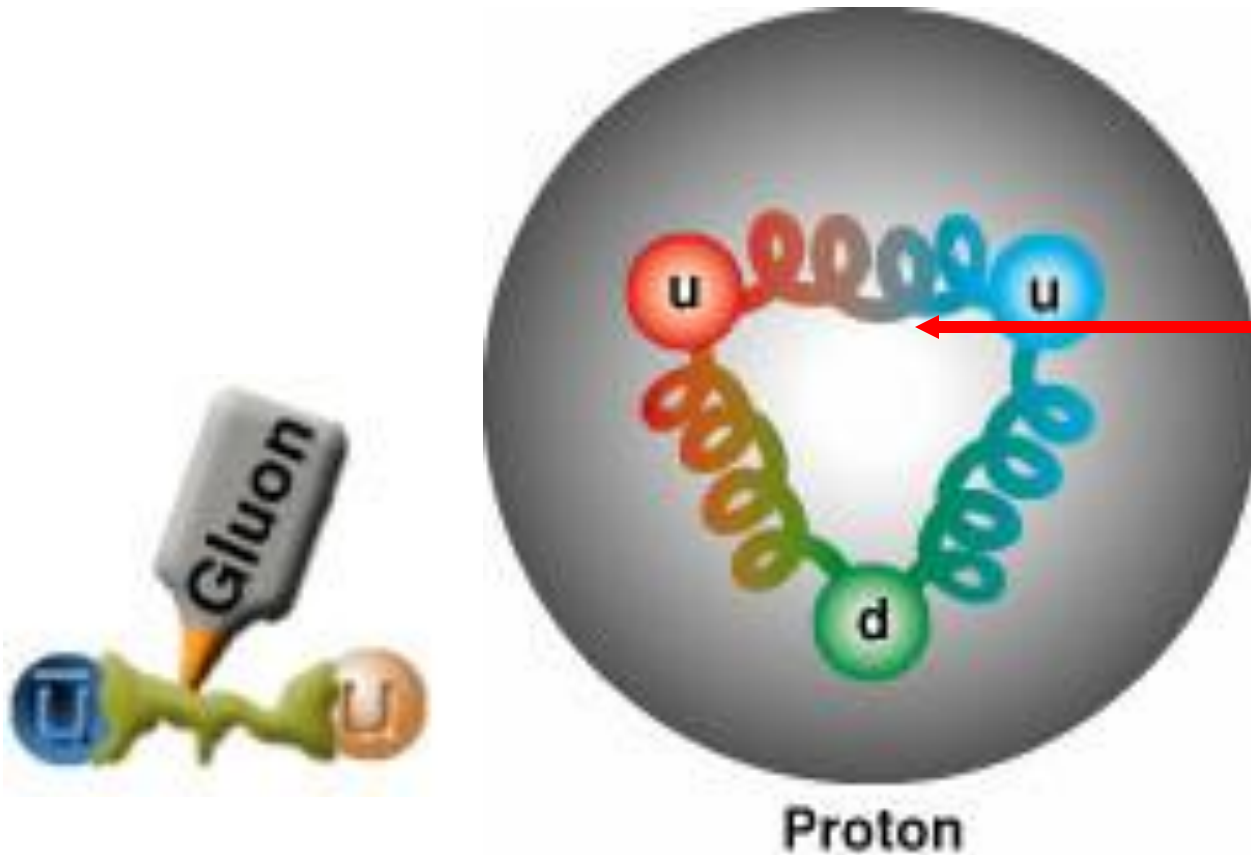

The quarks are stuck together by the exchange of gluon, which is finally understood by Quantum Chromodynamics (*Asymptotic Freedom* in high energy).

1973 DESY(PETRA): confirm gluon in $e^+ e^- \rightarrow 3 \text{ jets}$

Gross, Wilczek, Politzer, 2004 Nobel Prize

Gluons bind quark together

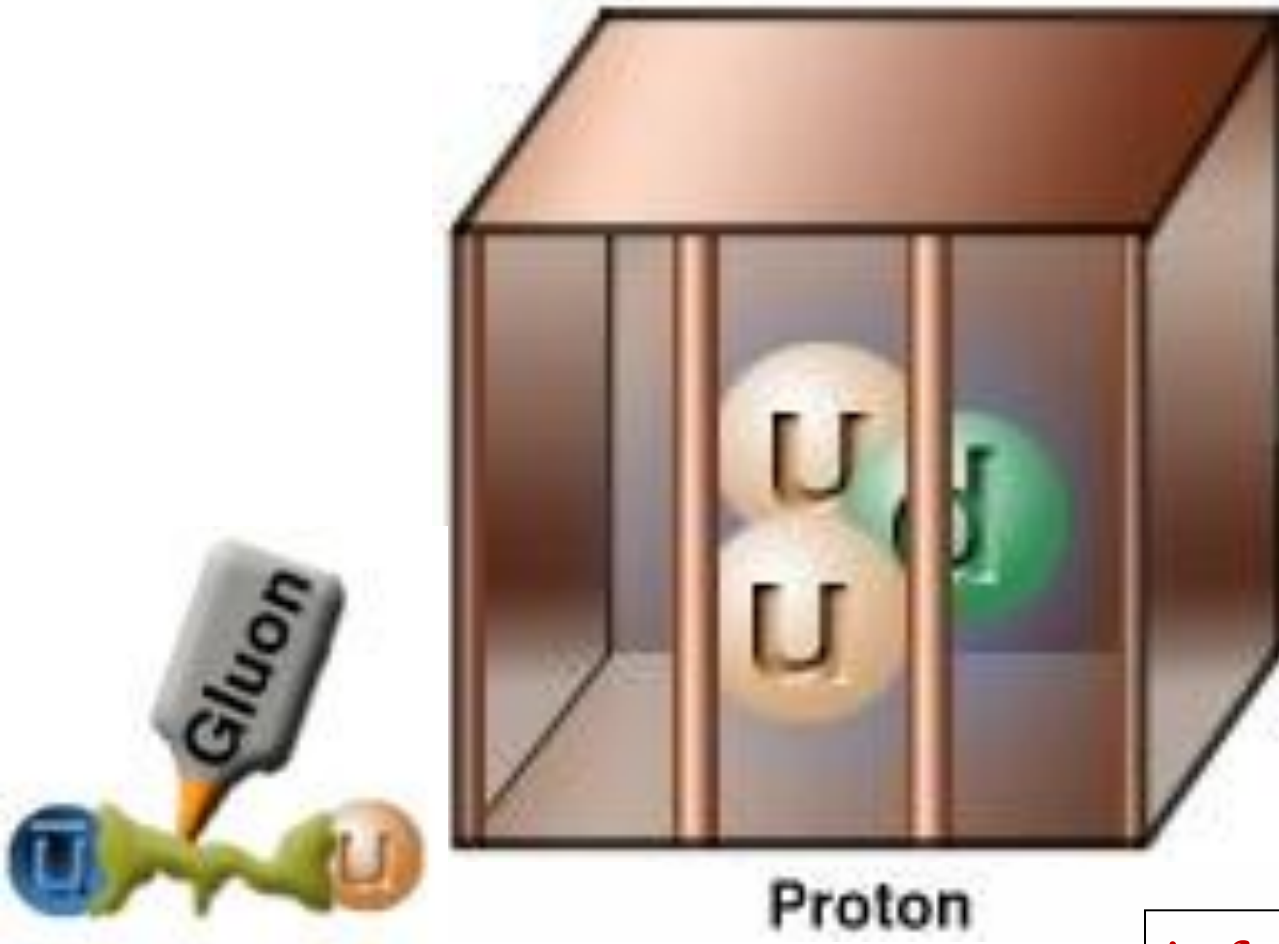

In low energy, we can't see free quark. The quarks are confined inside the proton.

1 million dollars problem!

infrared confinement

The origin of nuclear force

- Now back to the nucleus!
- The nucleus of an atom consists of a bunch of protons and neutrons crammed together. Since neutrons have no charge and the positively charged protons repel one another, **why doesn't the nucleus blow apart?**
- We cannot account for the nucleus staying together with just electromagnetic force. What else could there be?

The residual strong gluon force

- While quarks have color charge, composite particles made out of quarks have **no net color charge** (they are color neutral). For this reason, strong force only takes place on the really small level of quark interactions, which is why you are not aware of strong force in your everyday life.
- The residual strong gluon force between the protons and neutrons overwhelms the repulsive electromagnetic force.
- It is what "glues" the nucleus together.



Until now, we know...

Sizes and distance scales

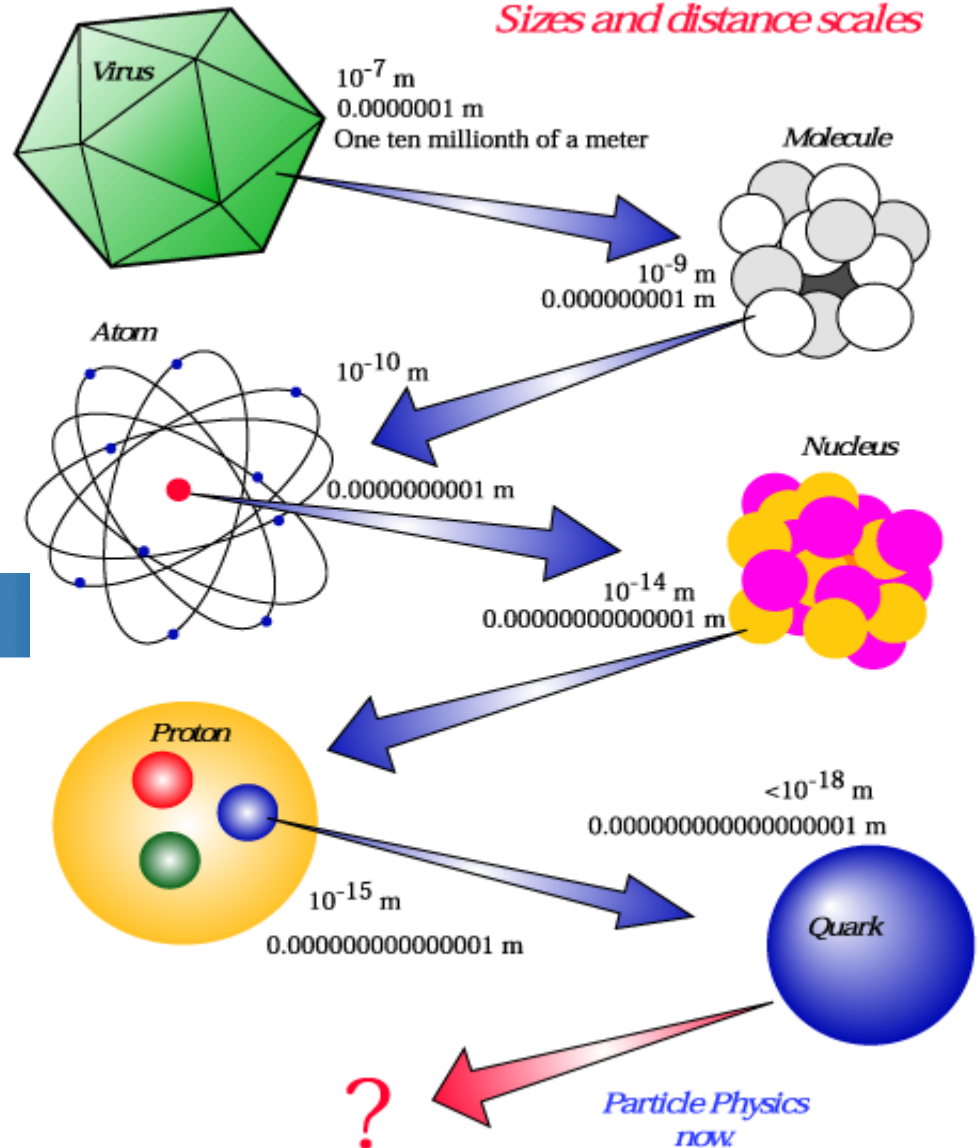

Constituents of Matter

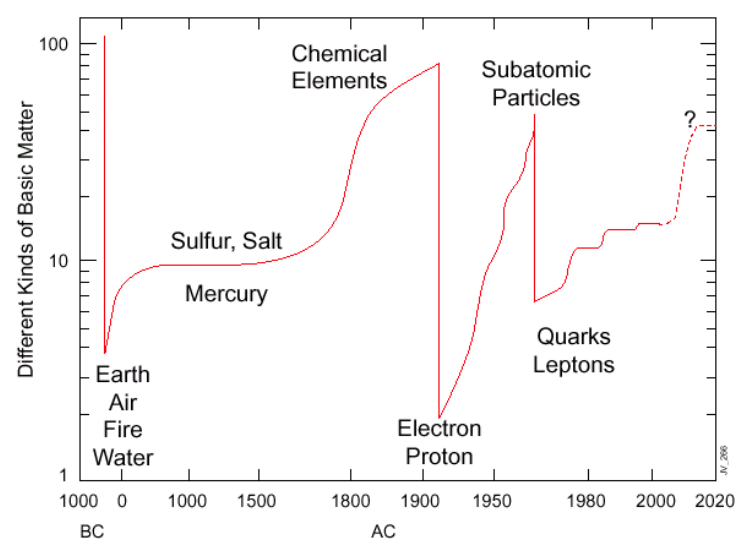

Sumarize:

The modern atom model

- **Electrons** are moving constantly around **nucleus** which is made of **protons** and **neutrons** which are the composites of **quarks**.

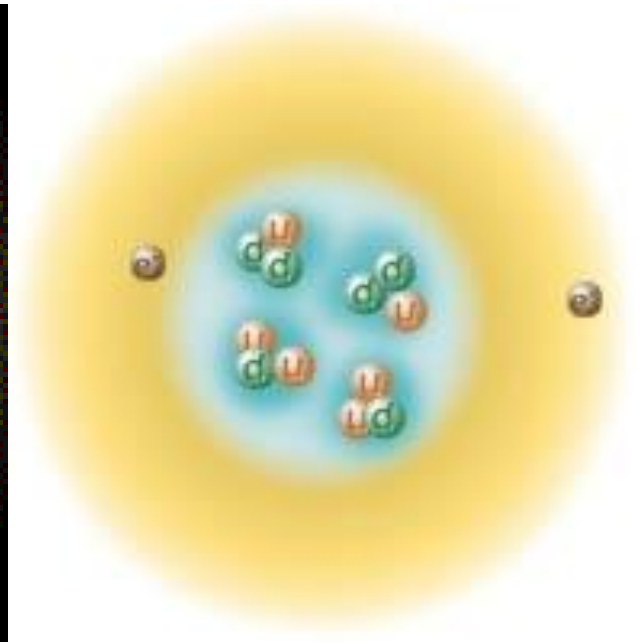
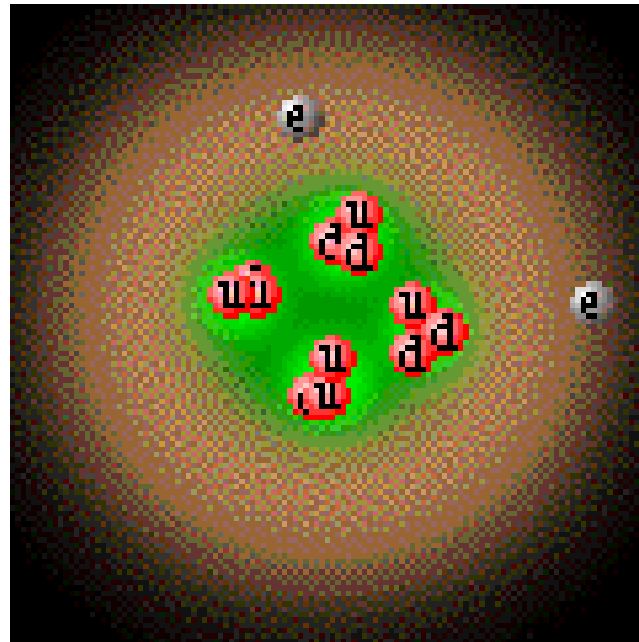

99.9999999999999999% of an atom's volume is just empty space!

- If we drew atom to scale and made protons and neutrons a centimeter in diameter, then electrons and quarks would be less than the diameter of hair, and the entire atom's diameter would be greater than the length of 30 football fields!

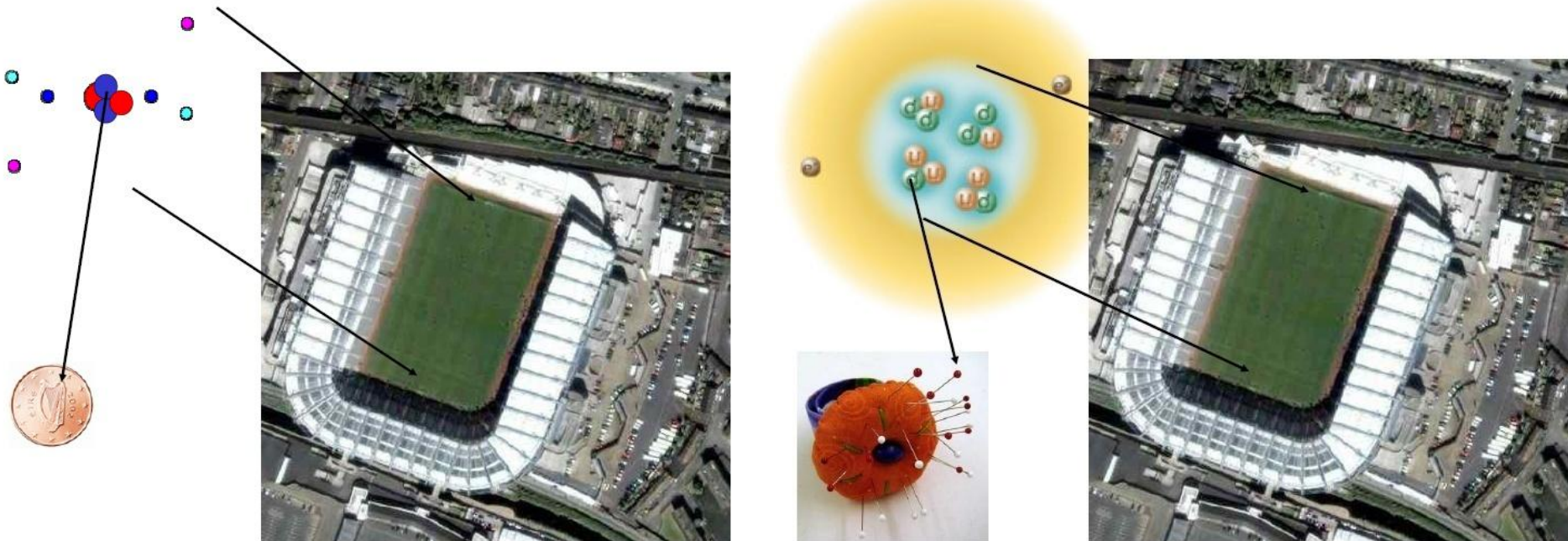

Empty Space?

- The “little universe” of atom is occupied mostly by “Emptiness”.
- In fact, the 3 (u u d) quarks inside the proton only occupy one part in a billion (10^{-9}) of the proton’s volume.

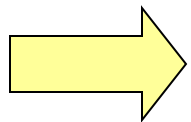

Lots of “Emptiness”

What is The True Nature of Emptiness?

Interactions Generate Mass

- Quarks themselves only contribute a very small part, about 1.3%, of the proton (uud) mass:
- 99.7% of proton mass originates from the interactions among the 3 quarks inside proton. (Mass is a form of kinetic and potential energy.)

Nambu (Nobel Prize 2008)

- These energies are converted into the mass of the proton as described by Einstein's equation that relates

Energy (E) to Mass (M) by

$$E = M c^2$$

C is the speed of light = 3×10^8 meters per second.

The **Emptiness** inside a Proton

- More than **99.99999999%** of the proton's volume is empty space!
- The mass of proton is mainly generated by the contribution from the empty space (**Emptiness**) inside the proton.

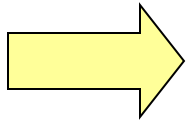

“Emptiness” is not “void”.

Mass is a form of **Energy**.

The Modern Proton

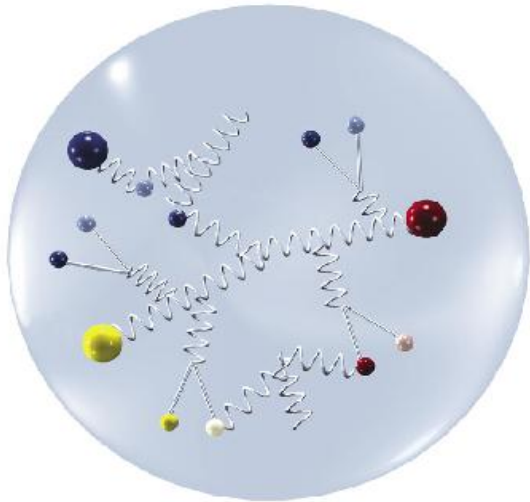

The Proton

Mostly a very dynamic self-interacting field of gluons, with three quarks embedded.

Like plums in a pudding.

- 99% of the proton's mass/energy is due to this self-generating gluon field
- The two u-quarks and single d-quark
 - 1. Act as boundary conditions on the field (a more accurate view than generators of the field)
 - 2. Determine the electromagnetic properties of the proton
 - *Gluons are electrically neutral, so they can't affect electromagnetic properties*
- The similarity of mass between the proton and neutron arises from the fact that the gluon dynamics are the same
 - Has nothing to do with the quarks

The key point is

Antimatter

Antimatter

- Dirac's theory of electron (1920's), consistent with **Quantum Mechanics** and Einstein's **Special Theory of Relativity**, predicts that:
 - For every type of **matter particle** we've found, there also exists a corresponding **antimatter particle**, or **antiparticle**.
 - Pure energy can **create a pair of particle and antiparticle**.
 - When a matter particle and antimatter particle meet, they **annihilate into pure energy!**

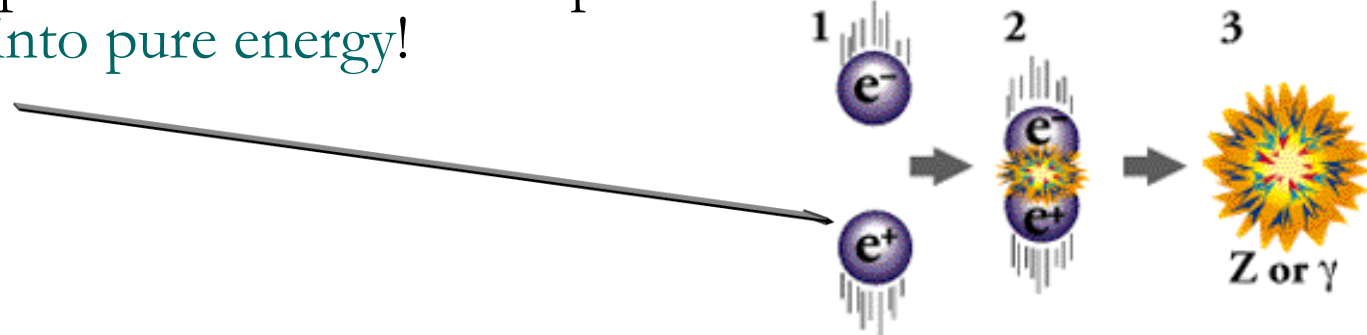

Evidence for anti-matter

- This is a **bubble chamber** photo
- There is a collision of a proton into a target. The bubble chamber is in a magnetic field.
- Can you spot the anti-matter?
 - The magnetic field makes negative particles curl one way and positive particles the other.
 - **Positrons (anti-electrons)** behave just like the electrons but curl in the opposite way because they have the opposite charge.
 - **Electron-positron pairs** appear as if from nowhere, but are in fact from photons, which don't leave a trail.

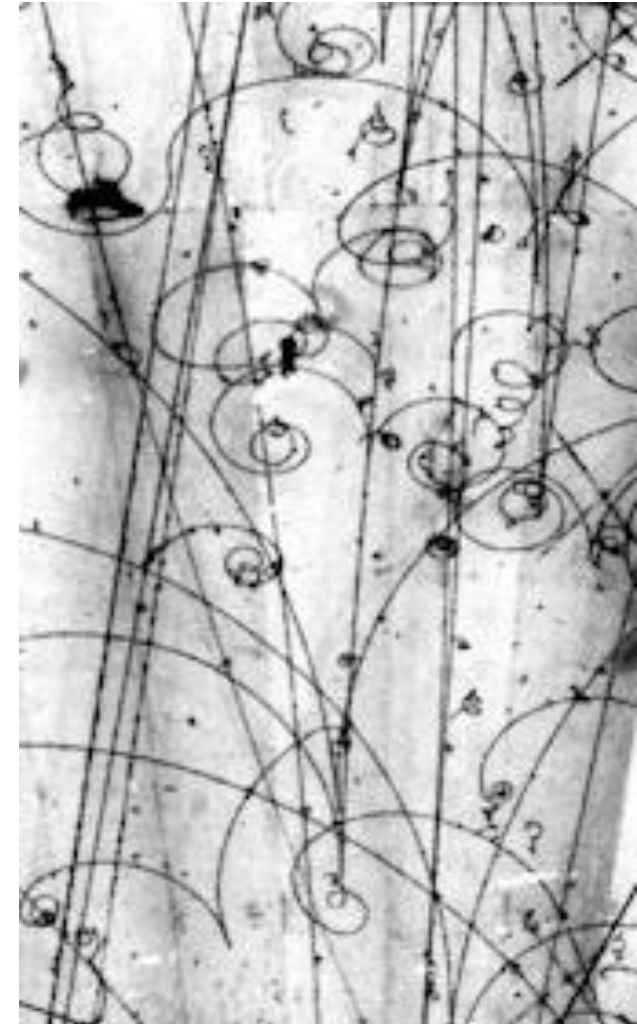

CARL D. ANDERSON

The production and properties of positrons

Nobel Lecture, December 12, 1936

Annihilation

- In an annihilation, **a matter and an antimatter particle completely annihilate into energy.**
- During an annihilation, a matter and antimatter particle interact with each other, converting the energy of their previous existence into a very energetic force carrier particle (**a gluon, W/Z, or photon**). These force carriers, in turn, are transformed into other particles.
- This is what we did at **Fermilab, USA** -- **annihilate two particles at tremendous energies in order to create new, massive particles.**

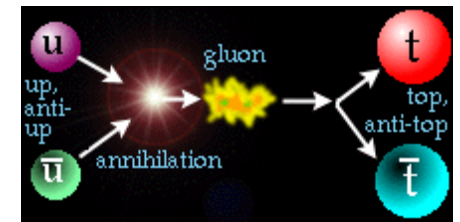

Top Quark and Anti-Top Quark Pair Production at Hadron Collider

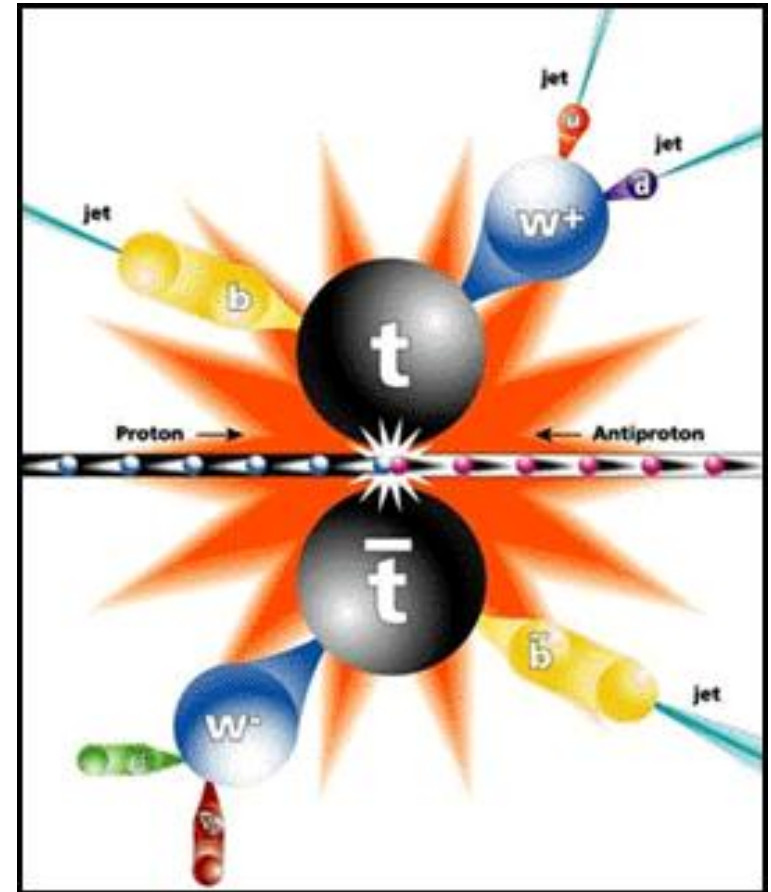
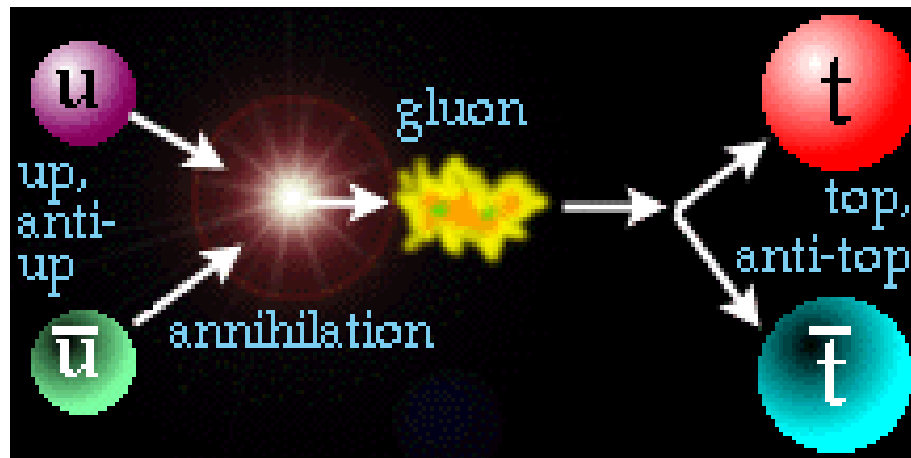

Discovered in 1995 at Fermilab

Fermilab Tevatron Collider

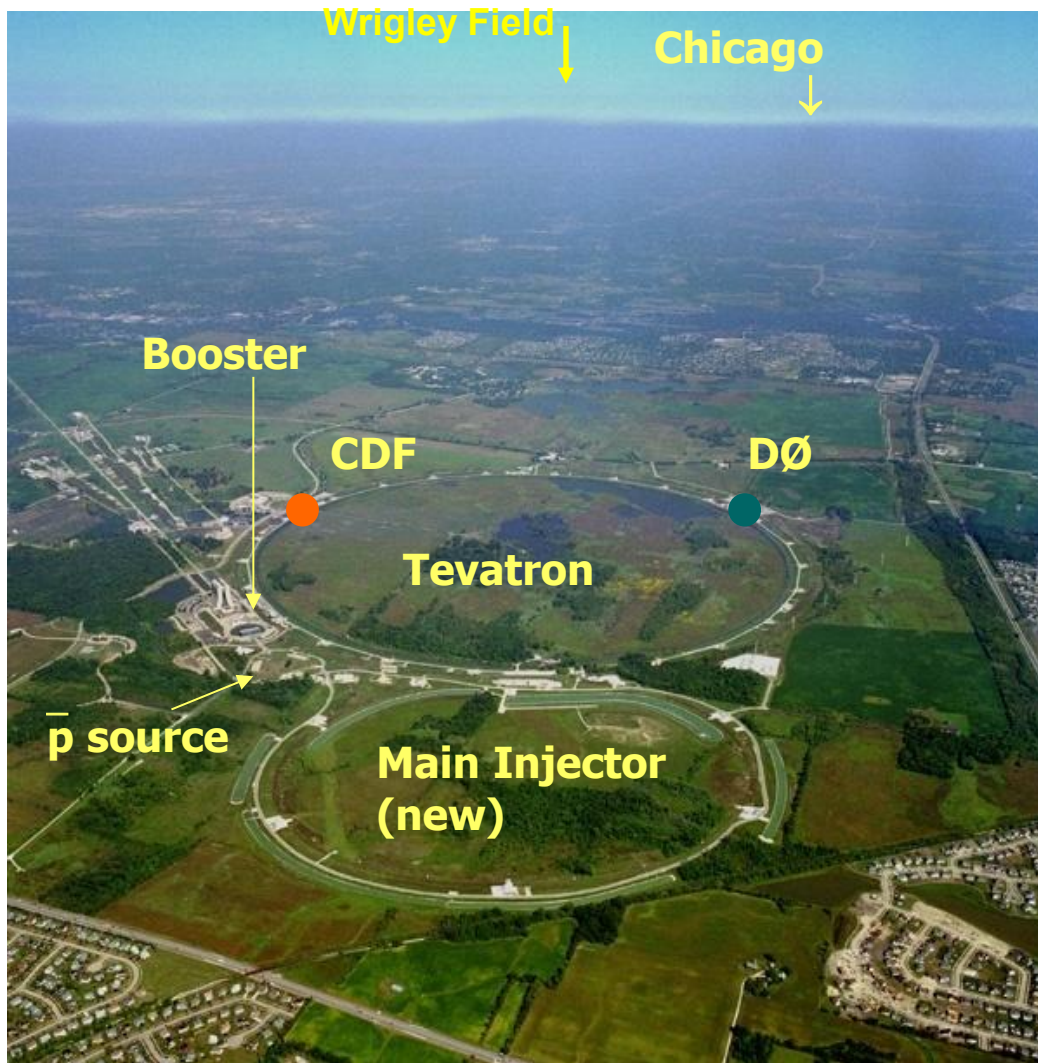

- Collide **protons and anti-protons** at CDF and DØ
- Total energy is 1.96×10^{12} eV
- Circumference is **6.28 km**
- **Top quark was discovered here in 1995**
- **Tau neutrino was discovered here in 2000**

“Beam me up Scotty!”

■ "Antimatter?" "Pure energy?"

What is this, *Star Trek*?

- The idea of antimatter is strange, made all the stranger because the universe appears to be composed entirely of matter. Antimatter seems to go against everything you know about the universe.
 - What happens if you put anti-coffee into a coffee cup?
If antimatter and matter are exactly equal, but opposite in electric charge, then why is there so much more matter in the universe than antimatter?

This is one of the “million dollar questions!”

Matter and Anti-Matter

Where did anti-matter go?

Matter and Anti-Matter in Early Universe

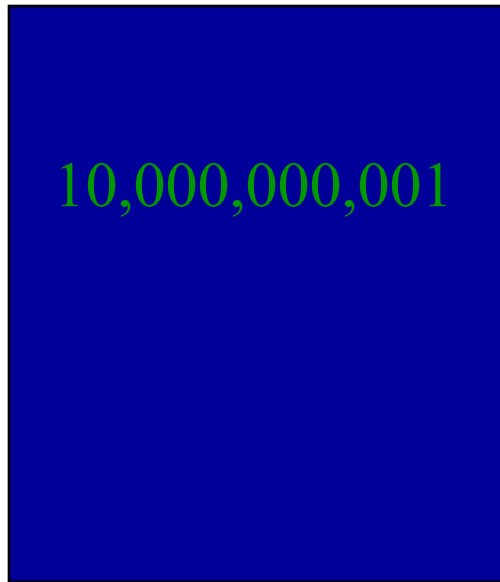

Matter

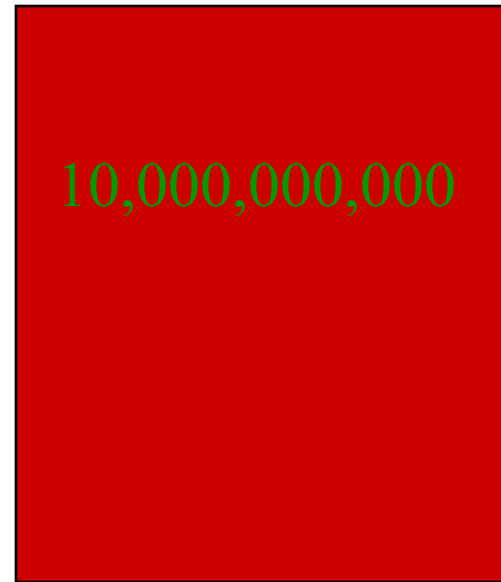

Anti-matter

Matter and Anti-Matter in Current Universe

is

1

Matter

Anti-matter

The Great Annihilation



*I think I finally
understand atoms*

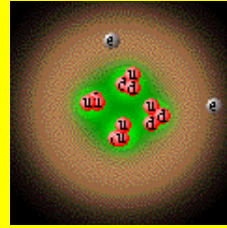

Nothing lasts for ever

The (free) neutron is radioactive and decays after 15 minutes into proton, electron and “neutrino” (electron-like neutral particle)

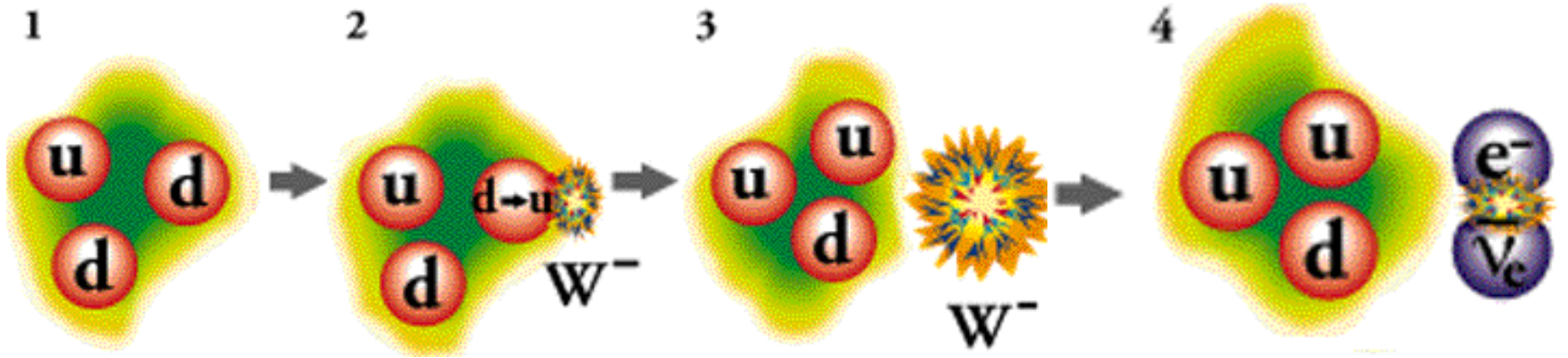

This decay process is very weak (15 minutes is an eternity!) Without such weak interactions the Sun would not shine!

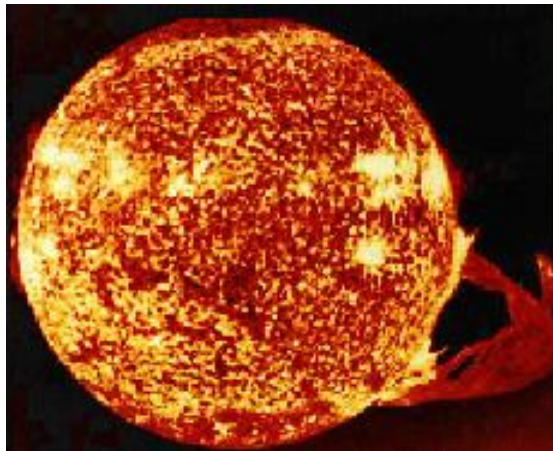

The Weak Force

- At the quark level, a down quark in the neutron decays into an up quark, by emitting a W boson.
- The heavy W boson is the carrier of the weak force.
- Since the W is very heavy (more than 80 times the proton itself), it takes a long time for quantum fluctuations to gather the where-with-all to support the decay. Thus a “weak” decay.
- Finally the W itself decays into leptons

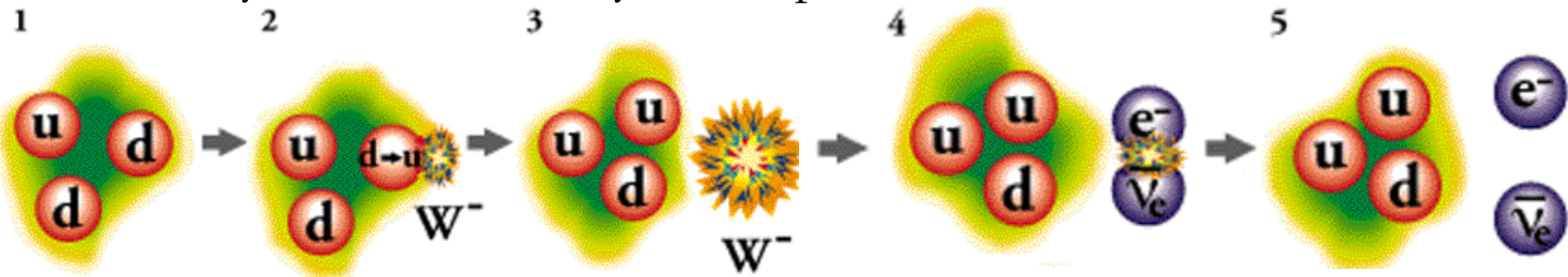

Neutrinos from the Sun

Question: How many neutrinos from the Sun are passing through your fingernail in one second?

Answer: 40 billion! – day and night since neutrinos can pass right through the Earth without interacting

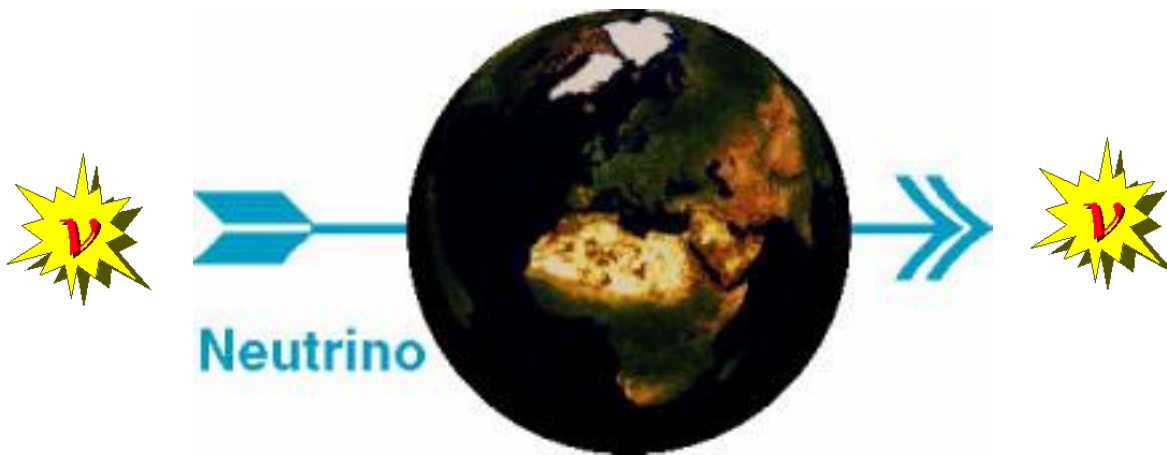

(1956 Cowan, Reines)
predicted by Pauli, 1933

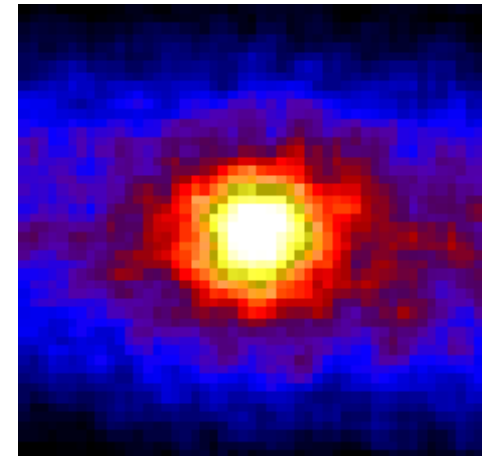
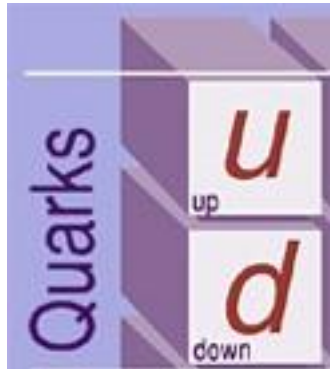

Photo of Sun taken
underground using
neutrinos

W particles – the left-handed alchemists



W^-

Just like rifle bullets, quarks and leptons spin as they whizz along

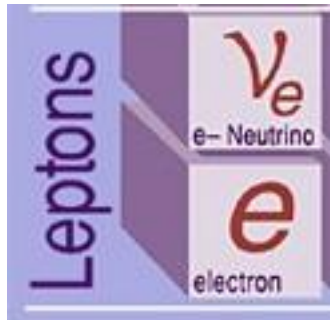

W^+

The quarks and leptons can only see W particles if they spin to the left!

This shatters mirror symmetry!

(Lee and Yang, Nobel prize 1957)

Electroweak theory predicted a heavy version of the photon called Z^0 which was discovered in 1983 (Rubbia, van der Meer)

Until now, we know

- The Elementary Constituents of Matter.

AND

- The forces that control their behaviour at the most basic level.



Interactions

Four forces in Nature

1 Gravity



Newton

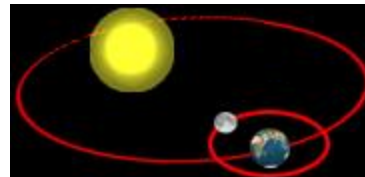

2 Electromagnetism



Faraday



3 Weak Interaction

Beta (radioactive) decay

Muon decay

Time scales: $10^{-12} \sim 10^3$ sec



4 Strong Interaction

Hold nuclei together

Particle collision

Time scales: 10^{-23} sec

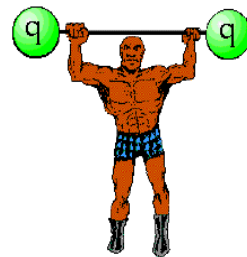

Quarks

- Elementary particle (a point-like particle; can be much heavier than a composite particle, such as proton; e.g., top quark mass is 173 times of proton mass.)
- Involved in strong, weak and electromagnetic interactions

Leptons

- Elementary particle (a point-like particle)
- Not involved in strong interaction

Quarks and Leptons

Quarks	u up	c charm	t top
	d down	s strange	b bottom
Leptons	ν_e e- Neutrino	ν_μ μ - Neutrino	ν_τ τ - Neutrino
	e electron	μ muon	τ tau
	I	II	III
The Generations of Matter			



Why 3 families?

The introduction of electron neutrino

- The (electron) neutrino was postulated first by Pauli in 1930 to explain how beta decay could conserve energy, momentum, and angular momentum (spin).
- In contrast to Bohr, who proposed a statistical version of the conservation laws to explain the observed continuous energy spectra in beta decay.
- Fermi named this "little neutral one" particle as neutrino.

Electron and its neutrino

The **electron** was discovered in 1897, by **Joseph Thomson**.

The electron's anti-particle, **positron**, was predicted by **Paul Dirac** in 1928, and discovered by **Carl Anderson** in 1932.

From Zhi-zhong Xing's Neutrino physics lectures



In 1956 **Clyde Cowan** and **Frederick Reines** discovered the positron's partner, **electron antineutrino**.

Muon

The **muon** particle, a sister of the electron, was discovered in 1936 by **Carl Anderson** and his first student **S. Neddermeyer**; and independently by **J. Street *et al.***

It was not **Hideki Yukawa's** "pion". And it was the first flavor puzzle.

Isidor Rabi famously asked:
Who ordered that?



Isidor Isaac Rabi



FAMILY

Muon neutrino

The **muon neutrino**, the muon's neutral counterpart, was discovered by **Leon Lederman**, **Melvin Schwartz** and **Jack Steinberger** in 1962.

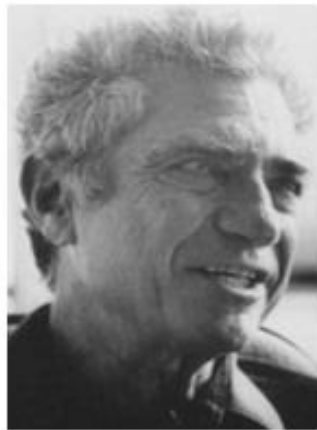

Neutrino flavor conversion was proposed by **Z. Maki**, **M. Nakagawa** and **S. Sakata** in 1962.



Neutrinos convert into **antineutrinos** first proposed by **Bruno Pontecorvo** in 1957.



Tau and its neutrino

The **tau** particle was discovered by **Martin Perl** in 1975 via:

$$e^+ + e^- \rightarrow e^\pm + \mu^\mp + \text{undetected particles}$$

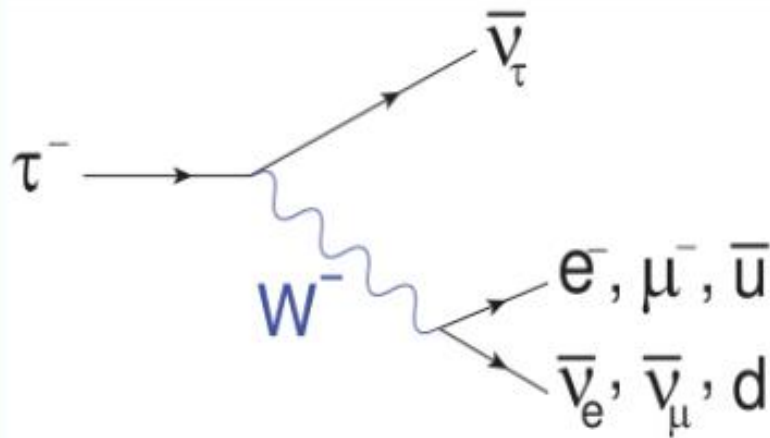

In 2000, the **tau neutrino** was finally discovered at the Fermilab.

The lepton family is complete!

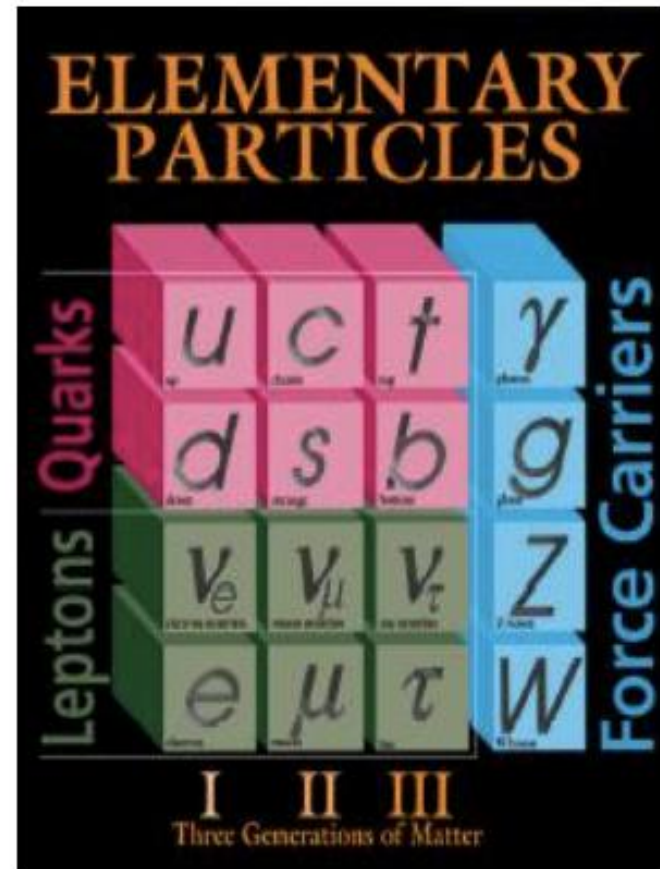

Leptons and Nobel Prizes

e	J.J. Thomson 1897 😊	J.J. Thomson 1906 (NP)
ν_e	C.L. Cowan et al. 1956	F.J. Reines 1995 (NP)
μ	J.C. Street et al. C.D. Anderson 1936 😊	1975 – 1936 = 1936 – 1897 = 39
ν_μ	G. Danby et al. 1962	M. Schwartz, L.M. Lederman, J. Steinberger 1988 (NP)
τ	M.L. Perl et al. 1975 😊	M.L. Perl 1995 (NP)
ν_τ	K. Kodama et al. 2000	

Antimatter: Positron.

Predicted by P.A.M. Dirac in 1928.

Discovered by C.D. Anderson in 1932; Nobel Prize in 1936.

Neutrino Oscillations (2015 Nobel Prize)

Due to neutrino masses, whose generation mechanism is sensitive to New Physics.



Takaaki Kajita

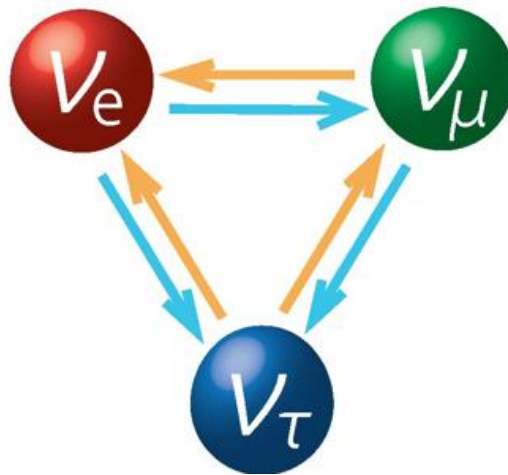

Arthur B. McDonald

(In 1968, neutrino masses were assumed to be zero.)

The Weak Force

The Weak Force

- Parity Violation

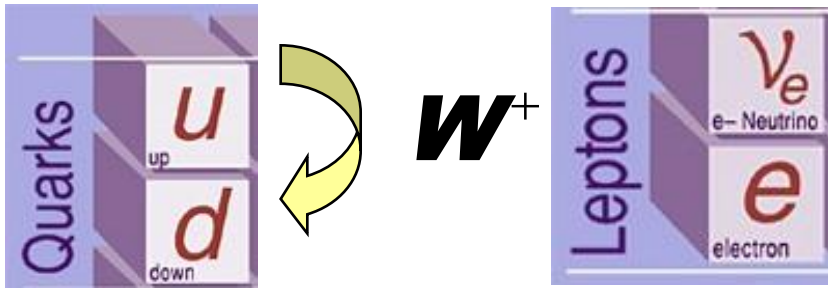

(Lee and Yang, Nobel prize 1957)

Chien-Shiung Wu

- The unified weak and electromagnetic interaction
(Glashow, Salam and Weinberg, Nobel prize 1979)



The Sun and the W boson mass

- The Sun is powered by the **nuclear fusion**

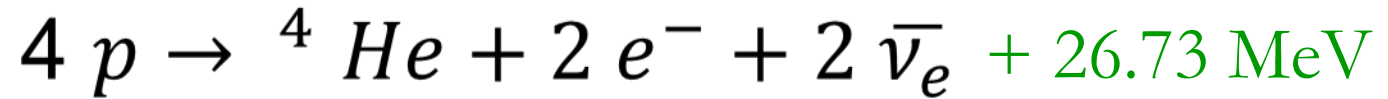

- It's a **Weak interaction** – carried by the **W boson**.
- The Sun can shine for billions of years – it's because W boson is heavy, about 80 times of proton mass.
- **Why is the W boson so heavy?**



Higgs mechanism

Brout-Englert-Higgs Mechanism

(Generate mass for W and Z Bosons)

- Spontaneously broken symmetry



Nambu (Nobel Prize 2008)

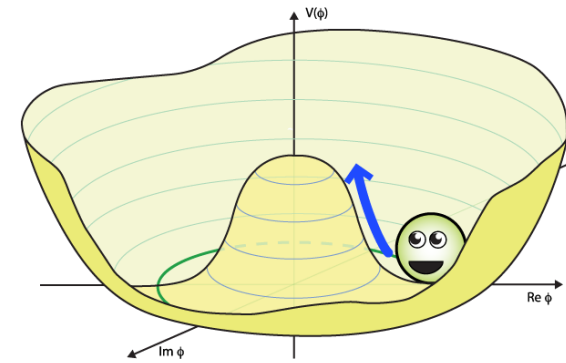
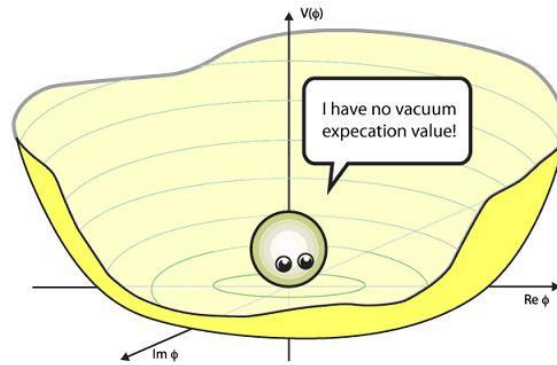

- Brout-Englert-Higgs Mechanism (1964)



Brout



Englert



Peter Higgs

Englert, Higgs
2013 Nobel Prize

W and Z boson masses

- W and Z boson masses **were predicted** by the Standard Model of particle physics to be about 80 and 91 GeV in 1968
- They were **discovered in 1983** at CERN.
- Nobel prizes, **Rubbia** and **van der Meer**, 1984.



How do they gain Mass?

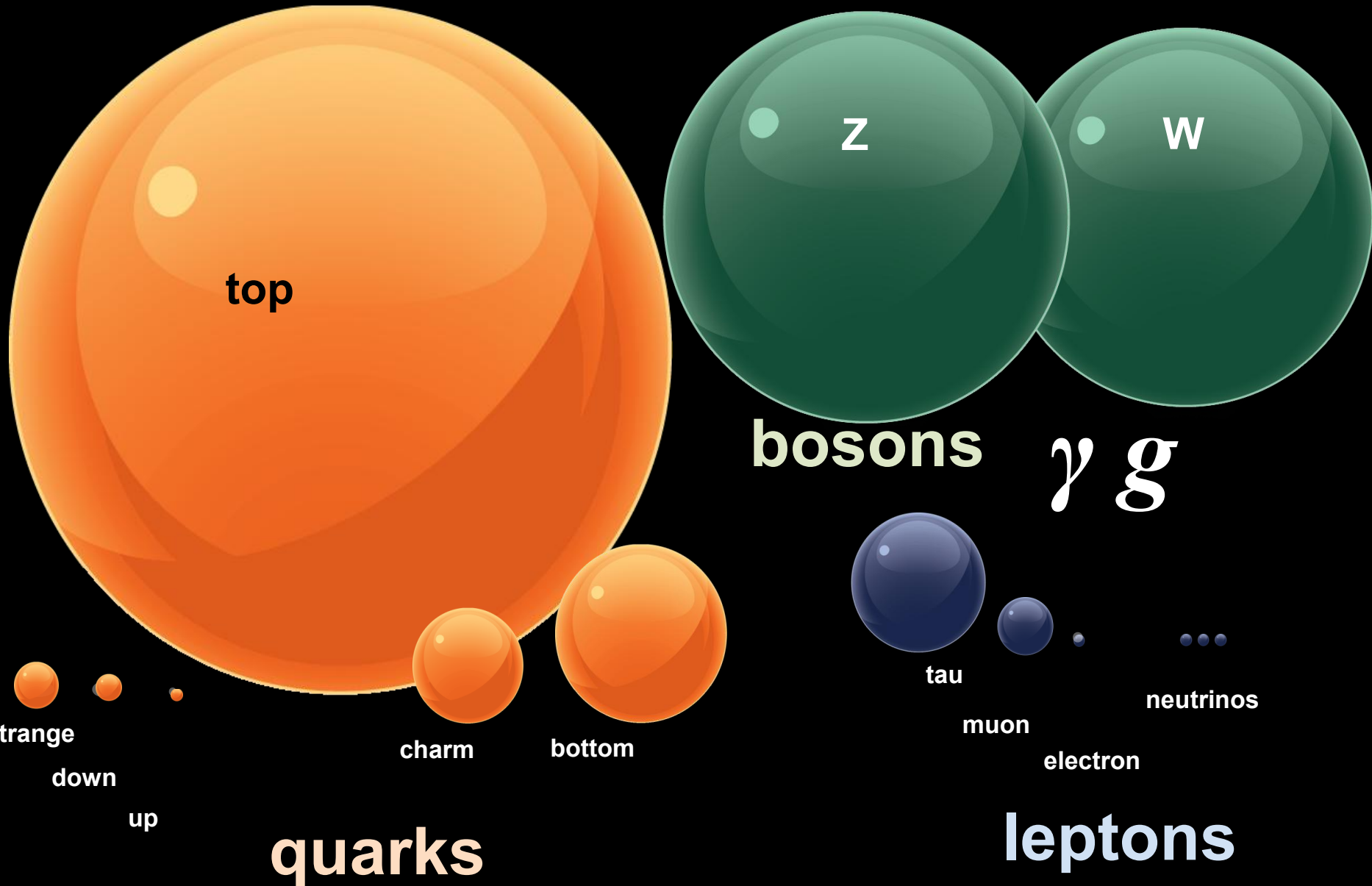

Higgs Boson generate the mass of ALL massive particles in the Standard Model.

- W and Z gauge bosons
- Higgs boson
- All (Dirac) Fermions: 6 quarks and 6 leptons
- If neutrinos are found to be their own anti-particles, i.e. Majorana fermions,



New Physics beyond the Standard Model
is required.

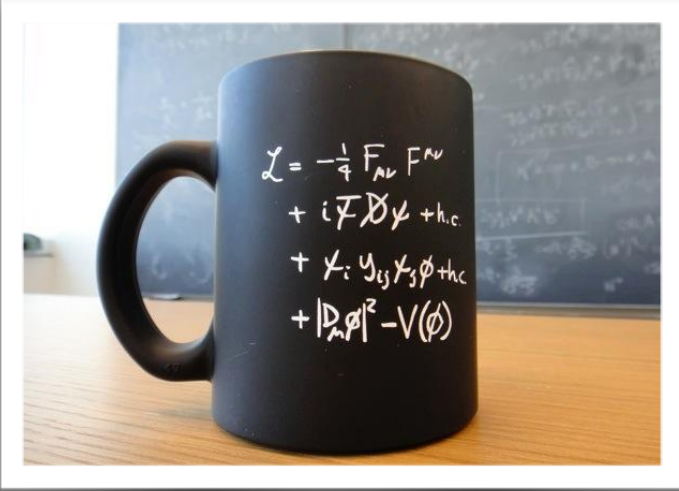

Gauge principles



Higgs Mechanism



Standard Model

The Higgs Boson

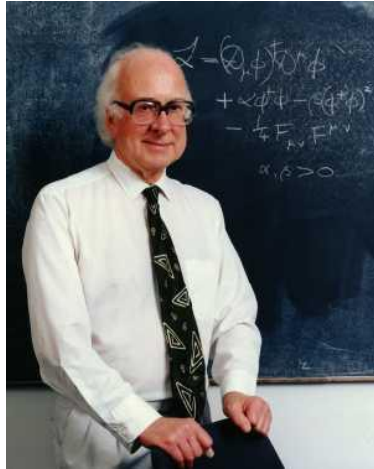

In the “Standard Model” the origin of mass is addressed using a mechanism named after the British physicist Peter Higgs.

This predicts a new particle: the Higgs boson.

What is the Higgs boson? In 1993, the then UK Science Minister, William Waldegrave, issued a challenge to physicists to answer the questions 'What is the Higgs boson, and why do we want to find it?' on one side of a single sheet of paper. This cartoon is based on David Millar's winning entry.



The Search for the Higgs Boson

1967: The Standard Model was born

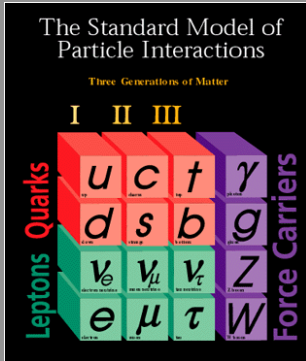

2001: Fermilab Tevatron



2012: Something was discovered!

1964: Higgs boson was hypothesized

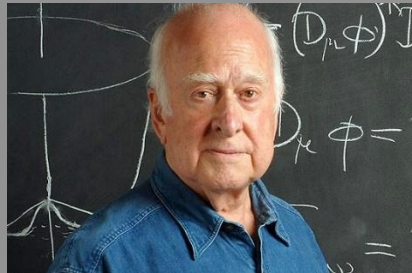

1989: Large Electron-Positron Collider



2010: The Large Hadron Collider started taking data



On
Mass
Resonances



$$m = \frac{E}{c^2}$$



$$m = \frac{E}{c^2}$$



$$m = \frac{E}{c^2}$$



$$m = \frac{E}{c^2}$$

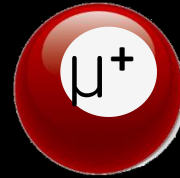

$H \rightarrow$
 $Z^0 (\rightarrow \mu^- \mu^+)$
 $Z^0 (\rightarrow e^- e^+)$



Frequency

Continuum
production

Mass Resonance

M_H
↓

Invariant Mass

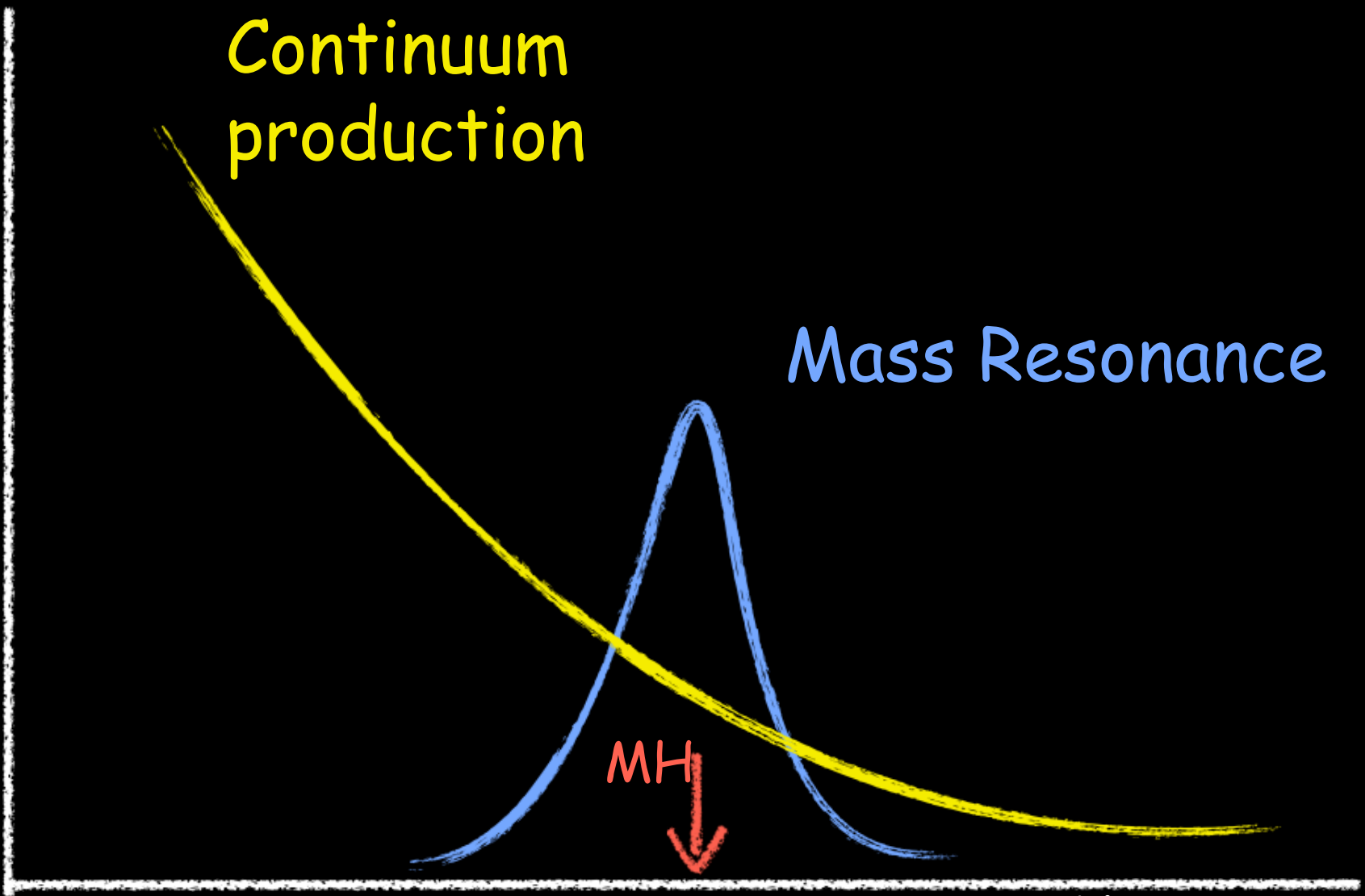

A Cultural Reaction!

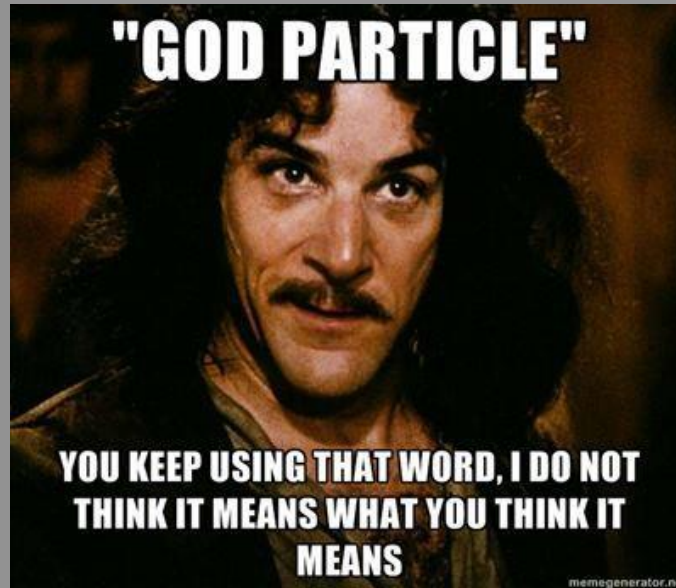
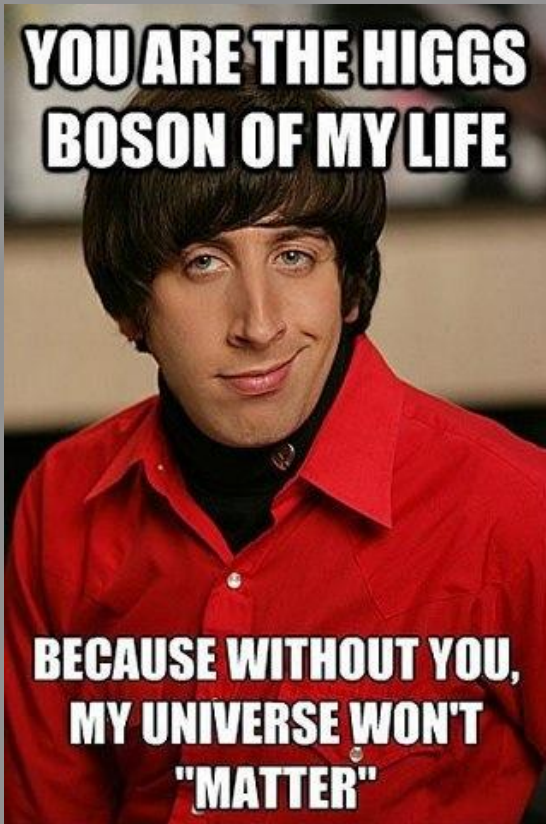

The Standard Model of Elementary Particle Physics

Simplicity and Beauty of The Standard Model

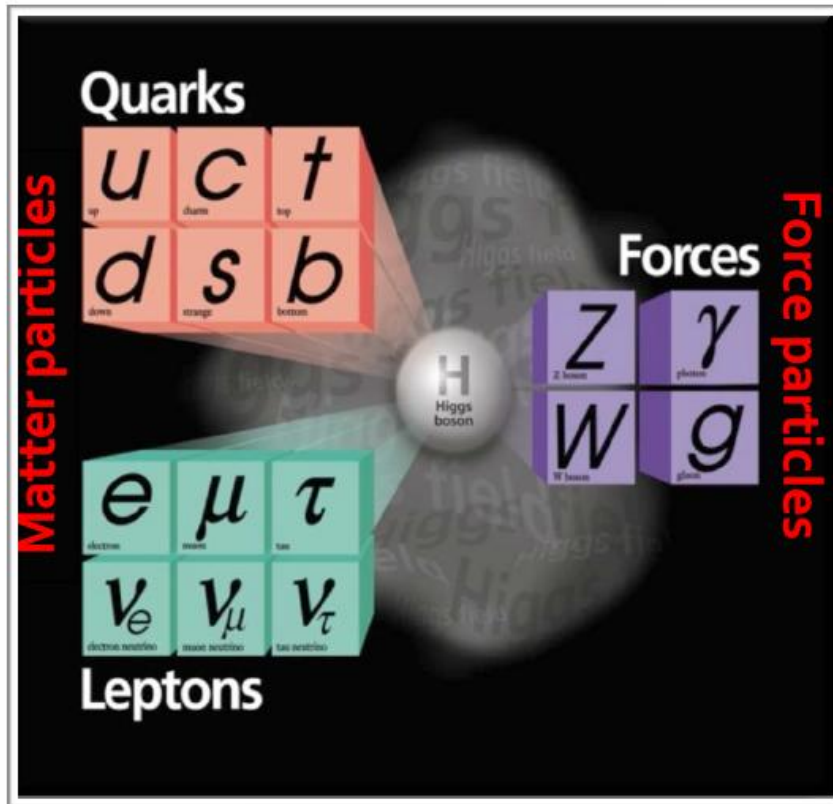





Periodic Table of Elementary Particles

$$\begin{aligned} \mathcal{L} = & -1/4 F_{\mu\nu} F^{\mu\nu} \\ & + i\bar{\Psi} \not{D} \Psi + h.c. \\ & + \Psi_i \gamma_{ij} \Psi_j \Phi + h.c. \\ & + |D_\mu \Phi|^2 - V(\Phi) \end{aligned}$$

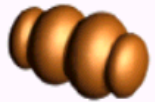
SM Lagrangian

The Standard Model of Particle Physics

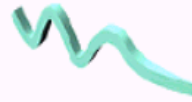
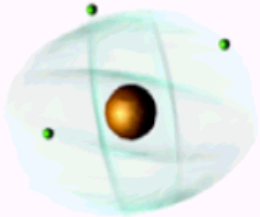
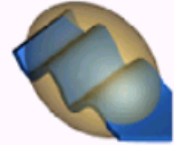
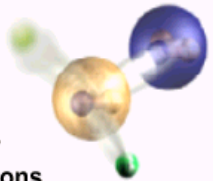
Strong	Electromagnetic	Weak
<p>Glueons (8)</p>  <p>Quarks</p>  <p>Mesons Baryons</p>  <p>Nuclei</p> 	<p>Photon</p>  <p>Atoms Light Chemistry Electronics</p> 	<p>Bosons (W,Z)</p>  <p>Neutron decay Beta radioactivity Neutrino interactions Burning of the sun</p> 

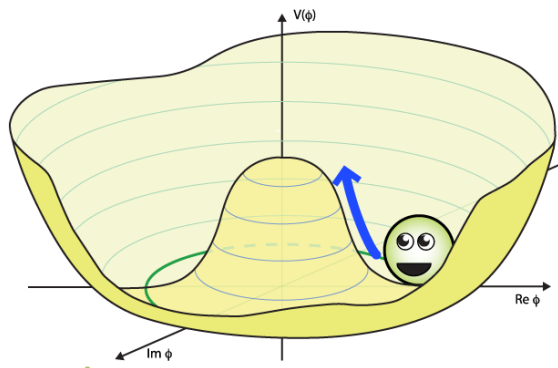
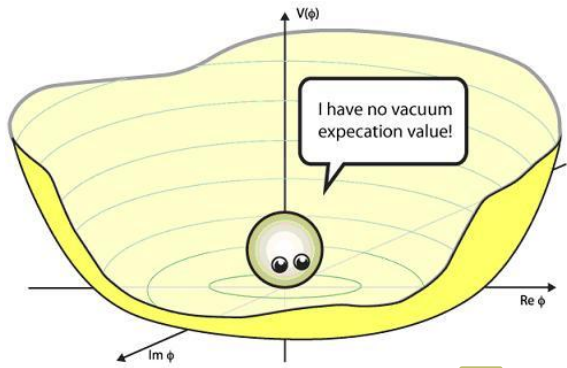

Brout-Englert-Higgs Mechanism

Importance of Higgs mass generation

- $m_u \sim 2.2$ MeV, and $m_d \sim 4.7$ MeV; generated by Higgs mechanism.
- If $m_u = m_d$, and assume the proton were electrically charged neutral, then $m_p = m_n$, because proton (and neutron) mass (about 940 MeV) is dominated by QCD interaction to bound quarks together.
- If $m_u = m_d$, then $m_p > m_n$, because proton is electrically charged.
 Our universe (including us) will not exist.
- $m_n - m_p \sim 1.3$ MeV is crucial to the formation of all elements in the periodic table.

Importance of Higgs mass generation

- If electron mass were not 0.511 MeV, the energy levels of Hydrogen atom (in Bohr model) will not be

$$E_n = \frac{-13.6 \text{ eV}}{n^2}$$

 Photosynthesis will not occur, and we will not exist.

- Or, it would be a completely different universe.

Shape of the Standard Model

Classical Mechanics

- angular momentum $\gg \hbar$
- speed $\ll c$

Quantum Mechanics

- any angular momentum
- speed $\ll c$

Special Relativity

- angular momentum $\gg \hbar$
- any speed

Quantum field theory

- any angular momentum
- any speed

Standard Model

- local quantum gauge theory
- $SU(3)_C \otimes SU(2)_W \otimes U(1)_Y$
- valid down to $\sim 10^{-16}$ cm

The *Renormalization and Loop calculation* (Renormalizable Theory)

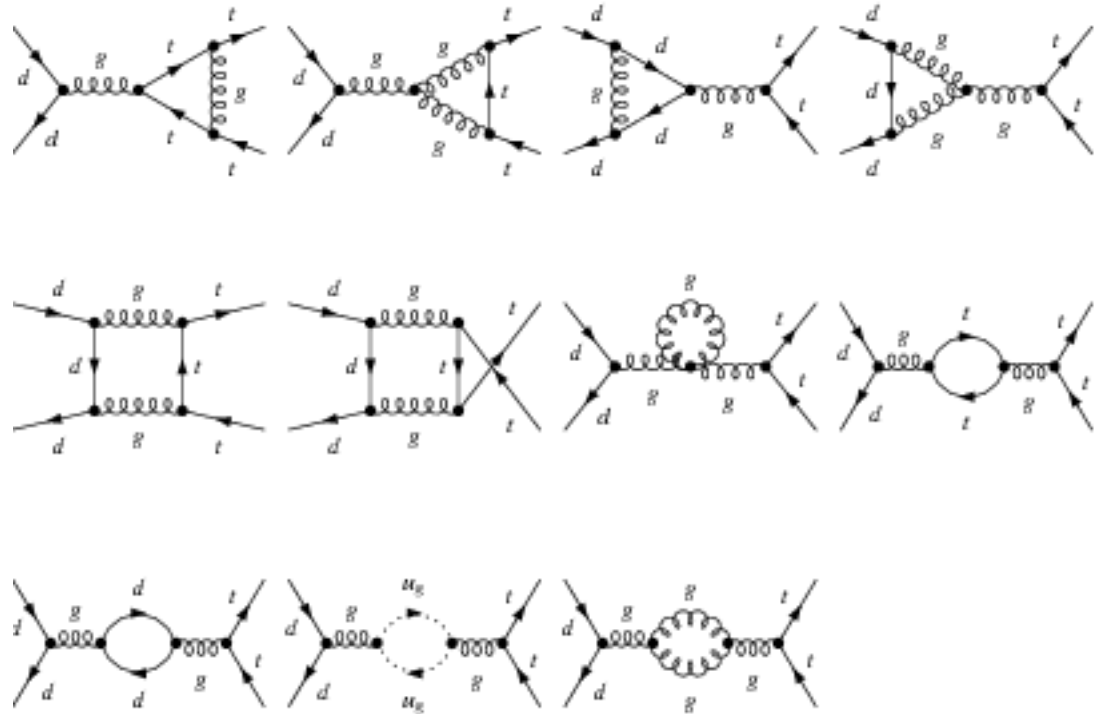





‘t Hooft, Veltman, 1999 Nobel Prize

They showed us how to perform **precision calculations** for quantum field theories in order to compare with experimental data – **to test the SM and to probe new physics**

Until now, we know

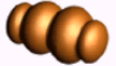
- The Elementary Constituents of Matter.
- The forces that control their behaviour at the most basic level.

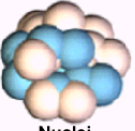
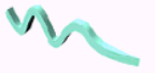
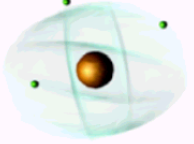
FERMIONS			matter constituents spin = 1/2, 3/2, 5/2, ...		
Leptons spin = 1/2			Quarks spin = 1/2		
Flavor	Mass GeV/c ²	Electric charge	Flavor	Approx. Mass GeV/c ²	Electric charge
ν_e electron neutrino	$<1 \times 10^{-8}$	0	u up	0.003	2/3
e electron	0.000511	-1	d down	0.006	-1/3
ν_μ muon neutrino	<0.0002	0	c charm	1.3	2/3
μ muon	0.106	-1	s strange	0.1	-1/3
ν_τ tau neutrino	<0.02	0	t top	175	2/3
τ tau	1.7771	-1	b bottom	4.3	-1/3

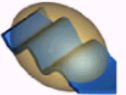
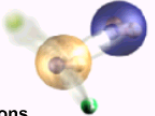
Strong	Electromagnetic
<p>Glueons (8)</p>  <p>Quarks</p>  <p>Mesons Baryons</p>  <p>Nuclei</p> 	<p>Photon</p>  <p>Atoms Light Chemistry Electronics</p> 
Gravitational	Weak
<p>Graviton ?</p>  <p>Solar system Galaxies Black holes</p> 	<p>Bosons (W,Z)</p>  <p>Neutron decay Beta radioactivity Neutrino interactions Burning of the sun</p> 

Unify the 4 fundamental forces?

History of Unification

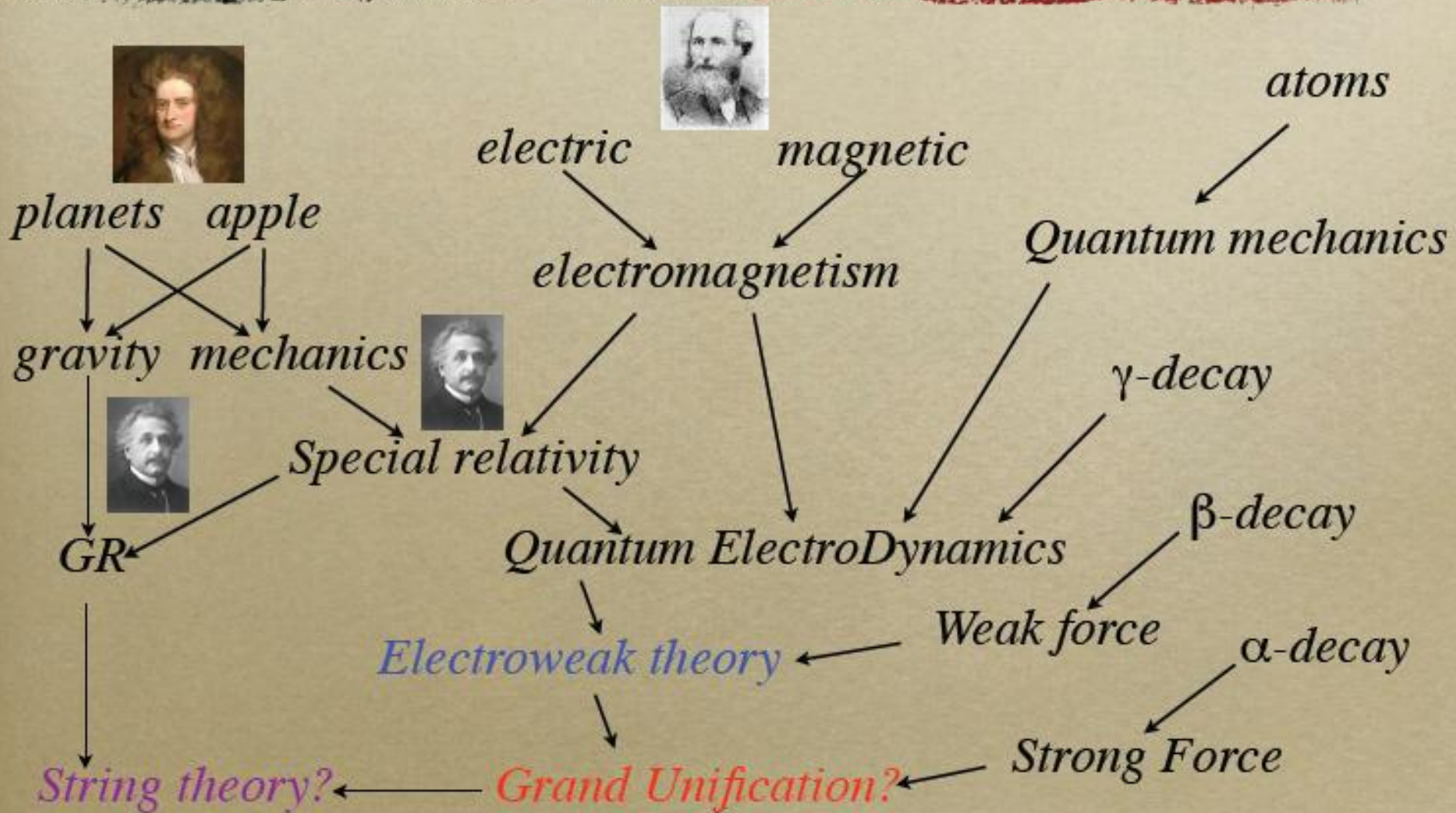



James Clerk Maxwell (~1864)

$$\vec{\nabla} \cdot \vec{\mathbf{D}} = \rho$$

$$\vec{\nabla} \cdot \vec{\mathbf{B}} = 0$$

$$\vec{\nabla} \times \vec{\mathbf{E}} = -\frac{\partial \vec{\mathbf{B}}}{\partial t}$$

$$\vec{\nabla} \times \vec{\mathbf{H}} = \vec{\mathbf{J}} + \frac{\partial \vec{\mathbf{D}}}{\partial t}$$

Modern Language

$$\square \Phi^\mu = \frac{J^\mu}{c \epsilon_0}$$

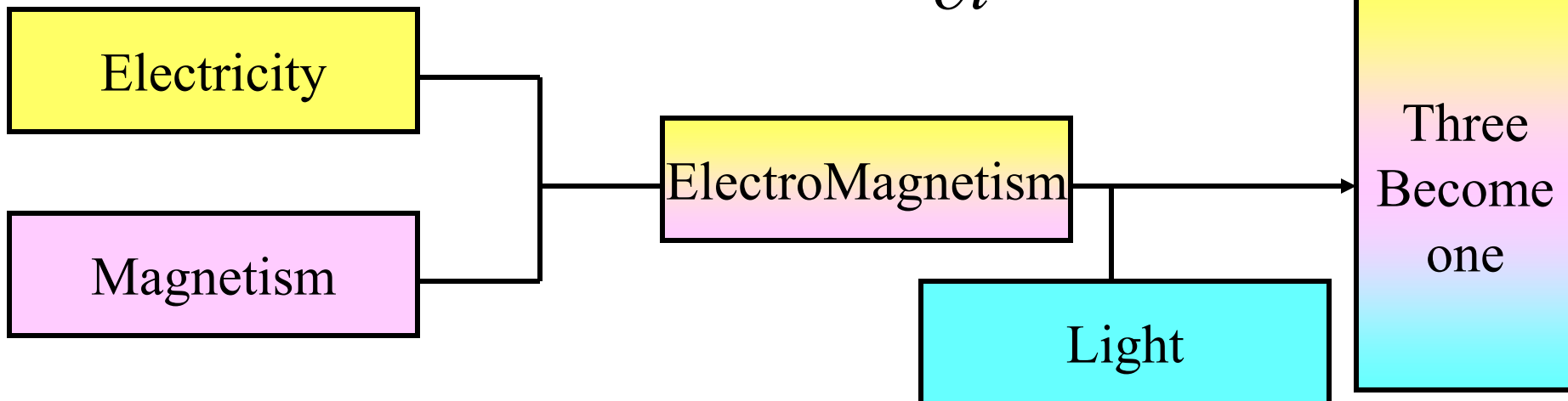

Electroweak Unification

■ Electromagnetic -

- Binds atoms together
- Long range force
- Force carrier is the photon
- Acts on charged particles

■ Weak -

- responsible for the **decay** of massive quarks and leptons into lighter quarks and leptons. i.e. nuclear decay - β -decay
- Short range force
- Force carriers are
 - W^+ , W^- and Z^0 bosons
- Acts on quarks and leptons

■ Combined into the Electroweak force

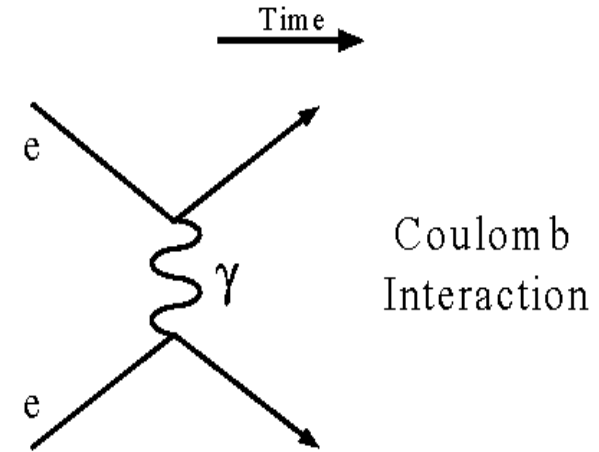
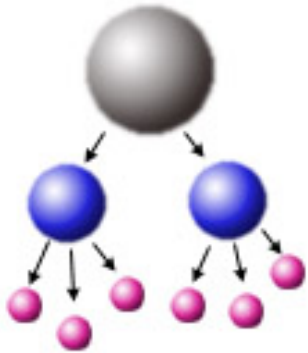
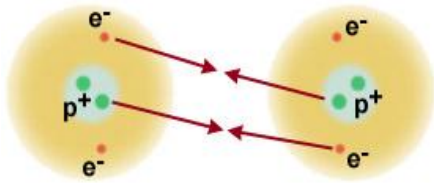

Coulomb Interaction

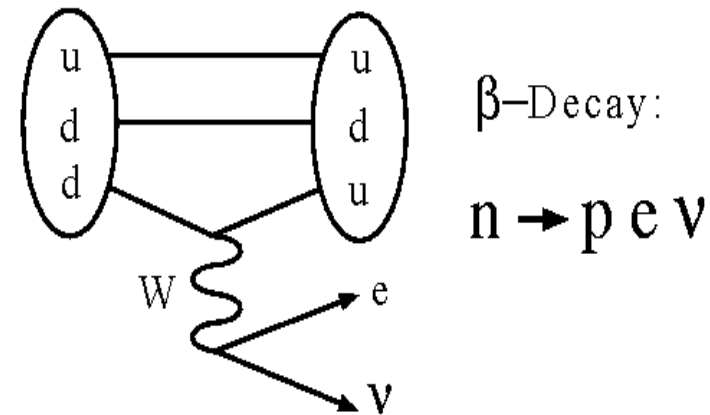

Weinberg, Glashow, Salam, 1979 Nobel Prize

The Standard Model of Particle Physics

❖ Matter fields (make up all visible matter in the universe)

▪ Fermions (Spin 1/2)

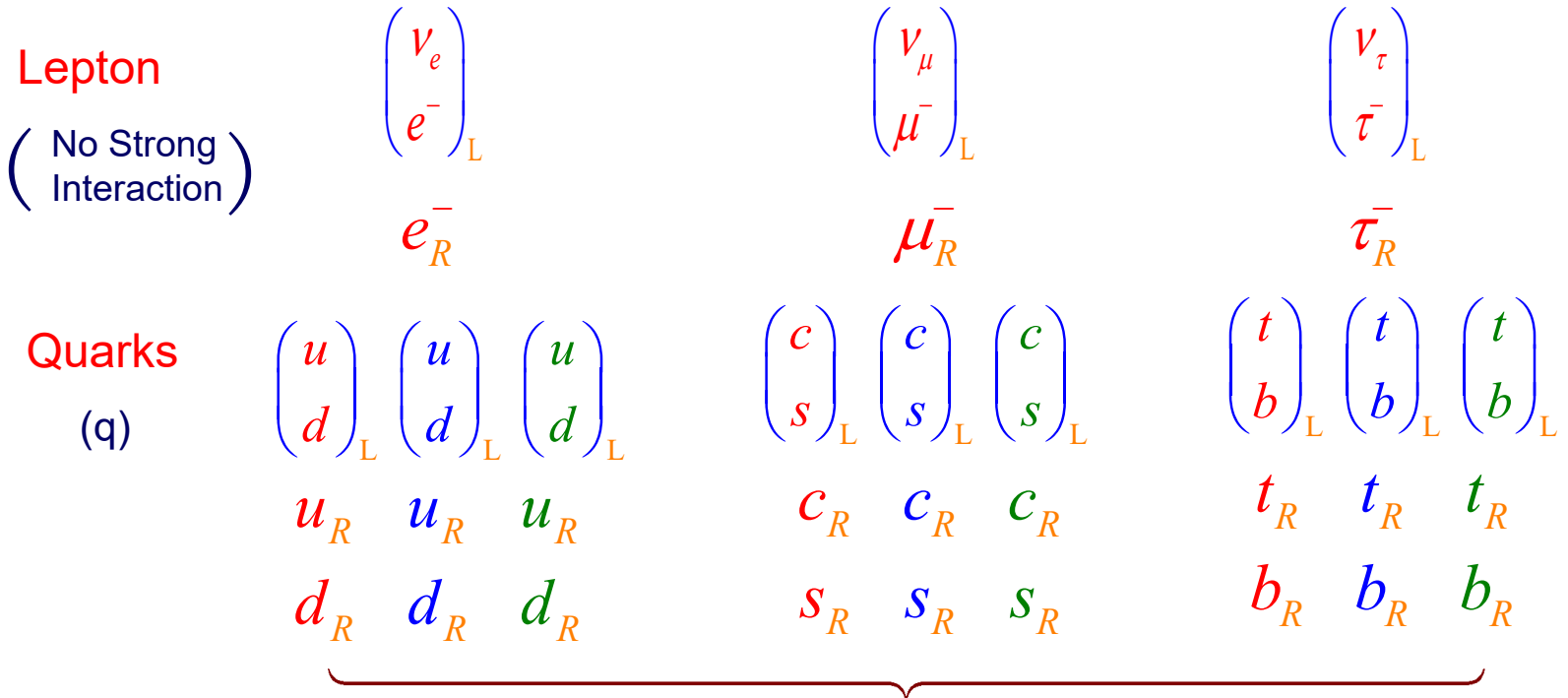

▪ Scalar (Spin 0)

3 families

Higgs Boson (July 4, 2012; Higgs or Higgs-Like Boson)
 (From **Higgs Mechanism** — Spontaneous Symmetry Breaking)

The Standard Model of Particle Physics

❖ Interactions (mediated by interchanging Gauge Bosons, spin-1 force carrier)

1) Electromagnetic Interaction (QED)

Photon (massless)

2) Strong Interaction (QCD)

Gluon (massless) (1979)

3) Weak Interaction

W^+ , W^- and Z Gauge Bosons (1983)

(massive $M_W = 80.385 \pm 0.015$ GeV
 $M_Z = 91.1875 \pm 0.0021$ GeV) 1 GeV = 10^9 eV

In SM, the Mass of W-boson, either W^\pm or Z , arises from the Higgs Mechanism

(Without it, Gauge Bosons have to be massless from gauge principle.)

Free Parameters in Standard Model

$$SU(3)_{\text{color}} \times SU(2)_{\text{Left}} \times U(1)_{\text{Hypercharge}}$$

$$\left. \begin{array}{l} g_3, g_2, g_1 \\ \lambda, \mu \end{array} \right\}$$

$$\left\{ \begin{array}{l} \alpha_S, \alpha_{\text{em}}, \theta_{\text{Weak mixing}} \\ V(\text{vacuum expectation value}) \\ m_H(\text{Higgs Boson mass}) \end{array} \right\}$$

This set can be traded by
 $\alpha_S, \alpha_{\text{em}}, G_F, m_Z, m_H$

- (3) Lepton masses
 $(e, \mu, \tau) \quad m_{\nu}'s=0$
- (6) Quark masses
 (u, d, s, c, b, t)

Mixing of quark weak eigenstates
and mass eigenstates



3 angles and 1 phase
 CP violation

(1) Strong CP phase



Total of **19** free parameters.
 So far, all experimental data agree with the prediction of **SM**.

To include neutrino masses (suggested by Neutrino Oscillation data) in the SM

- For Dirac Neutrinos



Add **3** masses and
3 mixing angles with
1 CP violation phase

- For Majorana Neutrinos



Add **3** masses and
3 mixing angles with
3 CP violation phase



The Standard Model of Particle Physics

- Mathematical model that explains the hundreds of particles and their complex interactions using:
 - 6 quarks
 - 6 leptons
 - 3 forces (Electromagnetism, Weak and Strong)
- The Standard Model is not perfect:
 - There is no Cold Dark Matter candidate.
 - We don't understand the pattern of particles masses.
 - Why are there only 3 families of quarks and leptons?
 - Do protons decay?
 - Why is there so little antimatter in the universe?
It requires CP violation. (Kobayashi, Maskawa; Nobel Prize 2008)
 - Why is gravity so weak (in particle interaction)?
- We need to go beyond the Standard Model

Different Shapes of Higgs Potential in New Physics Models

Pseudo Nambu-Goldstone Higgs

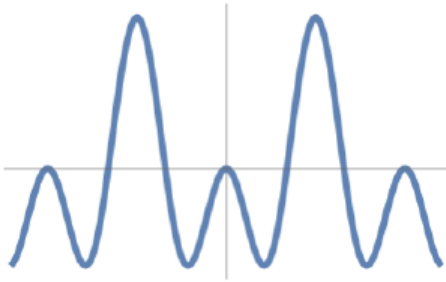

$$V(\phi) = -a \sin^2(\phi/f) + b \sin^4(\phi/f)$$

Coleman Weinberg Higgs

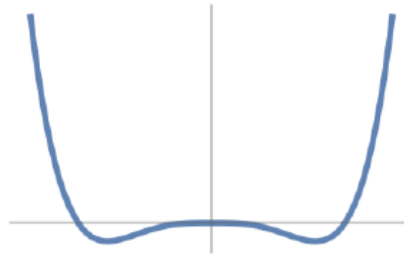

$$V(\phi) = \lambda(\phi^\dagger\phi)^2 + \epsilon(\phi^\dagger\phi)^2 \log \frac{\phi^\dagger\phi}{\mu^2}$$

Tadpole-induced Higgs



$$V(\phi) = -\mu^3 \sqrt{\phi^\dagger\phi} + m^2 \phi^\dagger\phi$$

Very different analytic Higgs behavior from SM

Landau-Ginzburg Higgs

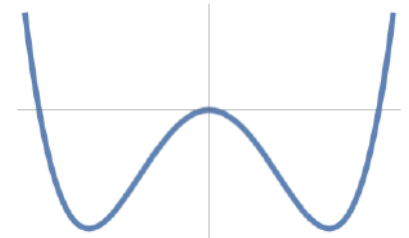

$$V(\phi) = -m^2 \phi^\dagger\phi + \lambda(\phi^\dagger\phi)^2$$

New Physics Models

(Beyond the Standard Model)

- Maxwell took a big step toward this goal when he unified electricity and magnetism, and physicists now understand that at high energies the electromagnetic and weak forces are aspects of the same force.
- To also unify strong interaction (and gravity)
 - Grand Unified Theory (GUT)
 - Supersymmetry (SUSY)
 - Extra Dimensions
 - String Theory

New Physics Models of Particle Physics

SUSY

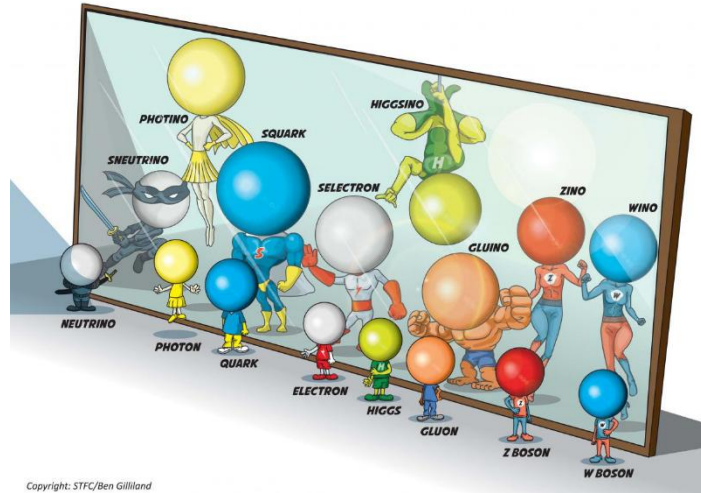

Copyright: STFC/Ben Gilliland

GUT

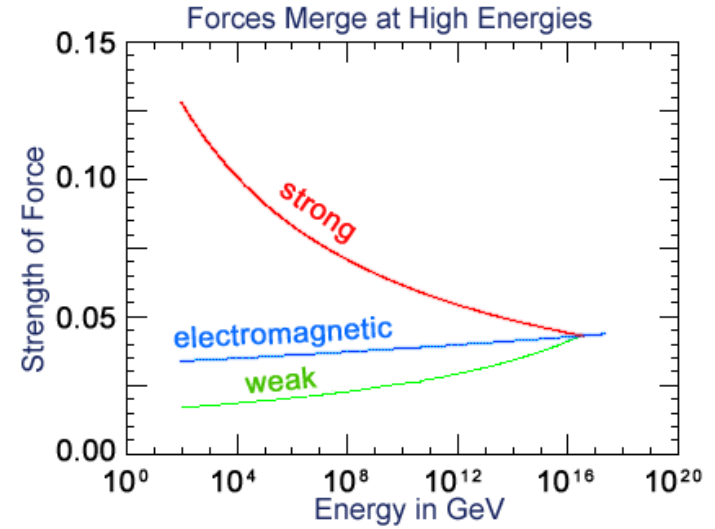

Extra dimensions

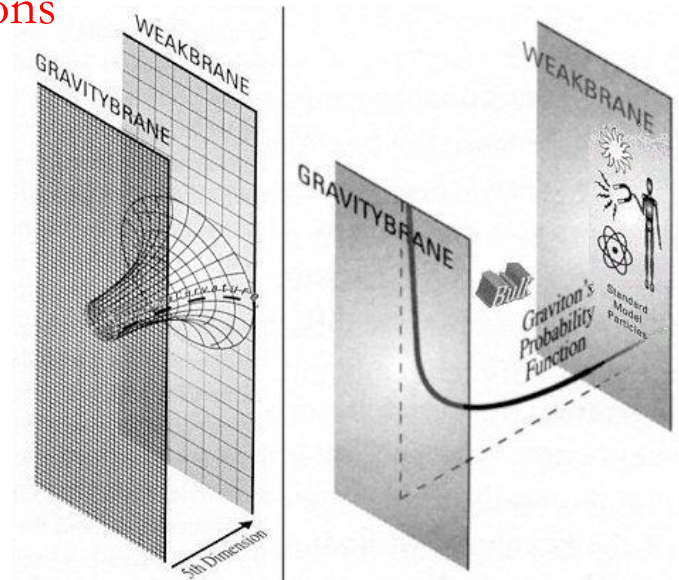
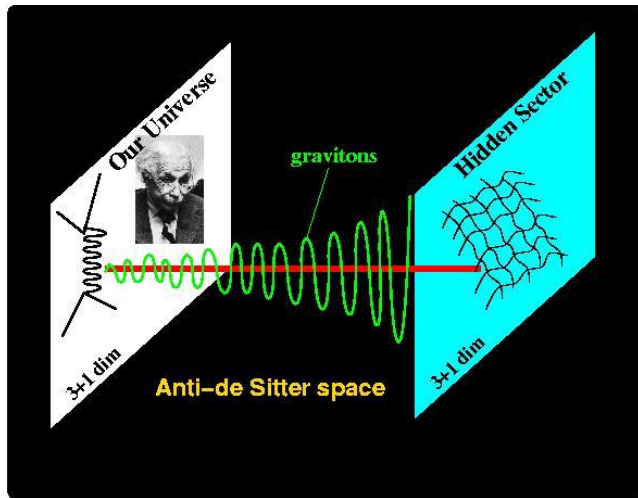

Summary

- The world is made up of quarks and leptons
- These particles interact through 4 different forces
- The Standard Model of Particle Physics works -- but is limited in what it can do.
- The Standard Model of Cosmology works – our universe is expanding with acceleration.
- We are still missing several pieces of the puzzle
- Work is underway to fill in the holes
- Mostly importantly, to find the unexpected!

Pretty cool stuff!



Thank you!

Backup Slides

The Eleven Questions Identified by the *Connecting Quarks with the Cosmos* Report

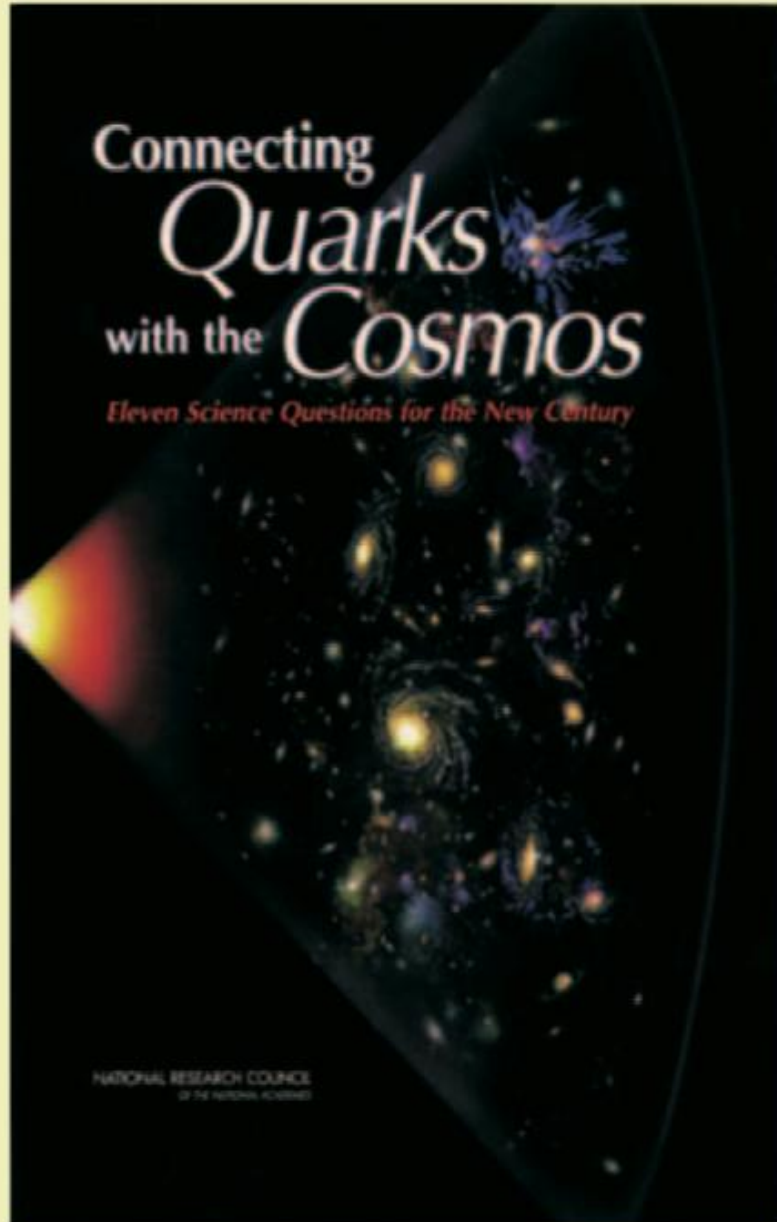

1. What is Dark Matter?
2. What is the Nature of Dark Energy?
3. How Did the Universe Begin?
4. Did Einstein Have the Last Word on Gravity?
5. What are the Masses of the Neutrinos and How Have They Shaped the Evolution of the Universe?
6. How do Cosmic Accelerators Work and What are They Accelerating?
7. Are Protons Unstable?
8. What Are the New States of Matter at Exceedingly High Density and Temperature?
9. Are There Additional Space-Time Dimensions?
10. How Were the Elements from Iron to Uranium Made?
11. Is a New Theory of Light and Matter Needed at the Highest Energies?

Evidence of Dark Matter

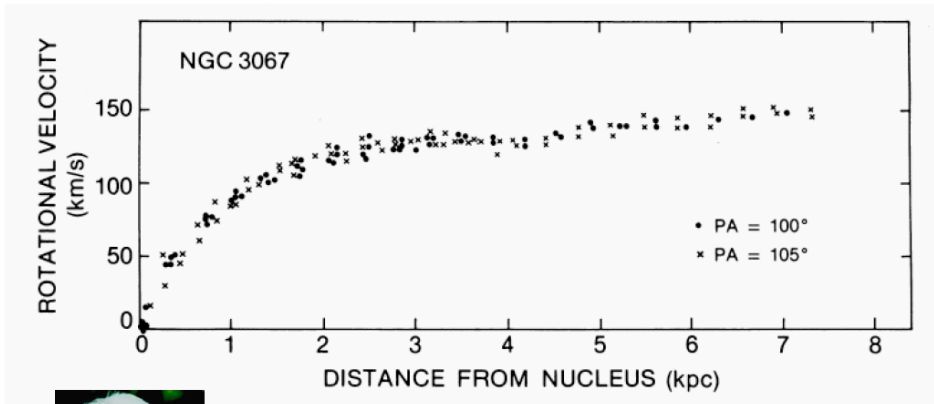

Vera Rubin

Rubin, Thonnard, Ford

“Such a velocity implies that 94% of the mass is located beyond the optical image; this mass has a ratio M/L greater than 100.”

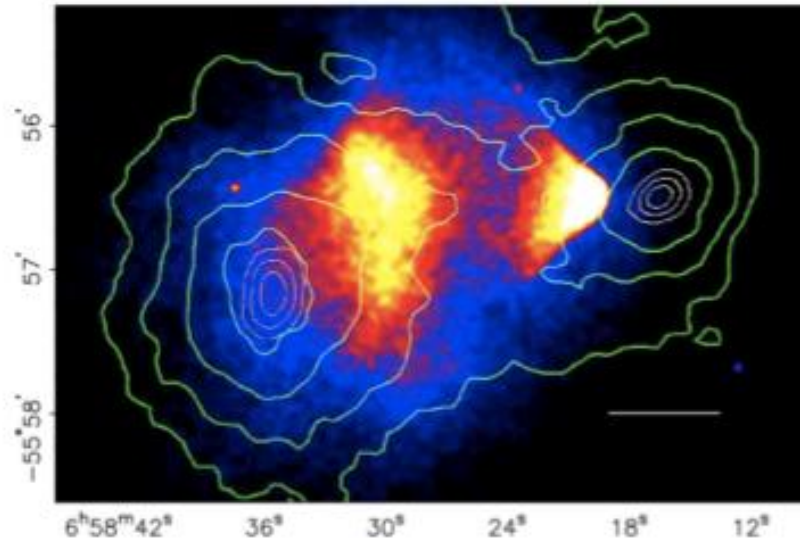
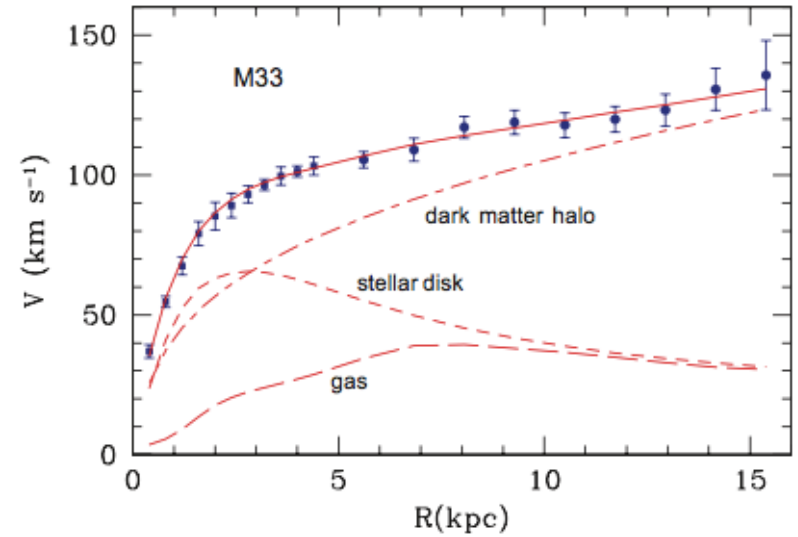

Zwicky (1933):
Dark matter is necessary to bind clusters of galaxies together (and might be detectable via gravitational lensing)

This block contains a field of galaxies on the left, a portrait of Fritz Zwicky on the right, and a text box in the middle. The text box explains that dark matter is necessary to bind clusters of galaxies together and might be detectable via gravitational lensing. The portrait shows Zwicky, an older man with a mustache, wearing a white shirt and tie, gesturing with his hand.

Exercise

- Exercise: How can we use knowledge of velocities to find the mass of the galaxy?



$$v \sim \frac{1}{\sqrt{R}}$$

- This is the same as Kepler's 3rd law, which can be derived from Newton's laws:
- $F = ma = G mM/R^2$; So $a = G M/R^2$;
- Also $a = v^2/R$, so $v^2 = G M/R$
- Assuming the mass does not change with R , i.e., all the mass is well inside the radii R being considered, then the velocity can be used to find the mass, and the velocity is expected to decrease as $1/\text{sqrt}(R)$

This is not what's found experimentally.



Dark Matter

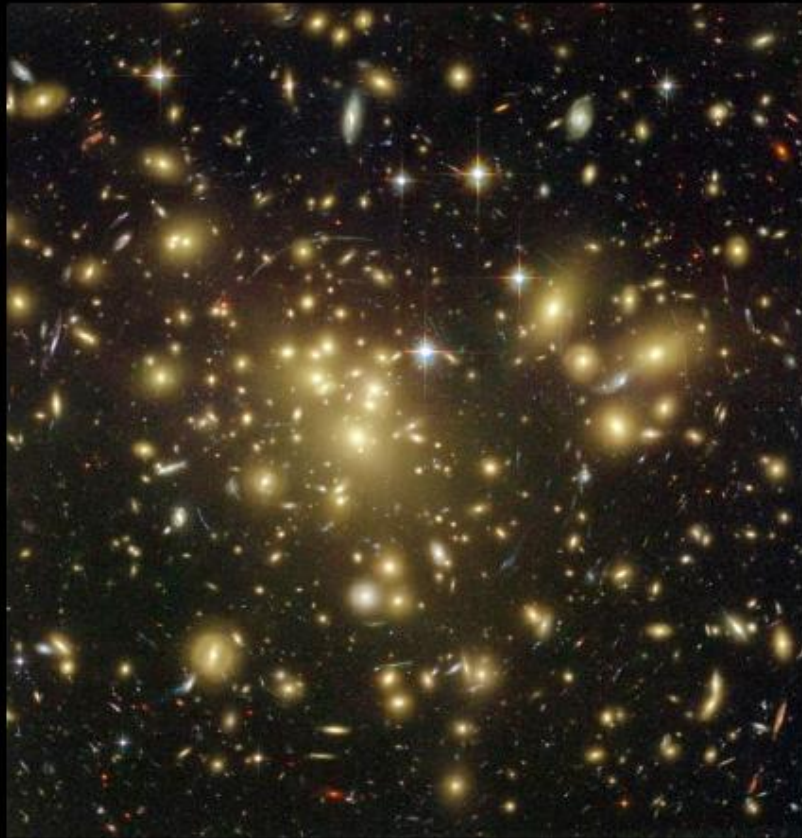

Zwicky (1933):

Dark matter is necessary to bind clusters of galaxies together (and might be detectable via gravitational lensing)

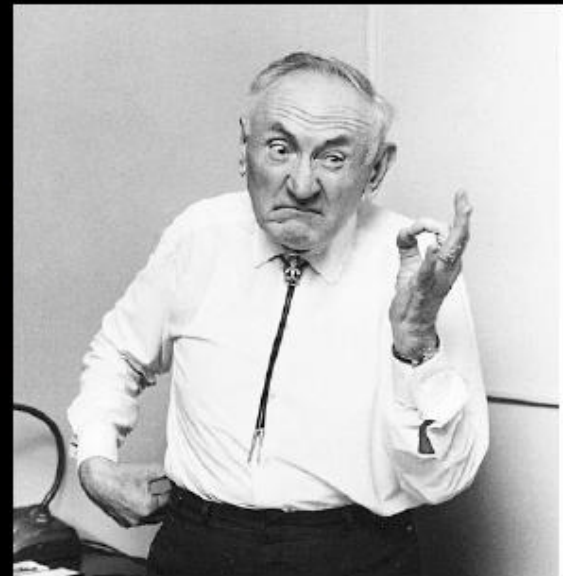

How to probe Dark Matter?

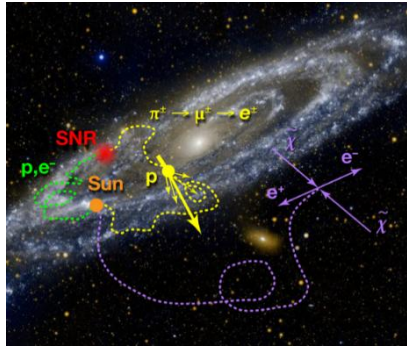

Indirect search

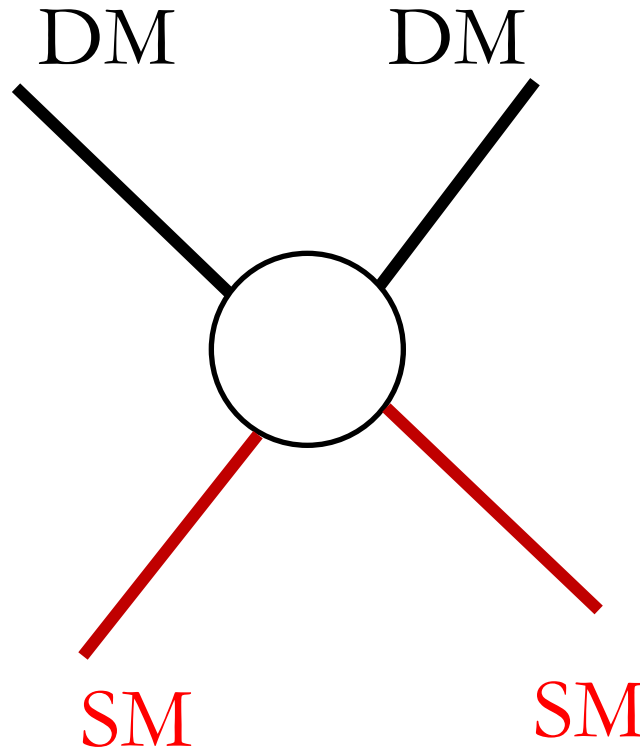
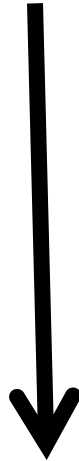

Collider search

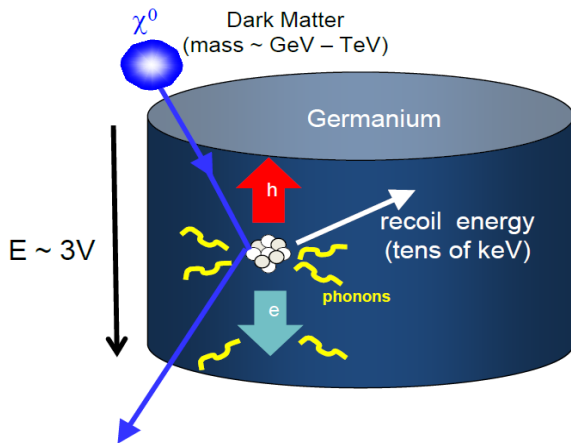

Direct search



Modern Cosmology

- About 13.8 billion years ago, the universe was in an extremely hot, dense state and began expanding.
- Space itself expanded, and all matter (including Dark Matter) and energy were once much closer together.

=>

Big Bang Theory

- In the intervening years, the universe has been expanding, cooling as it goes.

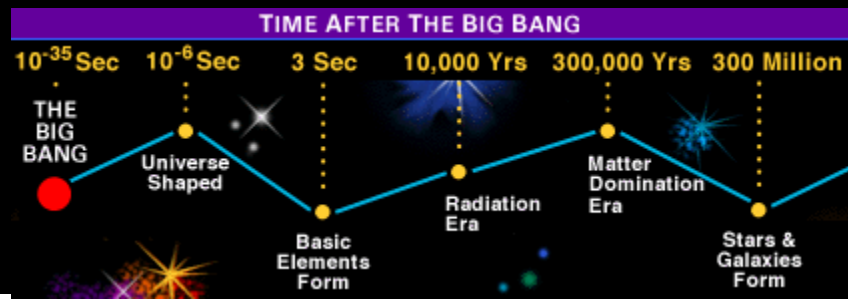

Modern Cosmology

- *Big Bang Theory*
 - *2011 Nobel Prize for discovering the accelerating expansion of the Universe through observations of distant supernovae.*
- => Dark Energy*



Saul Perlmutter, Brian P. Schmidt, Adam G. Riess, 2011 Nobel Prize

- In the intervening years, the universe has been expanding, cooling as it goes.

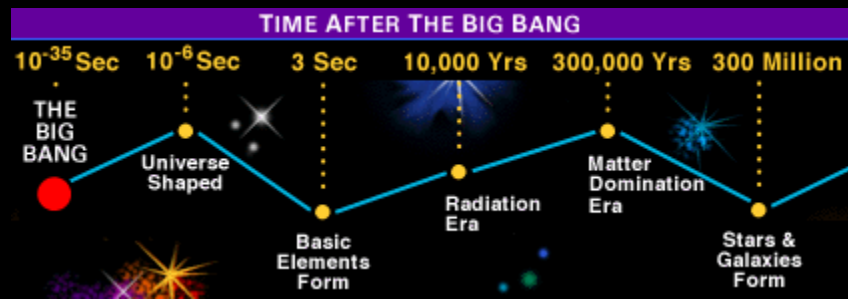



Einstein (1916):

Gravity arises from
curvature of spacetime

$$G_{ij} = 8\pi T_{ij} - \Lambda g_{ij}$$

LIGO detector and Gravitational waves (2017 Nobel Prize)

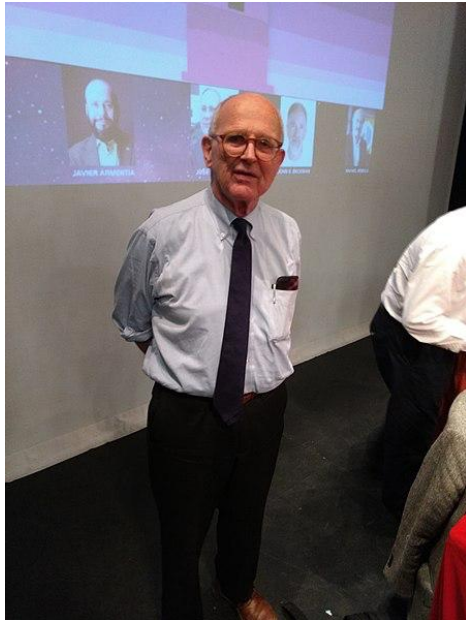
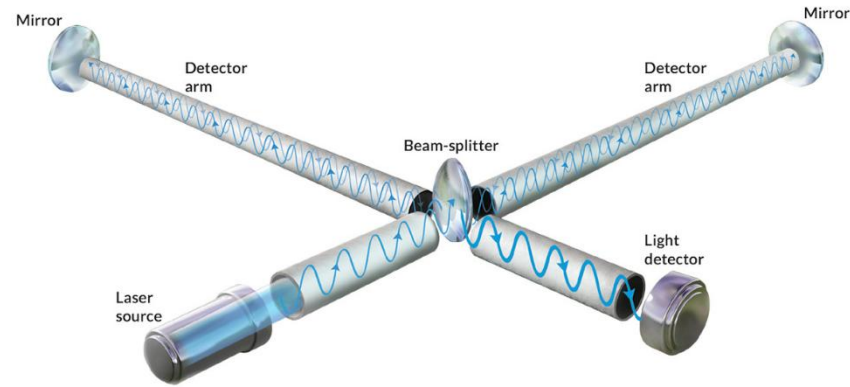

Rainer Weiss

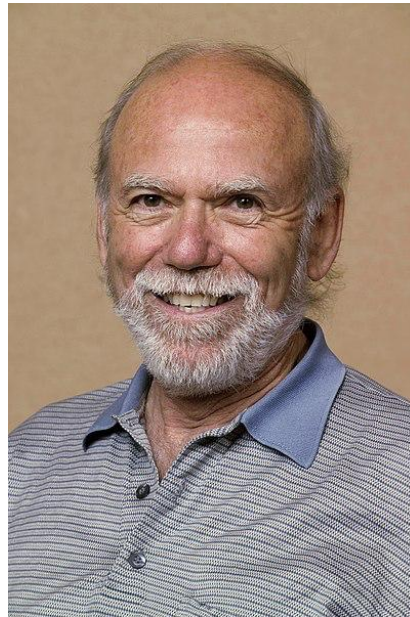

Barry Barish

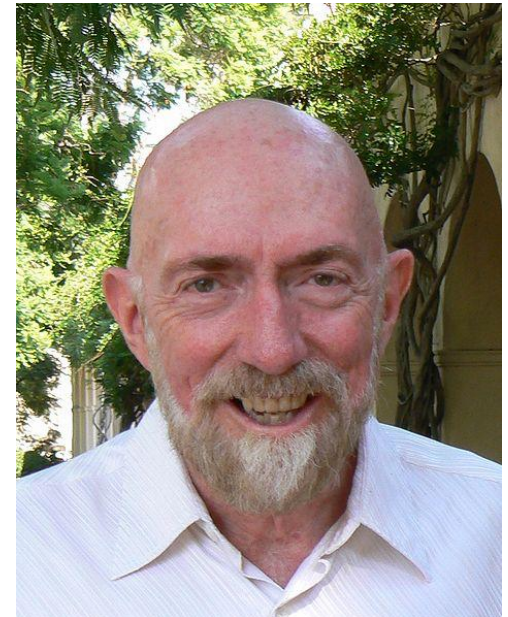

Kip Thorne

Solar neutrinos (proton-proton chain) in the Standard Solar Model

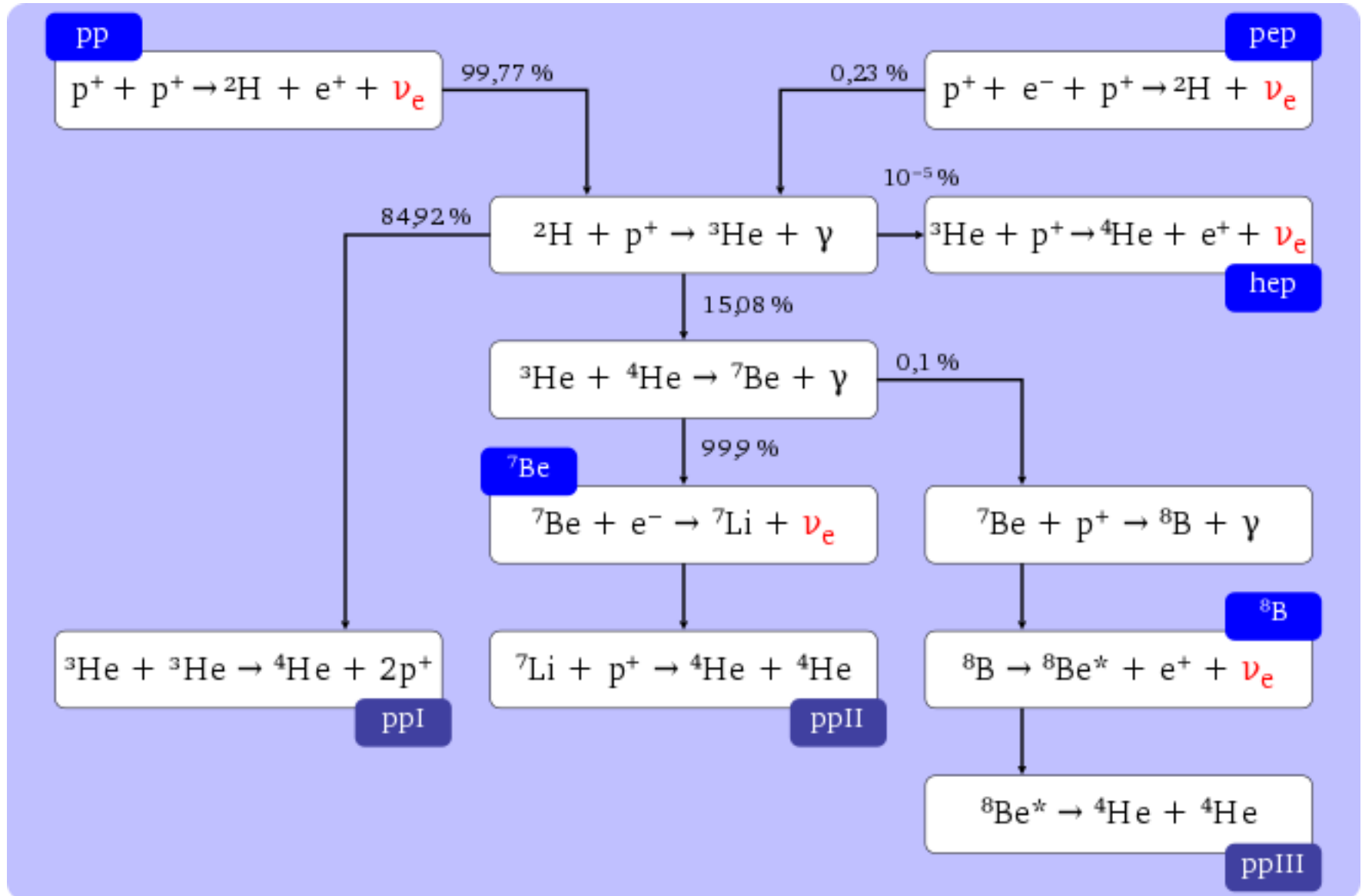

ATLAS

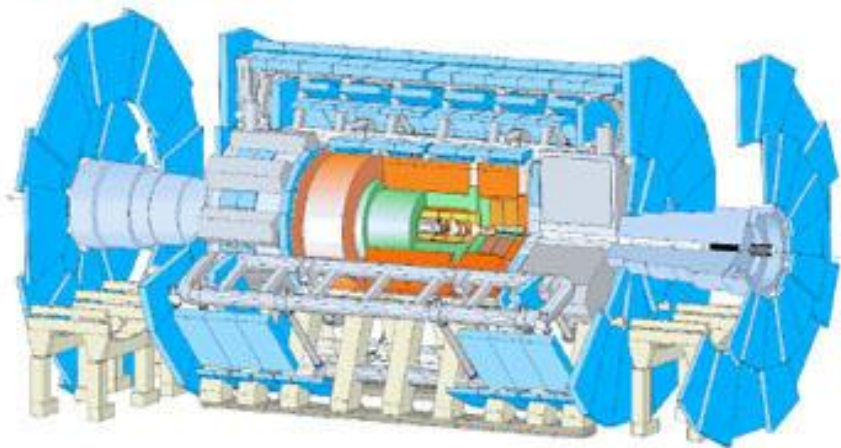

CMS

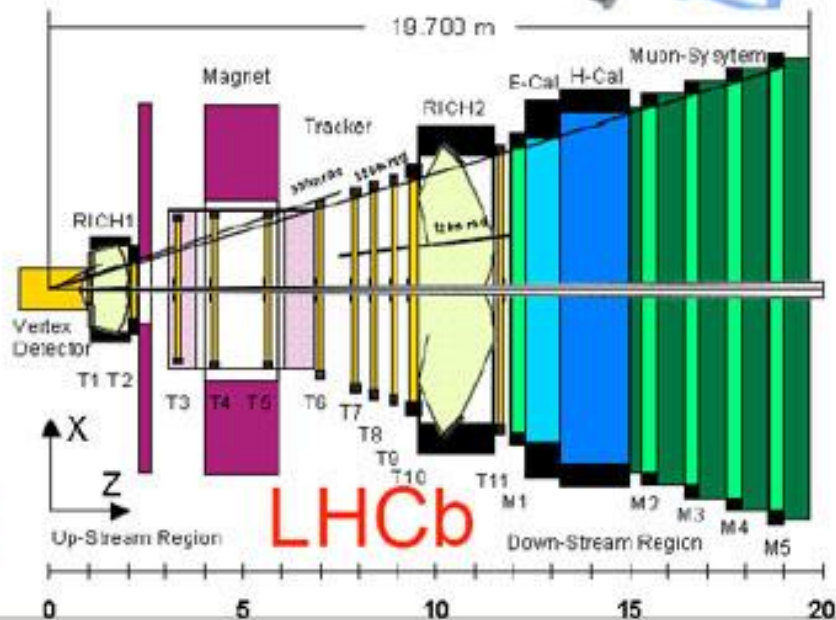
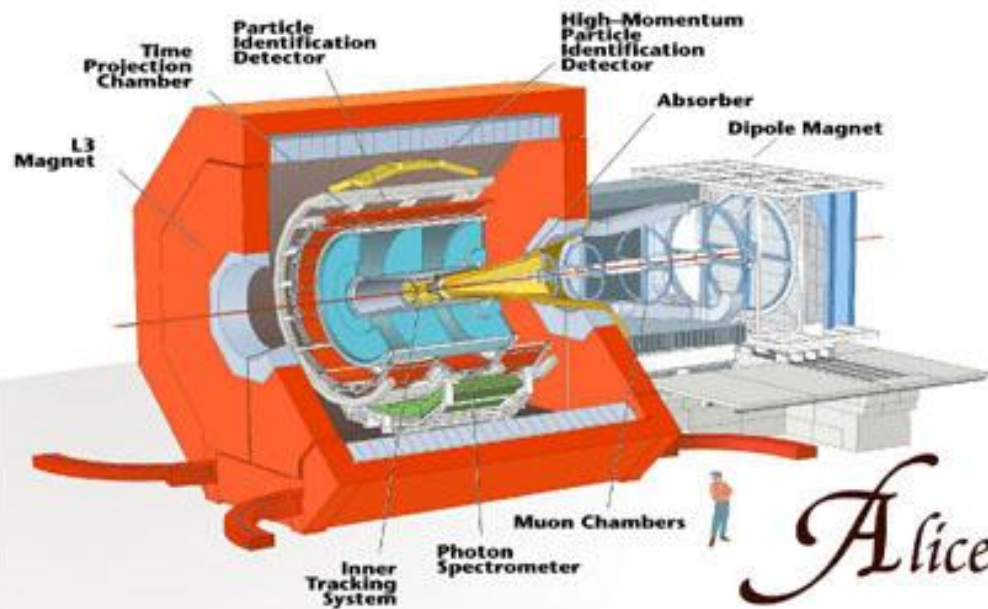

CMS

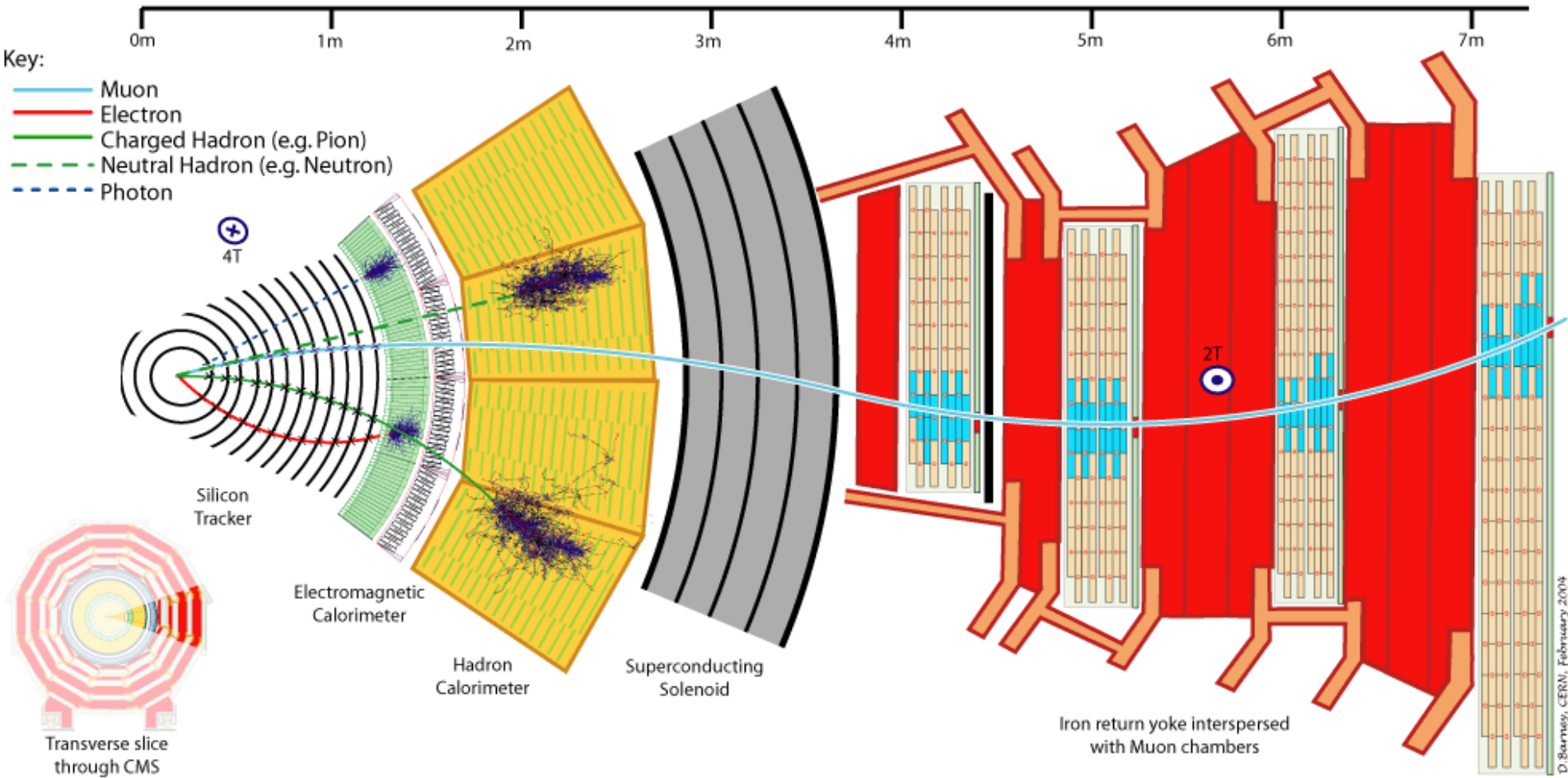

Elementary particles of the Standard Model

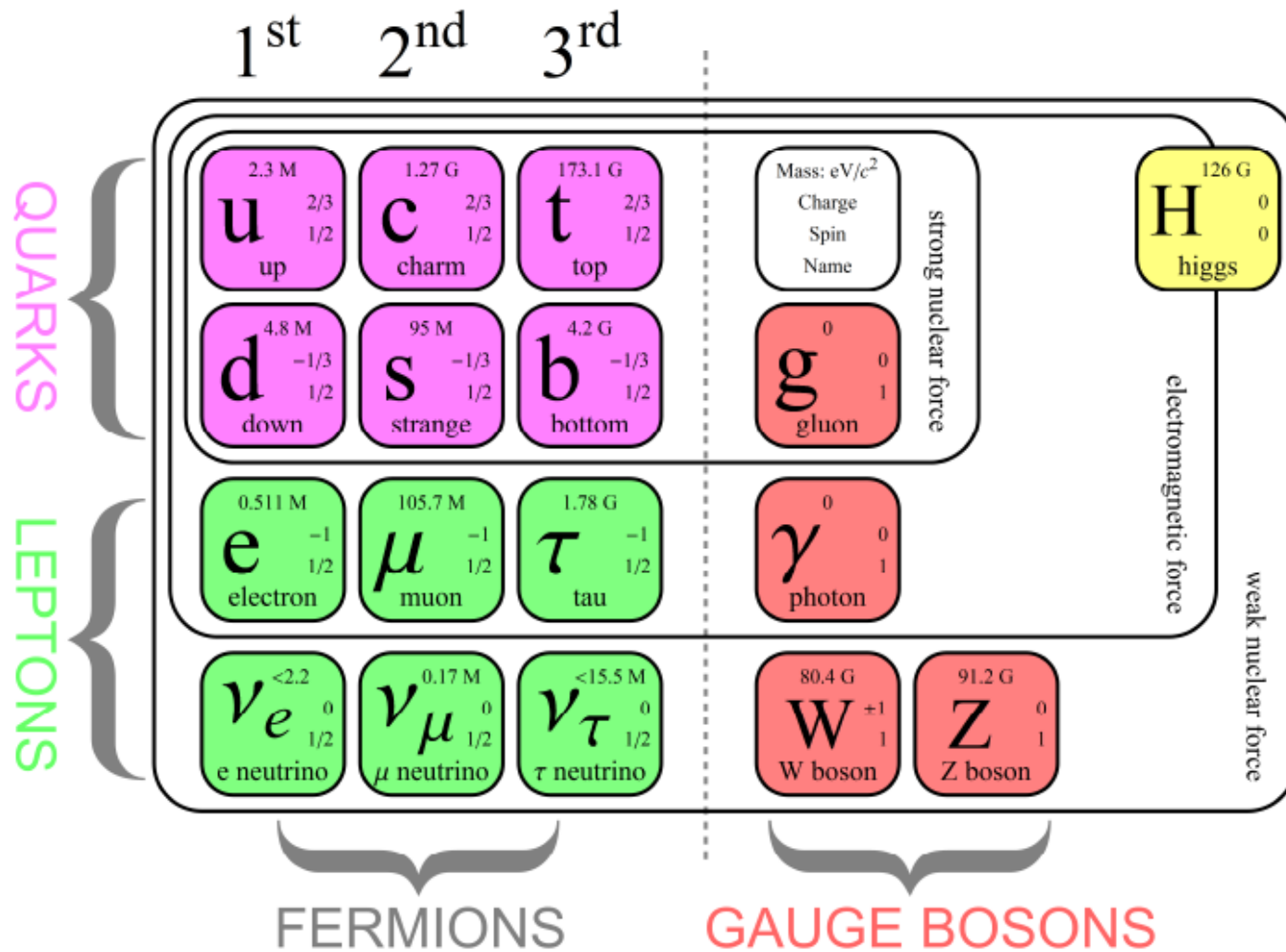

Supersymmetry

- Some physicists attempting to unify gravity with the other fundamental forces have come to a startling prediction: every fundamental particle should have a "shadow" particle as its partner.
- This relationship between matter particles and "shadow" particle is called supersymmetry.

So far, no evidence for Supersymmetry has been found. Experiments are underway at Fermilab (USA) and CERN (Europe) to look for them!

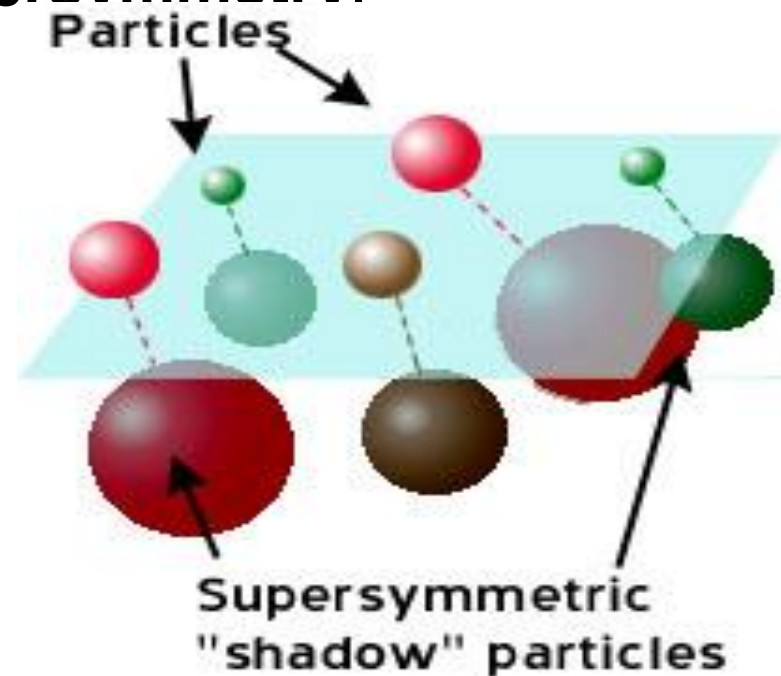

string theory

- Modern physics has good theories for quantum mechanics, relativity, and gravity. But gravity does not quite work with quantum physics. There are problems caused by our living in three spatial dimensions. **If we lived in more than three spatial dimensions, these problems would naturally resolve themselves.**
- **String Theory**, one of the recent proposals of modern physics, suggests that in a world with **4** ordinary dimensions (**3 space and 1 time**) and **7 additional very "small" dimensions**, particles are strings and membranes.
 - These extra dimensions could be very small, which is why we don't see them.

Extra Dimensions?

- Think about an **acrobat** and a **flea** on a tight rope.
 - The acrobat can move forward and backward along the rope.
 - The flea can move forward and backward as well as side to side.
 - If the flea keeps walking to one side, it goes around the rope and winds up where it started. So the acrobat has one dimension, and the flea has two dimensions, but one of these dimensions is a small closed loop.
 - So the acrobat cannot detect any more than the one dimension of the rope, just as **we can only see the world in three spatial dimensions, even though it might well have many more.**

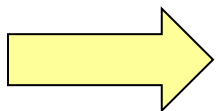

Looking for Extra Dimensions



Examples of Compactified Spatial Dimensions



M.C. Escher, Mobius Strip II (1963)

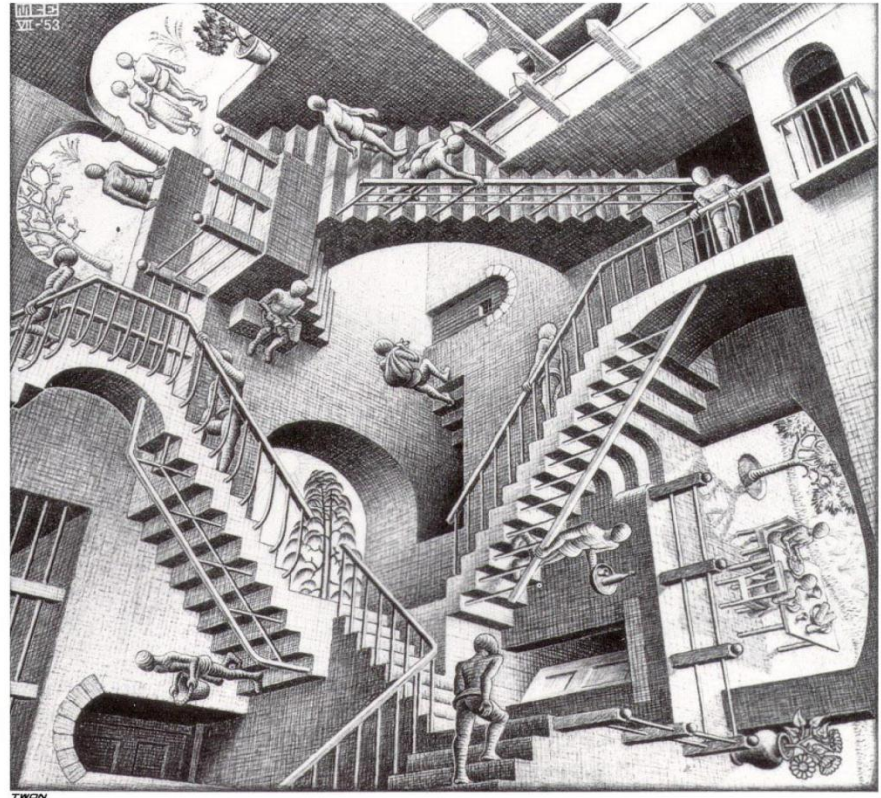

M.C. Escher, Relativity (1953)

[All M.C. Escher works and texts copyright © Cordon Art B.V., P.O. Box 101, 3740 AC The Netherlands. Used by permission.]